

# High Rise Fire Pumps CM/CGV Series, CMU/CGV Series

# Operation and Maintenance

| Form No. | Section | Issue Date | Rev. Date |
|----------|---------|------------|-----------|
| F-1031   | 2110    | 10/92      | 11/8/22   |

## Table of Contents

|  |           |
|--|-----------|
| <b>Safety Information</b> .....                      | <b>3</b>  |
| <b>Introduction</b> .....                            | <b>5</b>  |
| <b>General Description</b> .....                     | <b>5</b>  |
| Components .....                                     | 5         |
| Body Assembly .....                                  | 5         |
| Impeller Shaft Assembly .....                        | 5         |
| Options .....  | 6         |
| Electric Transfer Valve Actuator .....               | 6         |
| Flame Plated Impellers .....                         | 6         |
| Monarch Intake Valve .....                           | 6         |
| Intake Screens .....                                 | 6         |
| Anodes .....   | 6         |
| Tank to Pump Valve .....                             | 6         |
| Overheat Protection Manager (OPM) .....              | 6         |
| CM/CMU Water Flow Diagram .....                      | 9         |
| Pump Drains .....                                    | 10        |
| <b>Operating Instructions</b> .....                  | <b>11</b> |
| Transmission Operation .....                         | 11        |
| Pumping from Water Tank .....                        | 11        |
| After Pumping .....                                  | 11        |
| Pumping from Hydrant or in Relay .....               | 12        |
| After Pumping .....                                  | 12        |
| Pumping from Draft .....                             | 13        |
| After Pumping .....                                  | 14        |
| CGV Extra Pressure Stage Operation .....             | 15        |
| Fire Fighting Procedures for High-Rise Buildings ... | 15        |
| After Pumping .....                                  | 16        |
| Fire Hose Testing .....                              | 17        |
| <b>Maintenance</b> .....                             | <b>18</b> |
| Corrosion Protection .....                           | 18        |
| Optional Intake Screens .....                        | 18        |
| Optional Anodes .....                                | 18        |
| Lubrication .....                                    | 19        |
| CGV Extra Pressure Stage Bearing .....               | 19        |
| Transfer Valve Actuator .....                        | 19        |
| Packing - Braided Flexible Graphite (BFG)            |           |
| Packing Removal .....                                | 19        |
| Packing Installation .....                           | 20        |
| Packing Adjustment .....                             | 20        |
| Vacuum Testing .....                                 | 21        |
| Overheat Protection Manager (OPM) .....              | 21        |
| CGV Extra Pressure Stage Mechanical Seal .....       | 21        |
| CGV Drain and Vent System .....                      | 22        |

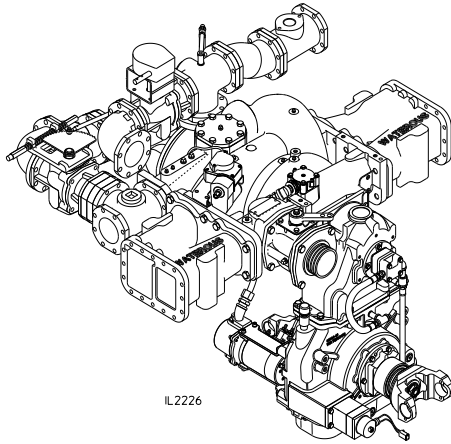

**WATEROUS**

Visit us at [www.waterousco.com](http://www.waterousco.com)



Read through the safety information and operating instructions carefully before using your Waterous Fire Pump.

Waterous Company 125 Hardman Avenue South, South St. Paul, Minnesota 55075 USA (651) 450-5000

Instructions subject to change without notice.



# Safety Information



Read through the safety information and operating instructions carefully before using your Waterous Fire Pump.

## WARNING

Death or serious personal injury might occur if proper operating procedures are not followed. The pump operator, as well as individuals connecting supply or discharge hoses to the apparatus must be familiar with these pump operating instructions as well as other operating instructions and manuals for the apparatus, water hydraulics and component limitation.

## WARNING

### **Pressure Hazard. May result in personal injury.**

Prior to connection or removal of hoses, caps or other closures with pump intake or pump discharge connections, relieve pressure by opening drains or bleeder valves. Bleeder valves should also be used while filling a hose connected to an intake with water.

## WARNING

### **Scalding Water Hazard. May result in serious burns.**

When operating the pump, be sure to open at least one discharge valve slightly to prevent the pump from overheating. If the pump runs for a few minutes completely closed, it may heat the water enough to scald someone when the valve is opened. Overheating can damage the packing, seals and other pump parts. If the apparatus builder has installed a by-pass system or other provision designed to prevent overheating, opening a discharge valve may be unnecessary.

## WARNING

### **Unexpected Truck Movement. May result in serious personal injury or death.**

Failure to properly shift transmission in accordance to the transmission operating instructions may result in unexpected truck movement which may result in serious personal injury or death.

## WARNING

### **Rotating Parts Hazard or Unexpected Truck Movement. May result in serious personal injury or death.**

Stop the engine, set parking brake and chock the wheels before going under the truck to adjust packing or to check packing gland temperature.

## WARNING

### **Packing Gland and Pump Body Temperature Hazard. May result in serious burns.**

Heat is dissipated through the cross-section of the packing, transferring the heat to the packing gland and pump body.

## WARNING

### **Hose Pressure Hazard. May cause serious personal injury.**

Use only fire hose that is rated at 700 psi or higher working pressure.

## WARNING

### **Unexpected Hose Movement Hazard. May cause serious personal injury.**

The hoses must be secured by utility rope to a substantial object to prevent unexpected movement.

# Safety Information



Read through the safety information and operating instructions carefully before using your Waterous Fire Pump.



## WARNING

### **Hose Testing Hazard. May result in serious personal injury.**

Due to a potential for catastrophic hose failure during service testing of fire hose, it is vital that safety precautions be taken to prevent exposure of anyone to this danger. Fire pumps on fire department apparatus are not designed for and should not be used for service testing of fire hoses. Hose testing machines should be used for service testing of fire hoses.



## WARNING

### **Pressure Hazard. May result in serious personal injury.**

If a fire pump on a fire department apparatus is used for service testing of fire hoses, the procedures in NFPA 1962 **MUST be followed** including the use of a fire department gate valve with a ¼-inch (6 mm) hole drilled through the gate installed between the fire apparatus discharge outlet and the hose test layout to prevent a volume surge from the pump in the event a hose bursts during testing.



## WARNING

### **Scalding Water Hazard. May result in serious burns.**

If a fire pump on a fire department apparatus is used for service testing of fire hoses, pump discharge water must be circulated through a by-pass system or discharged through a slightly open discharge valve, or some other provision must be used to prevent overheating. If the pump runs for a few minutes without adequate flow through the pump, water may be heated enough to scald someone when a valve is opened.

# Introduction

This instruction contains the information needed for operation and maintenance of CM Series centrifugal pumps. Since there are several types of transmissions available for these pumps, they are covered in separate instructions.

## General Description

The High Rise pump can operate as a CM/CMU pump only or as a CGV high pressure pump in series with the CM/CMU pump.

The High Rise pump has a CGV high pressure stage connected to the CM/CMU body end opposite the "C2X" series transmission. The two pumps share a common impeller shaft which is spline connected to the "C2X" transmission. A grease lubricated bearing in an adapter housing between the two pumps resists impeller shaft axial loads and (with the "C2X" transmission bearings) radial loads. The suction of the CGV pump is connected through an isolation valve to the left hand side outlet of the CM/CMU pump discharge manifold.

The CM/CMU pump is sealed by the normal packing stuffing boxes.

The CGV pump is sealed with a double mechanical seal. The double mechanical seal chamber provides a water pocket to cool and lubricate the seal surfaces when only the CM/CMU pump is being used.

The double mechanical seal chamber is supplied water from the CM/CMU pump first stage through a check valve only when the CM/CMU pump is being used. Some of this water goes back to the CM/CMU pump suction manifold through an orifice tube. The remainder of this water goes through orifice holes in the mechanical seal chamber into the CGV pump where it flushes the wear rings before draining out the bottom of the CGV pump.

The double mechanical seal chamber is supplied water through orifice holes in the mechanical seal chamber

when the combined High Rise pump is in operation. This water flows to the CM/CMU pump suction manifold through the orifice tube.

The vent and drain valves of the CGV pump are lever connected to the isolation valve (in the passage from the discharge to CGV suction). The vent and drain valves are open when the isolation valve is closed (CM/CMU pump operation) and closed when the isolation valve is open (CGV high pressure stage).

A control panel light turns on when the isolation valve is in an intermediate position (not full open or full closed). The light is actuated when the valve sector gear does not engage one of two normally closed switches mounted on the valve bracket.

Two rotary actuated, high pressure Waterous 3-1/2" ball valves are installed in the CGV discharge.

Two transmission oil coolers are installed in the rear upper taps of the intake fittings. The coolers consist of a copper tube coiled inside of a pipe. One end of the pipe is blocked off and contains the connections of the copper tube to the transmission hoses. The other end of the pipe is screwed into the intake fitting.

Water circulating on the outside of the coiled tube cools oil flowing on the inside of the coiled tube. Oil circulates from the discharge of the transmission oil pump, through each coiled tube cooler in series, then back to the transmission.

**OPERATION LIMITS: Do not operate pump beyond max. pressure (700 psi) or max. speed (4400 rpm). Fail to do that may result in personal injury or premature pump failure.**

## Components

### ***Body Assembly***

This assembly includes the body, cover, intake adapters, transfer and flap valves and related parts. The body, cover and adapters are either cast iron or bronze. The bronze transfer valve and its housing control water flow through the body and determine either "series" or "parallel" operation.

### ***Impeller Shaft Assembly***

This assembly consists of the bronze impellers mounted on a stainless steel shaft with wear rings, packing or mechanical seal and related parts. The impellers are balanced and the impeller shaft is supported by ball bearings.

## Options

### ***Electric Transfer Valve Actuator***

The electric transfer valve actuator permits switching the transfer valve from one position to the other by moving a switch.

### ***Flame Plated Impellers***

Approximately 75% of the pump wear due to pumping sand, occurs on the impeller hubs. For this reason, the Waterous Company adopted the policy of offering flame-plated impellers as an option (standard on CMU pumps). The flame-plating process consists of adding tungsten carbide to the surfaces to be protected from wear. This unique process produces extremely hard, well-bonded, wear-resistant coatings which consistently outwear hard chrome plating, tool steel and solid tungsten carbide.

### ***Monarch Intake Valve***

The Monarch intake valve is a package including an extra short intake fitting, an intake butterfly valve and an intake nipple with integral relief valve mounting pad, all designed to fit behind the pump panel. The Monarch intake valve also features a provision for a pre-valve relief valve and choice of manual worm gear, pneumatic or 12 or 24 volt electric actuator. For operation and maintenance instructions for the Monarch intake valve, see the following instructions:

- F-1031, Section 2318, *Operation, Maintenance and Installation Instructions for Butterfly Valves*
- F-1031, Section 2319, *Operation, Maintenance and Installation Instructions for Butterfly Valve Pneumatic Actuator*

### ***Intake Screens***

Zinc die cast screens are normally used in the intake fittings, with brass screens available optionally. The screen also acts as a sacrificial metal, which will help prevent corrosion in the rest of the pump the same way the magnesium anodes protect the metal parts of a water heater.

### ***Anodes***

As additional corrosion protection for iron body pumps, Waterous has anodes available to fit any unused 2-1/2 inch or 3 inch pipe tap in the intake fittings. Anodes provide additional surface to the water to supplement the intake screens.

### ***Tank to Pump Valve***

The tank to pump valve is a full-flow 3-1/2 inch diameter ball valve which is attached directly to the pump.

### ***Overheat Protection Manager (OPM)***

The Overheat Protection Manager (OPM) acts as a safety device by releasing hot water to the ground or back to the water tank from the discharge area of the pump.

# High Rise Pump Components

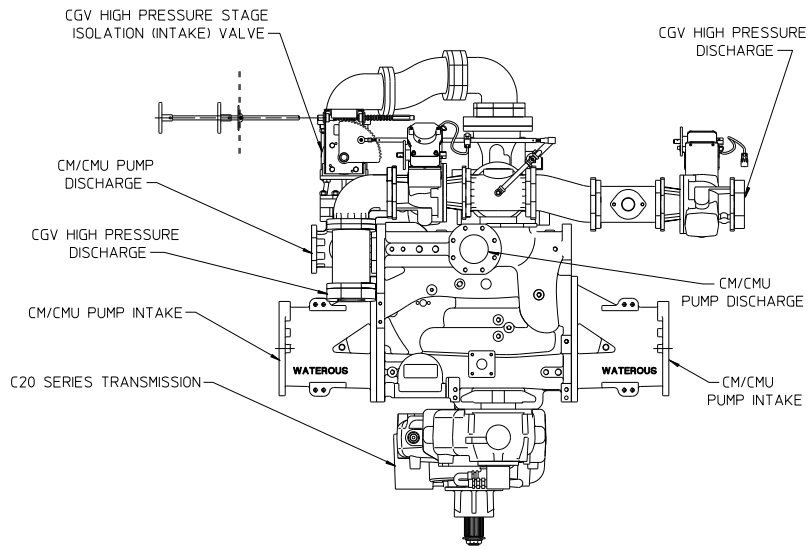
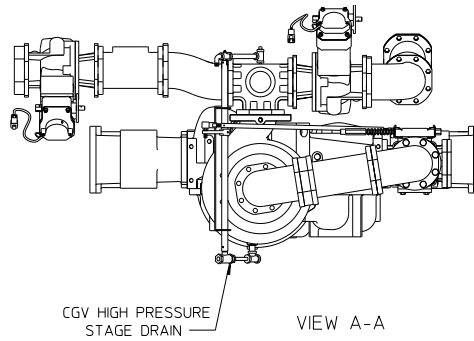

A

SIDE VIEW

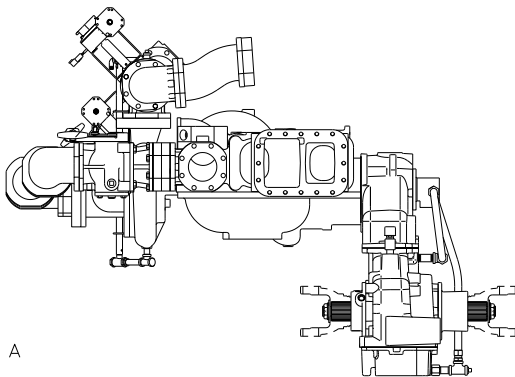

A

FRONT VIEW

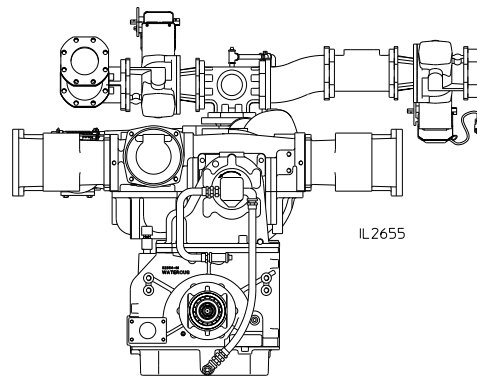

# High Rise Pump Cross-Sectional View

CGV PRESSURE STAGE

CM/CMU PUMP

TRANSMISSION

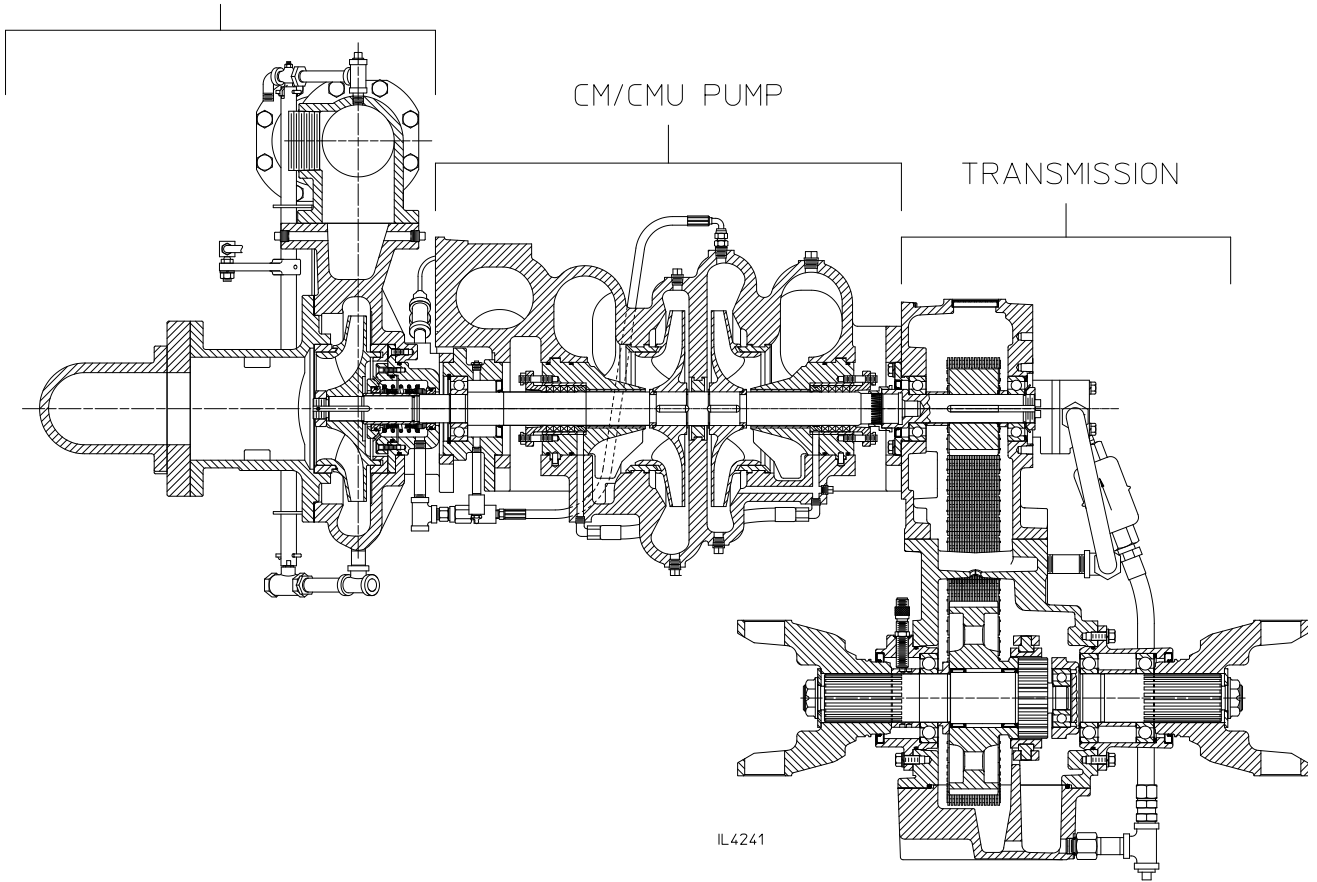

IL4241



## Parallel (Volume) Operation

Each impeller pumps half the total volume being delivered at full discharge pressure. The transfer valve routes water from first stage impeller directly to pump discharge.

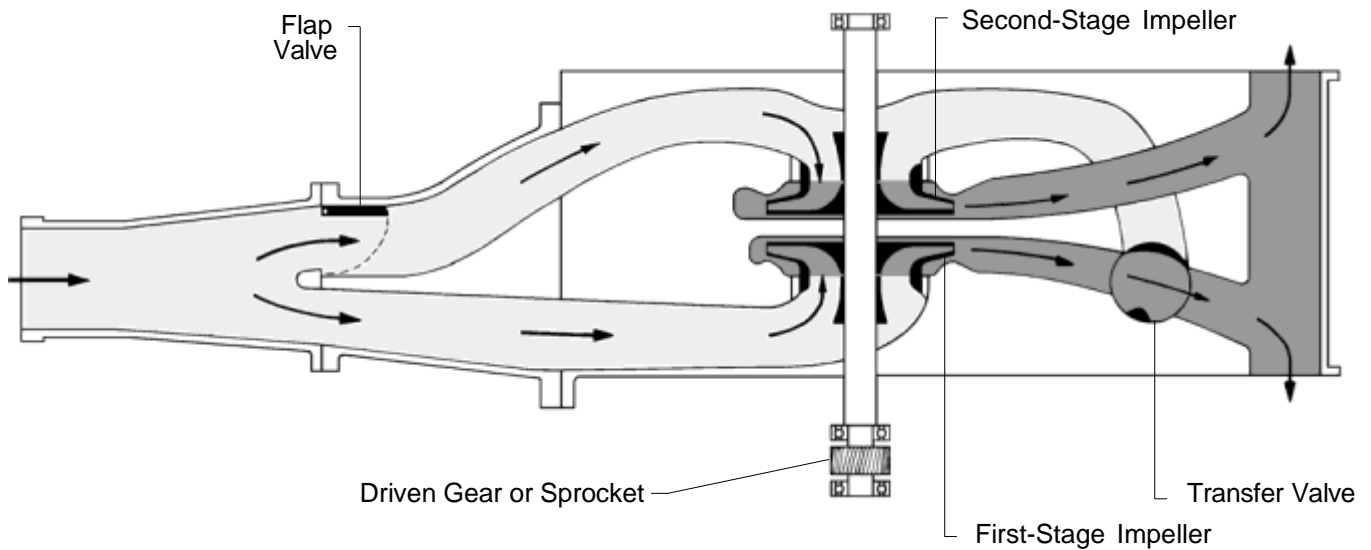

## Series (Pressure) Operation

Each impeller pumps all of the volume being delivered. Each impeller develops half of the total pump pressure. The transfer valve routes water from the first stage impeller to the second stage intake. First stage pressure also closes both flap valves. At a constant impeller speed, changing from parallel to series operation doubles the discharge pressure and cuts the volume in half.

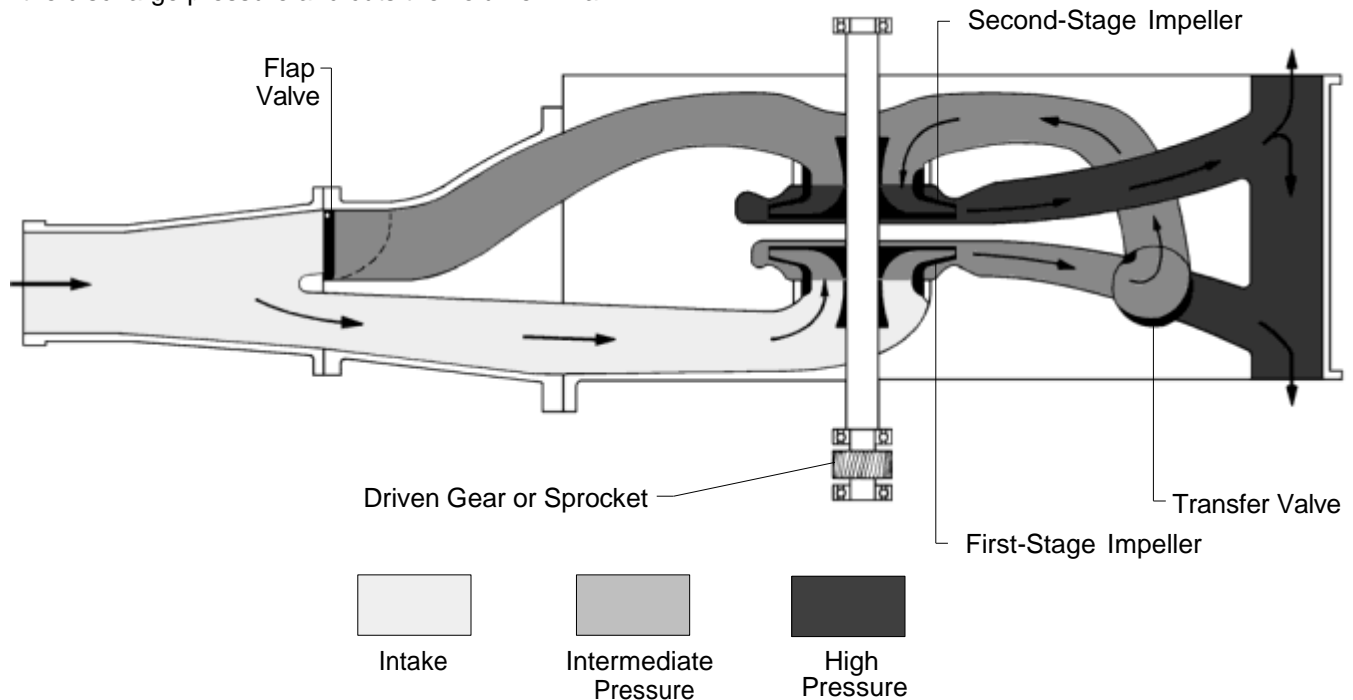

# Drain Locations

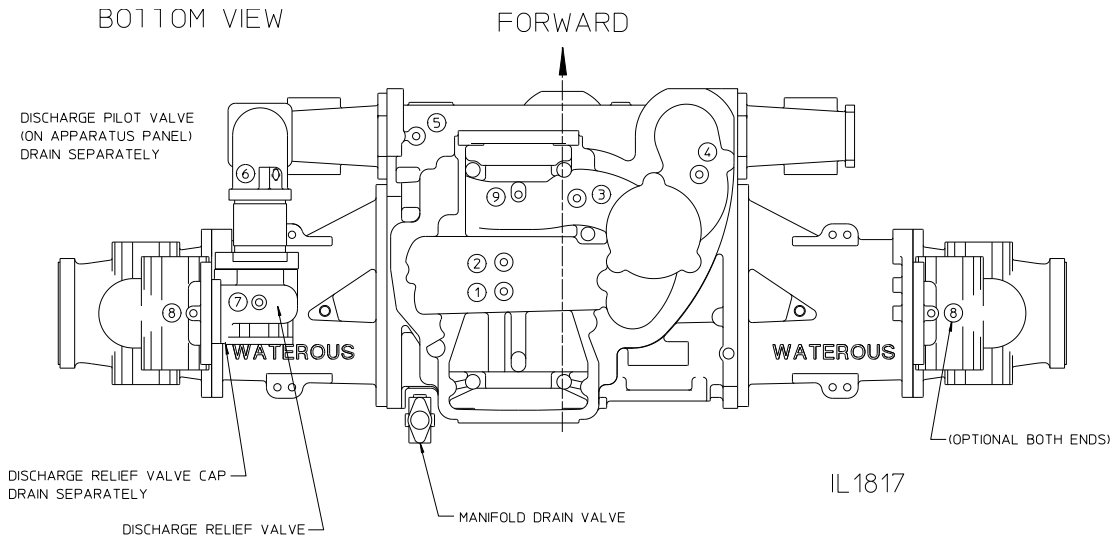

- ① 1ST STAGE VOLUTE
- ② 2ND STAGE VOLUTE
- ③ 2ND STAGE INTAKE
- ④ TRANSFER VALVE
- ⑤ MAIN DISCHARGE VALVE
- ⑥ RELIEF VALVE ELBOW OR ADAPTER
- ⑦ RELIEF VALVE BODY
- ⑧ INTAKE FITTINGS (DEPENDS ON TYPE OF INTAKE FITTING)
- ⑨ SEAL COOLING LINES

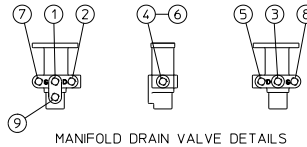

NOTE: IF THE PUMP HAS A FOAM MANIFOLD,  
IT'S DRAINS SHOULD BE PLUMBED INTO A  
SEPARATE DRAIN VALVE. DO NOT PLUMB  
INTO DRAIN VALVE USED FOR THE PUMP.

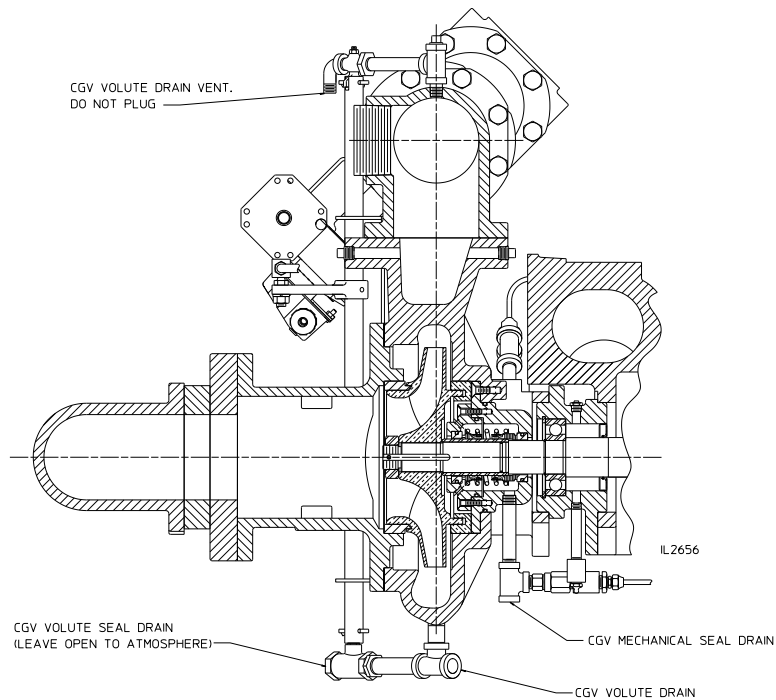

NOTE: THE CGV HIGH PRESSURE STAGE HAS IT'S OWN DRAINS WHICH ARE AUTOMATICALLY  
OPENED WHEN THE CGV STAGE IS SHUT DOWN. CONNECT CGV DRAINS (VOLUTE AND  
MECHANICAL SEAL) TO A SEPARATE DRAIN VALVE.

# Operating Instructions

## Transmission Operation

Because of the variety of transmissions available for these pumps, the methods of operating them are not explained in this section. For information on Waterous transmissions, refer to transmission operation instructions.

### Pumping from Water Tank

#### **WARNING**

##### **Pressure Hazard. May result in personal injury or death.**

Prior to connection of hoses, caps or other closures with pump intake or pump discharge connections, relieve pressure by opening drains.

#### **WARNING**

##### **Scalding Water Hazard. May result in serious burns.**

When operating the pump, be sure to open at least one discharge valve slightly to prevent the pump from overheating. If the pump runs for a few minutes completely closed, it may heat the water enough to scald someone when the valve is opened. Overheating can damage the packing, seals and other pump parts. If the apparatus builder has installed a by-pass system or other provision designed to prevent overheating, opening a discharge valve may be unnecessary.

#### **WARNING**

##### **Unexpected Truck Movement. May result in personal injury or death.**

Failure to properly shift transmission in accordance with the transmission operating instructions may result in unexpected truck movement which may result in serious personal injury or death.

- A. Engage pump in accordance with transmission instructions.
- B. Switch transfer valve to desired position.  
**NOTE: As a general rule, keep the transfer valve in PRESSURE (series) position when pumping up to 2/3 of the rated capacity of the pump and in VOLUME (parallel) when pumping more than 2/3 of the rated capacity. If the pump is operating at a high lift, or pumping a large amount of water, using the VOLUME position may be necessary to avoid cavitation.**  
If high pressure is required (more than 200 psi, 13.8 bar), operating the pump in the PRESSURE position may be necessary even if it means closing one or more valves to reduce volume and avoid cavitation. The transfer valve may be changed from one position to the other while operating the pump. Decreasing the discharge pressure will make this easier.

If the pump has a manually operated transfer valve, slow engine speed to reduce the discharge pressure to 75 psi (5.2 bar) or less. With the electric transfer valve, reducing the discharge pressure is necessary only if it exceeds 250 psi (17.3 bar).

- C. Open valve(s) in piping between water tank and pump intake and at least one discharge valve.
- D. Allow about 30 seconds for water to flow into pump.  
**NOTE: Priming the pump may be necessary because of air trapped in piping.**
- E. Accelerate engine to obtain desired discharge pressure and capacity.
- F. Set relief valves or other pressure governing device to desired pressure.

**NOTE: For extra pressure stage pumping instructions, see page 11.**

### After Pumping

#### **WARNING**

##### **Pressure Hazard. May result in personal injury or death.**

Prior to removal of hoses, caps or other closures with pump intake or pump discharge connections, relieve pressure by opening drains.

- A. Disengage pump drive in accordance with transmission instructions.
- B. If pumping anything but clean water, remove all intake and discharge caps, open all valves and open all drains. Flush entire system with clean, fresh water for several minutes to remove all traces of impurities.
- C. If pump is kept full of water when not in use, make sure water is clean and non-corrosive. Make sure the pump is completely full or completely drained - never partially full.

#### **NOTICE**

If the pump is exposed to freezing temperatures, drain all water from pump, lines and accessories.

- D. Close all drains and install intake and discharge caps.

## Pumping from Hydrant or in Relay

### WARNING

#### **Pressure Hazard. May result in personal injury or death.**

Prior to connection of hoses, caps or other closures with pump intake or pump discharge connections, relieve pressure by opening drains or bleeder valves.

### WARNING

#### **Scalding Water Hazard. May result in serious burns.**

When operating the pump, be sure to open at least one discharge valve slightly to prevent the pump from overheating. If the pump runs even for a few minutes completely closed it may heat the water enough to scald someone when the valve is opened. Overheating can damage the packing, seals and other pump parts. If the apparatus builder has installed a by-pass system or other provision designed to prevent overheating, opening a discharge valve may be unnecessary.

### WARNING

#### **Unexpected Truck Movement. May result in personal injury or death.**

Failure to properly shift transmission in accordance with the transmission operating instructions may result in unexpected truck movement which may result in serious personal injury or death.

- A. Engage pump in accordance with transmission instructions.
- B. Open intake, hydrant and other valves as necessary to allow water to enter the pump.

**NOTE: Bleeder valves should be used while filling a hose connected to an intake with water.**

- C. Switch transfer valve to desired position.  
**NOTE: As a general rule, keep the transfer valve in PRESSURE (series) position when pumping up to 2/3 of the rated capacity of the pump, and in VOLUME (parallel) when pumping more than 2/3 of the rated capacity. If high pressure is required (more than 200 psi, 13.8 bar), operating the pump in the PRESSURE position may be necessary even if it means closing one or more valves to reduce volume and avoid cavitation.**
- D. Open discharge valves and accelerate engine to obtain desired discharge pressure and capacity.
- E. Set relief valves or other pressure governing device to desired pressure.

**NOTE: Do not attempt to pump more water than is available from the hydrant or relaying pumper. Always make sure the intake pressure compound-gage reading stays above zero.**

**Some fire departments operate at a minimum intake pressure of 10 psi (.7 bar) when pumping from hydrant or in relay to prevent a "soft" intake hose from collapsing.**

**NOTE: For extra pressure stage pumping instructions, see page 11.**

### *After Pumping*

### WARNING

#### **Pressure Hazard. May result in personal injury or death.**

Prior to removal of hoses, caps or other closures with pump intake or pump discharge connections, relieve pressure by opening drains or bleeder valves.

- A. Disengage pump drive in accordance with transmission instructions.
- B. If pumping anything but clean water, remove all intake and discharge caps, open all valves and open all drains. Flush entire system with clean, fresh water for several minutes to remove all traces of impurities.
- C. If pump is kept full of water when not in use, make sure water is clean and non-corrosive. Make sure the pump is completely full or completely drained - never partially full.

### *Notice*

If the pump is exposed to freezing temperatures, drain all water from pump, lines and accessories.

- D. Close all drains and install intake and discharge caps.
- E. Switch transfer valve back and forth once.

## Pumping from Draft

### WARNING

#### **Pressure Hazard. May result in personal injury or death.**

Prior to connection of hoses, caps or other closures with pump intake or pump discharge connections, relieve pressure by opening drains.

### WARNING

#### **Scalding Water Hazard. May result in serious burns.**

When operating the pump, be sure to open at least one discharge valve slightly to prevent the pump from overheating. If the pump runs even for a few minutes completely closed it may heat the water enough to scald someone when the valve is opened. Overheating can damage the packing, seals and other pump parts. If the apparatus builder has installed a by-pass system or other provision designed to prevent overheating, opening a discharge valve may be unnecessary.

### WARNING

#### **Unexpected Truck Movement. May result in personal injury or death.**

Failure to properly shift transmission in accordance with the transmission operating instructions may result in unexpected truck movement which may result in serious personal injury or death.

To get full capacity, quick prime and maintain pump efficiency:

- A. Position vehicle as near as possible to water supply.
- B. Avoid humps and sharp bends in intake hose. Make sure no part of hose is higher than pump intake inlet. (Air pockets in intake hose may cause loss of prime or erratic pump action, and may reduce pump capacity.)
- C. Make sure all intake connections are tight and discharge valves are closed.
- D. Immerse intake strainer at least two feet below water surface to prevent pump from drawing air. (Whirlpools forming above intake strainer indicate that the strainer is too close to the surface of the water.)
- E. Make sure intake strainer is far enough from the bottom to prevent sand, gravel and other foreign matter from being drawn into the pump.
- F. Engage pump in accordance with transmission instructions.
- G. Switch transfer valve to desired position.

**NOTE:** As a general rule, keep the transfer valve in **PRESSURE (series)** position when pumping up to 2/3 of the rated capacity of the pump, and in **VOLUME (parallel)** when pumping more than 2/3 rated capacity. If the pump is operating at a high lift, or pumping a large amount of water, using the **VOLUME** position may be necessary to avoid cavitation.

The transfer valve may be changed from one position to the other while operating the pump. Decreasing the discharge pressure will make this easier. If the pump has a manually operated transfer valve, slow engine speed to reduce the discharge pressure to 75 psi (5.2 bar) or less. With electric transfer valves, reducing the discharge pressure is necessary only if it exceeds 250 psi (17.3 bar).

**If high pressure is required (more than 200 psi, 13.8 bar), operating the pump in the PRESSURE position may be necessary even if it means closing one or more valves to reduce volume and avoid cavitation.**

#### **Prime the pump.**

Priming before pumping in the CM pump only condition requires the following procedure to prevent an air inflow through the CGV pump mechanical seal chamber.

- a. Set the parking brake or block the apparatus wheels.
- b. Engage the pump drive.
- c. Attach suction and discharge hoses.
- d. Close all pump discharge valve.
- e. Open isolation valve (to close vent and drain valves on a CGV pump thus preventing an influx of air into the CM body through the mechanical seal orifice tube).
- f. Place the CM transfer valve into volume or pressure mode.
- g. Prime the CM pump until the priming pump flows water for 15 seconds.
- h. Bring the discharge pressure to 25 psi with the transfer valve in the volume mode and 50 psi if the transfer valve is in pressure mode. Note: Operate the priming pump as required to maintain the prime.
- i. Close the isolation valve
- j. Open the discharge valves and bring the pump to the desired pressure.
- k. Set relief valves or other pressure governing device to desired pressure.

**NOTE: For extra pressure stage pumping instructions, see page 15.**

## After Pumping

### **WARNING**

#### **Pressure Hazard. May result in personal injury or death.**

Prior to removal of hoses, caps or other closures with pump intake or pump discharge connections, relieve pressure by opening drains.

- A. Disengage pump drive in accordance with transmission instructions.
- B. If pumping anything but clean water, remove all intake and discharge caps, open all valves and open all drains. Flush entire system with clean, fresh water for several minutes to remove all traces of impurities.
- C. If pump is kept full of water when not in use, make sure water is clean and non-corrosive. Make sure the pump is completely full or completely drained - never partially full.

If the pump is exposed to freezing temperatures, drain all water from pump, lines and accessories.

- D. Close all drains and install intake and discharge caps.
- E. Switch transfer valve back and forth once.

## CGV Pressure Stage Operation

### WARNING

#### **Pressure Hazard.** **May result in personal injury or death.**

Prior to connection of hoses, caps or other closures with pump intake or pump discharge connections, relieve pressure by opening drains.

### WARNING

#### **Scalding Water Hazard.** **May result in serious burns.**

When operating the pump, be sure to open at least one discharge valve slightly to prevent the extra pressure stage from overheating. If the extra pressure stage runs even for a few seconds completely closed it may heat the water enough to scald someone when the valve is opened. Overheating can damage the packing, seals and other pump parts. If the apparatus builder has installed a bypass system or other provision designed to prevent overheating, opening a discharge valve may be unnecessary.

### WARNING

#### **Hose Pressure Hazard.** **May cause serious personal injury.**

Use only fire hose that is rated at 700 psi or higher working pressure.

### WARNING

#### **Unexpected Hose Movement Hazard.** **May cause serious personal injury.**

The hoses must be secured by utility rope to a substantial object to prevent unexpected movement.

### NOTICE

There must be a continuous discharge (at least 20 GPM) from one CGV high pressure stage outlet at all times when in the high pressure configuration. The high pressure CGV stage would be in a shutoff condition without this flow.

Shut down pump or reduce engine speed to idle when changing between operating configurations.

The operating configuration is controlled by the isolation valve. The isolation valve must be fully closed when operating as a CM/CMU pump only. The isolation valve must be fully open when operating in the high pressure mode

### NOTICE

The isolation valve must be fully open or closed, never in an intermediate position.

### WARNING

#### **Unexpected Truck Movement.** **May result in personal injury or death.**

Failure to properly shift transmission in accordance with the transmission operating instructions may result in unexpected truck movement which may result in serious personal injury or death.

- A. Set parking brake (do not set parking brake if it is located between the engine and pump transmission) and block the fire truck wheels.
- B. Attach suction and discharge hoses.
- C. Engage pump drive.
- D. Close all pump discharge valves.
- E. Place isolation valve in closed position
- F. Place CM/CMU transfer valve in desired (volume or pressure) position.
- G. Operate electrical primer to fill CM/CMU pump with water (let a steady stream of water flow out of the priming pump for 3 seconds).
- H. Open CM/CMU pump discharge valves and accelerate engine to obtain desired pressure and capacity.
- I. To operate pump in high pressure configuration, reduce engine speed to idle, open the CGV control valve to the full open position, then open high pressure discharges.

### **Fire Fighting Procedures for High-Rise Buildings Using Hi-Rise Pumps**

These fire fighting procedures adapted with permission from *FDNY Procedure DCN: 3.02.01* dated January 1, 1997, are recommended for high pressure operation of the CM/CGV.

### Hydraulics



#### **Supplying High-Rise Standpipe System Using Fire Department Pumpers**

*Classification of Pumpers:*

- A. Conventional pumpers: Two-stage 1000 GPM or 2000 GPM pumpers.
- B. High-Pressure pumper: A pumper with a third stage capability. The third stage can supply 500 GPM at 700 psi.

*To Insure Adequate Water Supply to the Standpipe System:*

- A. Supply the system with at least two pumpers.
- B. Supply at least two separate Siamese's.
- C. If only one Siamese is available, supply the first flow hose outlet with the second line.
- D. When a High-Pressure pumper is going to activate the 3rd stage, only one 3" special high-pressure hose supply line may be stretched into a Siamese connection.
- E. To ensure that water is being supplied to the standpipe system:
  1. When the pumper is equipped with flow meters, use a discharge gate to which a flow meter is connected.
  2. If the pumper is not equipped with flow meters, it must be monitored to prevent churning and overheating of the water in the pump.



- 3. Pump operators supplying the standpipe system must coordinate their pumping pressure.

- F. If the building is equipped with a combination standpipe/sprinkler system (yellow Siamese caps), augmentation is required.

 **Pump Pressures**

To simplify computing pump pressure when supplying a standpipe system, a chart has been formulated. These calculations are based on nozzle pressure, friction loss of three lengths of 2-1/2" hose, head loss, system friction loss and friction loss of two lengths of 3-1/2" hose supplying the Siamese.

| Recommended Pump Pressures |                    |            |
|----------------------------|--------------------|------------|
| Fire Floor(s)              | Controlling Nozzle | Fog Nozzle |
| 1-10                       | 150 psi            | 200 psi    |
| 11-20                      | 200 psi            | 250 psi    |
| 21-30                      | 250 psi            | 300 psi    |
| 31-40                      | 300 psi            | 350 psi    |
| 41-50                      | 350 psi            | 400 psi    |
| 51-60                      | 400 psi            | 450 psi    |
| 61-70                      | 450 psi            | 500 psi    |
| 71-80                      | 500 psi            | 550 psi    |
| 81-90                      | 550 psi            | 600 psi    |
| 91-100                     | 600 psi            | 650 psi    |
| 101-110                    | 650 psi            | 700 psi    |

If the height of the fire floor requires pressure in excess of 250 psi the officer in charge can order higher pressures at the pumper if the following precautions are followed:

- A. All civilian and Fire Department personnel are removed from a zone 50 feet on each side of the hose line supplying the Siamese. 3" special high-pressure hose must be used.
- B. Warning tapes, stanchions or utility ropes are utilized to maintain this area clear.
- C. An Officer-In-Charge is designated to control this pumping operation.
- D. An audible alert be used to inform civilians and personnel on the scene. (Public address systems on apparatus may be utilized.
- E. Supply line to the Siamese or standpipe outlet valve must be secured by utility rope to a substantial object.
- F. Only special high-pressure fittings may be used. They are painted white and are noticeably heavier than standard fittings.
- G. Maintain safety zones of at least 50' around a working pumper (high-pressure) in all directions.
- H. Supply lines must be connected to the pumper on the side opposite the control panel.
- I. Unused gated inlets and outlets must be closed and all caps secured to the pumper.
- J. Each pumper being utilized at pressures in excess of 250 psi must be controlled by the ECC assisted by an ECC from a non-operating pumper. (One person to operate pumper and one person to maintain radio communications.
- K. Command post to establish radio communications with all units involved in high-pressure pumping operation.
- L. During high-pressure pumping, members must not utilize stairways as staging or rest areas. Utilize minimum amount of personnel in stairways served by standpipes.
- M. If the standpipe system is equipped with handlines, they should be replaced with fire department hose before being used due to the unknown age and condition of the existing hose.

- N. The Officer-In-Charge must designate a unit(s), to control and mark off safety zones.

When the fire is above the 50th floor, or the building water supply is unsatisfactory, it may be necessary to use the third stage of the high-pressure pumper. Only the Officer-In-Charge of the fire may order this use. Pump operators of high-pressure pumps must ensure that tether security ropes are in place prior to activating the third (3rd) stage of the pump.

**Operating Procedures:**

- A. Pump pressure must be increased slowly and floor outlet valves opened slowly to avoid pressure surges at the nozzle.
- B. Member operating floor outlet valve must open it sufficiently to provide the required nozzle pressure as determined by the officer supervising the line.

**After Pumping**

Place control valve in closed position to drain pump. (The vent on the CGV discharge opens when the control valve is closed). Open mechanical seal drain valve and CGV volute drain valve in addition to the CM/CMU pump manifold drain valve.

 **WARNING**

**Pressure Hazard. May result in personal injury or death.**

Prior to removal of hoses, caps or other closures with pump intake or pump discharge connections, relieve pressure by opening drains.

**NOTICE**

If the pump is exposed to freezing temperatures, drain all water from pump, lines and accessories.



# Fire Hose Testing



## WARNING

### **Hose Testing Hazard. May result in serious personal injury.**

Due to a potential for catastrophic hose failure during service testing of fire hose, it is vital that safety precautions be taken to prevent exposure of anyone to this danger. Fire pumps on fire department apparatus are not designed for and should not be used for service testing of fire hoses. Hose testing machines should be used for service testing of fire hoses.

NFPA 1962 *Standard for the Inspection, Care, and use of Fire Hose, Couplings, and Nozzles and the Service Testing of Fire Hose* provides requirements and testing procedures for service-testing fire hose at least annually. NFPA 1962 includes procedures for service testing with either a hose testing machine or with a pump on a fire department fire apparatus.



## WARNING

### **Pressure Hazard. May result in serious personal injury.**

If a fire pump on a fire department apparatus is used for service testing of fire hoses, the procedures in NFPA 1962 **MUST be followed** including the use of a fire department gate valve with a ¼-inch (6 mm) hole drilled through the gate installed between the fire apparatus discharge outlet and the hose test layout to prevent a volume surge from the pump in the event a hose bursts during testing.

During fire hose testing with a fire pump on a fire department fire apparatus, the fire pump is required to be operated at high discharge pressure with little or no flow out of the apparatus.



## WARNING

### **Scalding Water Hazard. May result in serious burns.**

If a fire pump on a fire department apparatus is used for service testing of fire hoses, pump discharge water must be circulated through a by-pass system or discharged through a slightly open discharge valve, or some other provision must be used to prevent overheating. If the pump runs for a few minutes without adequate flow through the pump, water may be heated enough to scald someone when a valve is opened.

## NOTICE

If a fire pump on a fire department apparatus is used for service testing of fire hoses, operating the pump at high discharge pressure with little or no flow may result in severe damage to the pump.

# Maintenance

## Corrosion Protection

### Optional Intake Screens

Once per month check to make sure the intake screens are not clogged or damaged. Also check for corrosion, and replace screens if damage is severe. For the screen to adequately control corrosion, there must be a strong electrical contact between the screen and the fitting. Remove any corrosion, debris or paint from the counter bore that will insulate the screen from the intake fitting. If the screen does not fit tightly, adjust the gap of the slot on the outside diameter of the screen to ensure a tight fit.

**NOTE:** These screens are die-cast which results in a slight taper from one side to the other. Install the screen with the thinner cross-section facing out to minimize flow restriction.

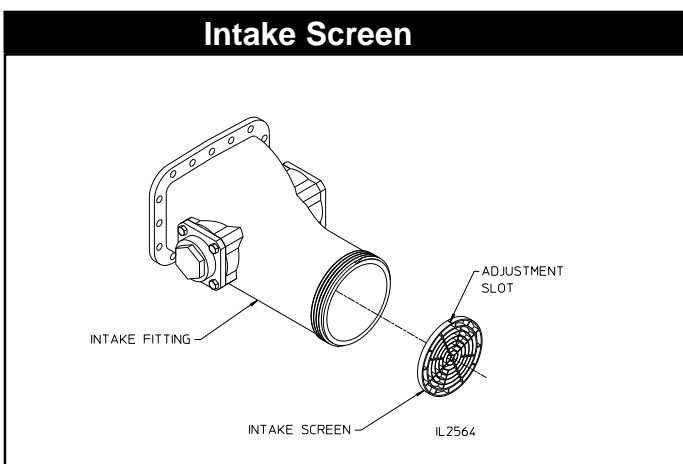

### Optional Anodes

Twice per year, remove the anodes and check for erosion of the replaceable elements. Replace the elements if more than half of either of the elements has eroded. Anodes are normally mounted on the pump intake piping, but they may also be installed in the discharge piping if no intake mounting locations were available. To determine if an anode is installed, check the intake and discharge piping looking for a large hex (2- 1/2 in. across flats). Physical mounting of the anode may be via an NPT tap or bolt-on flange as described below.

**NOTE:** The replaceable elements must make contact with water to be effective. Do not paint or use any other coating on the replaceable elements.

#### Bolt-on Anodes

Unscrew the 2- 1/2 in. hex from the pump. If elements require replacement, unscrew the hex head cap screw.

**NOTE:** The screw was installed using thread sealant so higher force than normal may be necessary to remove.

Replace one or both elements as necessary. Install the hex head screw using Loctite 271 (red) on the screw threads. Apply thread sealant to threads and screw the 2- 1/2 in. hex into the pipe tap until tight.

### Threaded Anodes

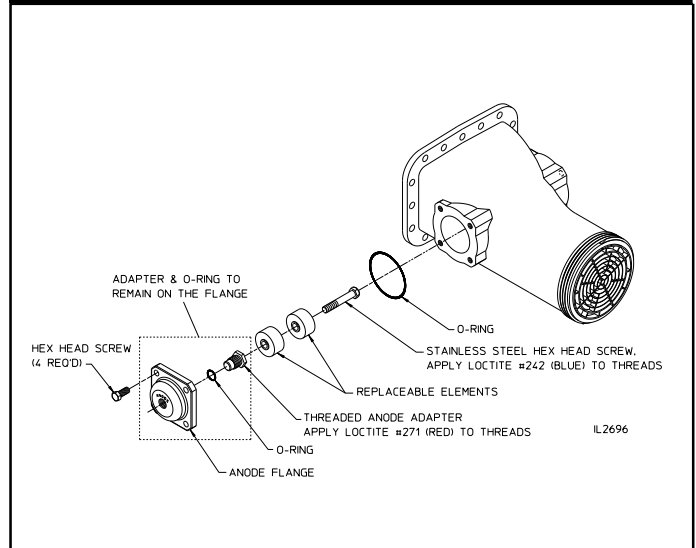

### Threaded Anodes

**NOTE:** The 2- 1/2 in. hex is threaded into a bushing that should remain on the pump. Be sure to restrain the bushing when removing the 2- 1/2 in. hex.

Unscrew the 2- 1/2 in. hex from the pump. If the elements require replacement, unscrew the hex head cap screw.

**NOTE:** The screw was installed using thread sealant so higher force than normal may be necessary to remove.

Replace one or both elements as necessary. Install the hex head screw using Loctite 271 (red) on the screw threads. Remove any paint or corrosion from the face around the NPT tap on the pump. Apply thread sealant to the threads and screw the 2- 1/2 in. hex into the pipe tap until tight.

### Threaded Anodes

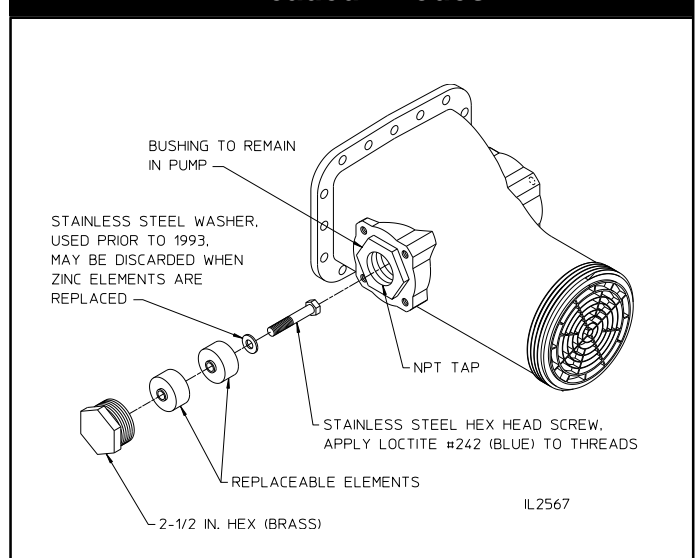

## Lubrication

### CGV High Pressure Stage Bearing

The impeller shaft is supported at the extra pressure stage by a ball bearing. A fitting permits lubrication of this bearing.

Add a good quality, medium consistency, ball bearing grease until it comes out of the relief groove of the lubrication fitting. Add grease after every 100 hours of pump

operation, or every six months, whichever comes first. (See CGV Mechanical Seal figure on page 16 for location of lube fitting).

### Transfer Valve Actuator

The transfer valve actuator requires no lubrication.

## Packing - Braided Flexible Graphite (BFG)

Waterous uses a braided graphite fiber, with reinforced flexible graphite yarns and high purity graphite filament yarns that appear on the corners as well as throughout the body of the packing. The graphite reinforcement allows the flexible graphite yarns to provide greater tensile strength.

This type of packing reduces the frictional heat created between the shaft and the I.D. of the packing. By dissipating the heat through the cross section of the packing, the heat is transferred to the packing gland and the seal housing.

### WARNING

**Packing Gland and Pump Body Temperature Hazard. May result in serious burns.**

Heat is dissipated through the cross-section of the packing, transferring the heat to the packing gland and pump body.

### Packing Removal

### WARNING

**Truck movement hazard. May cause serious personal injury.**

Stop engine, set the parking brake and chock the wheels before going under truck to remove packing.

- Remove the unbalanced nuts, flat washers and packing gland halves from one end of the pump.
- Engage the pump per appropriate operating instructions. Operate the pump in VOLUME position. Gradually increase the discharge pressure until the packing is forced out of the stuffing box. Pressure in excess of 300 psi (20.7 bar) may be required.

### WARNING

**Pump overheating hazard. May cause damage to the pump.**

Circulate enough water through the pump to prevent overheating. Do not pressurize the pump over 600 psi.

- If all the packing is not forced out, it may be necessary to remove the remaining packing by hand, using a pick or similar device. Waterous has a packing removal tool (P/N 5782) available for this purpose (shown below).
- Replace packing per instructions on page 15, repeating the procedure for the opposite end of the pump.

### Packing Removal Tool

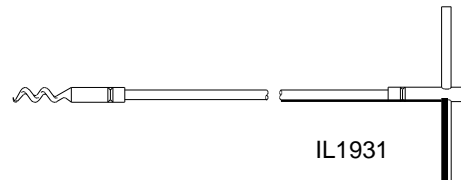

## Packing Installation

- A. Before installing the new packing, be sure that all of the old packing is removed from the seal housing.
- B. Be sure that the seal housing and the shaft are clean and free of any packing residue.
- C. Lightly lubricate the packing ring I.D. and O.D. with mineral oil, automotive grease or engine oil for installation purposes.
- D. Make sure packing is clean.
- E. Carefully install one ring of packing. With the aid of packing glands, push the packing into the seal housing as far as possible. Repeat this operation with each ring, staggering the joints at least 90° apart. Install the packing rings until the top of the last ring is about 1/4 inch from the end of the seal housing (at least 1/8 inch is required for the packing gland nose entrance into the stuffing box), see figure below.

**NOTE: Be sure that the packing joints are staggered at least 90° apart.**

- F. Install packing glands, nuts and washers. Tighten gland nuts one flat beyond finger tight, see Figure 11.

**NOTE: The milled slot on the nut should face the gland.**

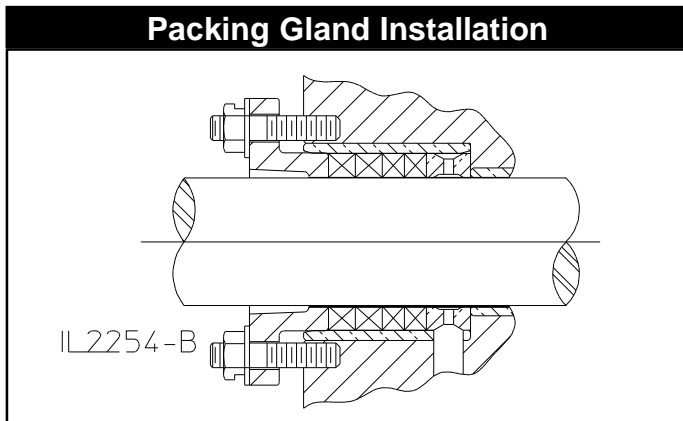

- G. Adjust packing as required per instructions on the next page.

## Packing Adjustment

The pump packing is designed and adjusted to drip slightly during operation. This is to cool and lubricate the packing. It is desirable to adjust the stuffing box to maintain a leakage rate of 10 to 120 drops per minute when operating at a discharge pressure of 150 psi (10.3 bar). Operate pump in the VOLUME position.

Leakage through the braided flexible graphite (BFG) packing may be at zero or diminish to zero leakage and may not respond to loosening of the packing nuts to restore leakage, see Adjustment Step 3. While the packing gland and stuffing box and pump body may reach high temperatures during this time, the impeller shaft will be protected from heat damage.

### NOTICE

**Pump overheating hazard.  
May cause damage to the pump.**

Circulate enough water through the pump to prevent overheating.

### WARNING

**Truck movement hazard.  
May cause serious personal injury.**

Stop engine, set the parking brake and chock the wheels before going under truck to adjust packing.

- A. Engage pump per appropriate operating instructions. Operate the pump in VOLUME position at the capacity pressure shown on the serial plate for ten (10) minutes.

### NOTICE

**Observe the stuffing box drip rate from the side of the truck.**

- B. Observe leakage. Normal leakage is 10-120 drops per minute.
- C. If drip rate is considered high, stop the engine and tighten the packing gland nuts 1/2 to 1 flat (maximum of 1/6 of a revolution). Make appropriate adjustments starting with 1 flat, when approaching the final adjustment reduce to 1/2 flat. This reduces the possibility of over tightening. **Tighten the gland nuts equally to ensure that the packing gland goes on straight.** Gradually reducing leakage during the first hour of operation will result in a better seal over a longer period of time. Adjust the drip rate on one stuffing box until the appropriate rate is obtained, then proceed to the other end of the pump.

### NOTICE

**Stopping the leakage entirely at this point will cause the packing to overheat.**

- D. Operate the pump at the capacity pressure shown on the serial plate for two (2) minutes to let packing run in, then observe the drip rate.

### WARNING

**Packing Gland and Pump Body Temperature Hazard. May result in serious burns.**

Heat is dissipated through the cross-section of the packing, transferring the heat to the packing gland and pump body.

- E. Repeat steps 3 and 4 until the drop rate is acceptable.

**Note: After adjusting the packing, the pump must pass the following vacuum test described on the next page.**

## Vacuum Test

- A. Remove all caps except openings without valves. Close all discharge, intake and drain valves and other similar openings. Operate priming device to create a vacuum of about 22 in. Hg/.735 atmosphere in pump, then stop primer and engine.
- B. Watch the pressure gauge; if vacuum drops more than 10 in. Hg/.334 atmospheres in five (5) minutes, listen for air leaks around the packing gland, gaskets, valves, etc.
- C. Replace gaskets, re-adjust packing, repack or otherwise repair source of trouble.
- D. Repeat test.

## Overheat Protection Manager (OPM)

Check the electrical circuit by pressing the test button located on the panel plate every 100 hours of pump operation or every six months, whichever comes first.

## CGV High Pressure Stage Mechanical Seal

The CGV mechanical seals should not require maintenance as long as they are not subjected to unusual operating conditions.

The following (done at six (6) month intervals) will ensure long seal life:

- A. Hydrostatically pressurize the pump to 60-200 psig using a hydrant or other external water source. There should not be any visible leakage.
- B. Remove high pressure supply line and fitting and clean out if necessary. Flush seal chamber by connecting the pump to a hydrant or other pressurized water source.

### CGV Mechanical Seal

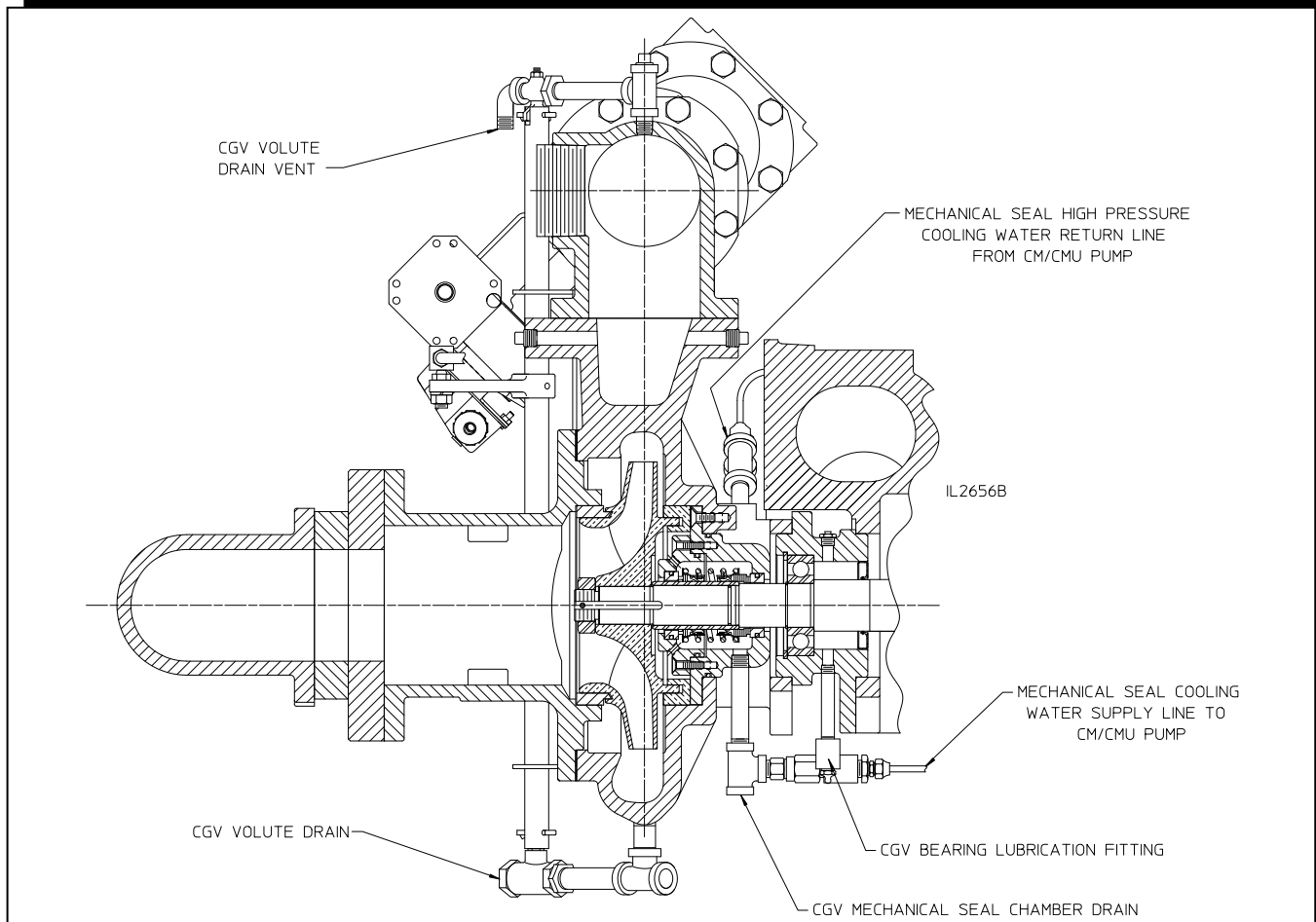

Every six (6) months check operation of CGV control valve. Open and close valve and check vent and drain valves.

## CGV Vent and Drain System

