

Panel Mounted Drain Valve

Operation and Maintenance

Form No.	Section	Issue Date	Rev. Date
F-1031	2305.1	05/95	04/05/06

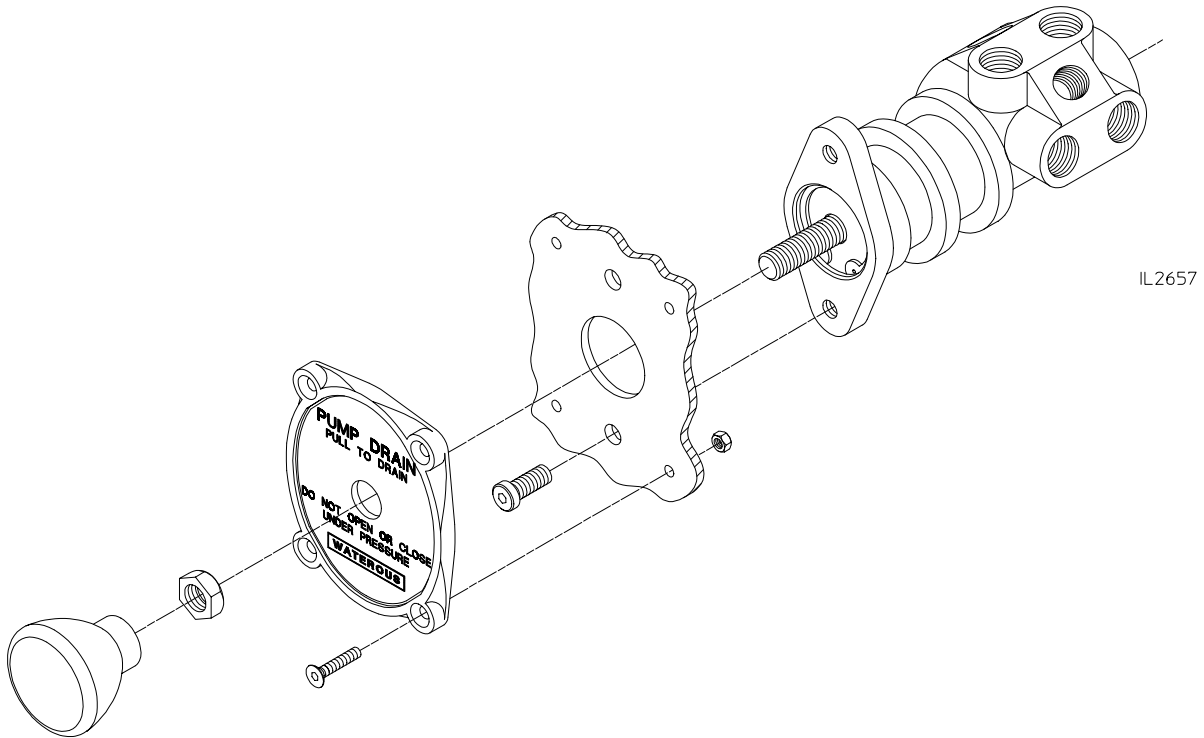

Table of Contents

General Description	1
Operating Instructions	1
Maintenance	1

Illustrations

Figures:	
1. Panel Mounted Drain Valve Assembly	1



Read through the safety information and operating instructions carefully before using your Waterous Fire Pump.

WATEROUS

Fire Pumps – Since 1886

Visit us at www.waterousco.com

Introduction

This instruction contains the information needed for operation and maintenance of the Panel Mounted Drain Valve.

General Description

The Waterous Panel Mounted Drain Valve provides a convenient means of draining a fire pump and related equipment after each operation; its design permits simultaneous draining of at least eight lines. The Panel Mounted Drain Valve consists of a stainless steel sliding plunger in bronze body. Quad and O-rings prevent leakage between the two parts.

Figure 1. Panel Mounted Drain Valve Assembly

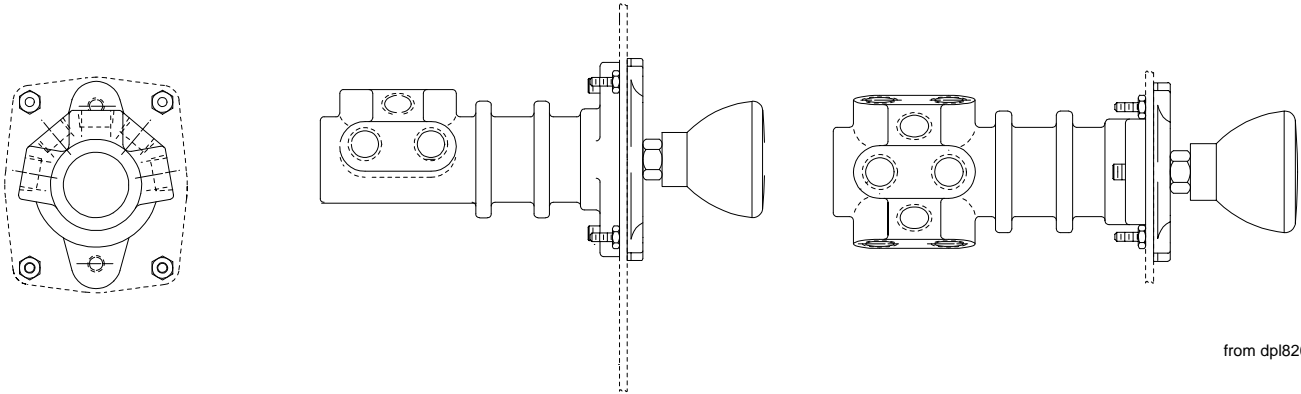

Operating Instructions

CAUTION

Do not open or close drain valve when pump is under pressure or vacuum. Water or air passing by the O-ring at high velocity may pull it out of its groove and damage it.

CAUTION

Make sure drain is completely closed before operating main pump. If valve is partially open, priming will not only be difficult, but water pressure may damage plunger rings.

To Open Valve

After each operation, pull control knob out as far as it will go.

To Close Valve

Before each operation, press control knob in as far as it will go and tap sharply with palm of hand to seat plunger.

Maintenance

If the manifold drain valve should begin to leak, replace the quad ring and O-ring in the following manner:

1. **ASSEMBLY 60898** – Remove round head screws and pull assembled plunger and instruction plate forward out of panel. Remove quad ring and O-ring from plunger.

ASSEMBLY 61756 or 61756-1 – Loosen hex nut and remove knob and nut. Remove screws and pull off instruction plate. Remove retaining ring and carefully pull out assembled plunger, stem and spring housing. Be careful not to lose spring and ball which may pop out as spring housing clears valve body.

Note: If the center valve mounting hole is smaller than 1-1/8 inch, remove control knob and disconnect drain lines before disassembling valve.

2. Examine plunger and bore of body for nicks or scratches caused by sand or dirt in the water being pumped. With an emery cloth, carefully remove any raised metal near abrasions. If damage is severe, replace plunger or body.
3. Coat new quad ring and new O-ring with grease and install on plunger. Make sure rings are seated properly and not twisted.
4. **ASSEMBLY 60898** – Carefully insert plunger in flanged end of body. Be sure not to damage rings when installing plunger. Align screw holes in instruction plate and body, and install two round head screws.

ASSEMBLY 61756 or 61756-1 – Carefully insert plunger in flanged end of body. Be sure not to damage rings when installing plunger.