

Operation and Maintenance

Intake Relief Valve

Form No.	Section	Issue Date	Rev. Date
F-1031	2314	08/20/96	09/08/11

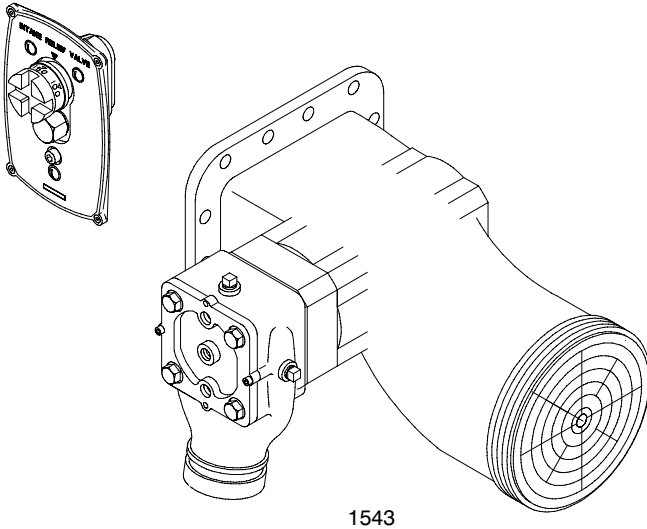

Table of Contents

Safety Information	1
Introduction	2
Operating Instructions	5
After Pumping	5
Maintenance Instructions	6

Illustrations

Figures:

1. Pressure Control System 2
2. Intake Relief Valve Operation Showing Pump Intake Pressure Below Pilot Valve Setting 3
3. Intake Relief Valve Operation Showing Pump Intake Pressure Above Pilot Valve Setting 4
4. Relief Valve Panel Plate and Calibration Dial 5
5. Relief Valve Outlet Warning Plate 5
6. Pilot Valve Maintenance 6



Read through the safety information and operating instructions carefully before using your Waterous Fire Pump.



Visit us at www.waterousco.com

Safety Information



Read through the safety information and operating instructions carefully before using your Waterous Intake Relief Valve.

WARNING

Death or serious personal injury might occur if proper operating procedures are not followed. The pump operator, as well as individuals connecting supply or discharge hoses to the apparatus must be familiar with these pump operating instructions as well as other operating instructions and manuals for the apparatus, water hydraulics and component limitation.

WARNING

Do not cap the outlet of the relief valve. This system is designed to hold vacuum while priming and operating from draft.

DANGER

Intake Pressure Relief Outlet Hazard. Will result in serious injury or death.

Do not cap the intake pressure relief outlet.

A hose is connected to this outlet must be secure to prevent violent movement of the hose during pump operation. Position the hose to aim away apparatus and people.

Introduction

Figure 1. Pressure Control System

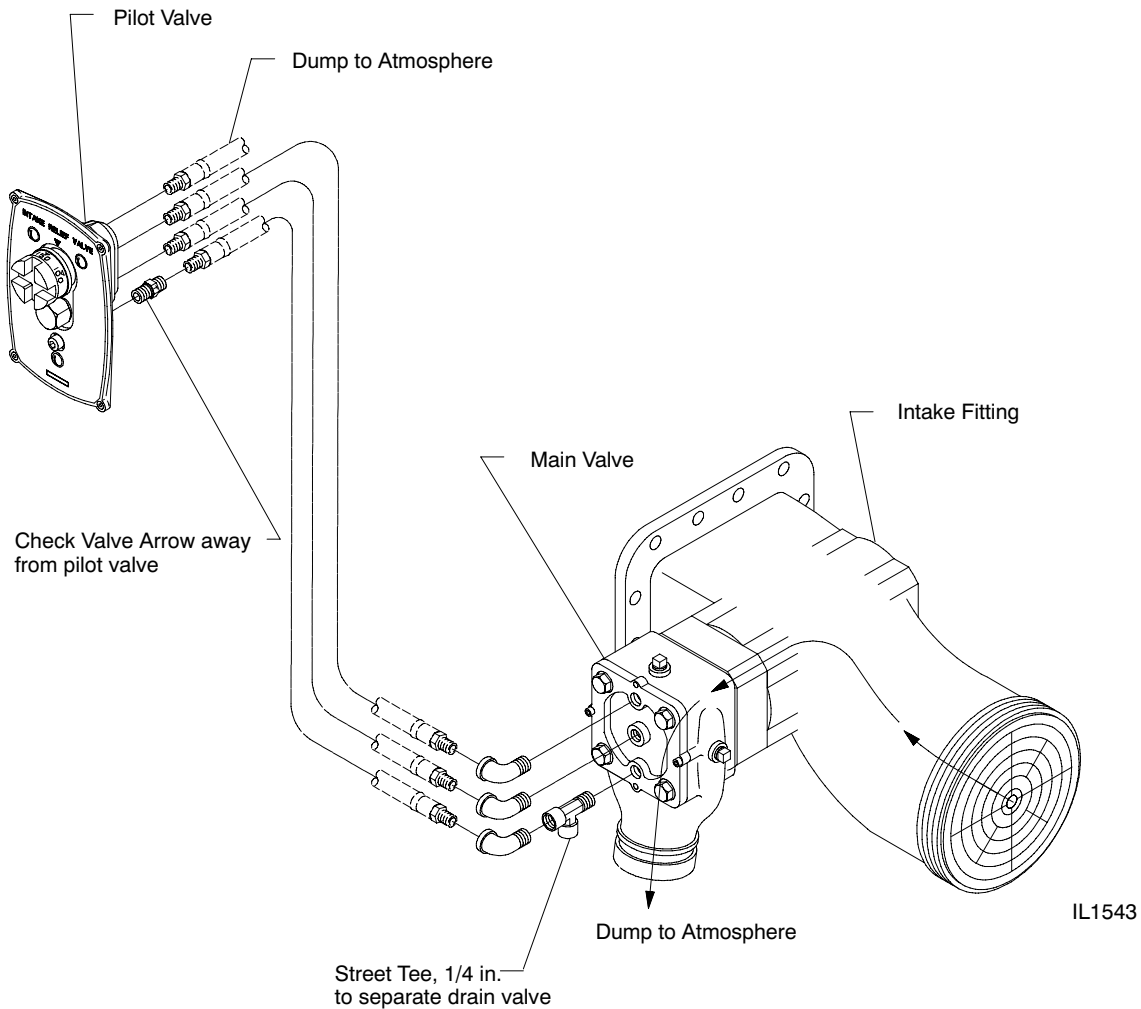

The Waterous Intake Relief Valve system is designed to act as a safety valve by “dumping” excess pressure from the inlet side of the pump. This makes it less likely that “water hammer” will burst the supply line, and allows the discharge relief valve or governor system to properly control discharge pressure.

The Waterous Intake Relief Valve system incorporates two separate units for flexibility in installation and operation: the pilot valve and the main valve. The pilot valve controls operation of the main valve and can be panel mounted to be easily field adjusted for varying operating conditions (between 50 and 250 psi), or compartment mounted and preset for a specific pressure. It includes a removable strainer and removable needle valve for easy servicing.

Figure 2. Intake Relief Valve Operation Showing Pump Intake Pressure Below Pilot Valve Setting

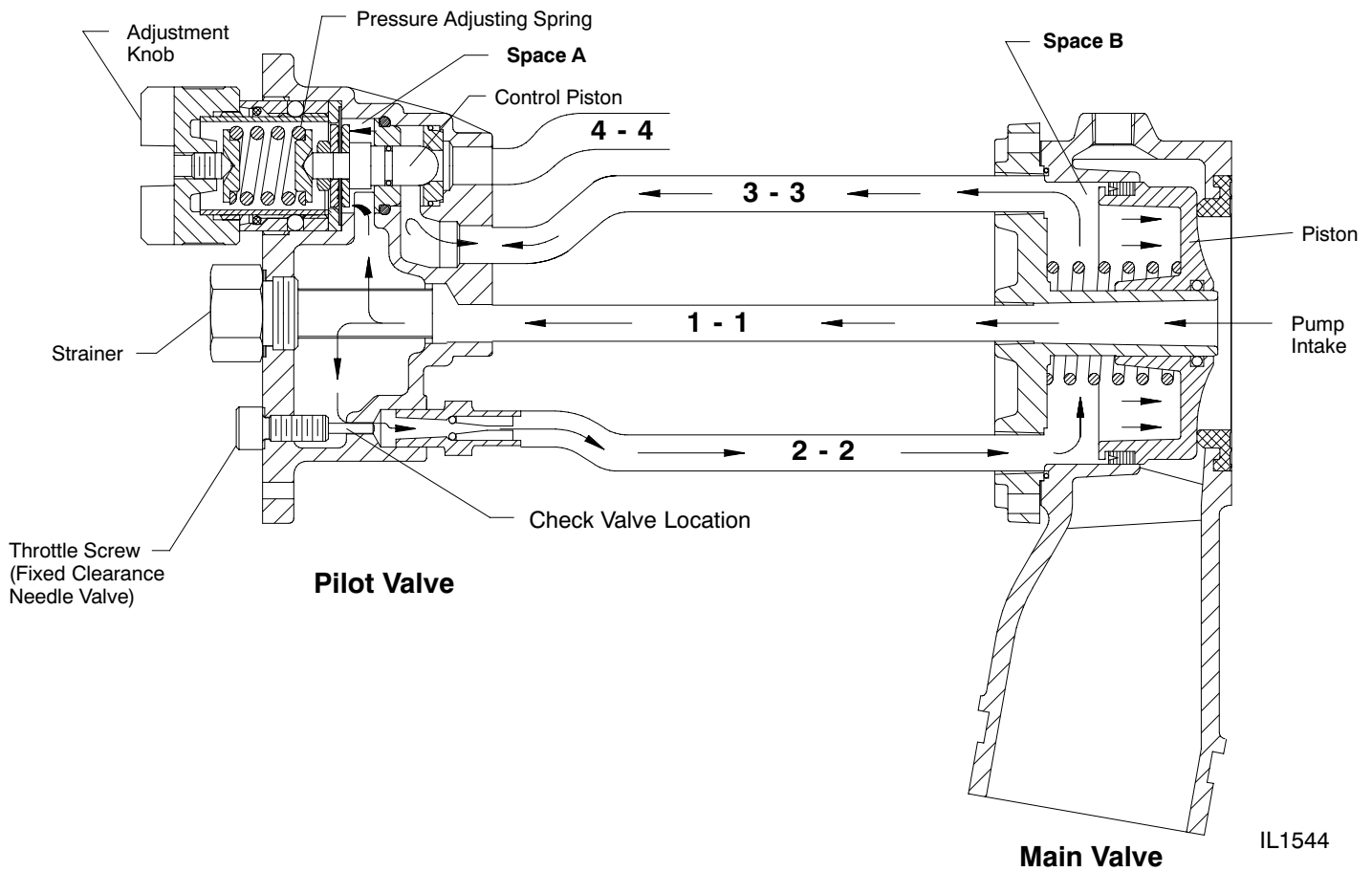

The preset value is set from 50-250 psi by adjusting the pressure control knob. Turning the control knob changes the load on the pressure adjusting spring which pushes the control piston onto its seat. The water pressure in the pipe system acts through line 1-1 and through the strainer up to space A, between diaphragm and the control bushing. Space B, behind the piston of the main valve, is controlled under pressure by the throttle screw and line 2-2. This pressure then continues via line 3-3 to the seat of the control valve.

If the intake pressure is below the preset value, the pressure adjusting spring will hold the control piston against its seat, equalizing the pressure on both sides of the main valve piston. Because the surface area is larger on the back side of the main valve piston the force applied is also greater, and together with the force of the spring, holds the main valve closed.

Figure 3. Intake Relief Valve Operation Showing Pump Intake Pressure Above Pilot Valve Setting

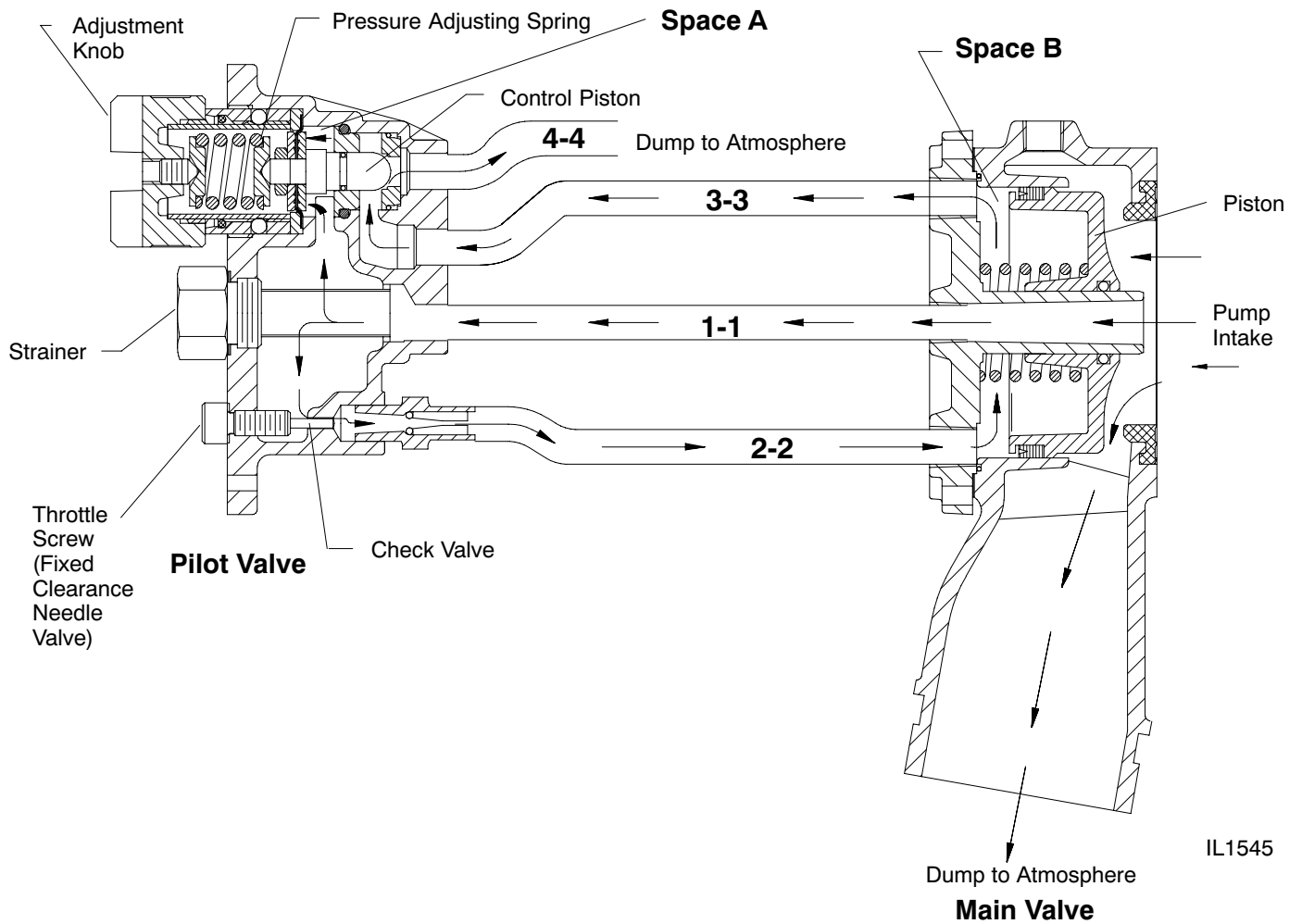

If the water pressure rises above the preset value, the pressure acting on the diaphragm will overcome the force of the spring. At that point the control piston lifts off its seat and the control valve is open. With the control valve open, the water can escape via line 3-3 from the pressure space B behind the piston of the main valve, into line 4-4 and then to the atmosphere.

Since the amount of water which can enter space B from the piping system is limited by the throttle screw, the control valve opening results in a pressure drop in space B. When the pressure in space B drops, the main valve piston is lifted off its seat by the higher line pressure and the main valve is opened.

Operating Instructions

Set operating pressure by aligning the desired setting on the calibration dial with the arrow on the top of the panel plate. A spanner wrench may be used to move the calibration dial.

WARNING

Do not cap the outlet of the relief valve. This system is designed to hold vacuum while priming and operating from draft.

DANGER

Intake Pressure Relief Outlet Hazard. Will result in serious injury or death.

Do not cap the intake pressure relief outlet.

A hose is connected to this outlet must be secure to prevent violent movement of the hose during pump operation. Position the hose to aim away apparatus and people.

A warning plate must be located near intake relief valve outlet.

NOTE: The pilot valve “dump” will discharge water when intake pressure exceeds the set pressure.

Figure 4. Relief Valve Panel Plate and Calibration Dial

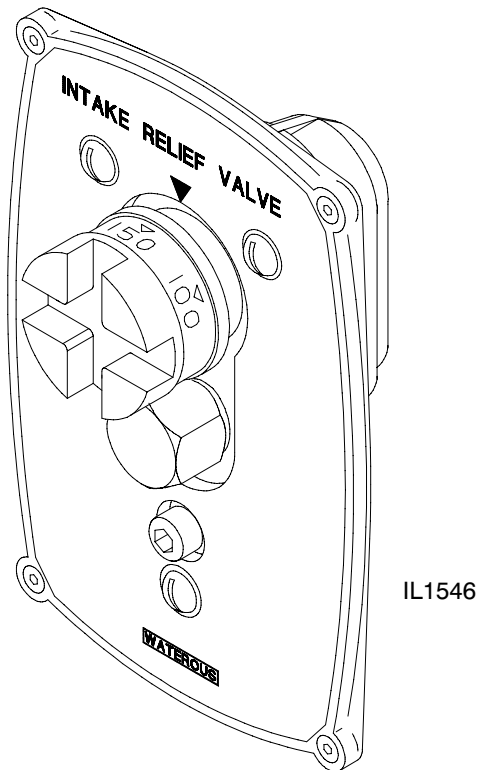

IL1546

After Pumping

If pumping anything but clean water, open the intake relief valve drain and flush entire system with clean, fresh water for several minutes to remove all traces of impurities.

CAUTION

If the intake relief valve is exposed to freezing temperatures, drain all water from the system. Failure to close drain will cause intake relief valve to dump continuously while pump is operating.

Figure 5. Relief Valve Outlet Warning Plate

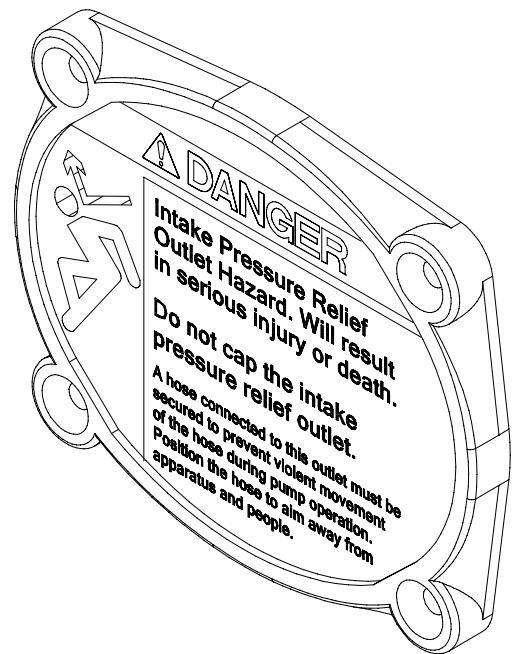

IL1547

NOTE:

Do not use chlorine cleaning solvents on this plate.

Maintenance Instructions

1. Clean the pilot valve strainer once per month, or as needed. Remove the screen using a 24 mm wrench. Clean and reinstall.
2. Clean the throttle screw once per month by removing it from the pilot valve. If the bore is plugged, it can be flushed out with water.
3. Test the intake relief valve system once a month with a pressurized water source capable of supplying continuous flow at 60 to 100 psi.
 - a) Set the pilot valve slightly above the source pressure and apply this pressure to the pump intake. Relief valve should remain closed.
 - b) Reduce pilot valve setting to slightly below source pressure. Relief valve should open, "dumping" a large volume of water.
 - c) Reset pilot valve above source pressure. Relief valve should close.
4. Perform pump dry vacuum test each month.
 - a) Close discharge and drain valves and similar openings.
 - b) Operate priming device to create a vacuum of about 22 in. Hg in pump, then stop primer and engine.
 - c) Watch pressure gauge. If vacuum drops more than 10 in. Hg in 5 minutes, listen for air leaks at the main valve outlet and pilot valve drain port and drain nipples.

Figure 6. Pilot Valve Maintenance

