

# Rotary Style Transfer Valve Actuators

# Overhaul Instructions

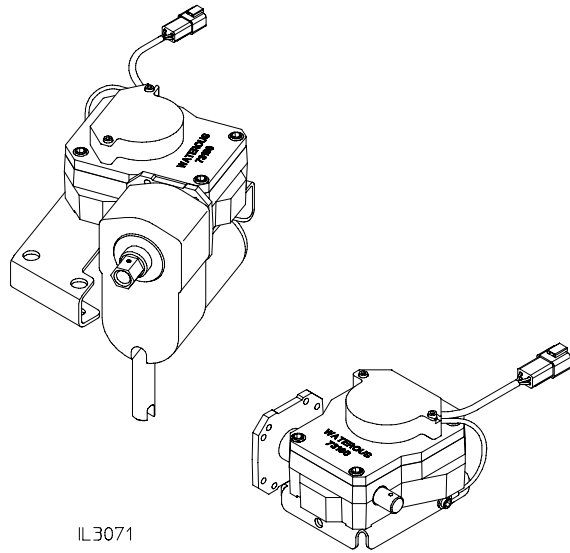
Form No.	Section	Issue Date	Rev. Date
F-1031	2315	12/10/99	11/02/11

## Table of Contents

- Introduction ..... 1
- Safety Instructions** ..... 1
- Actuator Mounting Variations** ..... 2
- Disassembly**
- Electric Actuators**
- Rotary Switch or Rotary Encoder Removal ... 3
- Sector Gear Removal ..... 4
- Worm Gear and Motor Removal ..... 5
- Mounting Bracket Removal ..... 6
- Manual Actuators**
- Rotary Switch or Rotary Encoder Removal ... 7
- Sector Gear Removal ..... 8
- Worm Gear Removal ..... 9
- Mounting Bracket Removal ..... 10
- Reassembly** ..... 11
- General Information ..... 11
- O-ring and Gasket Kit ..... 11
- Sector Gear ..... 11
- Gear Housing ..... 11
- Setting to Volume Position** ..... 11
- Transfer Valve Ball on Pump ..... 11
- Transfer Valve Actuator ..... 11
- Rotary Switch ..... 11
- Rotary Encoder ..... 11
- Rotary Encoder Grounding** ..... 11

## Illustrations

- 1. Electric Actuator Mounting Variations ..... 2
- 2. Manual Actuator Mounting Variations ..... 2
- 3. Rotary Switch Removal  
(Electric Actuators) ..... 3
- 4. Rotary Encoder Removal  
(Electric Actuators) ..... 3
- 5. Sector Gear Removal  
(Electric Actuators) ..... 4
- 6. Worm Gear and Motor Removal  
(Electric Actuators) ..... 5
- 7. Mounting Bracket Removal  
(Electric Actuators) ..... 6
- 8. Rotary Switch Removal  
(Manual Actuators) ..... 7
- 9. Rotary Encoder Removal  
(Manual Actuators) ..... 7
- 10. Sector Gear Removal (Manual Actuators) ... 8
- 11. Worm Gear Removal (Manual Actuators) .... 9
- 12. Mounting Bracket Removal  
(Manual Actuators) ..... 10
- 13. Sector Gear Installation ..... 12
- 14. Gear Housing Lubrication ..... 12
- 15. Setting Actuator to Volume Position ..... 12
- 16. Setting Rotary Switch to Volume Position ... 13
- 17. Setting Rotary Encoder to Volume  
Position ..... 13
- 18. Rotary Encoder Ground Wire ..... 14



**WATEROUS**  
*Fire Pumps – Since 1886*



## Introduction

### Notes:

1. **Rotary Style Actuators are used on CM Series Pumps built from 1/1/2000 to the present.**
2. **For overhaul of Reciprocating Style Actuators used on CM Series Pumps prior to 1/1/2000, see F-1031, Section 4212, *CM Series Pump Overhaul Instructions*.**
3. **These instructions are intended to be performed once the actuator has been removed from the pump. See F-1031, Section 4212, *CM Series Pump Overhaul Instructions* for steps required to remove the actuator from the pump.**

The Waterous transfer valve actuator, offered on Waterous two-stage CM series pumps, permits a smooth changing of the transfer valve position to either pressure or volume. Available in either electric or manual operation and top or bottom mounted.

The electric transfer valve actuator has panel mounted push buttons that give the pump operator finger tip control of the transfer valve. Colored indicator lights on the switch plate show the transfer valve position, for both manual and electric transfer valve actuators.

The electric transfer valve actuator has an optional manual override provision which permits manual transfer valve operation from a control panel.

## Safety Instructions



### WARNING

**Moving or rotating parts hazard. May cause injury to fingers.**

Do not operate the transfer valve actuator with the gear box cover removed to prevent injury to fingers.



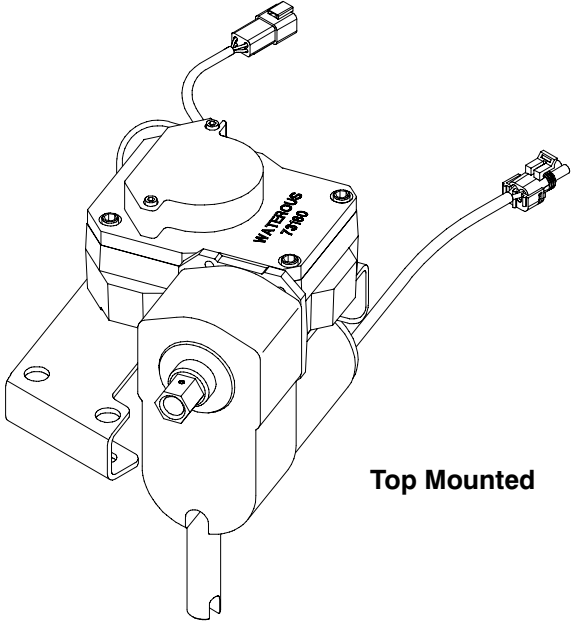
### WARNING

**Voltage Hazard. May cause personal injury**

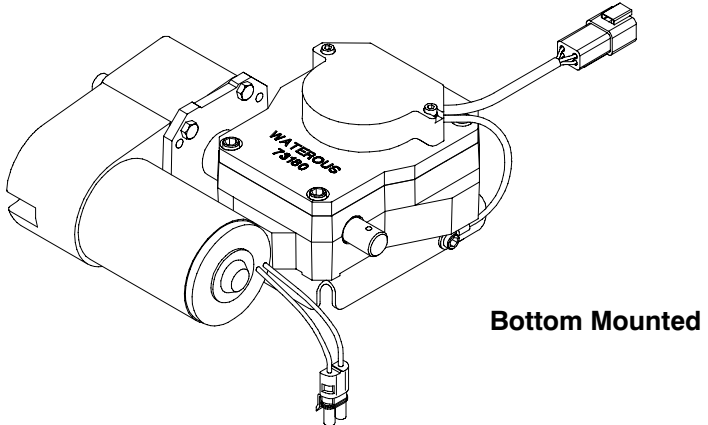
Disconnect power when repairing the transfer valve actuator to prevent accidental shock.

# Actuator Mounting Variations

Figure 1. Electric Actuators

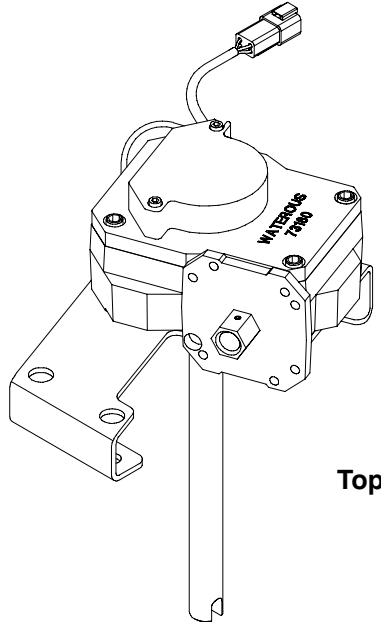


Top Mounted

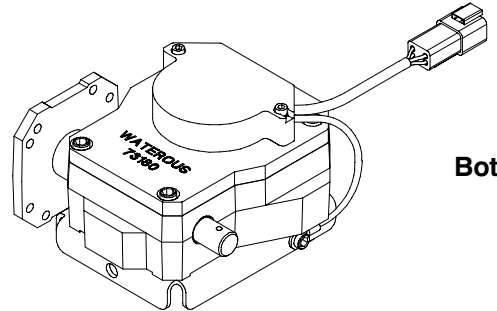


Bottom Mounted

Figure 2. Manual Actuators



Top Mounted



Bottom Mounted

IL2794

# Disassembly - Electric Actuators

## Rotary Switch or Rotary Encoder Removal

1. For removal of transfer valve actuator from CM pump, see F1031, Section 4212, *CM Series Pump Overhaul Instructions*.

2. Make sure power is disconnected before disassembling any part of the transfer valve actuator assembly.

3. **Pumps with Rotary Switch**  
(Built Prior to 11/6/2006)

— See Figure 3 —

Remove the switch from housing by removing the two #8-32 x 7/8 in. screws indicated. The switch, switch bracket and cable will be removed as one unit.

Disconnect rotary encoder cable from the power supply and wires to panel lights.

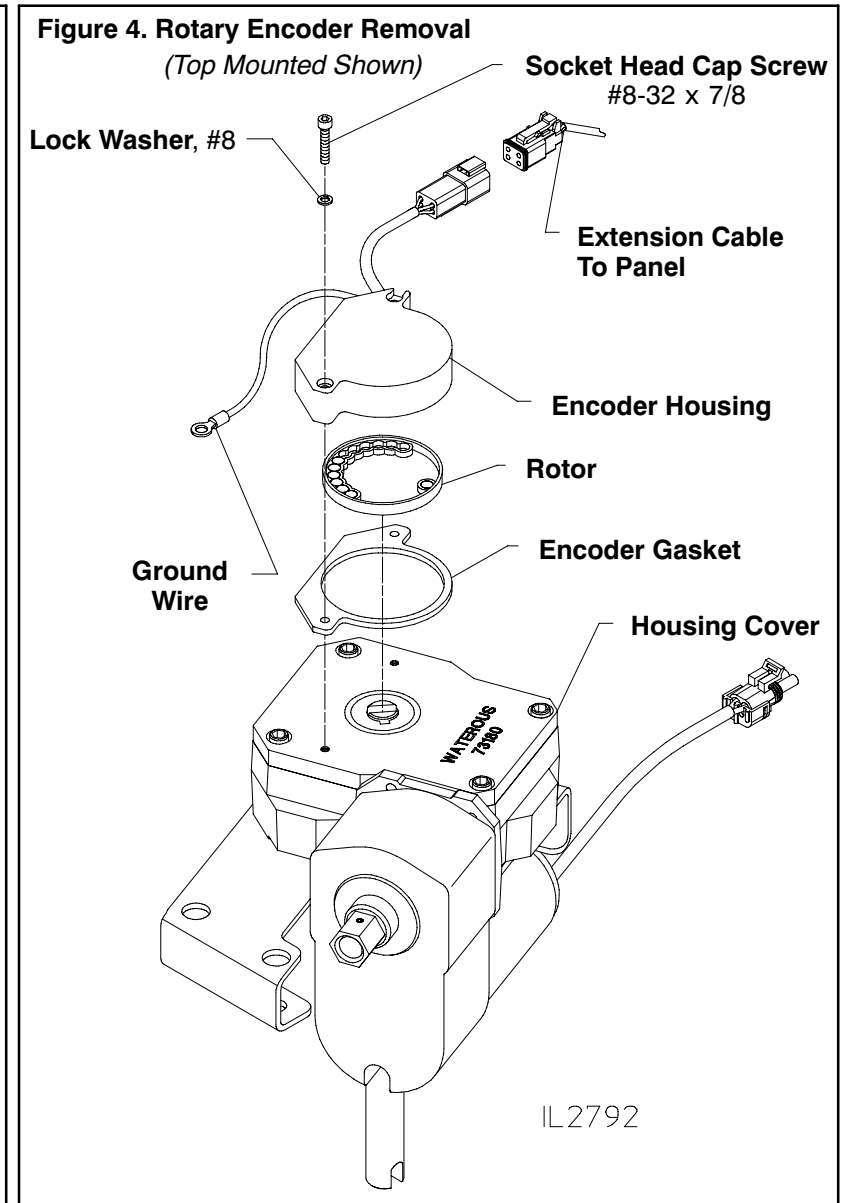
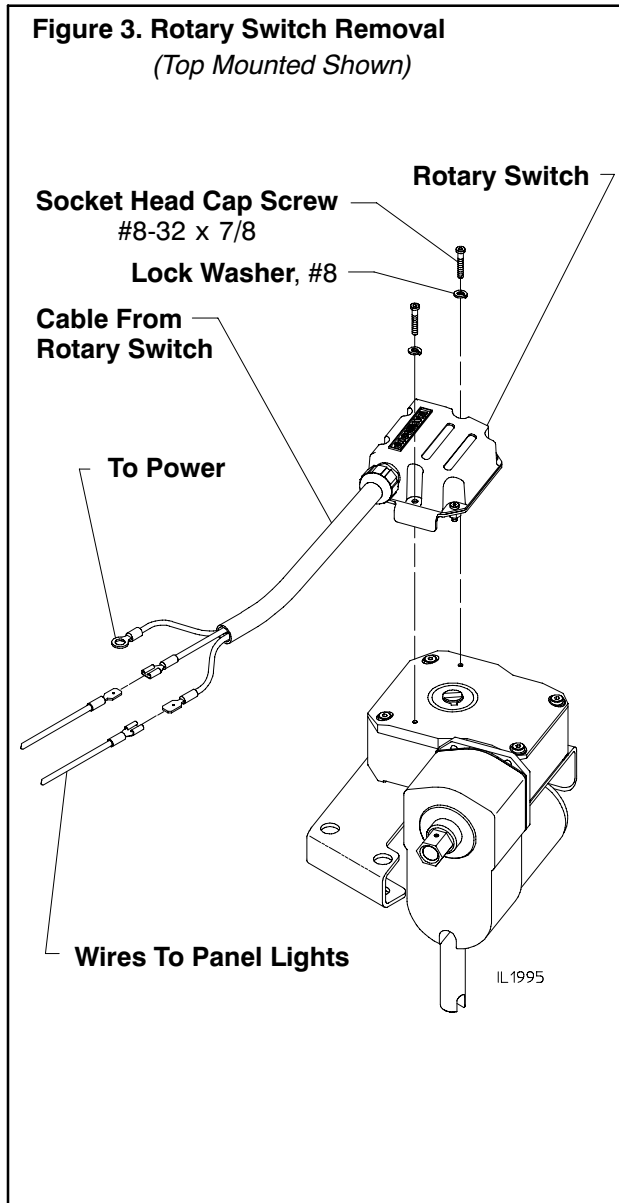
**Pumps with Rotary Encoder**  
(Built After 11/6/2006)

— See Figure 4 —

Remove the encoder from housing by removing the two #8-32 x 7/8 in. screws. The ground wire may also need to be disconnected from the bracket (see Figures 4 & 18).

**Note: Be careful when removing the encoder, the rotor is a loose piece and can be damaged if dropped.**

Disconnect the encoder from the extension cable.



## Disassembly - Electric Actuators

### Sector Gear Removal

1. Remove housing cover by removing four screws (1/4-20 x 5/8) and four lock washers (1/4).
2. Slide sector worm gear and limit disk off of extension shaft. Note that the worm gear may need to be rotated to aid in removing sector worm gear. Key (3/16 x 1-1/4) may still be attached to extension shaft. Remove only if damaged.

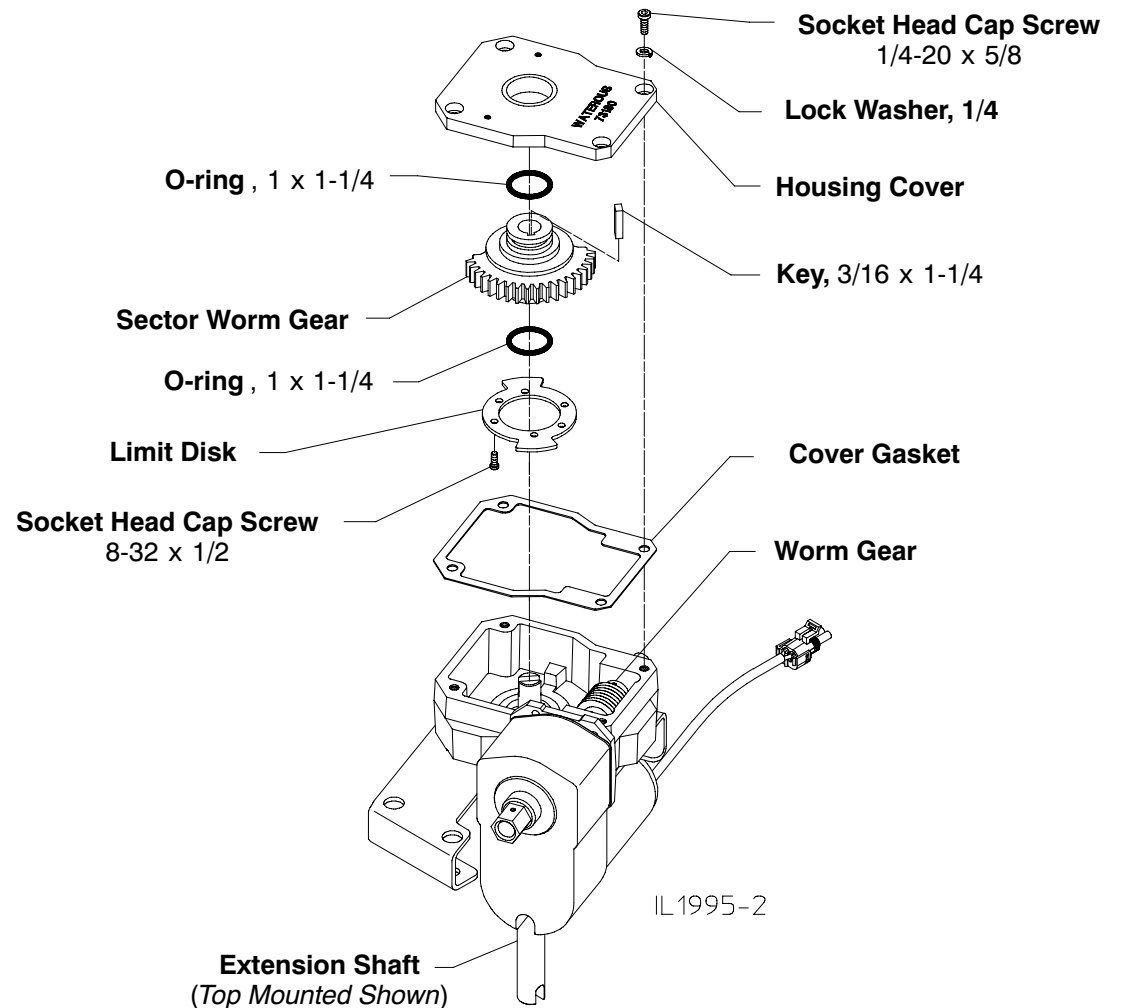
**NOTE: On transfer valve actuators built prior to 4/21/06, a 3/16 x 3/4 key was used. The service parts list originally provided will identify the correct key length if replacement is needed.**

3. Separate limit disk from sector worm gear if necessary by removing six screws (8/32 x 1/2).

**NOTE: On transfer valve actuators built prior to 11/27/02, low head socket screws with lock washers were used for attachment of limit disk to sector worm gear. If replacing this mounting hardware, use #8-32 x 1/2 socket head cap screws with a removable strength thread locker, i.e. Loctite® 242 (do not use lock washers).**

4. Remove two O-rings (1 x 1-1/4) only if parts are damaged. Order O-ring/Gasket Kit K-953 if repair is needed.

**Figure 5. Sector Gear Removal**  
(Top Mounted Shown)



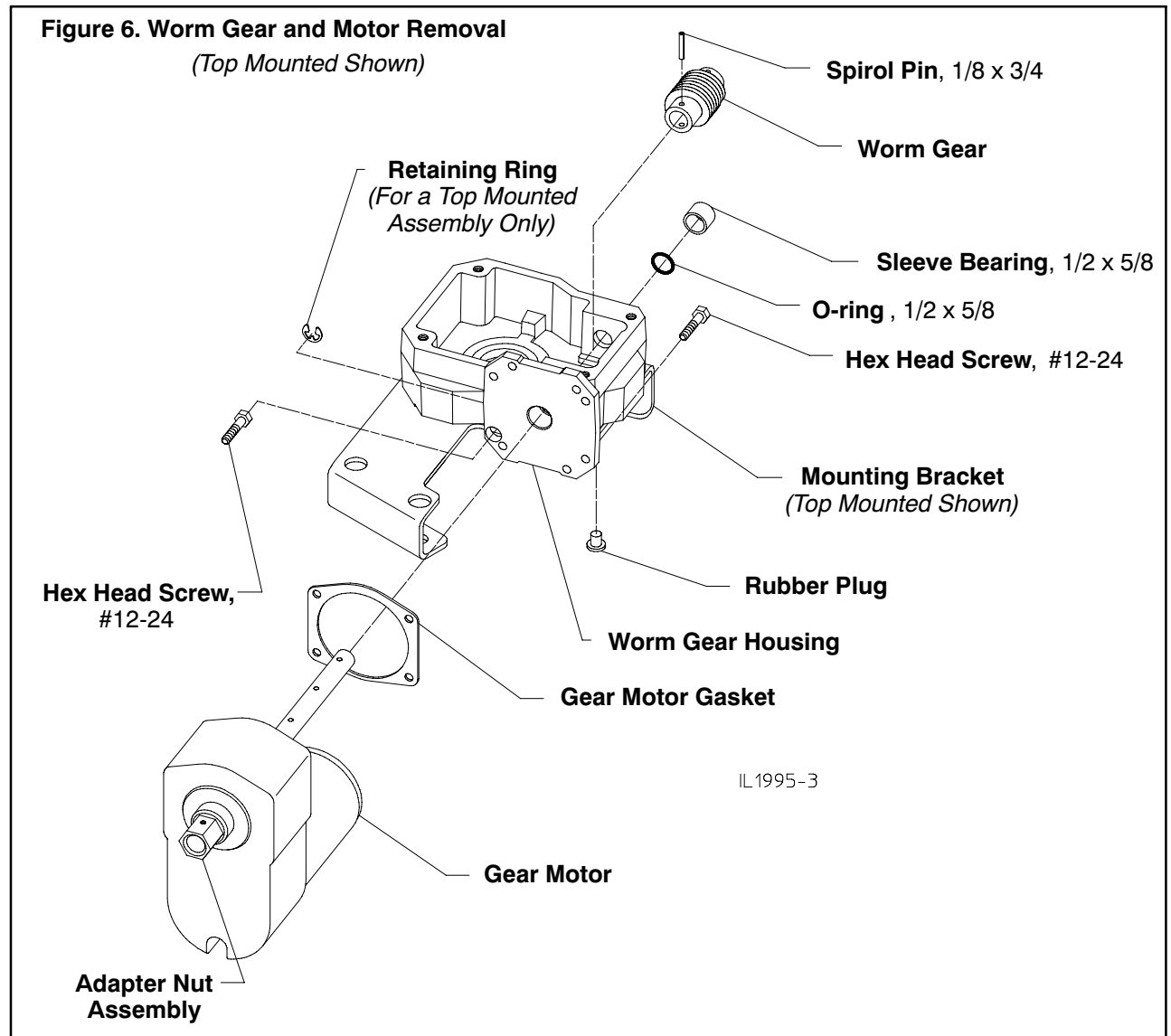
## Disassembly - Electric Actuators

### Worm Gear and Motor Removal

1. Remove two rubber plugs from worm gear housing.
2. Drive two spirol pins, 1/8 x 3/4 out through worm gear and rubber plug holes.
3. If adapter nut assembly is attached to opposite side of worm gear housing (not shown), drive spirol pin (1/8 x 3/4) out to remove adapter nut.
4. Remove gear motor and gasket from worm gear housing by removing four hex head screws (#12-24). For a top mounted assembly, also remove retaining ring. Slide gear motor out from worm gear housing.

**NOTE: It may be necessary to remove the mounting bracket in order to remove the #12-24 screws (see Figure 6).**

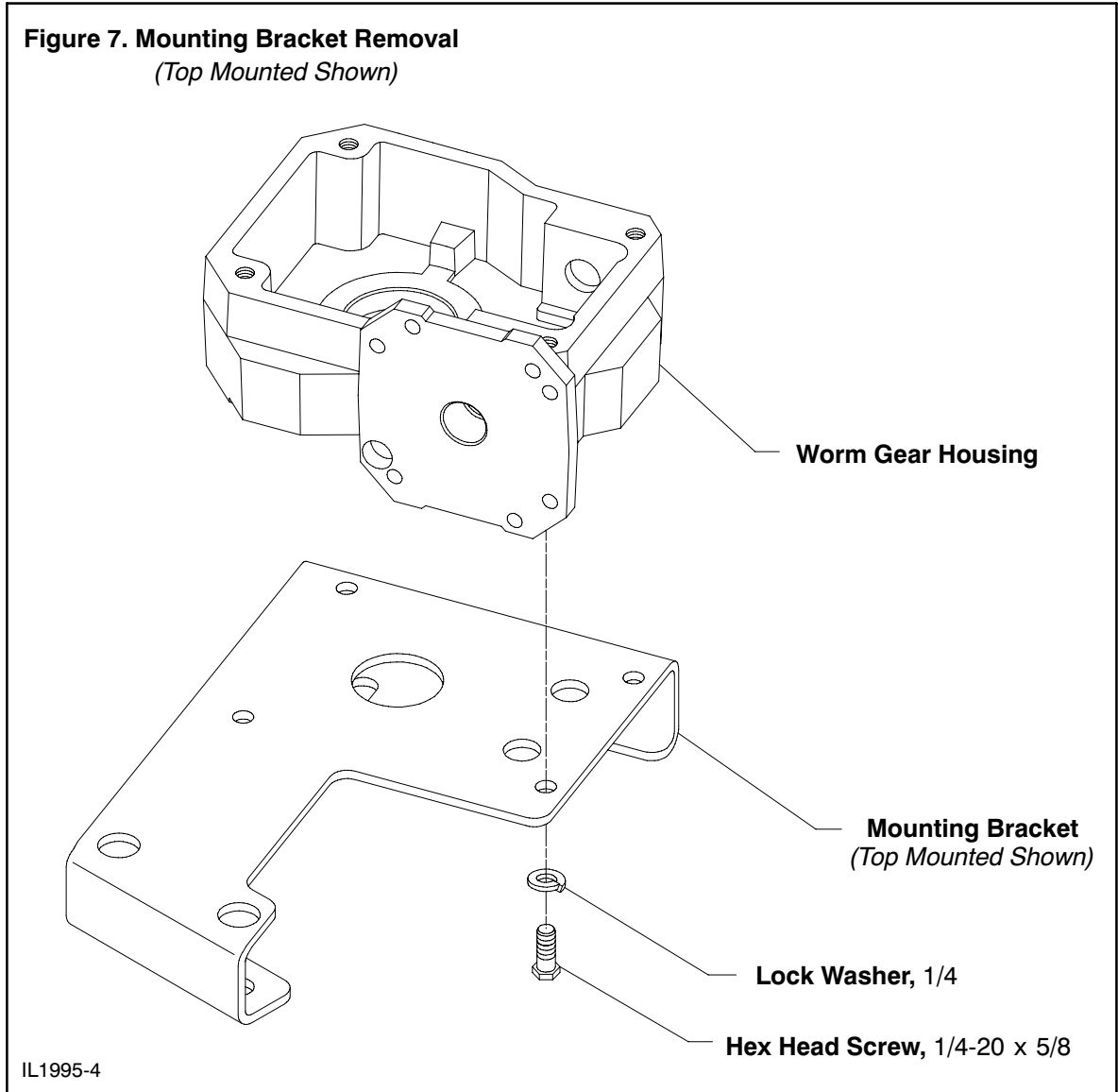
5. Worm gear will become loose after completing steps 1-4.
6. Remove sleeve bearing (1/2 x 5/8) and O-ring (1/2 x 5/8) only if parts are damaged.



## Disassembly - Electric Actuators

### Mounting Bracket Removal

1. Remove worm gear housing from mounting bracket by removing four hex head screws (1/4-20 x 5/8).



# Disassembly - Manual Actuators

## Rotary Encoder Removal

1. For removal of transfer valve actuator from CM pump, see F1031, Section 4212, *CM Series Pump Overhaul Instructions*.
2. Make sure power is disconnected before disassembling any part of the transfer valve actuator assembly.

### 3. Pumps with Rotary Switch

(Built Prior to 11/6/2006)

#### See Figure 8

Remove the switch from housing by removing the two #8-32 x 7/8 in. screws indicated. The switch, switch bracket and cable will be removed as one unit.

Disconnect rotary encoder cable from the over supply and wires to panel lights.

### Pumps with Rotary Encoder

(Built After 11/6/2006)

#### See Figure 9

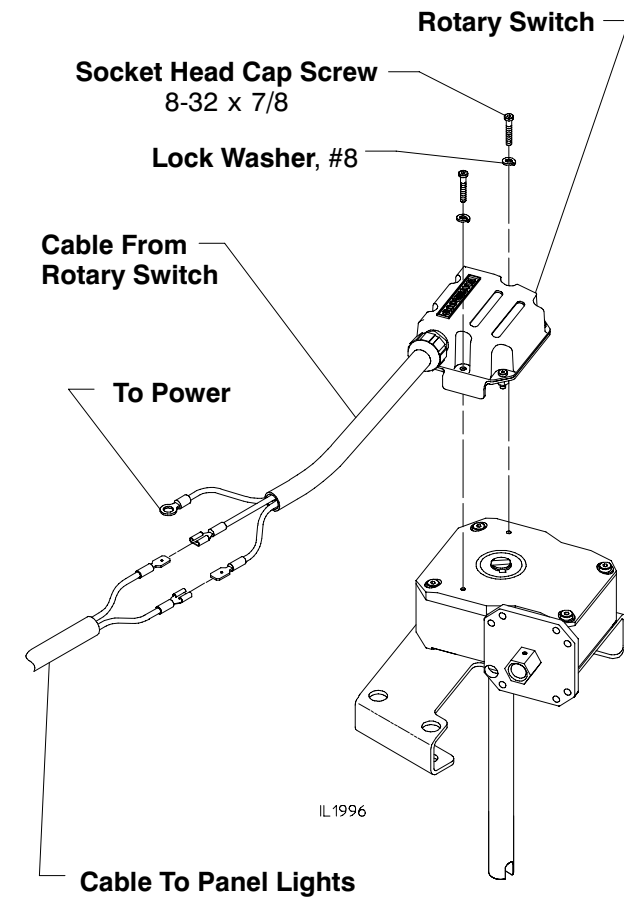
Remove the encoder from housing by removing the two #8-32 x 7/8 in. screws. The ground wire may also need to be disconnected from the bracket (see Figure 4).

**Note: Be careful when removing the encoder, the rotor is a loose piece and can be damaged if dropped.**

Disconnect the encoder from the extension cable.

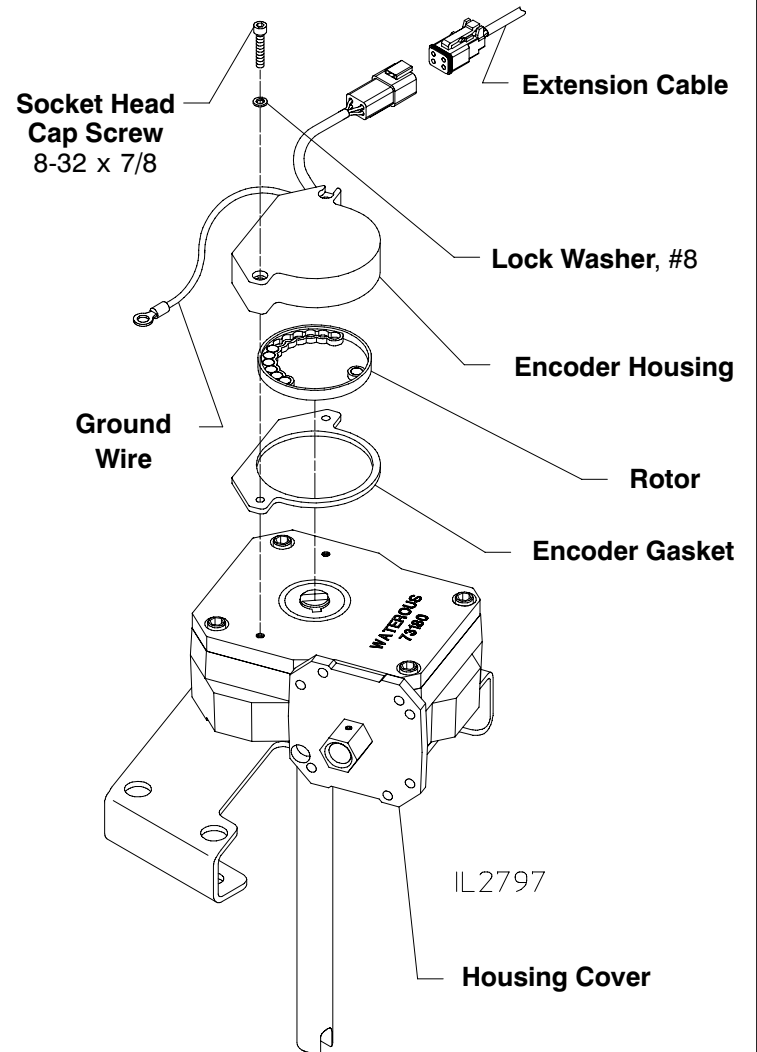
**Figure 8. Rotary Switch Removal**

(Top Mounted Shown)



**Figure 9. Rotary Encoder Removal**

(Top Mounted Shown)





## Disassembly - Manual Actuators

### Sector Gear Removal

1. Remove housing cover by removing four screws (1/4-20 x 5/8) and four lock washers (1/4).
2. Slide sector worm gear and limit disk off of extension shaft. Note that the worm gear may need to be rotated to aid in removing sector worm gear. Key (3/16 x 1-1/4) may still be attached to extension shaft. Remove only if damaged.

**NOTE: On transfer valve actuators built prior to 4/21/06, a 3/16 x 3/4 key was used. The service parts list originally provided will identify the correct key length if replacement is needed.**

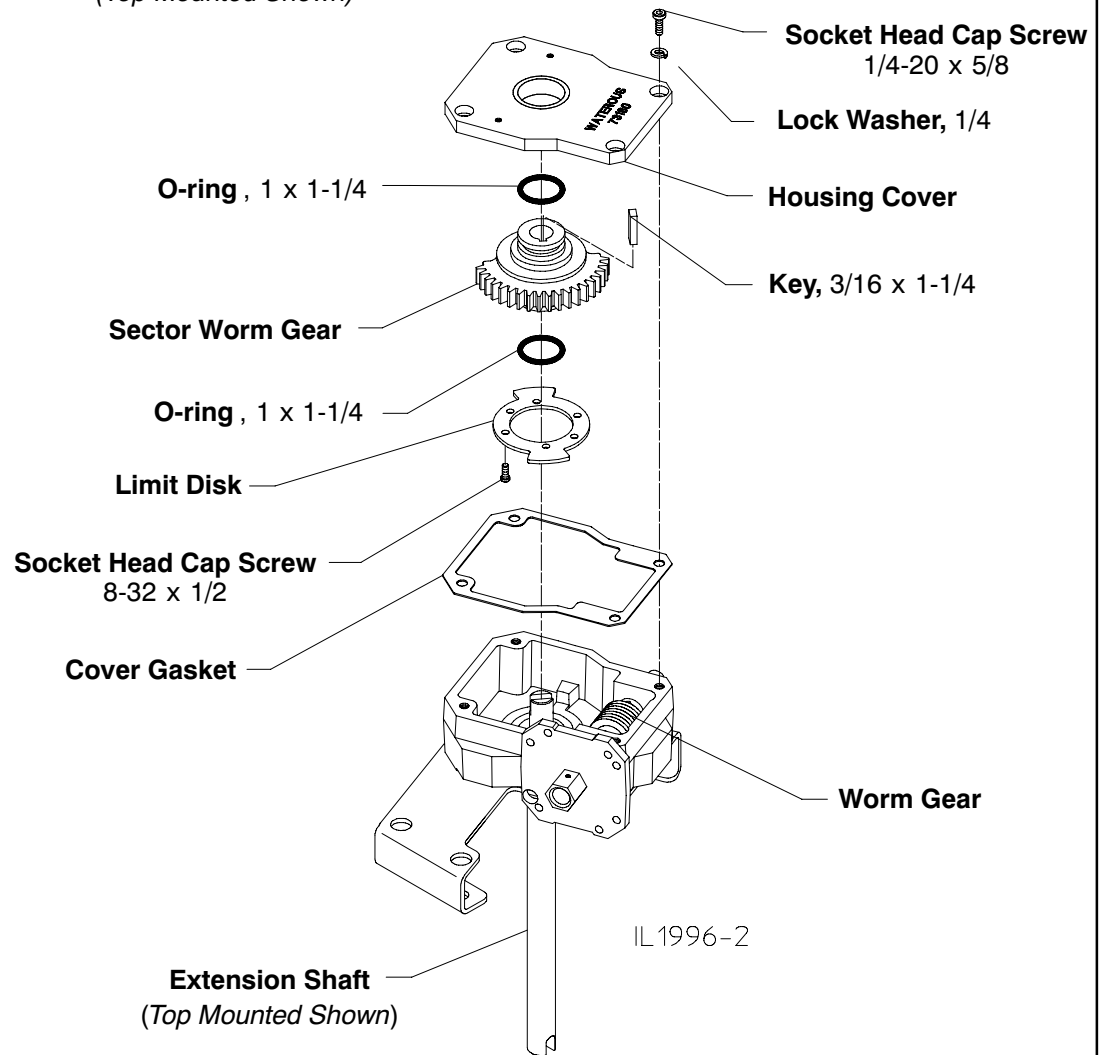
3. Separate limit disk from sector worm gear if necessary by removing six screws (8/32 x 1/2).

**NOTE: On transfer valve actuators built prior to 11/27/02, low head socket screws with lock washers were used for attachment of limit disk to sector worm gear. If replacing this mounting hardware, use #8-32 x 1/2 socket head cap screws with a removable strength thread locker, i.e. Loctite® 242 (do not use lock washers).**

4. Remove two O-rings (1 x 1-1/4) only if parts are damaged. Order O-ring/Gasket Kit K-953 if repair is needed.

**Figure 10. Sector Gear Removal**

*(Top Mounted Shown)*

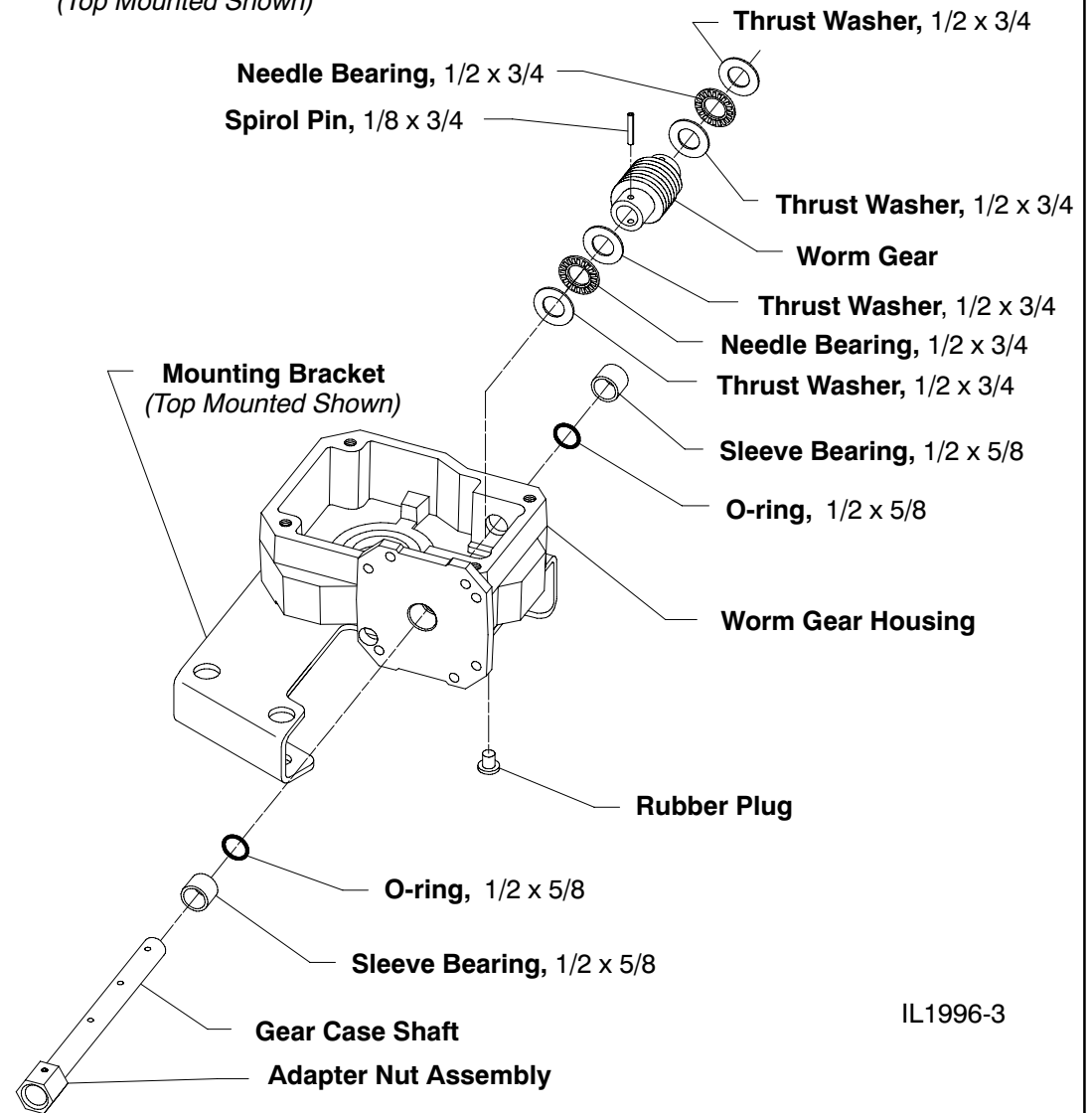


# Disassembly - Manual Actuators

## Worm Gear Removal

1. Remove two rubber plugs from worm gear housing.
2. Drive two spirol pins, 1/8 x 3/4 out through worm gear and rubber plug holes.
3. From adapter nut assembly side of worm gear housing remove gear case shaft.
4. Worm gear, two needle bearings (1/2 x 3/4) and four thrust washers (1/2 x 3/4) will become loose after completing steps 1-3.
5. Remove two sleeve bearings (1/2 x 5/8) and two O-rings (1/2 x 5/8) only if parts are damaged.

**Figure 11. Worm Gear Removal**  
(Top Mounted Shown)

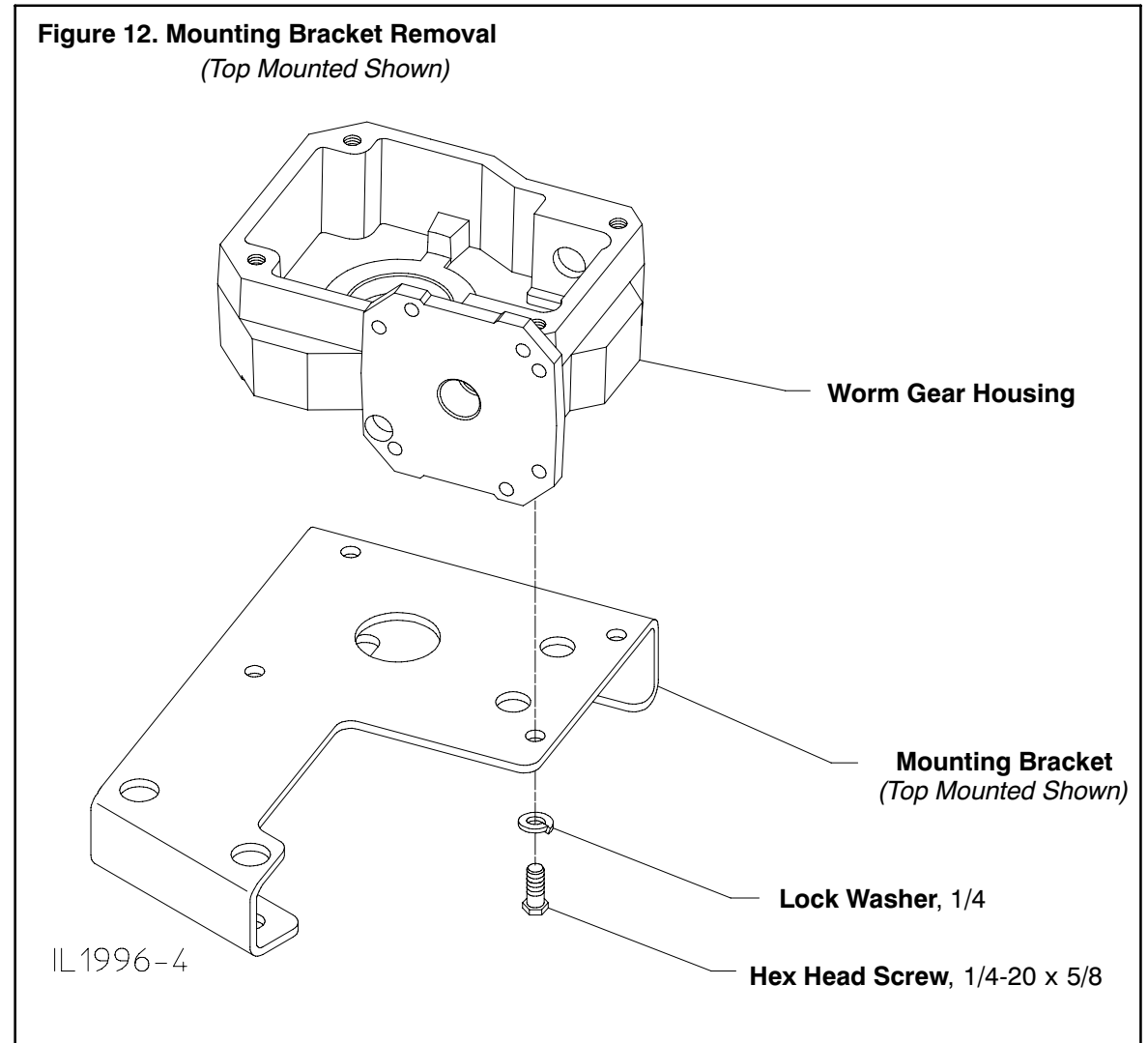


IL1996-3

## Disassembly - Manual Actuators

### Mounting Bracket Removal

1. Remove worm gear housing from mounting bracket by removing four hex head screws (1/4-20 x 5/8).



---

## Reassembly

---

1. Reassembly is basically the reverse of disassembly.
2. All O-rings and gaskets needed for repair of transfer valve actuators are available in a single kit. Contact a Waterous service specialist at 1-651-450-5200 to order.
3. Pay close attention to these areas when reassembling (the diagrams referred to are on the following pages):
  - a. **Sector Gear** (See Figure 13):

When attaching the limit disk to the sector gear, use a removable strength thread locker such as Loctite no. 242. Do not use lockwashers.
  - b. **Gear Housing** (See Figure 14):

Pack with a multi-purpose grease before installing cover.
  - c. **Setting to Volume Position:**

The transfer valve on the pump and the actuator should be in the "Volume" position to ensure the position indicator lights display correctly.

    1. **Transfer Valve Ball on the Pump:** Ensure the volume markings on the valve ball and ball housing cover are aligned. See F-1031, Section 4212, *CM Overhaul Instructions* for details.
    2. **Transfer Valve Actuator:** (See Figure 15): Ensure the actuator sector is rotated to the volume position. A marking on the underside of the bracket shows the direction the stem should be turned to position the actuator in volume. Turn the stem in the direction of the arrow until the internal stop is reached.
  - d. **Position the Rotary Switch or Encoder in the Volume Position:**
    1. **Pumps with Rotary Switch** (Built Prior to 11/6/2006), See Figure 16):

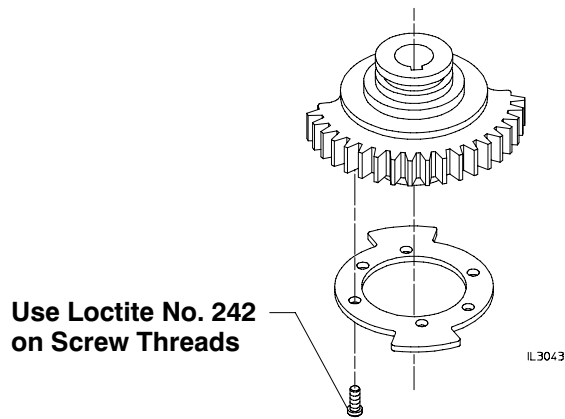
Rotate the switch so that the tang on the underside aligns with the slot in the shaft on the top of the actuator.
    2. **Pumps with Rotary Encoder** (Built After 11/6/2006), See Figure 17):

Rotate the tang on the underside of the encoder so that the arrow aligns with the mark indicated in the diagrams.
  - e. **Ensure the Encoder is Grounded Correctly:**

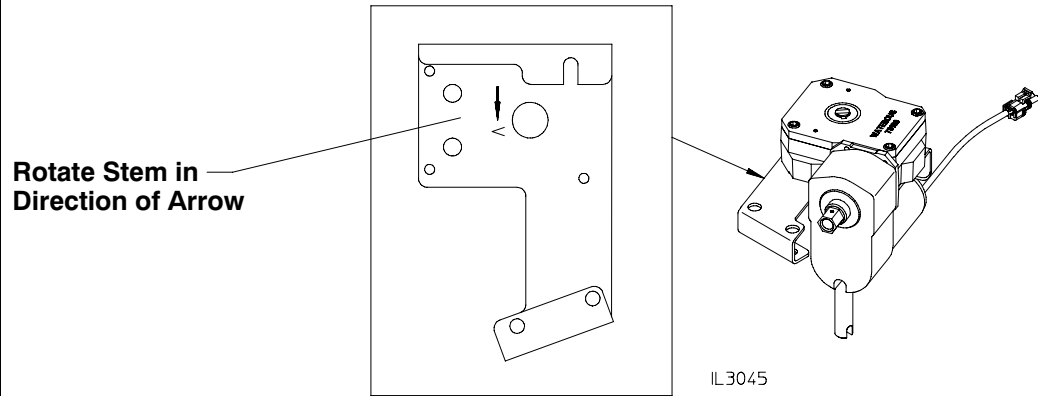
See Figure 18 for location of ground wire.

# Reassembly

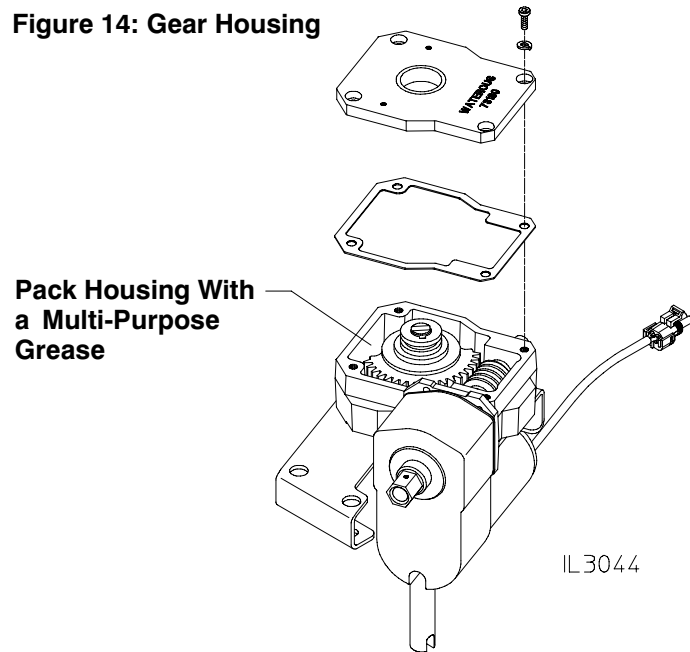
**Figure 13: Sector Gear Installation**



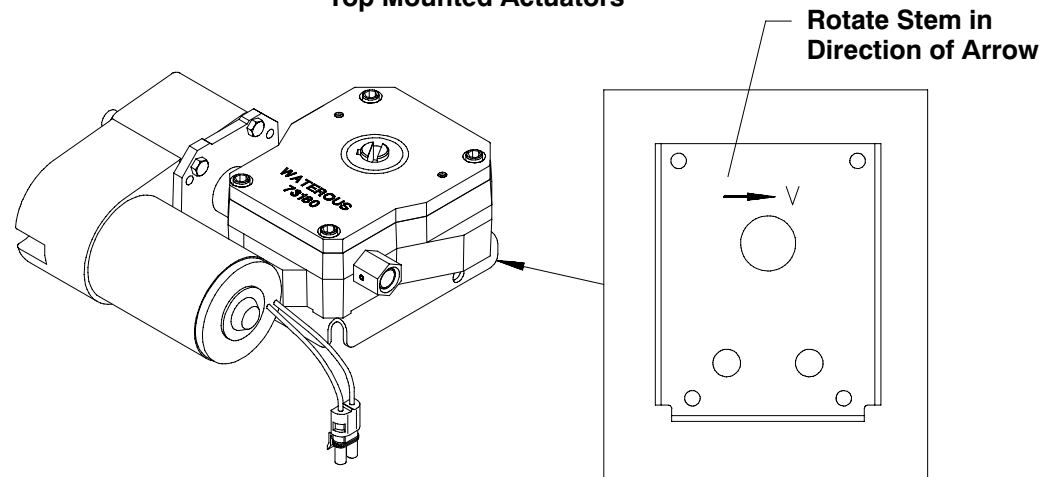
**Figure 15: Setting Actuator to Volume Position**



**Figure 14: Gear Housing**



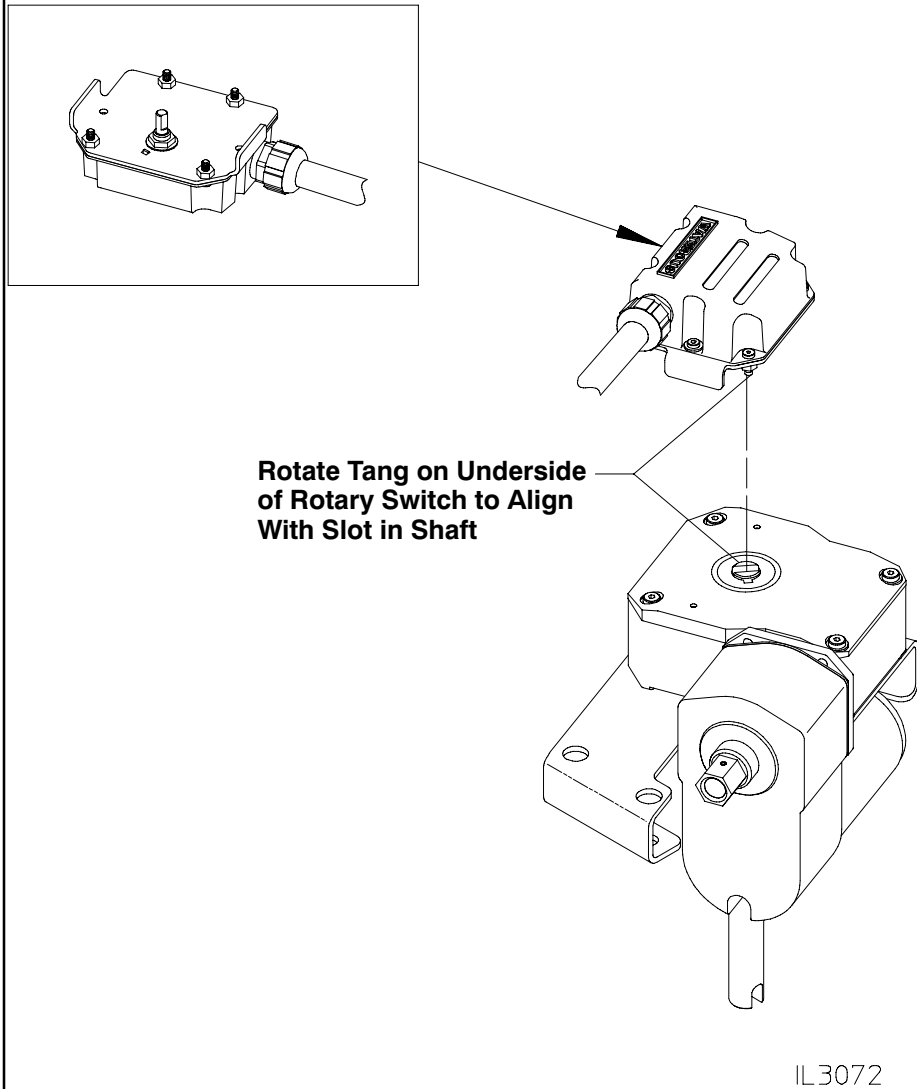
**Top Mounted Actuators**



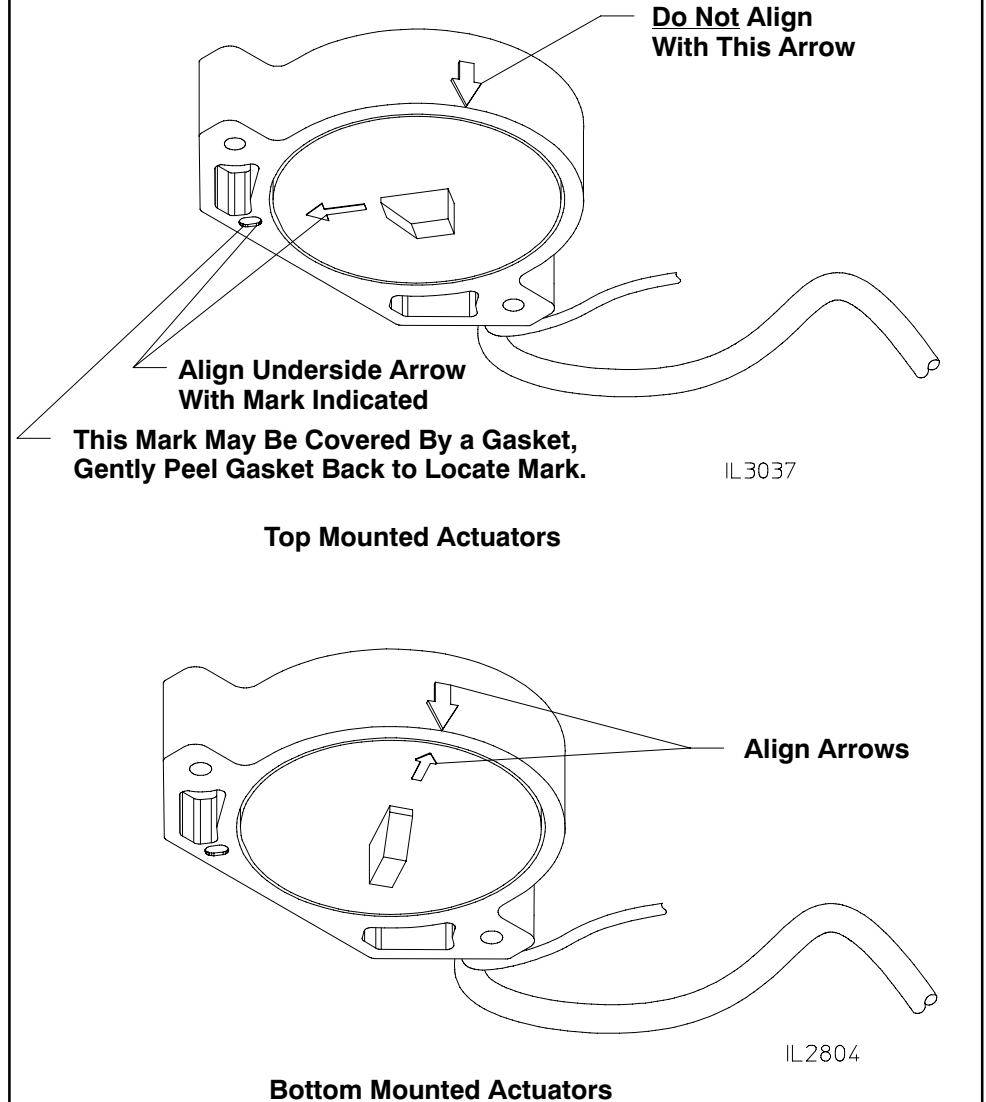
**Bottom Mounted Actuators**

# Reassembly

**Figure 16: Setting Rotary Switch to Volume Position**

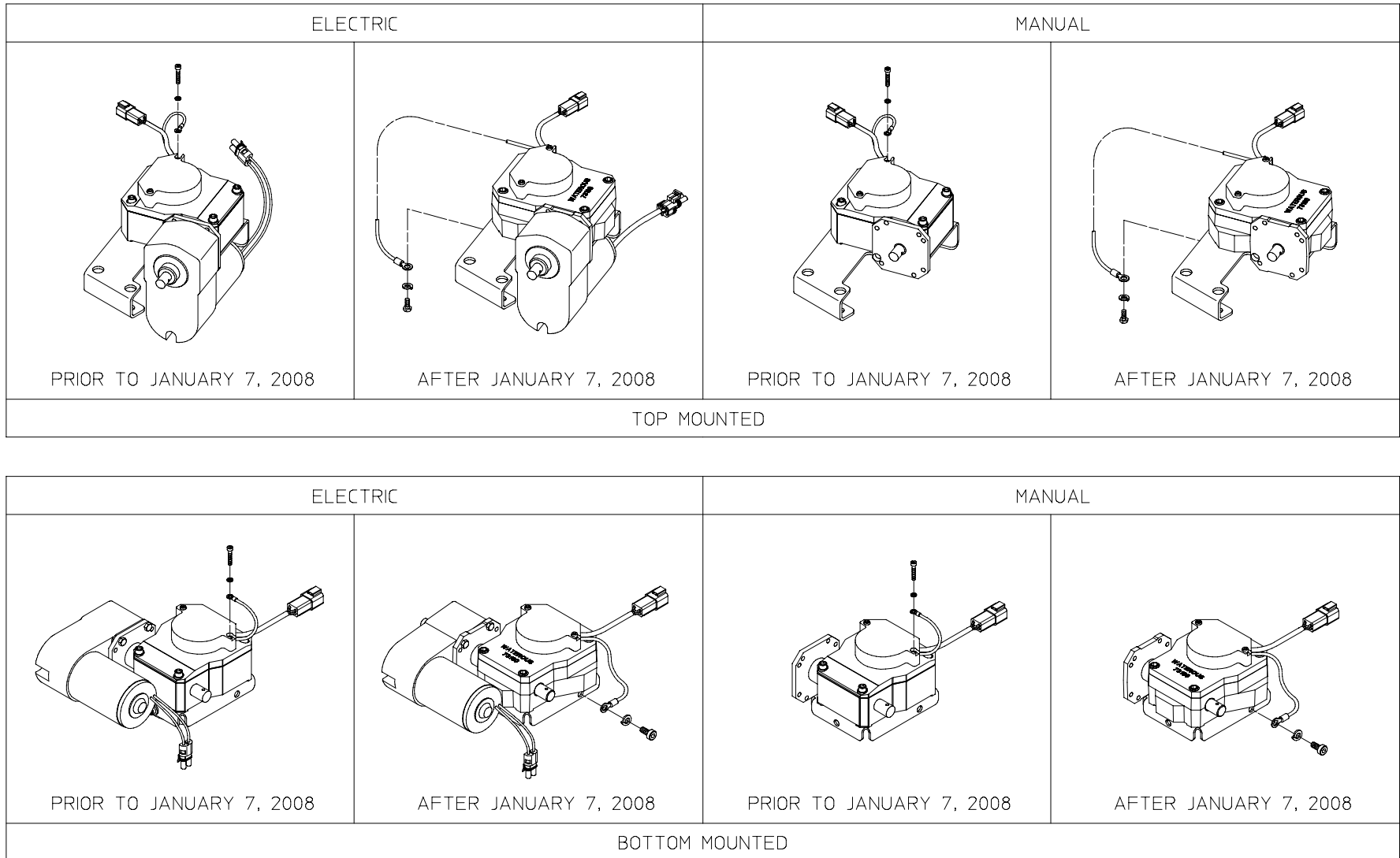


**Figure 17: Setting Rotary Encoder to Volume Position**



# Reassembly

**Figure 18: Rotary Encoder Ground Wire**



IL2815