

HL Series Centrifugal Fire Pumps Operation and Maintenance Instructions

Table of Contents

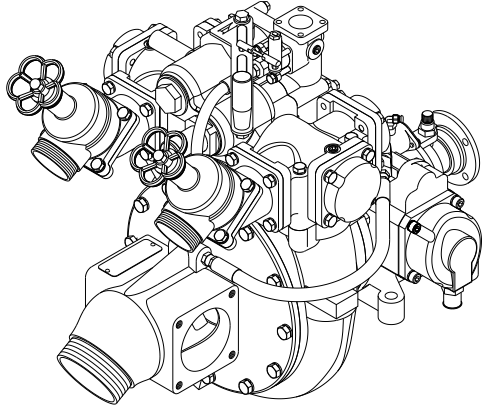

IL2272



Read through the safety information and operating instructions carefully before using your Waterous HL Series Fire Pump.

NOTE: Instructions subject to change without notice

EC Declaration of Incorporation	2
Safety Information -----	3, 4
Introduction	5
General Description	5
Operational Limits	5
Available Pump Models	5
Components	6, 7
Operating Instructions	8
Low Pressure Mode	8
High Pressure Mode	8
Pumping from Hydrant or in Relay	9
Pumping from Tank	10
Pumping from Draft	11
RTP Foam System	12
Control Panel	13
Fire Hose Testing.....	14
Maintenance	15
Service Parts	15
Mechanical Seal.....	15
High Pressure Inlet Strainer	16
Lubrication	17
Direct Drive Models HL200D, HL300D and HL400D.....	17
Gear Drive Models HL200K, HL300K and HL400K	18
Testing	19



EC Declaration of Incorporation

Manufacturers Name: Waterous Company

Manufacturers Address: 125 Hardman Avenue South, South St. Paul, Minnesota 55075, USA

Declare that the partly completed machinery described below, complies with the following health and safety requirements of Part 1 of Annex 1 of the Machinery Directive 2006/42/EC.

Parts 1.1.1, 1.1.2, 1.1.3, 1.1.5, 1.1.6, 1.3.1, 1.3.2, 1.3.3, 1.3.4, 1.3.7, 1.3.8, 1.4.1, 1.4.2, 1.5.1, 1.5.2, 1.5.3, 1.5.4, 1.5.5, 1.5.6, 1.5.7, 1.5.8, 1.5.9, 1.5.13, 1.6.1, 1.6.4, 1.7.1, 1.7.2, 1.7.3, and 1.7.4.

Description: Pump

Model Number: HL300

Serial Number:

Partly completed machinery must not be put into service until the final machinery into which it is incorporated has been declared to be in conformity with the provisions of the Machinery Directive.

Confidential technical documentation has been compiled in accordance with Part B of Annex VII of Machinery Directive 2006/42/EC. Relevant information on the partly completed machinery is available to European National Authorities on written request only. The documentation will be transmitted via post and (or) presented in person by Waterous personnel.

The following standards have been observed with in-part or in-full as applicable:

EN1028-1

EN1028-2

Full Name of responsible person (Typed).

William L. Smith

Position President

Signature

Date 10/08/2010

Full Name of Authorized European Representative (Typed).

Dejan Marinkovic

Position Manažer prodeje pro Evropu

Signature

Date 10/08/2010

Safety Information



Read through the safety information and operating instructions before using your Waterous Fire Pump.

WARNING

Death or serious personal injury might occur if proper operating procedures are not followed. The pump operator, as well as individuals connecting supply or discharge hoses to the apparatus must be familiar with these pump operating instructions as well as other operating instructions and manuals for the apparatus, water hydraulics and component limitation.

WARNING

Pressure Hazard. May result in personal injury.

Prior to connection or removal of hoses, caps or other closures with pump intake or pump discharge connections, relieve pressure by opening drains or bleeder valves. Bleeder valves should also be used while filling a hose connected to an intake with water.

WARNING

Scalding Water Hazard. May result in serious burns.

When operating the pump, be sure to open at least one discharge valve slightly to prevent the pump from overheating. If the pump runs for a few minutes completely closed, it may heat the water enough to scald someone when the valve is opened. Overheating can damage the packing, seals and other pump parts. If the apparatus builder has installed a by-pass system or other provision designed to prevent overheating, opening a discharge valve may be unnecessary.

WARNING

Unexpected Truck Movement. May result in serious personal injury or death.

Failure to properly shift transmission in accordance to the transmission operation instructions may result in unexpected truck movement which may result in serious personal injury or death.

Intended Uses

The HL series pump is a centrifugal water pump that is intended to be used for firefighting operations. It is an incomplete machine that is intended to be incorporated into completed apparatus such as firefighting vehicles.

The HL series pump is not intended to pump fuels, combustible liquids, oil, solids or slurries.

Operator Training

It is intended that the HL series pumps will be operated by personnel trained in firefighting tactics and the use of centrifugal firefighting water pumps.

Noise

While the pump is in operation, use appropriate ear protection to guard against the noise generated by the pump.

The maximum sound pressure level is 85dB as measured at factory conditions.

Pump Operation

- Make sure all rotating components are adequately guarded to prevent accidental contact.
- Do not place any object or hand into the intake of the pump while in operation.
- Do not disconnect the discharge hoses while they are pressurized.
- Do not unfasten any component while the pump is in operation.
- Use suitable hoists or lifting devices when removing or installing the pump.

Safety Information



Read through the safety information and operating instructions before using your Waterous Fire Pump.



WARNING

Hose Testing Hazard. May result in serious personal injury.

Due to a potential for catastrophic hose failure during service testing of fire hose, it is vital that safety precautions be taken to prevent exposure of anyone to this danger. Fire pumps on fire department apparatus are not designed for and should not be used for service testing of fire hoses. Hose testing machines should be used for service testing of fire hoses.



WARNING

Pressure Hazard. May result in serious personal injury.

If a fire pump on a fire department apparatus is used for service testing of fire hoses, the procedures in NFPA 1962 **MUST be followed** including the use of a fire department gate valve with a ¼-inch (6 mm) hole drilled through the gate installed between the fire apparatus discharge outlet and the hose test layout to prevent a volume surge from the pump in the event a hose bursts during testing.



WARNING

Scalding Water Hazard. May result in serious burns.

If a fire pump on a fire department apparatus is used for service testing of fire hoses, pump discharge water must be circulated through a by-pass system or discharged through a slightly open discharge valve, or some other provision must be used to prevent overheating. If the pump runs for a few minutes without adequate flow through the pump, water may be heated enough to scald someone when a valve is opened.

Introduction

This instruction contains the information needed for operation and maintenance of the HL Series fire pump.

General Description

The HL series are pedestal mounted fire pumps designed to operate in two modes:

Low Pressure Mode

Pump only low pressure water.

High Pressure Mode

Simultaneously pump low and high pressure water.

Three performance levels are available:

Low Pressure	High Pressure	Model Series
2000 L/min @ 10 bar	400 L/min @ 40 bar	HL200
3000 L/min @ 10 bar	400 L/min @ 40 bar	HL300
4000 L/min @ 10 bar	400 L/min @ 40 bar	HL400

Before operating the HL pump, read the following instructions carefully.

Operational Limits

Maximum Low Pressure

Control the speed of the pump so that the maximum low pressure is limited to 17 bar.

Maximum High Pressure

The maximum high pressure is internally limited by the high pressure relief valve not to exceed 55 bar.

Maximum Angle of Inclination

The maximum angle of inclination for pump operation is 15 degrees.

Maximum Pump Speed

The pump has a maximum operating speed of 3450 rpm. Do not exceed this speed.

Maximum Priming Speed

When priming, the pump speed should be limited to 2600 rpm.

Available Pump Models

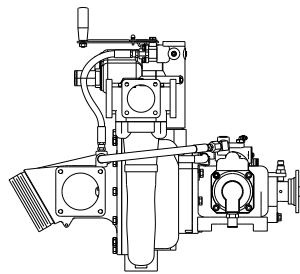

HL200D/300D

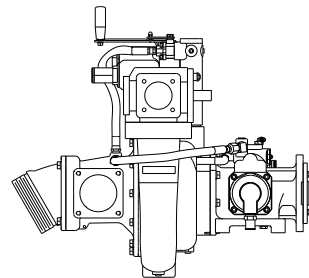

HL400D

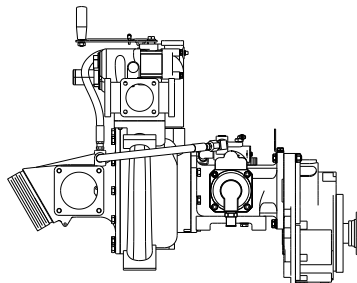

HL200K/300K

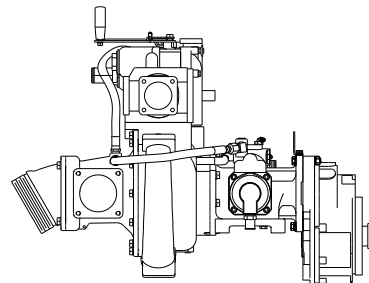

HL400K

IL3550

Components

NOTICE

HL Series Pumps are available constructed in aluminum or bronze materials.

Body Assembly

The body is constructed of corrosion-resistant anodized aluminum or bronze.

Low Pressure Impeller

The low pressure impeller is constructed of a wear-resistant anodized aluminum or bronze with flame plated hubs.

High Pressure Impeller

The high pressure impeller is constructed of bronze for both aluminum and bronze pumps.

Impeller Shaft Assembly

The impeller shaft assembly consists of the low and high pressure impellers mounted on a stainless steel shaft with a maintenance-free mechanical seal and related parts.

Pump Intake

The pump intake is constructed of corrosion-resistant anodized aluminum or bronze.

Pedestal (Primer Housing)

The pedestal is constructed of anodized aluminum for both aluminum and bronze pumps and supports the piston primers and main bearings.

Discharge Manifold

The discharge manifold is constructed of corrosion-resistant anodized aluminum or bronze.

Discharge Valves (Low Pressure)

The low pressure discharge valves are a non-return valve constructed of anodized aluminum or bronze.

High Pressure Control Valve

The high pressure control valve engages the high pressure stage allowing high pressure water to the hose reel.

Mechanical Seal

The mechanical seal consists of a flat, highly polished (lapped), self-adjusting (spring-fed) carbon ring that is sealed in the pump body. The carbon ring presses against a highly-polished rotating ring that is sealed to and rotates with the impeller.

High Pressure Relief Valve

The high pressure relief valve is designed to open as the pressure increases in the high pressure side of the pump and discharges the high pressure water into the low pressure side of the pump to prevent sudden surges.

Automatic Piston Primer

The pump is equipped with two automatic piston primer. For best performance, operate primers at 2300-2600 rpm (impeller speed). The primers will still perform at lower speeds, however, the priming time will increase.

High Pressure Inlet Strainer

The high pressure inlet strainer traps particles in the water before entering the high pressure stage.

Thermal Relief Valve

The thermal relief valve opens as the temperature of the water inside the pump reaches 490 C. The valve opens and diverts water to one of the following locations:

To the holding tank, vehicle tank or to atmosphere (ground).

Tachometer Connection

A magnetic pick-up feeds the pump shaft revolutions to a tachometer which displays the pump impeller speed in revolutions per minute.

Lubrication

Provisions are provided to check and fill required lubricants in the pedestal (primer housing) and K Series Transmissions (if so equipped). See Pages 15-16 for locations of lubrication fills and drains.

Pump Drain

The pump is provided with a 3/4 NPT water drain. The drain should be fitted with piping, valve and routed to suitable draining location.

K Series Transmission

(Models HL200K, HL300K & HL400K only)

Consists of a cast iron case with steel shafts and helical gears. Increases the impeller speed of the pump by stepping up the input shaft speed. Available in three input shaft mounting positions, vertical, left or right.

Components

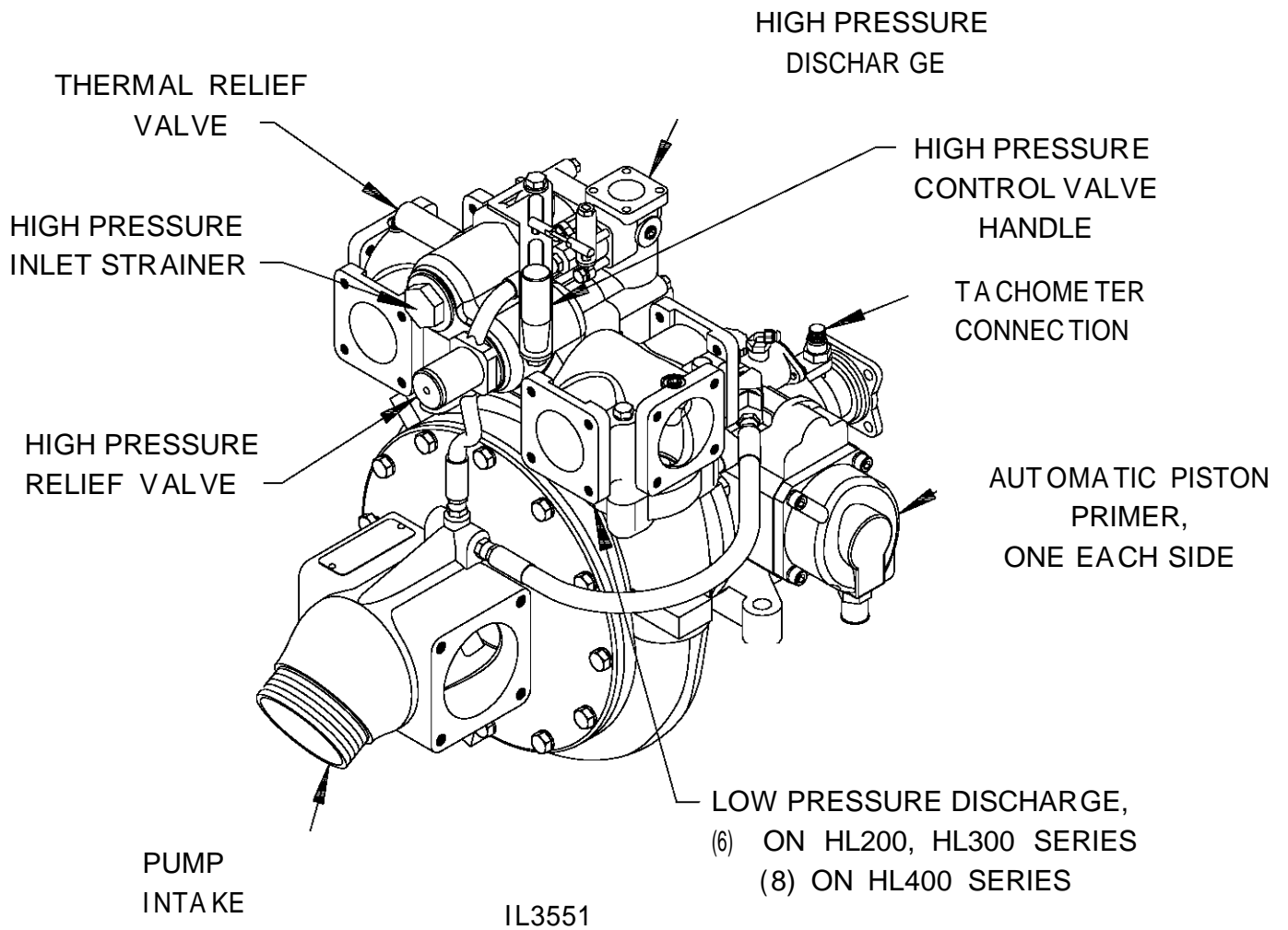

Operating Instructions

The HL series pump can be used to pump high volume of water at low pressure, low volumes at high pressure or low and high pressure simultaneously.

Low Pressure Mode

In the low pressure mode, the control valve is set to low pressure setting (handle to the left). Water flows from the low pressure impeller out through the manifold main discharges

The high pressure impeller does not pump any water, however, a small flow of water is passed through the high pressure impeller and back into the pump intake to lubricate and cool the high pressure impeller.

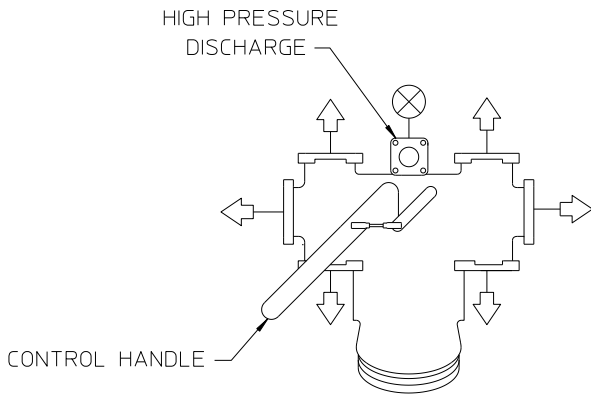

IL 3552

High Pressure Mode

In the high pressure mode, the control valve is set to the high pressure setting (handle to the right). Water flows from the low pressure impeller out through the manifold main discharges and also into the high pressure impeller.

The water from the high pressure impeller is discharged from the main manifold high pressure discharge.

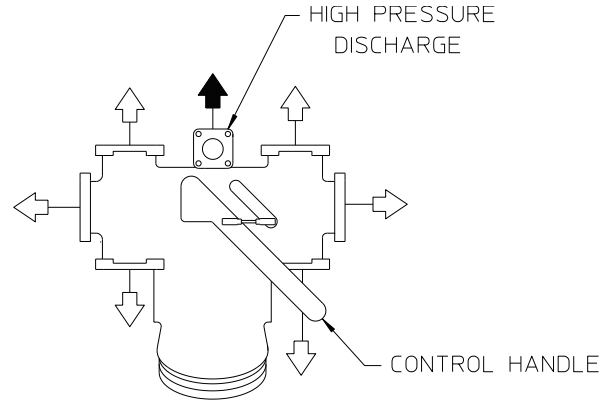

IL 3552

Key	
⇨	Low Pressure Water
➡	High Pressure Water
⊗	No Flow

NOTICE

The control valve handle must either be in the full low pressure (left) or high pressure (right) position.
Never operate the pump with the control valve partially between the two operating modes.

Pumping from Hydrant or in Relay

WARNING

Pressure Hazard. May result in personal injury.

Prior to connection or removal of hoses, caps or other closures with pump intake or pump discharge connections, relieve pressure by opening drains or bleeder valves. Bleeder valves should also be used while filling a hose connected to an intake with water.

WARNING

Scalding Water Hazard. May result in serious burns.

When operating the pump, be sure to open at least one discharge valve slightly to prevent the pump from overheating. If the pump runs for a few minutes completely closed, it may heat the water enough to scald someone when the valve is opened. Overheating can damage the packing, seals and other pump parts. If the apparatus builder has installed a bypass system or other provision designed to prevent overheating, opening a discharge valve may be unnecessary.

1. Open intake, hydrant and other valves as necessary to allow water to enter the pump.
2. Allow about 30 seconds for water to flow into pump.
3. Engage pump drive in accordance to with the vehicle operation instructions and accelerate engine to obtain desired discharge pressure and capacity.

NOTICE

This pump has a mechanical seal, limit intake pressure to 75 psi (5 bar) if possible. Although the pump will operate properly with higher intake pressure, such operation will greatly accelerate mechanical seal wear.

NOTE: The HL pump has an automatic priming system that will engage or disengage when the discharge pressure rises above or falls below a predetermined setting.

4. Open discharge valves and accelerate engine to obtain desired discharge pressure and capacity.

NOTICE

Do not attempt to pump more water than is available from the hydrant or relaying pumper. Always make sure the intake pressure compound-gage reading stays above zero. Some fire departments operate at a minimum intake pressure of 15 psi (1 bar) when pumping from hydrant or in relay to prevent a "soft" intake hose from collapsing.

5. Set low pressure relief valve or other governing device to desired pressure (relief valve or governing device not supplied by Waterous).

After Pumping

1. If pumping anything but clean water, remove all intake and discharge caps, open all valves and open all drains. Flush entire system with clean, fresh water for several minutes to remove all traces of impurities.
2. Cycle the piston primers. Operate them until all the fluid is discharged from the piston primer discharge pipes.

NOTICE

Freezing water hazard. May cause damage to the pump.

If the pump is exposed to freezing temperatures, drain all water from pump, lines and accessories.

3. If pump is kept full of water when not in use, make sure water is clean and non-corrosive. Make sure the pump is completely full or completely drained (never partially full).
4. Disengage pump drive in accordance with the vehicle operation instructions.
5. Close all drains and install intake and discharge caps.

Pumping from Water Tank

WARNING

Pressure Hazard. May result in personal injury.

Prior to connection or removal of hoses, caps or other closures with pump intake or pump discharge connections, relieve pressure by opening drains or bleeder valves. Bleeder valves should also be used while filling a hose connected to an intake with water.

WARNING

Scalding Water Hazard. May result in serious burns.

When operating the pump, be sure to open at least one discharge valve slightly to prevent the pump from overheating. If the pump runs for a few minutes completely closed, it may heat the water enough to scald someone when the valve is opened. Overheating can damage the packing, seals and other pump parts. If the apparatus builder has installed a bypass system or other provision designed to prevent overheating, opening a discharge valve may be unnecessary.

1. Open valve(s) in piping between water tank and pump intake and at least one discharge valve.
2. Allow about 30 seconds for water to flow into pump.

NOTE: The HL pump has an automatic priming system that will engage or disengage when the discharge pressure rises above or falls below a predetermined setting.

3. Engage pump drive in accordance to with the vehicle operation instructions and accelerate engine to obtain desired discharge pressure and capacity.

NOTICE

Do not attempt to pump more water than is available from the water tank. Always make sure the intake pressure compound gage reading stays above zero.

4. Set low pressure relief valve or other governing device to desired pressure (relief valve or governing device not supplied by Waterous).

After Pumping

1. If pumping anything but clean water, remove all intake and discharge caps, open all valves and open all drains. Flush entire system with clean, fresh water for several minutes to remove all traces of impurities.
2. Cycle the piston primers. Operate them until all the fluid is discharged from the piston primer discharge pipes.

NOTICE

Freezing water hazard. May cause damage to the pump.

If the pump is exposed to freezing temperatures, drain all water from pump, lines and accessories.

3. If pump is kept full of water when not in use, make sure water is clean and non-corrosive. Make sure the pump is completely full or completely drained - never partially full.
4. Disengage pump drive in accordance with the vehicle operation instructions.
5. Close all drains and install intake and discharge caps.

Pumping from Draft

WARNING

Pressure Hazard. May result in personal injury.

Prior to connection or removal of hoses, caps or other closures with pump intake or pump discharge connections, relieve pressure by opening drains or bleeder valves. Bleeder valves should also be used while filling a hose connected to an intake with water.

WARNING

Scalding Water Hazard. May result in serious burns.

When operating the pump, be sure to open at least one discharge valve slightly to prevent the pump from overheating. If the pump runs for a few minutes completely closed, it may heat the water enough to scald someone when the valve is opened. Overheating can damage the packing, seals and other pump parts. If the apparatus builder has installed a bypass system or other provision designed to prevent overheating, opening a discharge valve may be unnecessary.

NOTE: To get full capacity, quick prime and maintain pump efficiency:

- a. Position vehicle as near as possible to water supply.
- b. Avoid humps and sharp bends in intake hose. Make sure no part of hose is higher than pump inlet. (Air pockets in intake hose may cause loss of prime or erratic pump action, and may reduce pump capacity.)
- c. Make sure all intake connections are tight and discharge valves are closed.
- d. Immerse intake strainer at least two feet below water surface to prevent pump from drawing air. (Whirlpools forming above intake strainer indicate that strainer is too close to surface of water.)
- e. Make sure intake strainer is far enough from bottom to prevent sand, gravel and other foreign matter from being drawn into the pump.
6. Open intake and other valves as necessary to allow water to enter the pump.
7. Engage pump drive in accordance to with the vehicle operation instructions and accelerate engine to obtain desired discharge pressure and capacity.

NOTE: The HL pump has an automatic priming system that will engage or disengage when the discharge pressure rises above or falls below a predetermined setting.

8. Open discharge valves, and accelerate engine to obtain desired discharge pressure and capacity.
9. Set low pressure relief valve or other governing device to desired pressure (relief valve or governing device not supplied by Waterous).

After Pumping

1. If pumping anything but clean water, remove all intake and discharge caps, open all valves and open all drains. Flush entire system with clean, fresh water for several minutes to remove all traces of impurities.
2. Cycle the piston primers. Operate them until all the fluid is discharged from the piston primer discharge pipes.

NOTICE

Freezing water hazard. May cause damage to the pump.

If the pump is exposed to freezing temperatures, drain all water from pump, lines and accessories.

3. If pump is kept full of water when not in use, make sure water is clean and non-corrosive. Make sure the pump is completely full or completely drained (never partially full).
4. Disengage pump drive in accordance with the vehicle operation instructions.
5. Close all drains and install intake and discharge caps.

RTP Foam System

Operation Requirements

Pump Intake:

The foam systems will function properly when pumping from tank or draft. When pumping from a pressurized source such as a hydrant or relay, pump intake pressure must be limited. High intake pressure will cause back pressure on the foam eductor and decrease foam flow.

Operating Instructions

To Start Foam:

1. Operate pump at 8 bar (116 psi) minimum discharge pressure.
2. Open the valve that directs discharge flow to the foam eductor.
3. Estimate pump discharge flow. Refer to table on foam proportioner control panel and select the setting number based on the pump discharge flow and foam concentrate available (1, 3 or 6%).
4. Turn the proportioner control to the appropriate setting number from the table.

NOTICE

All Pump discharges will have the ability to discharge foam.

Pump Discharge:

Pump discharge pressure must be 8 bar (116 psi) minimum. Foam flow will decrease at lower discharge pressure and the proportioner will no longer be accurate.

To Stop Foam:

1. Turn the proportioner control to "OFF".
2. Continue to operate the pump and flow clean water out all discharges for a minimum of two (2) minutes to rinse foam solution from pump, lines and valves.

NOTICE

All discharges must be flushed with clean water after operation even if they were not used. The foam system distributes foam solution to all interior surfaces of the pump and valves. Pump corrosion and stuck valves may result if the pump is not flushed with clean water after foam use.

3. Close valve that directs pump discharge flow to the eductor.

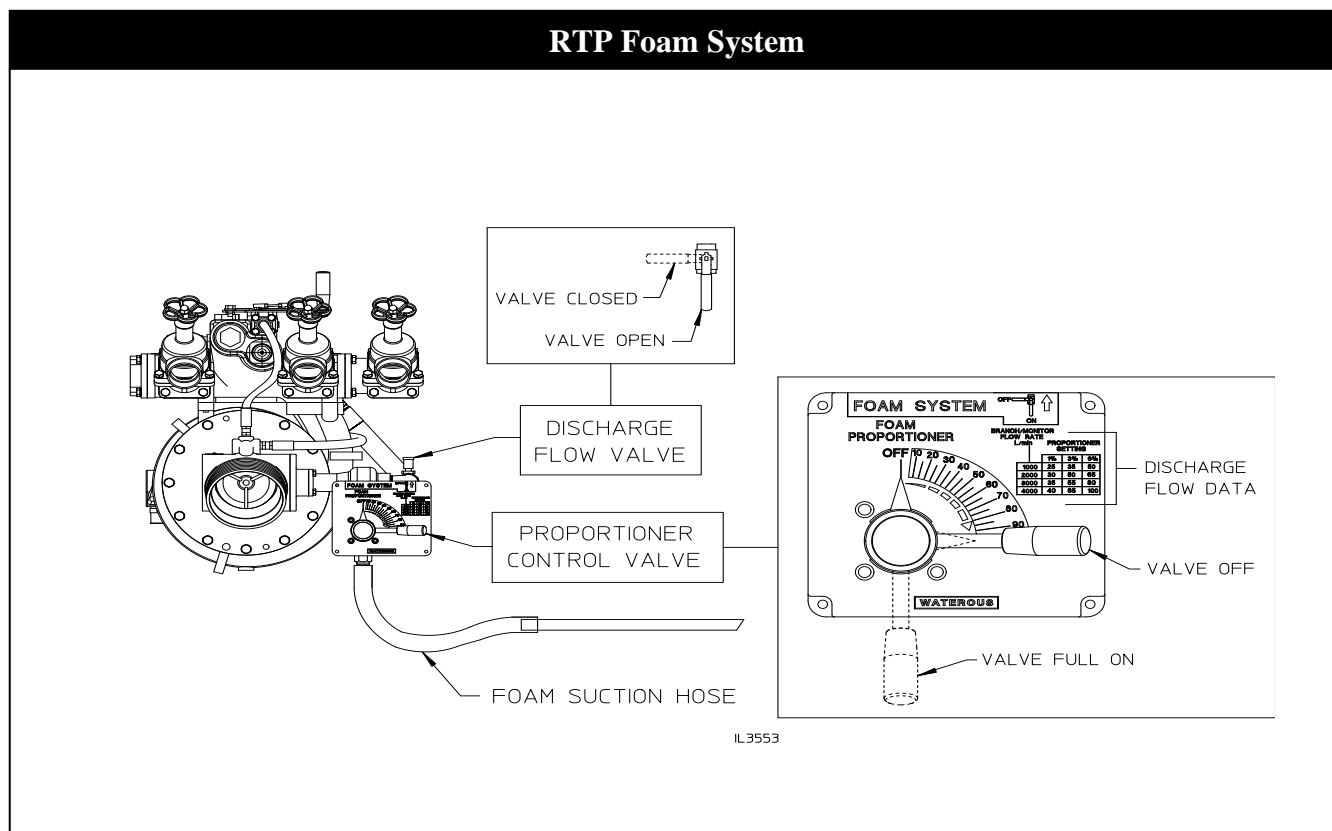

Control Panel

Panel Components

1. **High Pressure Stage Inlet Strainer** location behind the panel.
2. **Low Pressure Operation Mode Indicator** (control handle to the left).
3. **Pump Engaged Light**: Once the pump is engaged, indicator will light.
4. **Tachometer / Hourmeter**: Indicates pump speed in revolutions per minute and the number of hours the pump has been in operation.
5. **Pump Overheat Indicator**: if the pump water temperature reaches 49° C, indicator will light.
6. **Intake Gauge**: Indicates pressure of water entering the pump.
7. **Main Pump Pressure Discharge Gauge**: Indicates pressure of water being discharged from main pump discharges.
8. **High Pump Pressure Discharge Gauge**: Indicates pressure of water being discharged from high pressure pump discharge.
9. **Optional Tank Gauges**:
 - a. Water Tank Gauge: Indicates the level of the water tank.
 - b. Foam Tank Gauge: Indicates the level of the foam tank.
10. **High Pressure Operation Mode Indicator** (control handle to the right).

Control Panel

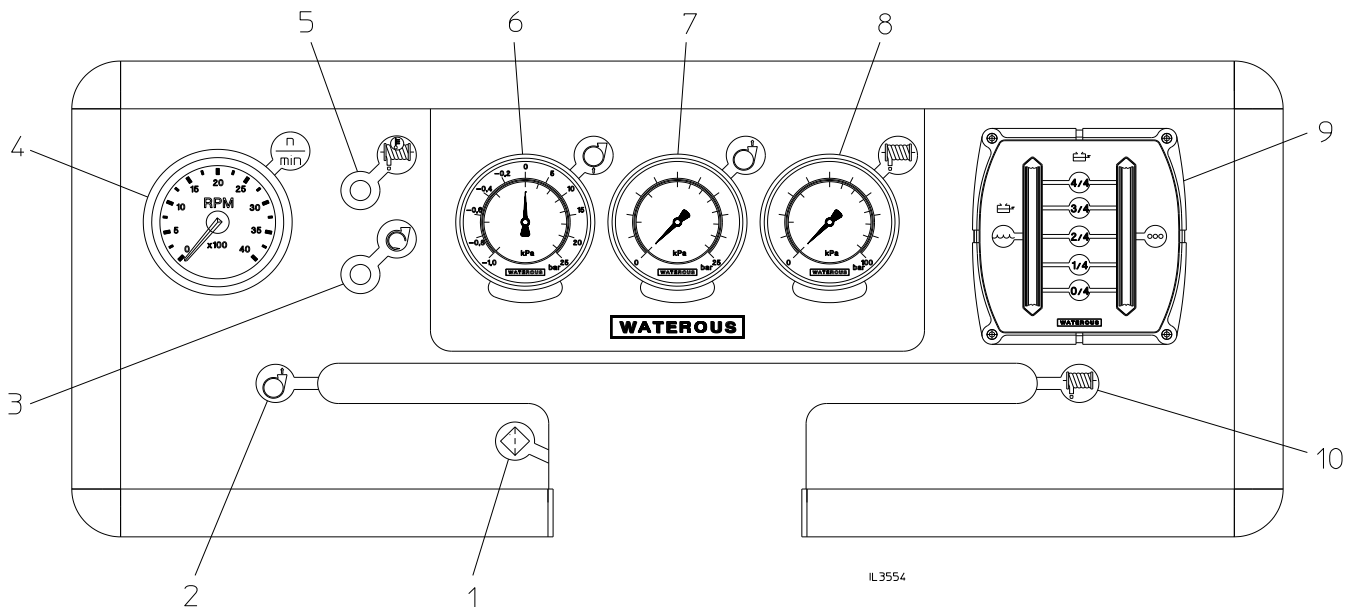

Fire Hose Testing



WARNING

Hose Testing Hazard. May result in serious personal injury.

Due to a potential for catastrophic hose failure during service testing of fire hose, it is vital that safety precautions be taken to prevent exposure of anyone to this danger. Fire pumps on fire department apparatus are not designed for and should not be used for service testing of fire hoses. Hose testing machines should be used for service testing of fire hoses.

NFPA 1962 *Standard for the Inspection, Care, and use of Fire Hose, Couplings, and Nozzles and the Service Testing of Fire Hose* provides requirements and testing procedures for service-testing fire hose at least annually. NFPA 1962 includes procedures for service testing with either a hose testing machine or with a pump on a fire department fire apparatus.



WARNING

Pressure Hazard. May result in serious personal injury.

If a fire pump on a fire department apparatus is used for service testing of fire hoses, the procedures in NFPA 1962 **MUST be followed** including the use of a fire department gate valve with a ¼-inch (6 mm) hole drilled through the gate installed between the fire apparatus discharge outlet and the hose test layout to prevent a volume surge from the pump in the event a hose bursts during testing.

During fire hose testing with a fire pump on a fire department fire apparatus, the fire pump is required to be operated at high discharge pressure with little or no flow out of the apparatus.



WARNING

Scalding Water Hazard. May result in serious burns.

If a fire pump on a fire department apparatus is used for service testing of fire hoses, pump discharge water must be circulated through a by-pass system or discharged through a slightly open discharge valve, or some other provision must be used to prevent overheating. If the pump runs for a few minutes without adequate flow through the pump, water may be heated enough to scald someone when a valve is opened.

CAUTION

If a fire pump on a fire department apparatus is used for service testing of fire hoses, operating the pump at high discharge pressure with little or no flow may result in severe damage to the pump.

Maintenance

NOTICE

All pump maintenance can be performed using standard tools.

Service Parts

NOTICE

Use only Waterous approved parts. Service parts lists showing all repair parts are included in the manual furnished with each pump.

Refer to the following Service Parts Lists:

Component	Pump Model					
	HL200 Series		HL300 Series		HL400 Series	
	HL200D	HL200K	HL300D	HL300K	HL400D	HL400K
Pump	SPL83161		SPL83161		SPL83155	
Auxiliary Intake and Discharge Fittings	SPL83156		SPL83156		SPL83156	
Optional RTP Foam System	SPL83157		SPL83157		SPL83157	
Optional Control Panel	SPL83158		SPL83158		SPL83158	
K Series Transmission	-	SPL83160	-	SPL83160	-	SPL83160

Mechanical Seal

NOTICE

The pump shaft is sealed with a mechanical seal and no adjustment is required. When the pump is in operation, the water being pumped lubricates and cools the seal. If the seal leaks, replace the entire seal.

NOTICE

Prolonged dry pump operation or operating a dry pump at high speeds will reduce the life of the mechanical seal.

High Pressure Inlet Strainer

NOTICE

The high pressure inlet strainer is partially self-flushing, however, it occasionally needs to be removed and flushed. Check the strainer weekly and clean as required.

High Pressure Inlet Strainer

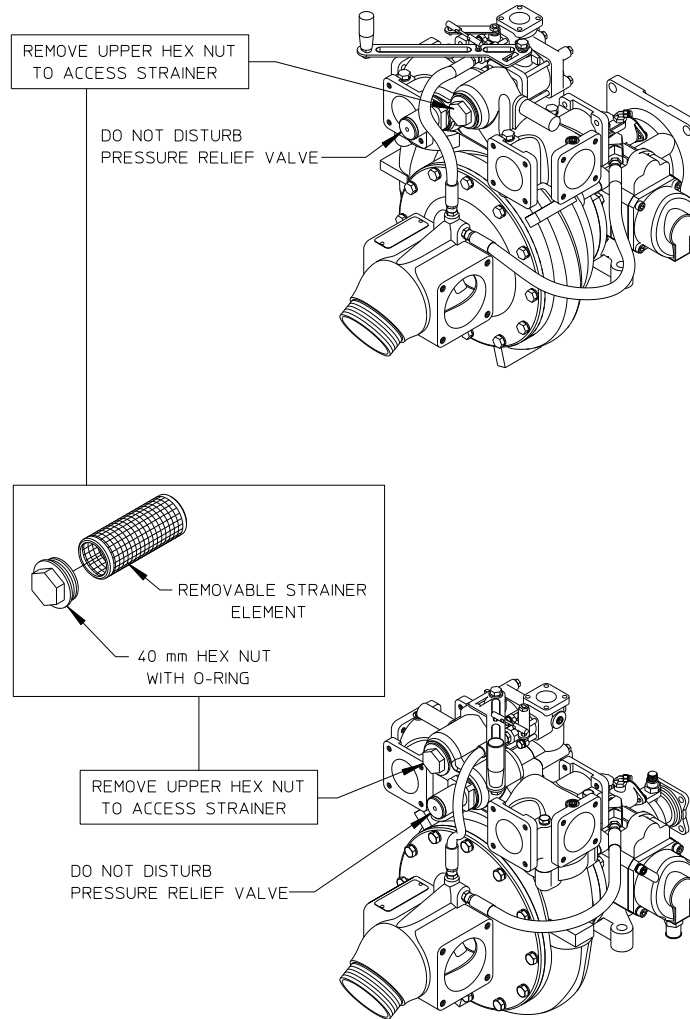

IL3555

Note that the location of strainer varies based on pump impeller rotation as depicted in the two pump views.

Lubrication

NOTICE

1. Check lubrication levels once a month and change annually.
2. Capacities shown are approximate. Quantities listed vary based on ratio and /or mounting orientation.
3. Always fill to the marking on dipstick (pedestal) or bottom of the plug labeled "Oil Level" (K Series Transmission).
4. K Transmission breather may be removed and the hole used as the lubricant fill.
5. Synthetic oil substitutes are acceptable.

Models HL200D, HL300D and HL400D

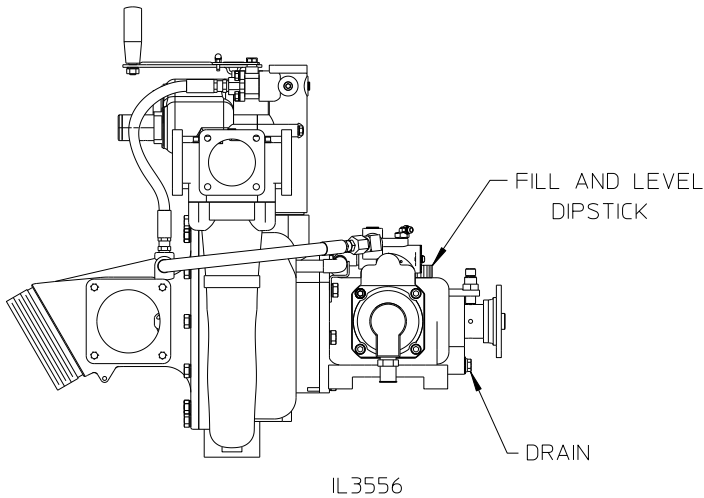

Models HL200D and HL300D

Pedestal (Primer Housing)

Lubricant	Quantity
SAE 10W-30 Motor Oil	.95 L (1 Quart)

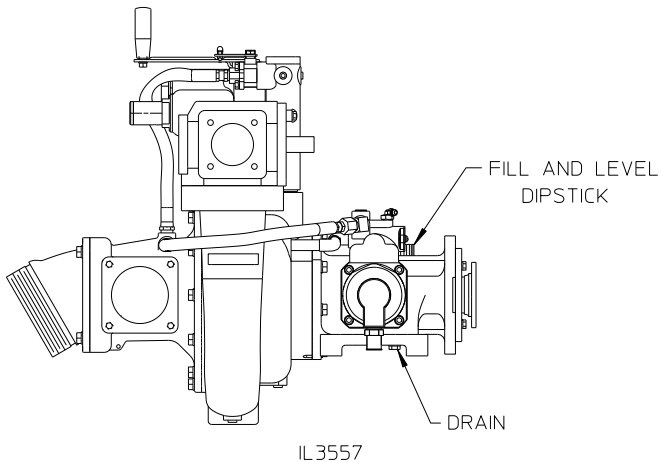

Model HL400D

Lubrication Continued

Models HL200K, HL300K and HL400K

Lubrication required for Pedestal (Primer Housing) and K Series Transmission

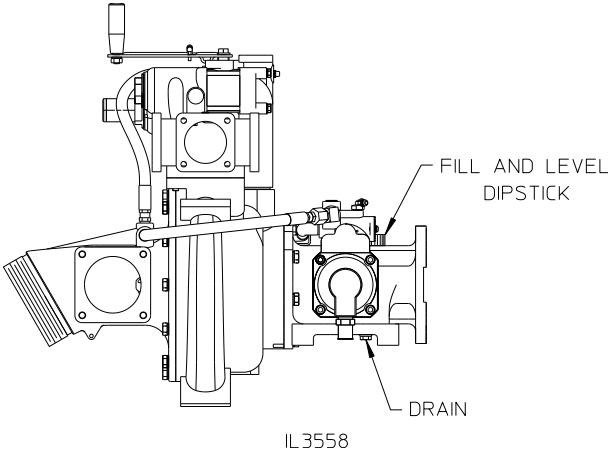

Pedestal (Primer Housing)	
Lubricant	Quantity
SAE 10W-30 Motor Oil	.95 L (1 Quart)

K Series Transmission	
Lubricant	Quantity
SAE 80W-90 Gear Oil	.95 L (1 Quart)

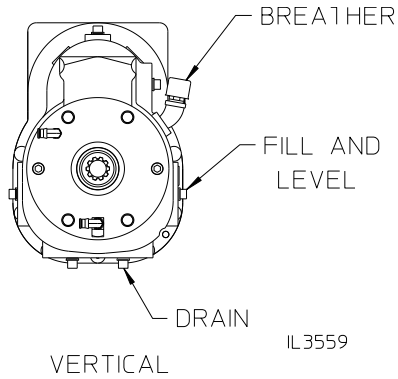
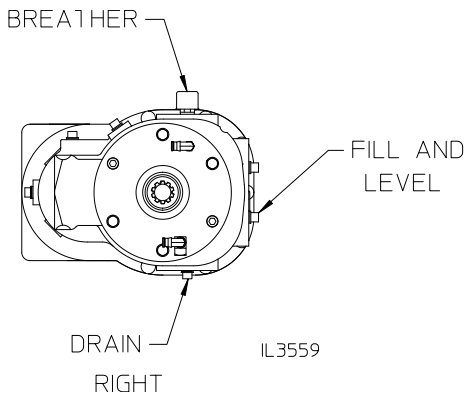
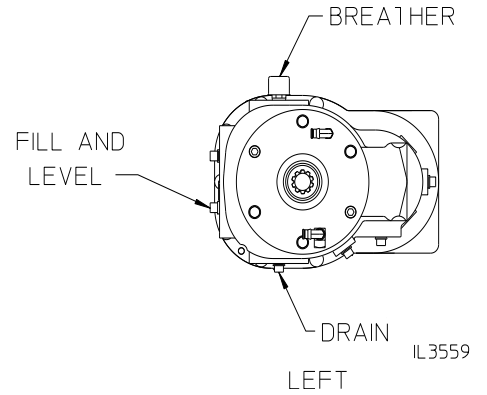

Testing

NOTICE

An annual test should be performed to check pump performance. This will reveal the condition of the internal components and if any repairs are required.