

Butterfly Valves

Index:

Valve Operator		Ground Wire	Operation	Handle Installation	Panel Installation
Electric Actuator		2	3	--	4
Manual Actuator	Indicating	5	6	7	--
	Non-Indicating	--	9	10	--
Pneumatic Actuator		--	See Metso Website MOD D Actuator	--	--
Troubleshooting		12			

Refer to the following for Repair Parts:

Valve Operator	Actuator	Valve		
		From Waterous	From Valve Manufacturer	
Electric Actuator	SPL82743 (6 in. Valve) SPL82966 (8 in. Valve)	SPL82743 (6 in. Valve) SPL82966 (8 in. Valve)	See Metso Website Series 815W Jamesbury Valve	
Manual Actuator				Indicating
				Non-Indicating
Pneumatic Actuator	See Metso Website MOD D Actuator	-		

NOTE: Instructions subject to change without notice.

Electric Actuator – Ground Wire

Connect 18 AWG ground wire (5 foot length furnished) to the apparatus chassis which will ensure a proper ground for the valve rotary encoder.

GROUND WIRE,
CONNECT TO
APPARATUS CHASSIS

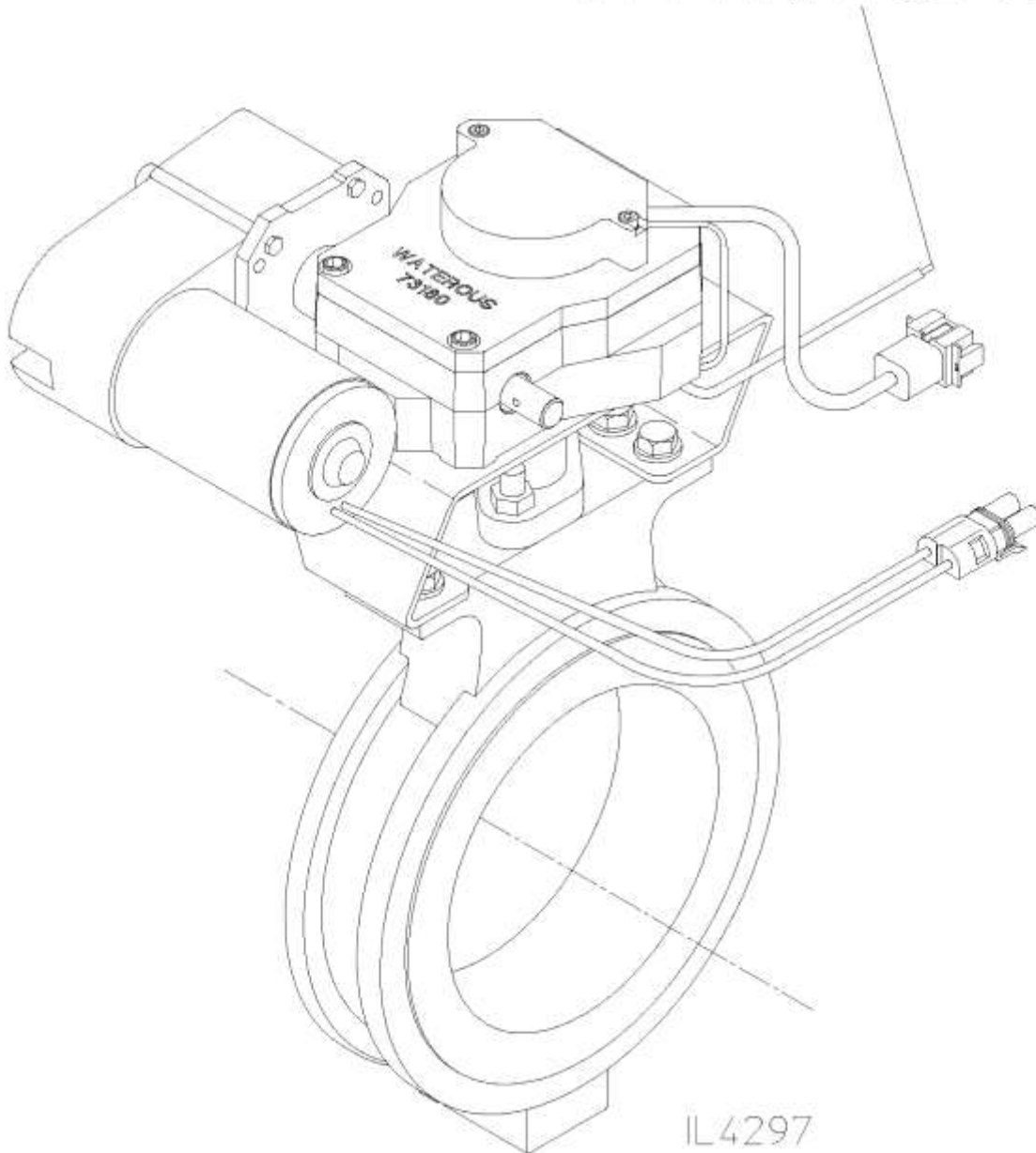

Electric Actuator – Operation Manual Override

Valve may be manually overridden two ways:
 Behind the panel via a hex adapter.
 From the panel via a knob.

The valve actuator override stem is positioned at the factory for override operation from the panel where the intake is located.

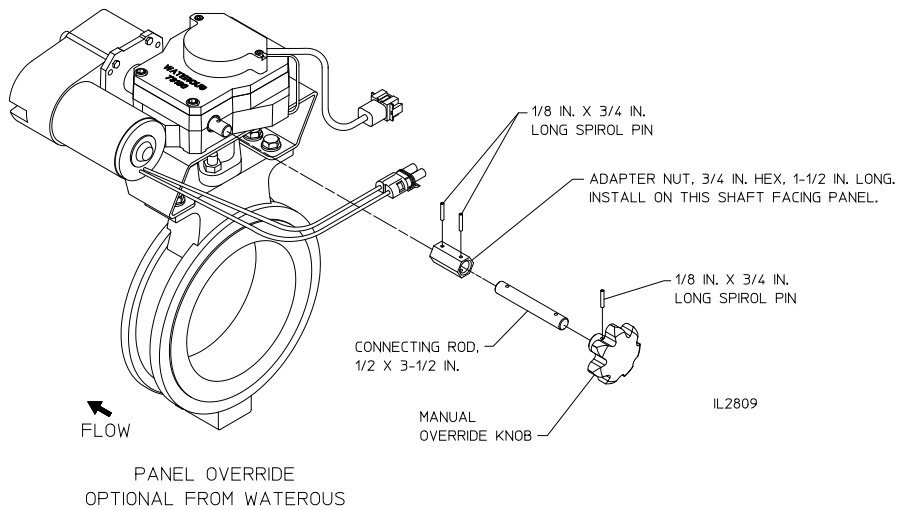
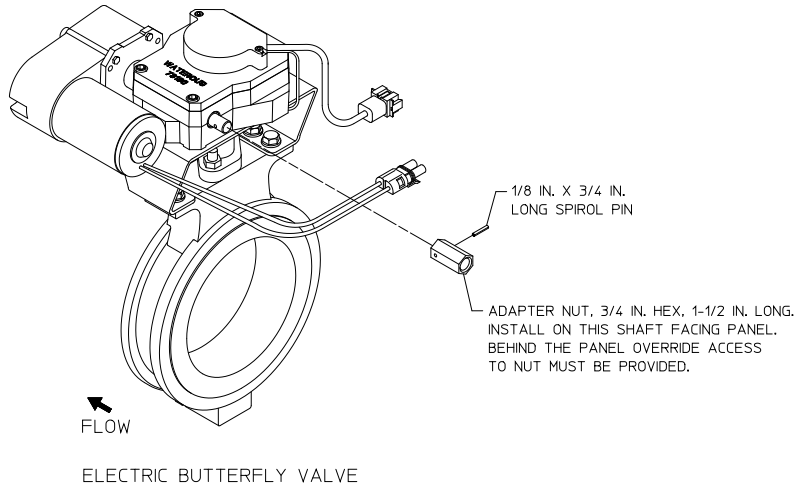

Panel Override Optional from Waterous

Electric Actuator - Panel Installation

Figure 1. Panel Wiring Installation

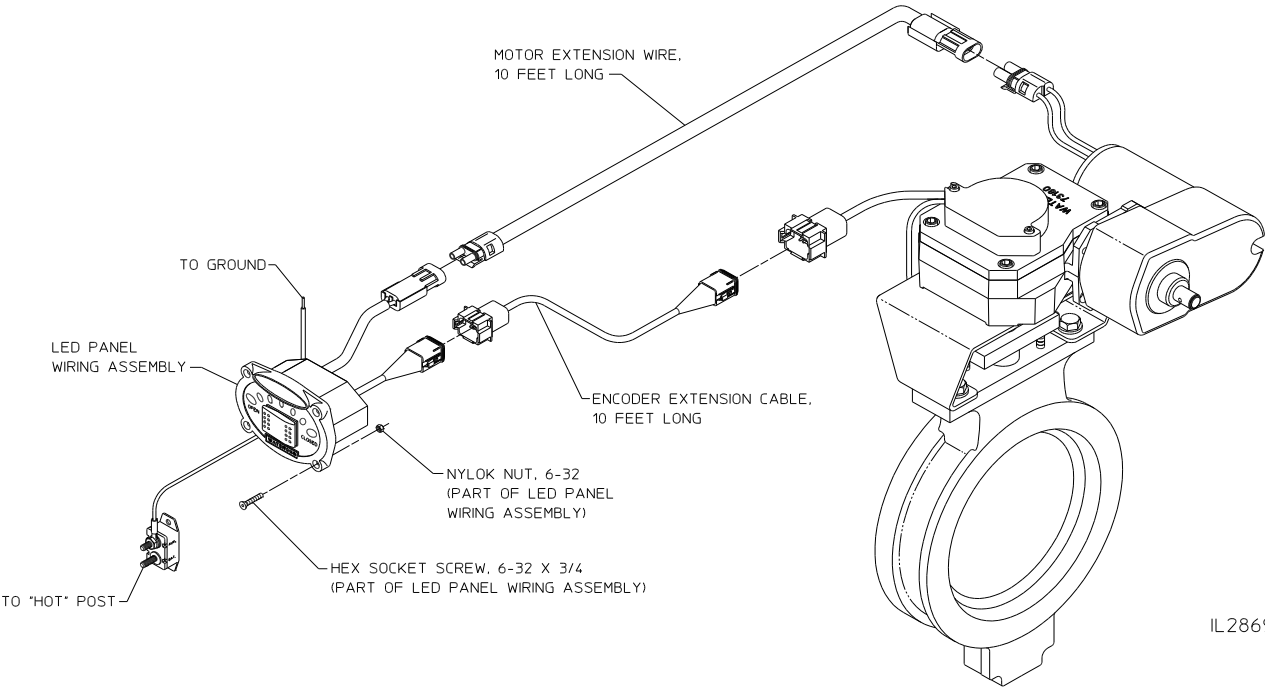

IL2869

Figure 2. Panel Hole Layout

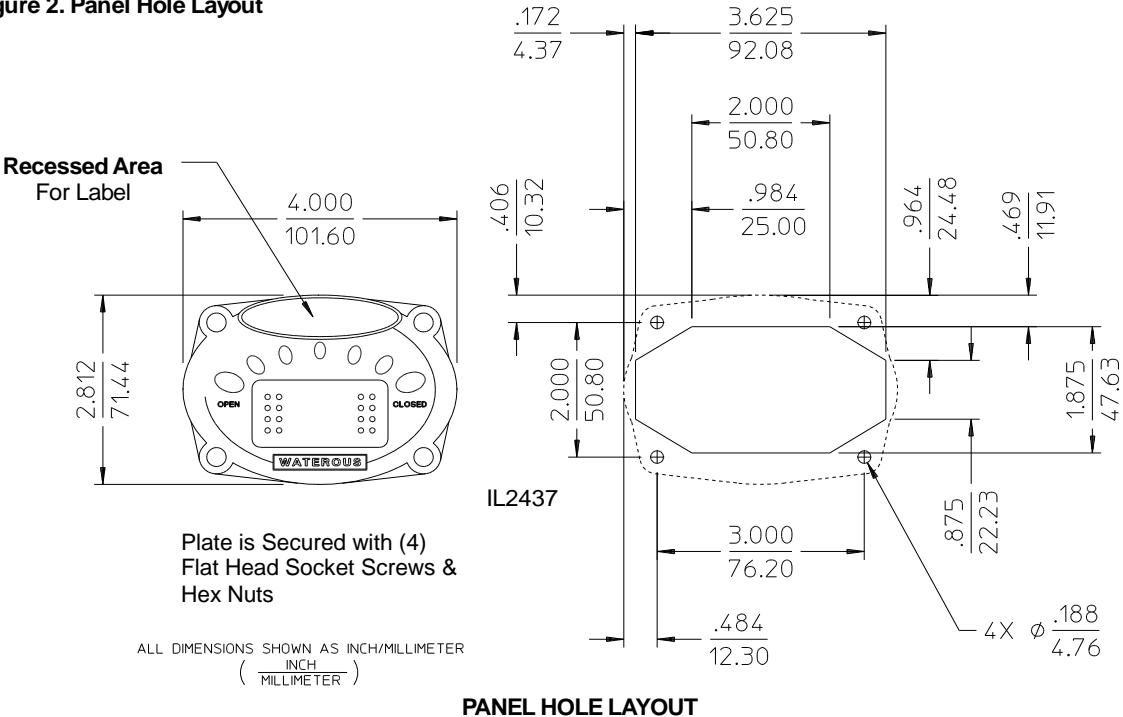

Manual Actuator – Indicating Ground Wire

Connect 18 AWG ground wire (5 foot length furnished) to the apparatus chassis which will ensure a proper ground for the valve rotary encoder.

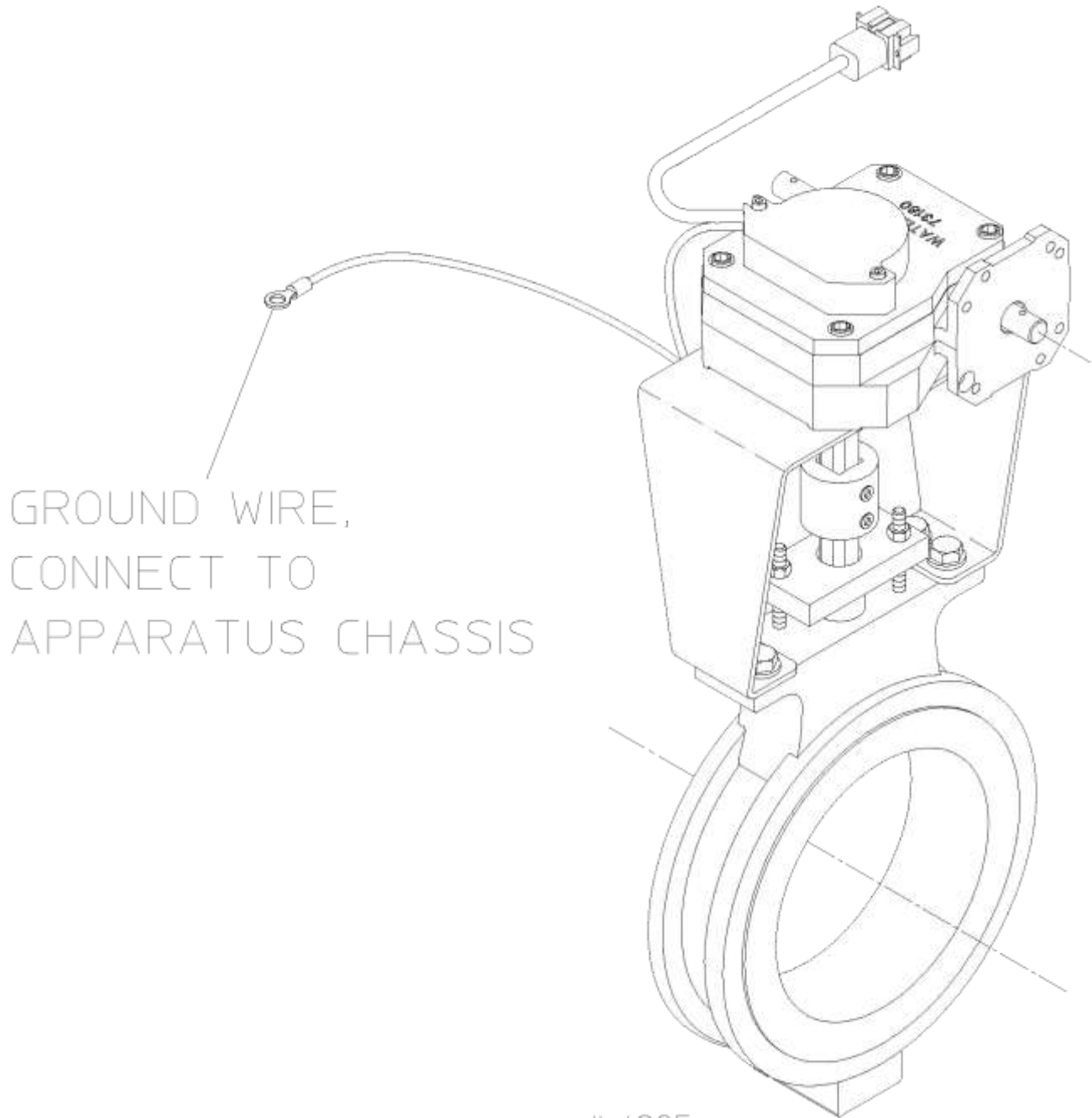

Manual Actuator – Indicating Operation

The actuator shaft is positioned at the factory for operation of the valve from the panel where the intake is located, the handle rotates CCW to open.

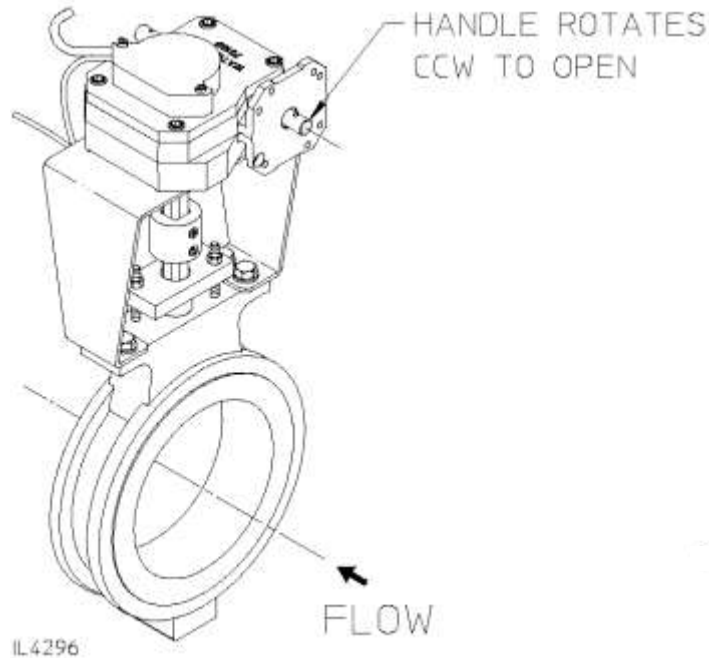

If the valve is to be operated from the panel on opposite side of the vehicle, the handle can be connected in one of two ways:

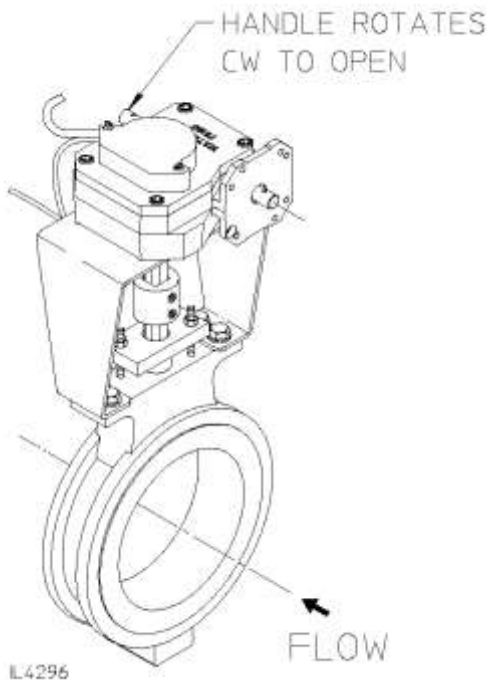

Connect handle to shaft on opposite side of the actuator. The handle will rotate CW to open valves with this modification.

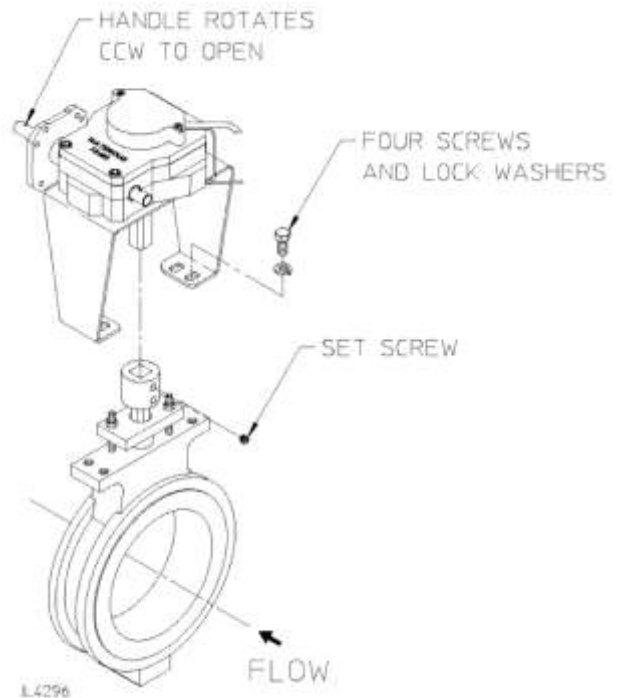

Place the valve in the closed position. Rotate the valve actuator 180° per detail above. The handle will rotate CCW to open valves with this modification.

Manual Actuator - Indicating Handle Installation

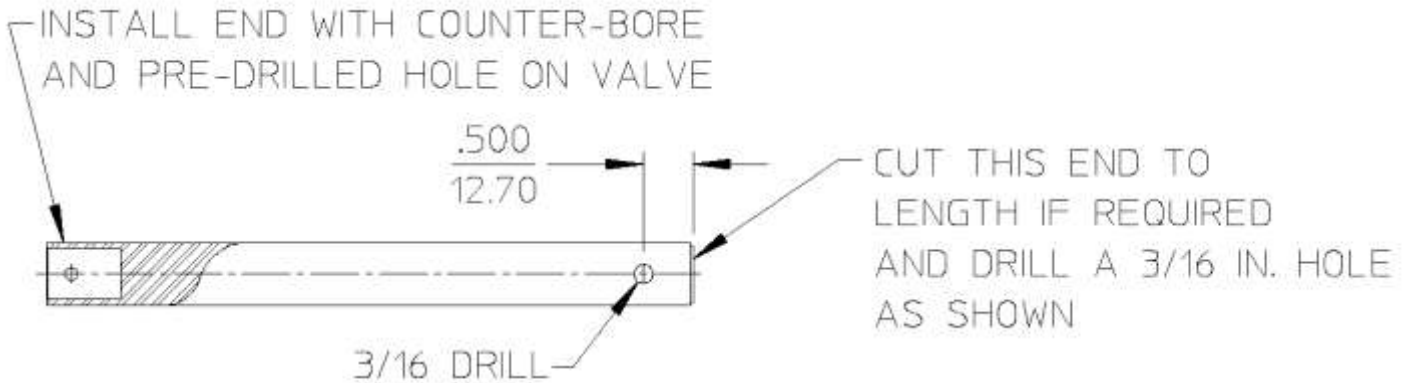
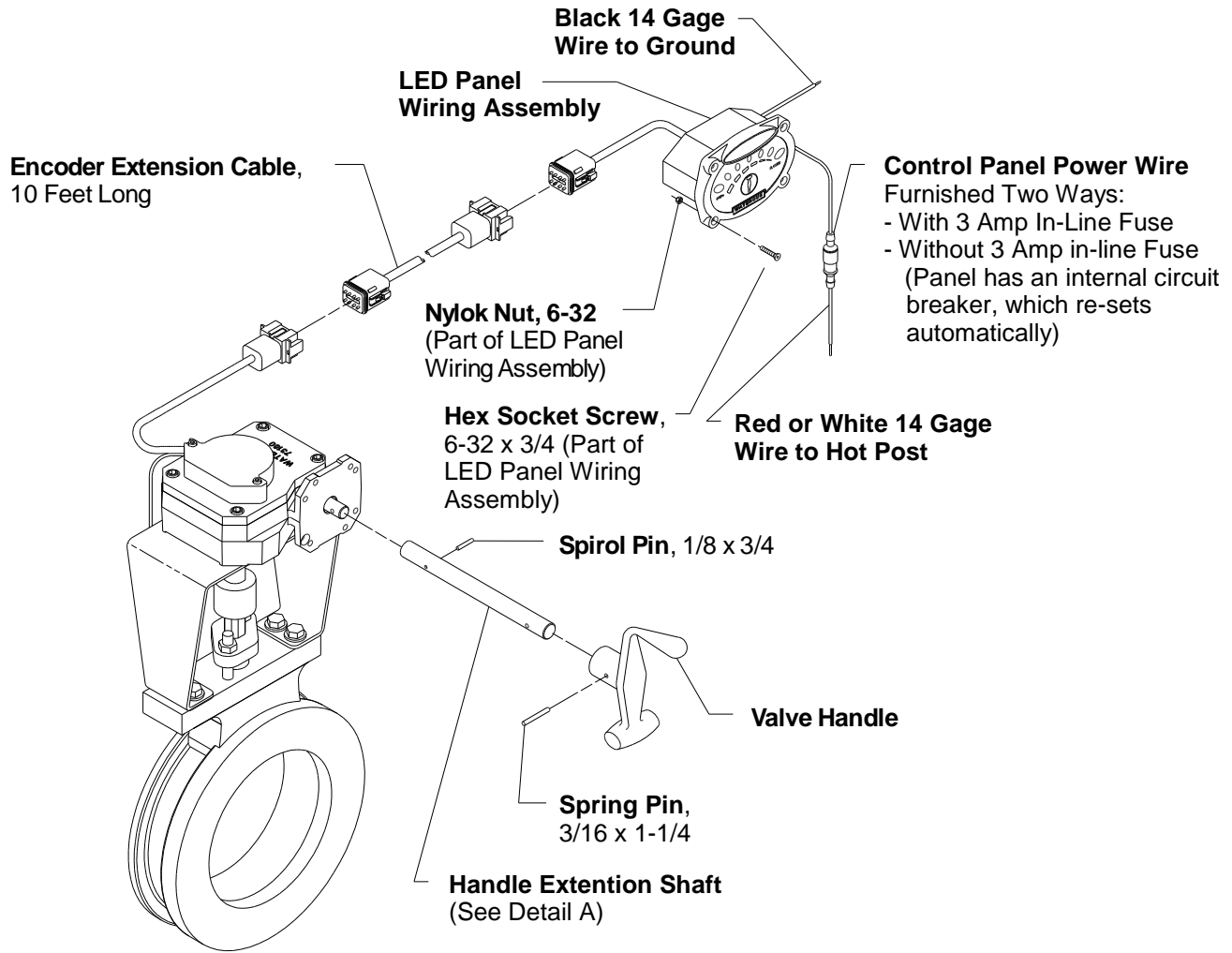

DETAIL A
HANDLE EXTENSION SHAFT

IL2874

Manual Actuator – Indicating Panel Installation

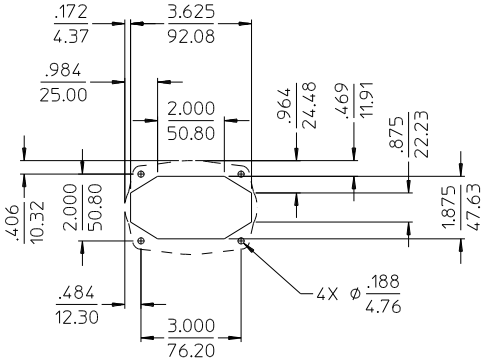
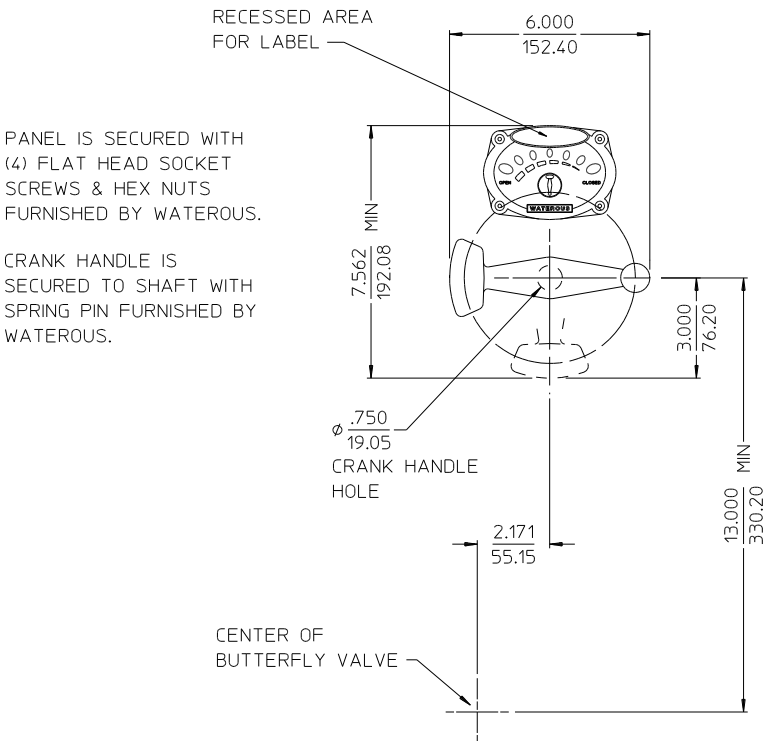

PANEL HOLE LAYOUT

IL2875

ALL DIMENSIONS SHOWN
AS INCH/MILLIMETER
(INCH / MILLIMETER)

Manual Actuator - Non-Indicating Operation

The valve stem is positioned at the factory for operation of the valve from the panel where the intake is located, the handle rotates CCW to open.

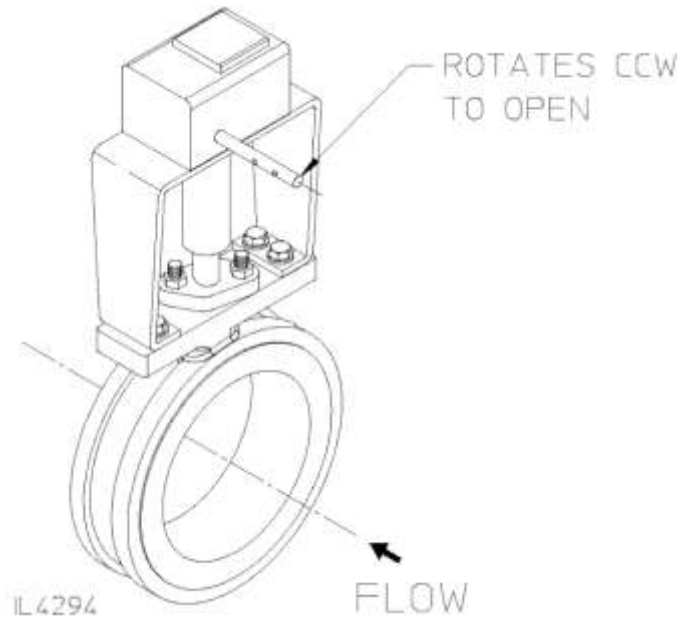

If the valve is to be operated from the panel on the opposite side of the vehicle, rotate the valve actuator 180° per the drawing below. The handle will rotate CCW to open valves with this modification.

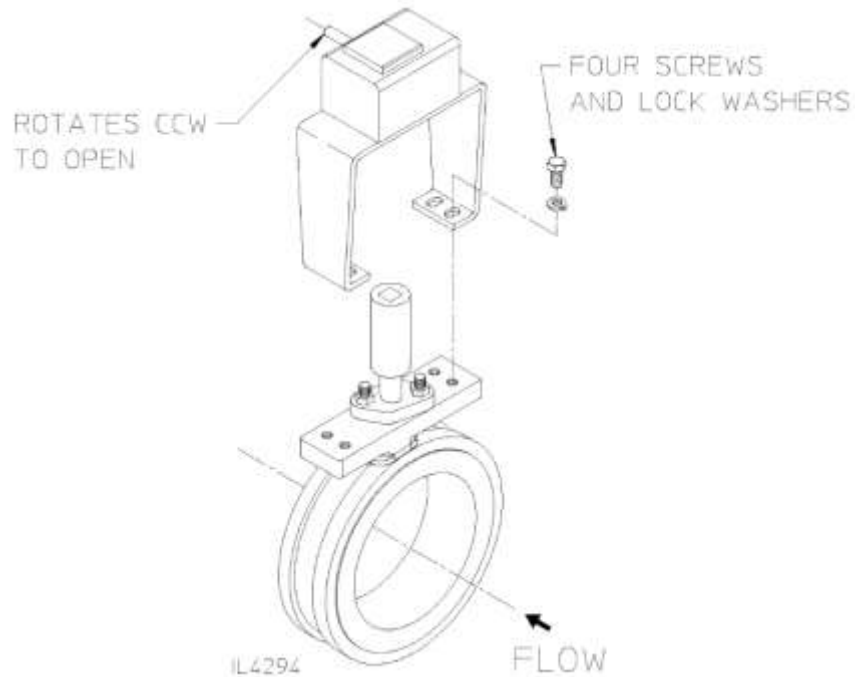

Note: Valve must be in the CLOSED position

Manual Actuator - Non-Indicating Handle Installation

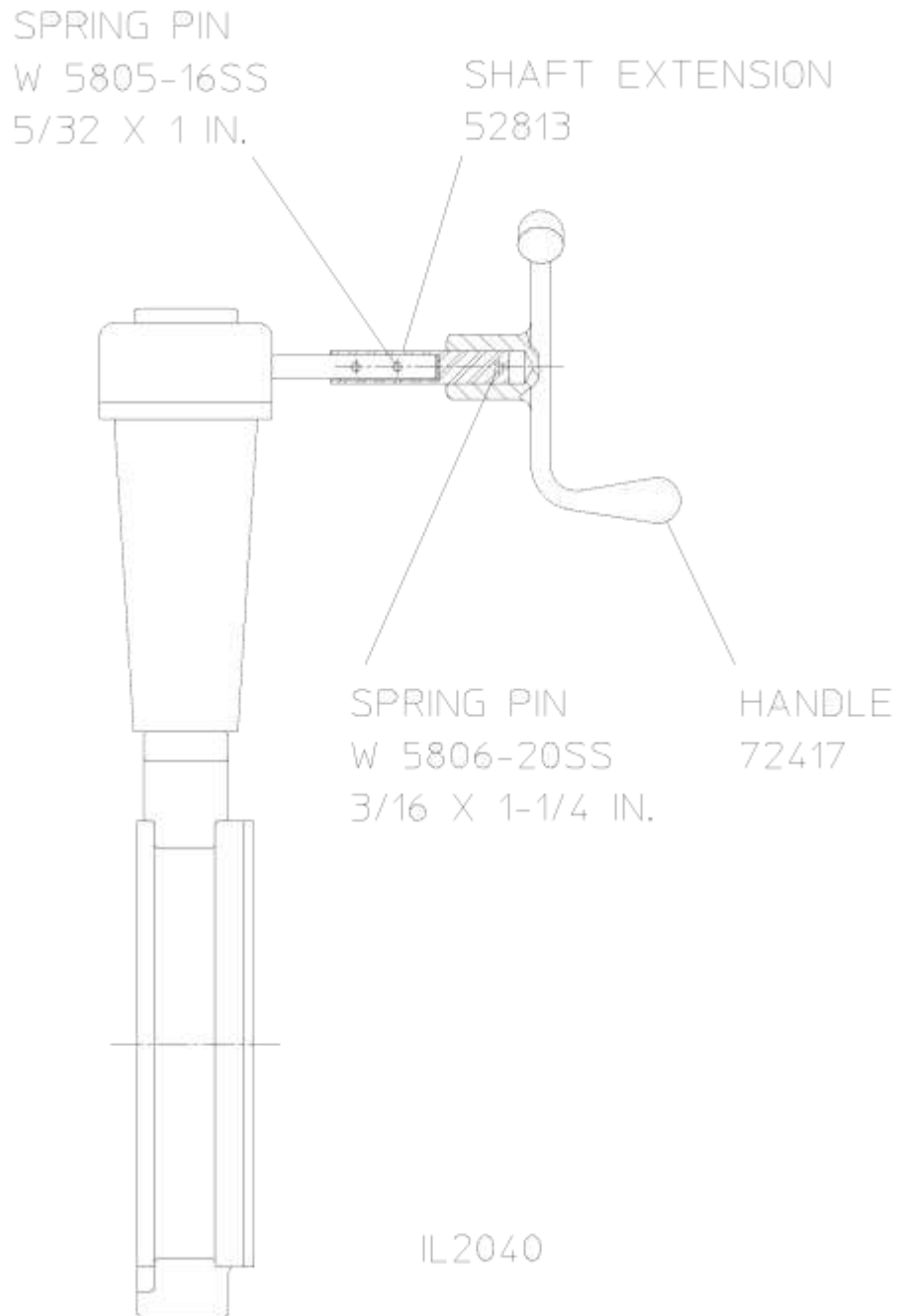

1. Insert shaft extension (P/N 52813) onto butterfly valve and fasten with 5/32 x 1" long spring pin (P/N W5805-16SS).
2. Drill 0.187" thru opposite end of shaft extension where handle location is preferred and install handle (P/N 72417 with 3/16 x 1-1/4" long spring pin (P/N W5806-20SS).

NOTE: May need to trim shaft extension shaft for desired handle location.

Pneumatic Actuator – Air Line Connections

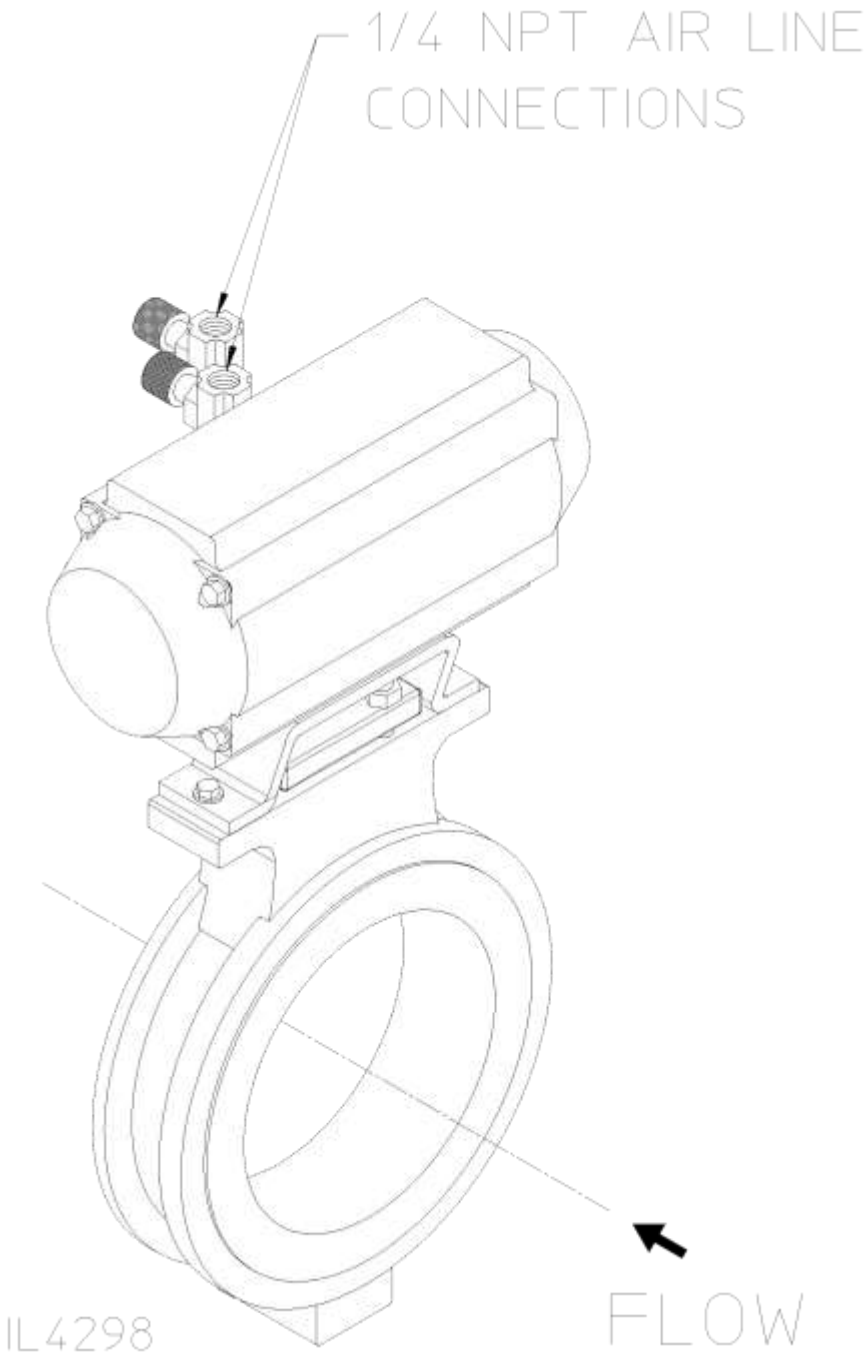

The valve is positioned at the factory with air connections located relative to flow as shown.

TROUBLESHOOTING:

PROBLEM	POSSIBLE CAUSE	SOLUTION
Valve leaking	Scored / Corroded butterfly valve wafer	Clean with emery cloth or replace
Panel LED's all illuminated constantly	Encoder not grounded	Check for ground on encoder assembly
	Defective encoder	Unplug encoder from panel – if LED's turn off, replace encoder
Valve Position LED's NOT illuminated	No power to panel	Check for power supply to panel
	Encoder not grounded	Check for ground on encoder assembly
	Defective encoder	Unplug encoder from panel – if all LED's turn off, replace encoder
	Defective panel	Connect jumper wire from 12V red wire deutsch connector to each other pin of the connector – should light the individual LED's on the panel
Electric Valve doesn't open or close	Defective switch	Check for proper connections
	Motor to switch connection	Check wiring from motor to switch
	Defective motor	Unplug connection at motor and measure motor continuity with an Ohm meter – should be less than 5 Ohms
	No power to panel	Check for power supply to panel
Motor runs constantly	Defective switch / short circuit across switch	Check for circuit across switch – replace in necessary