

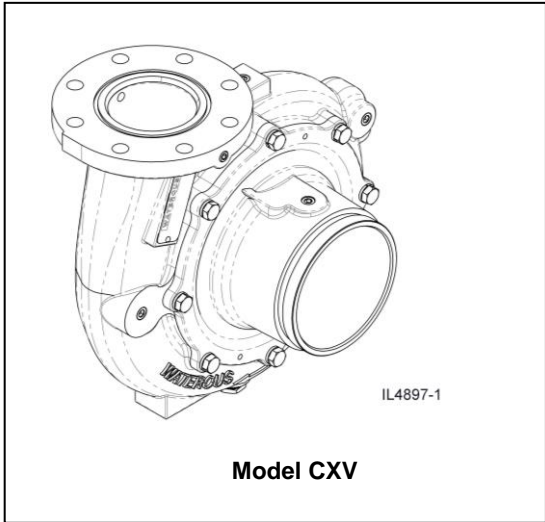

Fire Pump Models CXN, CXS and CXV Installation Instructions

Waterous Fire Pumps may be ordered with a variety of accessories.
Refer to the following separate installation instructions as necessary:

- Auto Tank Fill System
- Butterfly Valves
- CAF System
- Discharge Valves
- Drain Valves
- Foam System:
 - Foam Pump
 - Foam Pump Flush Kit
 - Foam Fill
 - Dual Foam Injection Kit
 - Dual Tank Selector
 - Overboard Foam Pick-up
 - Remote Start Kit
- Overheat Protection Manager (OPM)
- Pump Shift (Pneumatic)
- Pressure Control System:
 - Discharge Relief Valve
 - Intake Relief Valve
 - Pressure Governor
- Priming System

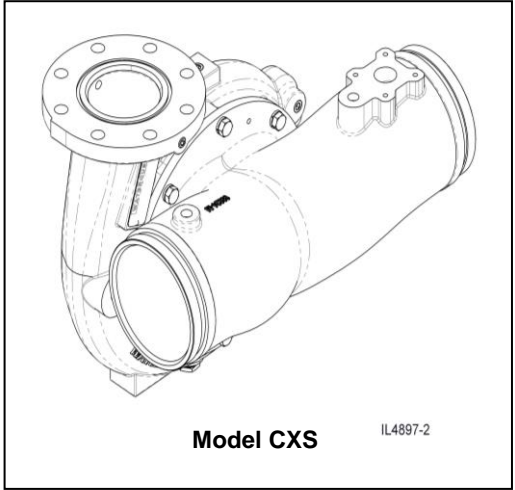
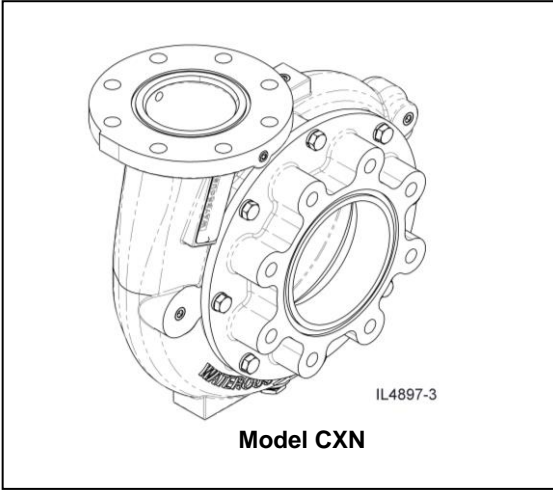

Read through safety information and installation instructions carefully before installing your Waterous Fire Pump.

Note that Instructions are subject to change without notice.

F-1031, Section 3014
Revised: 7/14/20

Table of Contents:

Safety Information	3	Transmission Oil Cooler Drain, K and T Models	15
Pump Orientation Definitions	4	Tachometer Connection:	
Pump Intake and Discharge Connections	4	Available on C20 Series and PA Transmissions Only.....	16
Available Pump Drives	4	Optional Corrosion Protection	17
Pump Mounting	5	Final Checks:	
Mounting Locations:		Lubrication.....	18
Pump Intake Adapter:		Testing.....	18
CXN, CXS and CXV Models.....	5	C20 Series Transmission Temperature Specifications.....	18
Pump Transmissions:			
With C20 Series Transmission:			
Pump Mounted on Front (Input Shaft Side) of Transmission.....	6		
Pump Mounted on Rear (Output Shaft Side) of Transmission.....	7		
With Direct Drive, No Transmission.....	8		
With PA Model Transmission.....	9		
With K Model Transmission.....	10		
With T Model Transmission.....	11		
With QB Model Transmission:			
Pump Mounted on Front (Input Shaft Side) of Transmission.....	12		
Pump Mounted on Rear (Opposite Side of Input Shaft) of Transmission.....	13		
Optional Suspension Pin Mounting Method:			
Models CXSK, CXXK and CXVK Only.....	14		



Read through and communicate safety information to the end user of this Waterous Fire Pump.

 **WARNING**

Death or serious personal injury might occur if proper operating procedures are not followed. The pump operator, as well as individuals connecting supply or discharge hoses to the apparatus must be familiar with these pump operating instructions as well as other operating instructions and manuals for the apparatus, water hydraulics and component limitation.

 **WARNING**

Pressure Hazard. May result in personal injury.

Prior to connection or removal of hoses, caps or other closures with pump intake or pump discharge connections, relieve pressure by opening drains or bleeder valves. Bleeder valves should also be used while filling a hose connected to an intake with water.

 **WARNING**

Scalding Water Hazard. May result in serious burns.

When operating the pump, be sure to open at least one discharge valve slightly to prevent the pump from overheating. If the pump runs for a few minutes completely closed, it may heat the water enough to scald someone when the valve is opened. Overheating can damage the packing, seals and other pump parts. If the apparatus builder has installed a by-pass system or other provision designed to prevent overheating, opening a discharge valve may be unnecessary.

 **WARNING**

Rotating Parts Hazard or Unexpected Truck Movement. May result in serious personal injury or death.

Stop the engine, set parking brake and chock the wheels before going under the truck to adjust packing or to check packing gland temperature.

OEM Installation Warnings

 **WARNING**

Unexpected Truck Movement. May result in serious personal injury or death.

Failure to properly install the pump shift control and pump shift indicator system in the apparatus or failure to incorporate in the Pump Operator's Panel Engine Speed Interlock System may result in unexpected truck movement which may result in serious personal injury or death.

 **WARNING**

Inability to Pump Water. May result in serious personal injury or death.

Failure to properly install the pump shift control and pump shift indicator system in the apparatus or failure to incorporate in the Pump Operator's Panel Engine Speed Interlock System may result in the inability to pump water which may result in serious personal injury or death.

 **WARNING**

Exceeding Power Train Torque Ratings. May result in inability to pump water causing serious personal injury or death.

This fire pump may have the capability under certain pumping conditions to exceed the torque rating of the power train.

A means to control the engine output to a torque level no greater than the power train's continuous-duty torque rating must be considered when specifying power train components and engine control system parameters.

Pump Orientation Definitions

Pump and Vehicle Location Definitions used in this Instruction

Fire Pump Location	Relative to Vehicle Location (Vehicle with Left Side Driver's Controls)
Front	Front (Driver's Controls)
Rear	Rear (Rear Wheels)
Left	Driver's Side
Right	Passenger or Curb Side
Top	Up
Bottom	Down

Pump Intake and Discharge Connections

Pump Model	Intake	Discharge
CXN	DIN PN10 150 Flange	Various Options: Manifold with 3-1/2 in. end flanges and two 2-1/2 in. 4-bolt pads, Manifold with 4 in. end flanges and eight 2-1/2 in. 4-bolt pads, 4 in. ANSI Flange
CXS	Left and Right 6 in. Victaulic®, Front 5 in. Victaulic®	
CXV	Single 6 in. Victaulic®	

Available Pump Drives

Drive	Transmission				Complete Pump and Transmission Model		
	Type	Series	Model	Input Shaft Rotation	CXN	CXS	CXV
PTO	None, Direct Drive from PTO	D	D	Clockwise or Counter Clockwise	CXND	CXSD	CXD
	Two Gear Speed Increaser	K	K	Clockwise or Counter Clockwise	CXNK	CXSK	CXVK
	Chain Drive Speed Increaser	P	PA	Clockwise	CXNPA	CXSPA	CXVPA
		Q	QB	Clockwise	-	-	CXVQB
Directly Mounted to an Engine	Two Gear Speed Increaser	T	T	Clockwise or Counter Clockwise	CXNT	-	CXVT
Split Shaft	Chain Drive Speed Increaser	C20	C20B C20C C20D C20E C20F	Clockwise	CXNC20B CXNC20C CXNC20D CXNC20E CXNC20F	CXSC20B CXSC20C CXSC20D CXSC20E CXSC20F	CXVC20B CXVC20C CXVC20D CXVC20E CXVC20F

Pump Mounting

Select a mounting location which will make the pump and its accessories readily accessible for maintenance and which will make the pump driveshaft parallel with the output shaft of the chassis transmission or transfer case. Also, select the location so that when the apparatus is loaded, the universal joints on the propeller shaft will have a proper working angle. Be sure the propeller shaft used are of the slip-joint design. Frame deflection, temperature changes and similar factors may cause a propeller shaft without slip-joints to produce severe axial loads on the bearings and damage the pump.

Driveline End Yokes and Companion Flanges: Anti seize should be applied to the shaft threads before installing end yoke or companion flange. Do not reuse self-locking nuts, torque to 275-325 lb-ft.

Brackets must be fabricated to attach to the mounting points of the pump body and transmission and the chassis frame. Tighten the mounting hardware to standard torque specifications.

Note that Waterous does not furnish the brackets.

Mounting Locations on Pump Intake Adapter

Use the pump intake adapter screws for attaching the bracket.

Remove the screws furnished with the pump and use 1/2 in. longer screws to compensate for the bracket thickness.

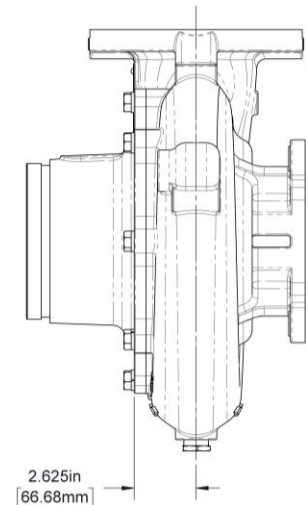
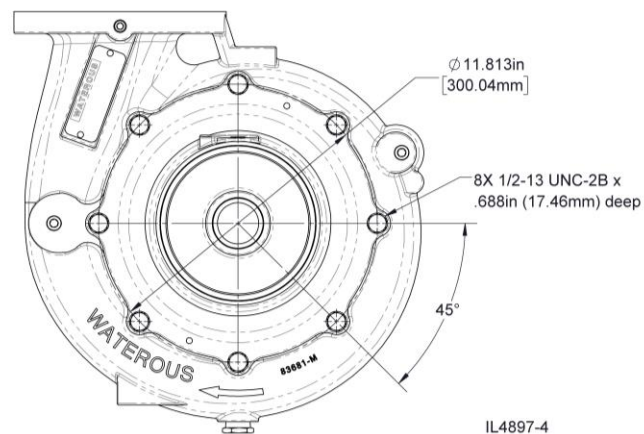
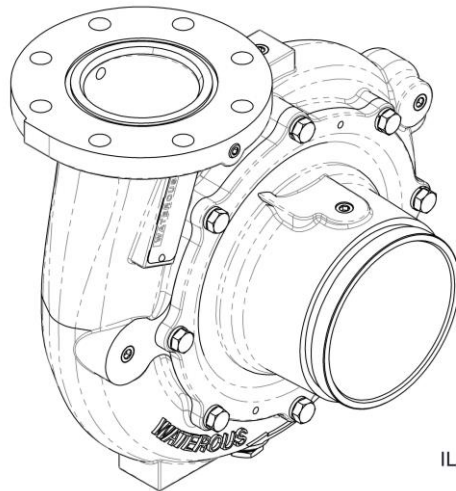

Mounting Locations – With C20 Series Transmission

Pump Mounted on Front (Input Shaft Side) of Transmission

Note that the Pump Discharge may be only positioned Up and the Transmission may only be mounted Vertical.

Refer to the Pump Dimensional Drawing for details specific to your pump.

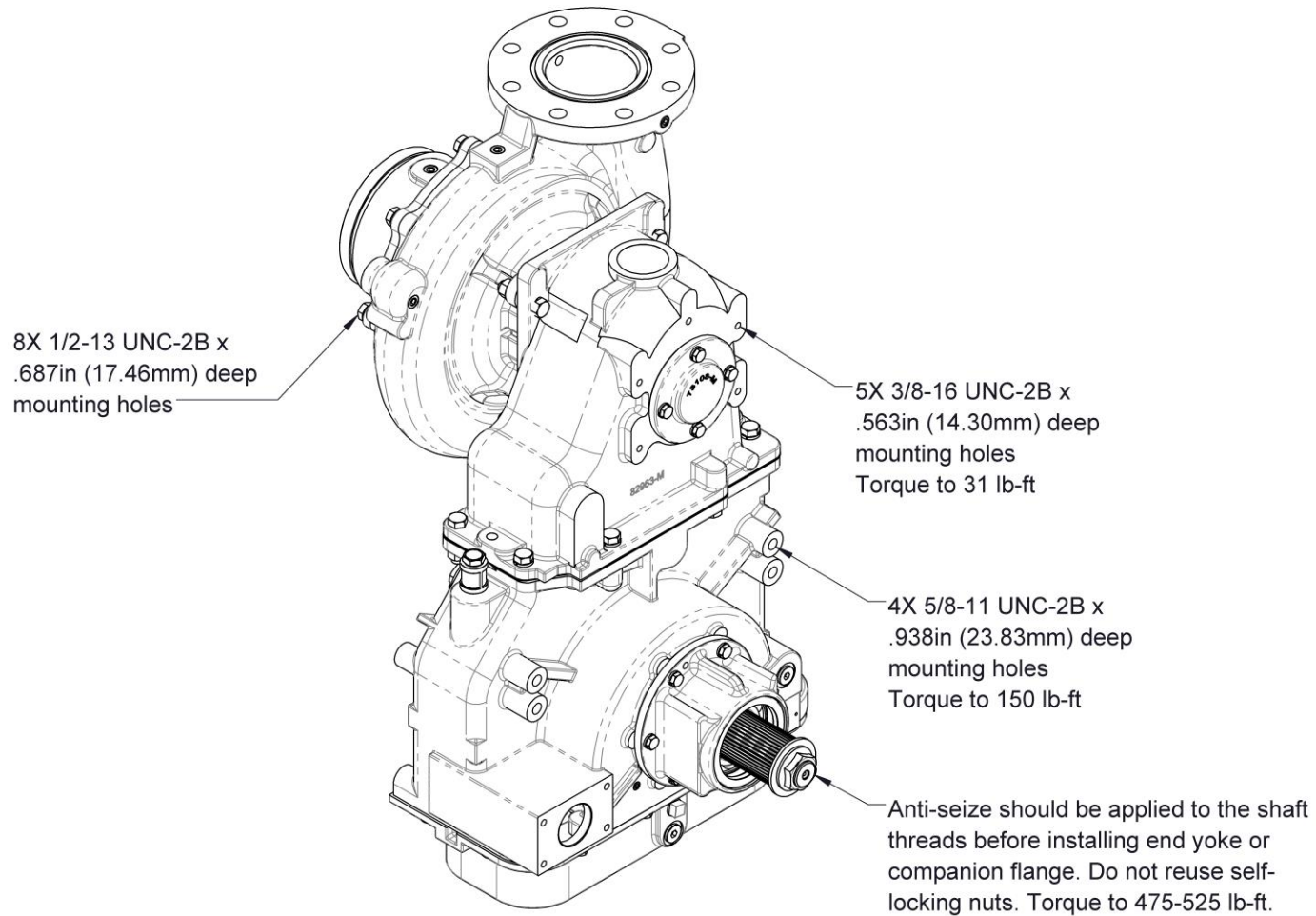

IL4897-5

Mounting Locations – With C20 Series Transmission

Pump Mounted on Rear (Output Shaft Side) of Transmission

Note that the Pump Discharge may only be positioned Up and the Transmission may only be mounted Vertical.

Refer to the Pump Dimensional Drawing for details specific to your pump.

5X 3/8-16 UNC-2B x
.563in(14.30mm) deep
mounting holes
Torque to 31 lb-ft

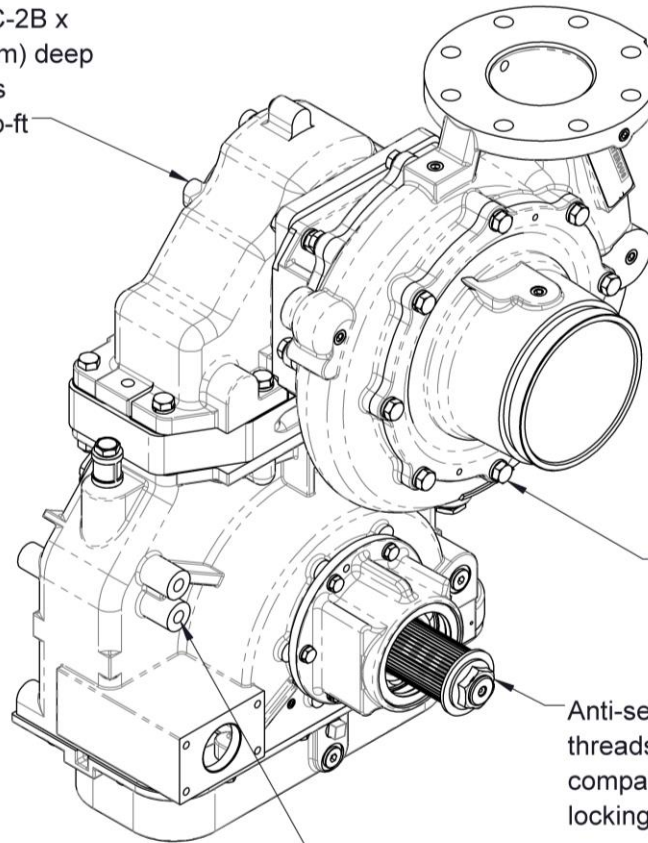

8X 1/2-13 UNC-2B x
.687in(17.46mm) deep
mounting holes

Anti-seize should be applied to the shaft
threads before installing end yoke or
companion flange. Do not reuse self-
locking nuts. Torque to 475-525 lb-ft.

4X 5/8-11 UNC-2B x
.938in(23.83mm) deep
mounting holes
Torque to 150 lb-ft

IL4897-6

Mounting Locations – With Direct Drive, No Transmission

Note that the Pump Discharge may be positioned Up, Right, Left or Down. The Bearing Housing will always point down.

Refer to the configuration of the pump you ordered and Pump Dimensional Drawing for details specific to your pump.

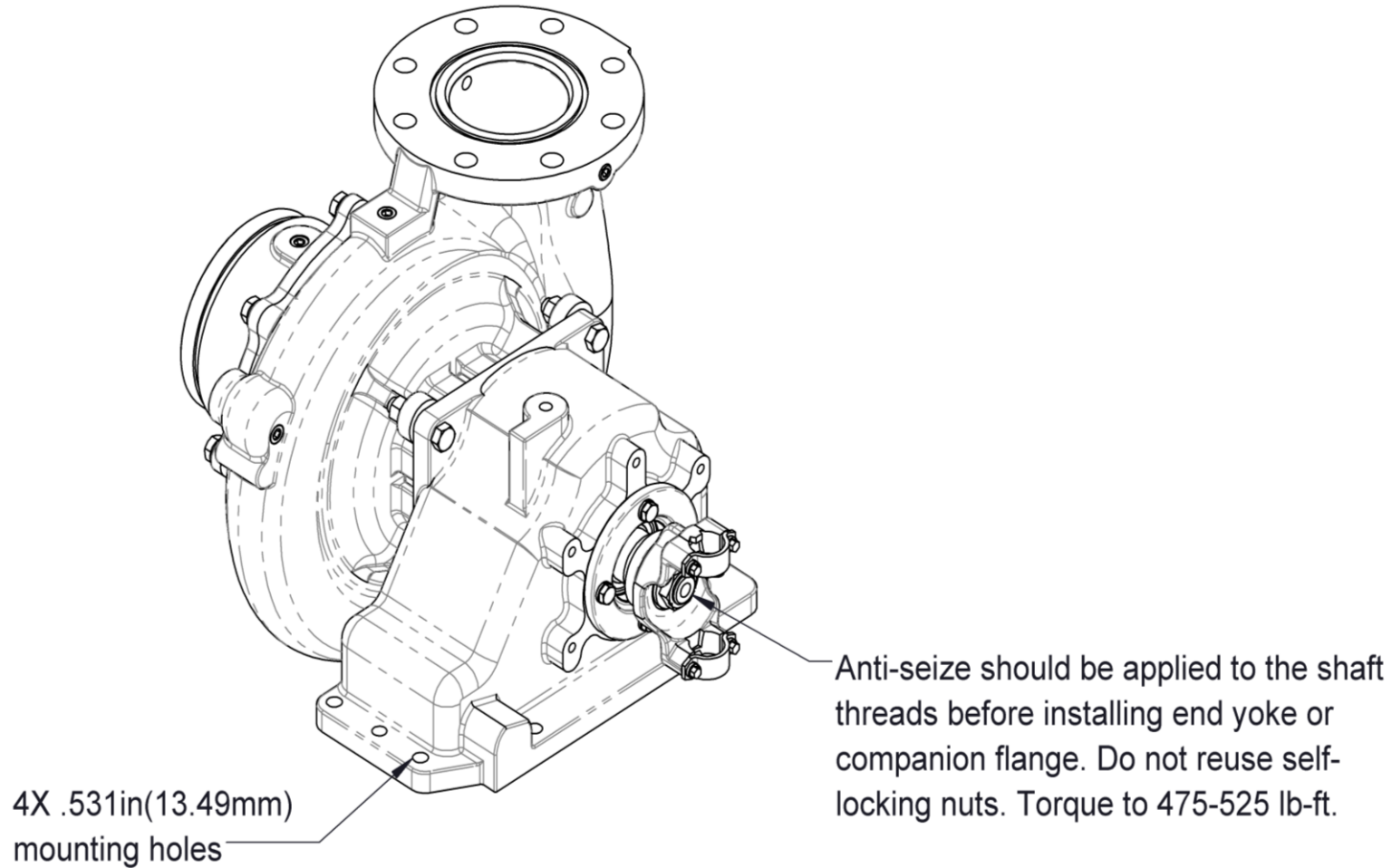

IL4897-7

Mounting Locations – With K Model Transmission

Note that the Pump Discharge only may be positioned Up, Right, Left or Down. The Transmission may be mounted Vertical, Right, Left or Inverted.

Refer to the configuration of the pump you ordered and Pump Dimensional Drawing for details specific to your pump.

8X 1/2-13 UNC-2B x
.687in (17.46mm) deep
mounting holes

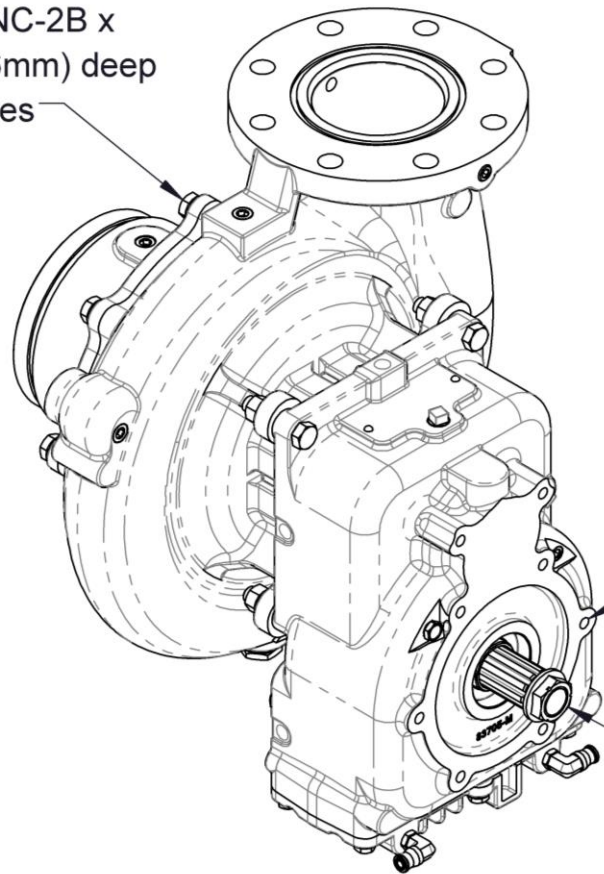

8X 7/16-14 UNC-2B x
.625in (15.75mm) deep
mounting holes

Anti-seize should be applied to the shaft
threads before installing end yoke or
companion flange. Do not reuse self-
locking nuts. Torque to 275-325 lb-ft.

IL4897-9

Mounting Locations – With PA Model Transmission

Note that the Pump Discharge may be positioned Up, Right, Left or Down. The Transmission may only be mounted Vertical.

Refer to the pump Dimensional Drawing for details specific to your pump.

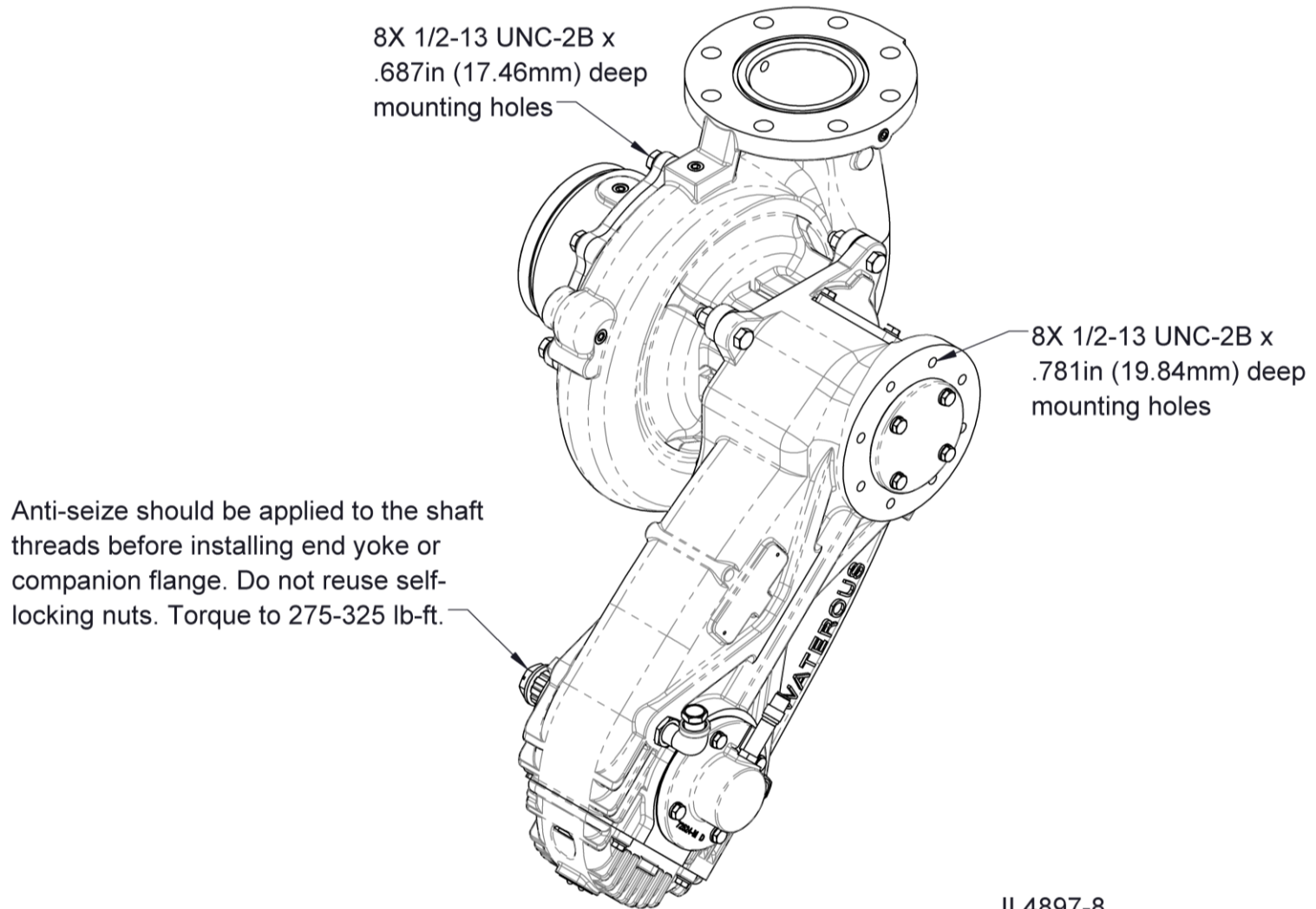

Mounting Locations – With T Model Transmission

Note that the Pump Discharge only may be positioned Up, Right, Left or Down. The Transmission may be mounted Vertical or Inverted.

Refer to the configuration of the pump you ordered and Pump Dimensional Drawing for details specific to your pump.

Pump is mounted directly to an engine and will only need to be supported on the intake end. See page 5.

8X 1/2-13 UNC-2B x
.687in (17.46mm) deep
mounting holes

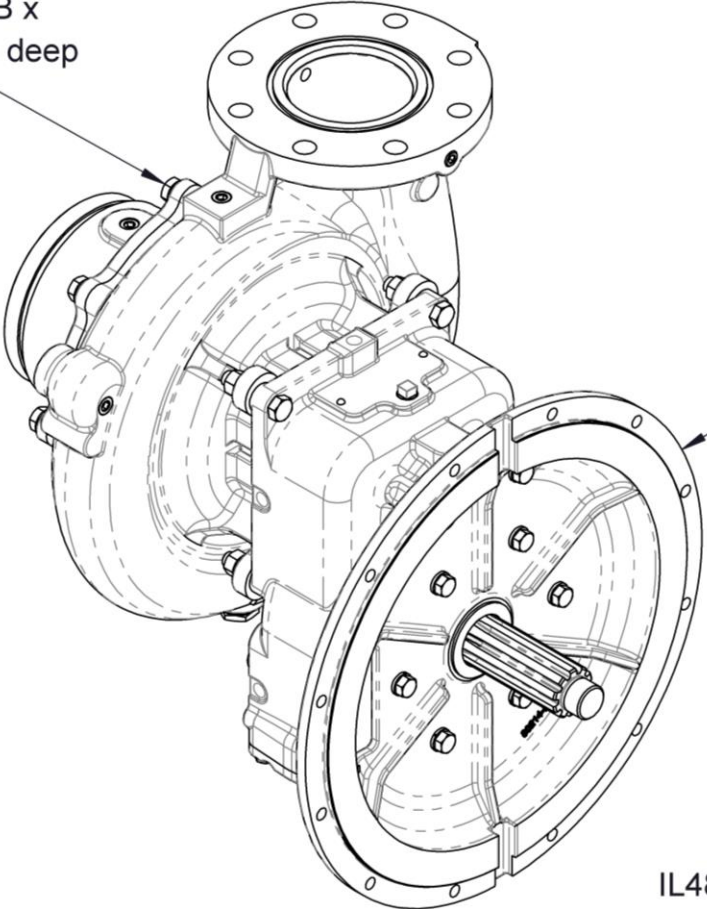

Transmission mounts directly to
engine flywheel housing

IL4897-10

Mounting Locations – With QB Model Transmission

Pump Mounted on Front (Input Shaft Side) of Transmission

Refer to the pump Dimensional Drawing for details specific to your pump.

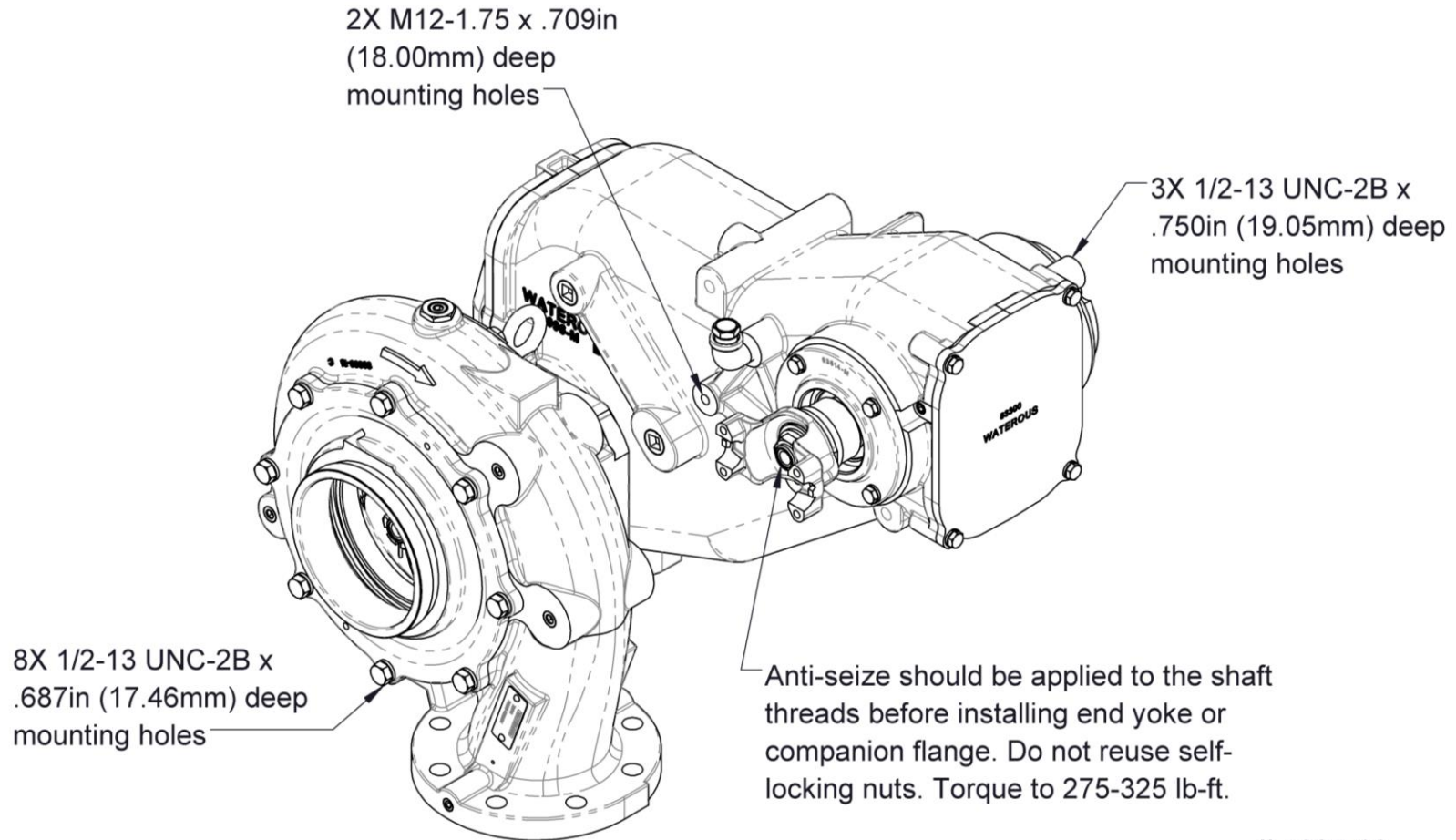

IL4897-11

Mounting Locations – With QB Model Transmission
Pump Mounted on Rear (Opposite Side of Input Shaft) of Transmission

Refer to the pump Dimensional Drawing for details specific to your pump.

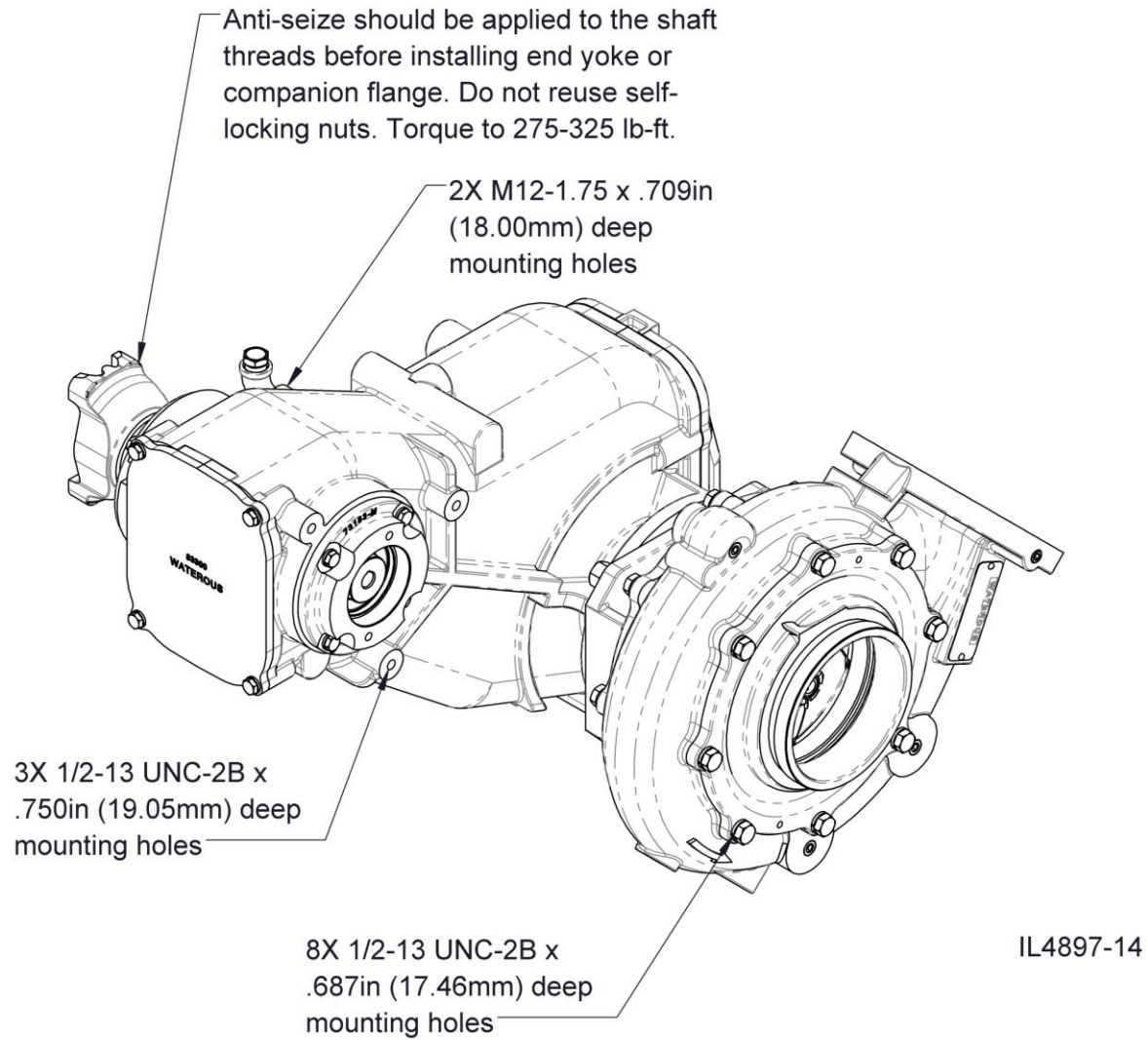

Optional Suspension Pin Mounting Method Models CXNK, CXSK and CXVK Only

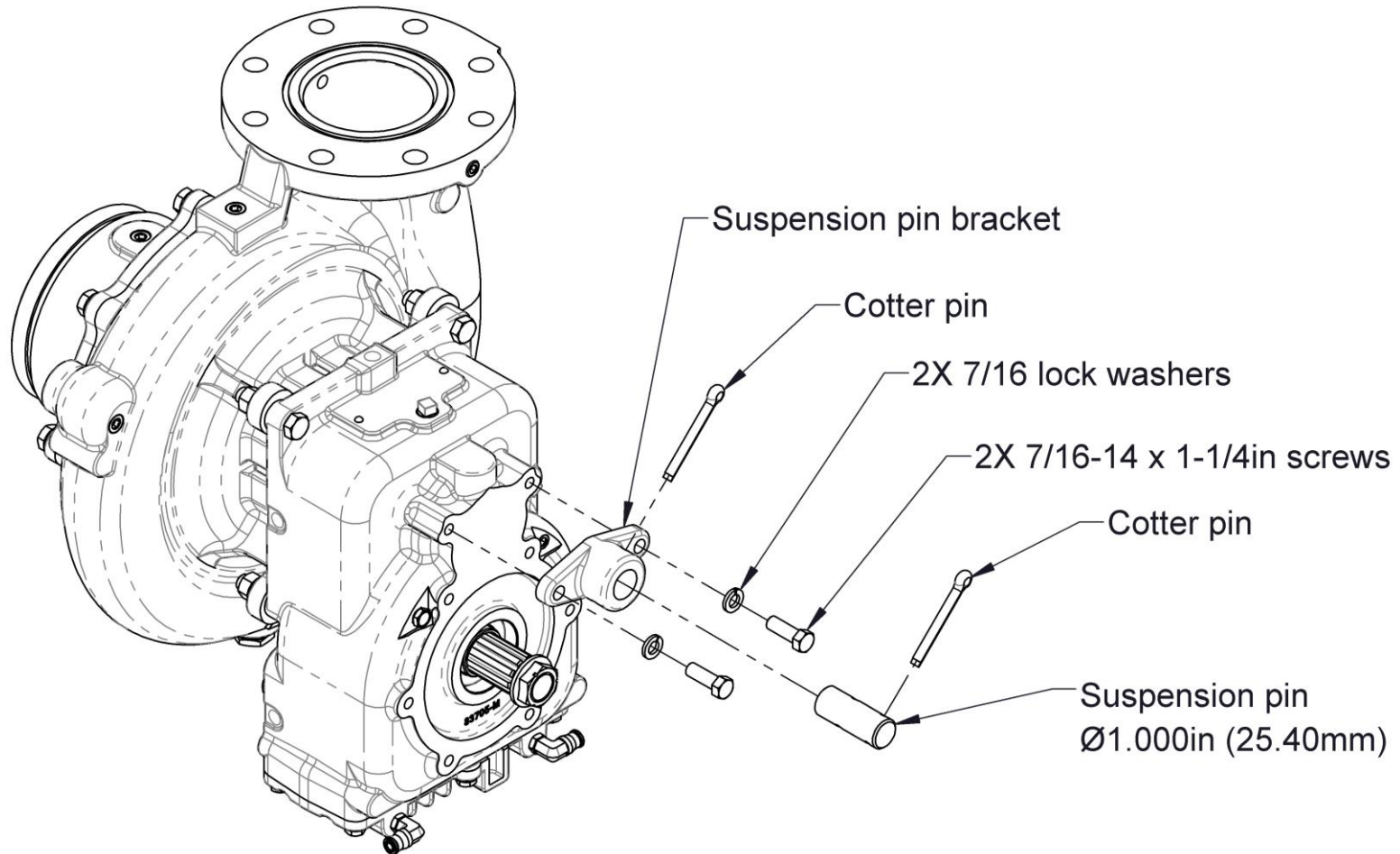

IL4897-12

Transmission Oil Cooler Drain K and T Model Transmissions

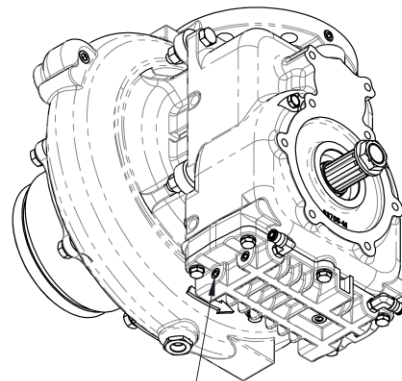

Oil Cooler Drain,
1/4 NPT

Vertical Transmission Mounting

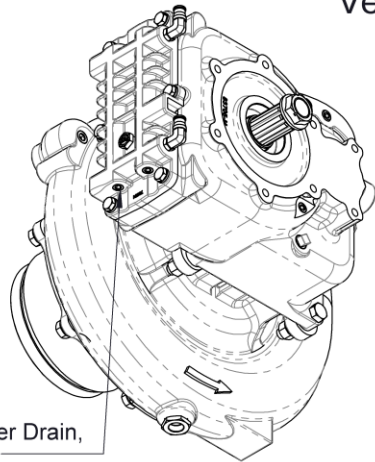

Oil Cooler Drain,
1/4 NPT

Left Transmission Mounting

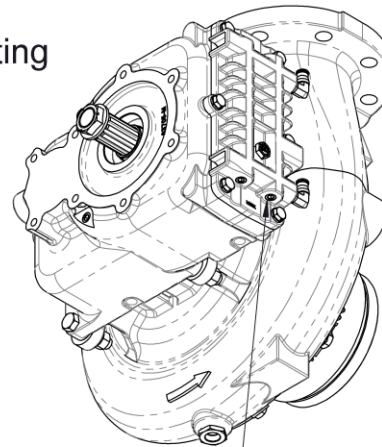

Oil Cooler Drain,
1/4 NPT

Right Transmission Mounting

IL4897-13

Note:

Inverted transmission mounting does not require an oil cooler drain as the water will drain through the pump.

Tachometer Connection
Electronic Tachometer
Optional on C20 Series Transmissions
Standard on PA Model Transmissions

The magnetic pick-up in the transmission mates with an Amphenol connector (P/N MS3106A-10SL-4S).

This connector should be wired to a wall mount receptacle on the operator's panel.

Cable assembly part number 63033 is available from Waterous.

C20 Series Transmissions

To verify the rotational speed of the drive shaft, the frequency (Hz) reading from the tachometer sensor should be multiplied by 10.

$$\text{Hz} \times 10 = \text{RPM}$$

PA Model Transmissions

To verify the rotational speed of the drive shaft, the frequency (Hz) reading from the tachometer sensor should be multiplied by 6.

$$\text{Hz} \times 6 = \text{RPM}$$

NOTE: Frequency reading can be measured with a hand held multimeter.

Cable connector assembly part number V 3398 is available from Waterous for connecting panel mounted receptacle to multimeter.

Optional Corrosion Protection

Intake Screens

Waterous offers intake screens that fit 4, 4-1/2, 5 and 6 inch intake fittings sizes. The screen is designed to fit in the counter bore in the inside diameter of the fittings. There must be a strong electrical contact between the screen and the intake fitting. Remove any corrosion, debris or paint from the counter bore that will insulate the screen from the intake fitting. If the screen does not fit tightly, adjust the gap of the slot on the outside diameter of the screen to ensure a tight fit.

NOTE: Intake screen are die-cast which results in a slight taper from one side to the other. Install the screen with the thinner cross-section facing out to minimize flow restriction.

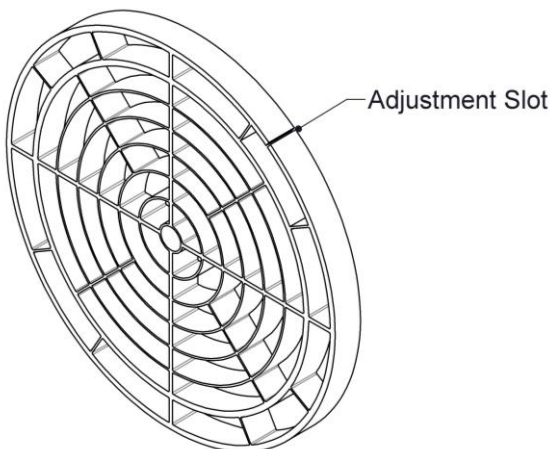

Intake Screen

IL4417-1

Anodes

Anodes may be mounted in the intake piping or, if no intake pads are available, in the discharge piping.

NOTE: The replaceable elements must make contact with water to be effective. Do not paint or use any other coating on the replaceable elements.

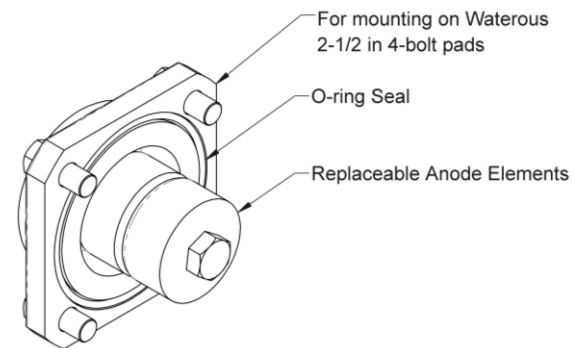

4-Bolt Anode

IL4417-2

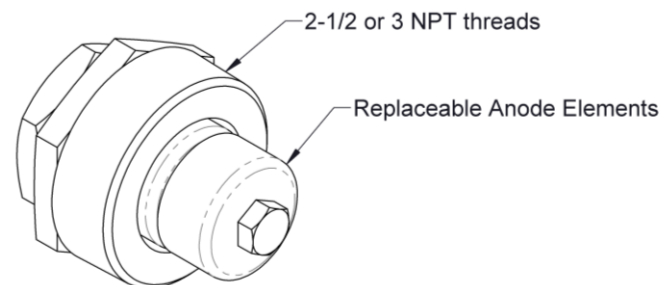

Threaded Anode

IL4417-3

Final Checks

Lubrication

Transmissions are shipped without lubricant and must be filled before the pump is operated.

NOTICE
Failure to properly lubricate the pump transmission may result in serious damage to the equipment.

The types of recommended lubricants are listed below:

Transmission Model	Capacity (Quarts or Liters) <i>(See Note 1)</i>	Lubricant <i>(See Note 2)</i>
C20B, C20C, C20D C20E, C20F	6	ATF (All Climates), or for Ambient Temperatures over 90°F/32°C: SAE 20 Oil 300 SSU @ 100°F with service classification SA, SB, SC should be used
PA	1	
QB	4-1/2	
K	1	SAE 80W-90 Gear Oil
T	1	
D <i>(No Transmission)</i>	Bearing Housing has Sealed Bearings, Lubricant not required	

Notes:

- 1) Capacities shown are approximate Quarts or Liters, always fill to the bottom of the plug labeled "Oil Level" or sight glass. Quantities listed vary based on ratio and/or mounting orientation.
- 2) Synthetic ATF and oil substitutes are preferred.

Testing

Perform the tests listed in F-1031, Section 1000, "Centrifugal Fire Pump Principles of Operation, Inspection Tests and Troubleshooting Guide." During the running tests, monitor the smoothness of operation, listen for unusual noises and check for leaks.

C20 Series Transmission Temperature Specifications

The maximum temperature permitted at transmission external surfaces is 250°F (121°C).