

Eclipse™ ES CAFSystem with CX Series Fire Pumps

Installation Instructions

Form No.	Section	Issue Date	Rev. Date
F-1031	3028	07/23/09	2/14/20

Table of Contents

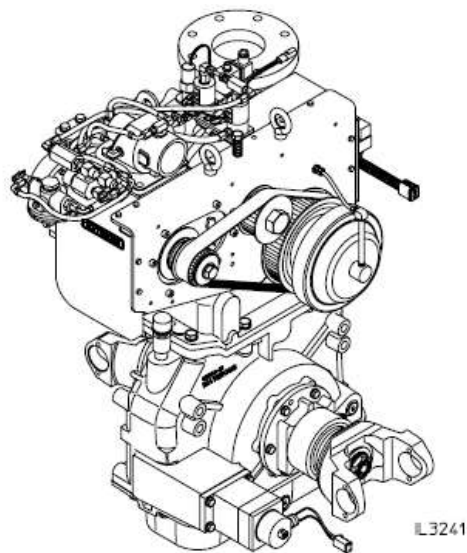

Safety Information	2	Lubrication:	
Introduction	2	Pump Transmission	19
Components	3, 4	Air Compressor.....	19
Installation:		Electrical Wiring:	
Mounting:		Compressor:	
Clearances Required for Maintenance	5	Wiring Schematic	20
CX Series Fire Pump	6	Power to Compressor Relay Panel	21
Compressor:	6	Air Clutch Engage Switch	21
General Guidelines	6	“Throttle Ready” Interlock Loop	22
Dimensions of Components.....	7	Electric Auto-Sync Panel:	
Oil and Water Line Schematic	8	Wiring to Relay Panel	23
Air Filter.....	9	Schematic	24
Oil Sump and Oil Temperature Sensor	10	Air Clutch Solenoids.....	25
Air/Oil Separator.....	11	Air Discharge Solenoids	26
Oil Cooler	12	Compressor Overheat Light and Alarm.....	27
Wye Strainer for Oil Cooler Water Line	13	Compressor Oil Temperature Gauge	27
Compressor Panel Components:		Oil Temperature Sensor	28
Electric Auto-Sync Panel.....	14	Suggested Third Party Components	
Oil Temperature Gauge	14	Air Flow Meter	29
Master Air Pressure Gauge	14	Master Air Pressure Gauge	29
Panel Plates	14	Air Lines Between Components	29
Compressor Air Connections:		Hydraulic Lines Between Components	29
Air Line Schematic.....	15	CAFS Discharge Components	29, 30
Air Filter	15	Initial Power-Up	31
Master Air Pressure Gauge	15	Calibration:	
Air Clutch Connection	16	Control Air Circuit Schematic.....	32
Air Distribution Ports	17	Electric Auto-Sync System.....	33
Water Drains:		Control Air Circuit Calibration	33
Oil Cooler.....	18	Control Air Circuit Component Locations.....	34
Fire Pump	18	Troubleshooting Guide	35-37
Foam System	18		

Note: Discard shipping brackets. Not to be used to mount pump.

Safety Information



Read through and communicate safety information to the end user of this Waterous Fire Pump.



WARNING

Death or serious personal injury might occur if proper operating procedures are not followed. The pump operator, as well as individuals connecting supply or discharge hoses to the apparatus must be familiar with these pump operating instructions as well as other operating instructions and manuals for the apparatus, water hydraulics and component limitation.



WARNING

Pressure Hazard. May result in personal injury.

Prior to connection or removal of hoses, caps or other closures with pump intake or pump discharge connections, relieve pressure by opening drains or bleeder valves. Bleeder valves should also be used while filling a hose connected to an intake with water.



WARNING

Scalding Water Hazard. May result in serious burns.

When operating the pump, be sure to open at least one discharge valve slightly to prevent the pump from overheating. If the pump runs for a few minutes completely closed, it may heat the water enough to scald someone when the valve is opened. Overheating can damage the packing, seals and other pump parts. If the apparatus builder has installed a by-pass system or other provision designed to prevent overheating, opening a discharge valve may be unnecessary.



WARNING

Compressed Air Pressure Hazard. May result in personal injury.

Compressed air can be dangerous. Make sure the pressure is allowed to bleed down to atmospheric pressure prior to opening any connections or valves.

Introduction

This instruction covers the installation of a Waterous Eclipse^M tem. The Eclipse ES consists of a Waterous CX Series fire pump, C20 transmission and an oil-flooded rotary screw compressor. The Eclipse ES is capable of up to 1250 GPM (4750 L/min) of water and 200 CFM (5.6 m³/min) of air.

Figure 1. EclipseTM ES

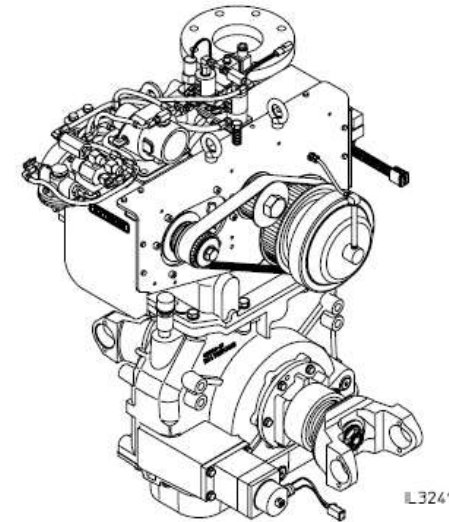

The following installation instructions are available:

- CX Pump Installation, F-1031, Section 3014
- Priming System, F-1031, Section 3023
- Manifold Drain Valves, F-1031, Section 3008
- Overheat Protection Manager (OPM), F-1031, Section 3015

Before proceeding with the installation of the Eclipse^M ES, read the following instructions carefully. Check the appropriate dimensional drawings in the Engineering Manual as needed.

NOTICE

Operating Speed Limit.

May cause damage to the pump and/or air compressor.

The Eclipse compressor has a maximum operating speed of 8950 RPM. Do not allow the compressor to run beyond 8950 RPM.

Compressor speed can be calculated by **(Engine Speed) x (Pump Transmission Ratio) x 2.5**.

Components

Standard Items Furnished

Installed On Compressor		Shipped Loose	
Ref. No.	Description	Ref. No.	Description
1	Fire Pump	16	Air/Oil Separator
2	Fire Pump Transmission	17	Oil Cooler
3	Pneumatic Clutch	18	Air Filter and Elbow
4	PolyChain Belt	19	Compressor Oil Sump
5	Belt Adjustment Hardware	19A	Safety Relief Valve
6	Air Inlet Valve	20	Oil Temperature Gauge
7	Auto Balancing Valve	21	Oil Temperature Sensor
8	Air Clutch Solenoid	22	Oil Cooler Water Strainer and Flush Valve
9	Air Compressor	23	Electric Auto-Sync Control Panel
10	Electrical Relay Panel	24	Air System Operation Panel Plate
11	Balance Trim Valve (BTM)	25	CAFS Hose Specification Plate
12	Air Inlet Trim Valve (AITV)		
13	Transmission Oil Fill		
14	Transmission Oil Level Sight Glass		
15	#4 JIC Connection for Oil Scavenger Line		

Items Not Furnished by Waterous

Item	See Page
Air Flow Meter (Use is Optional)	20
Air Distribution Valves	26
Air Line from Vehicle Air to Air Clutch Solenoid	16
Air Lines Between Components	15
Switch to Engage Air Clutch	25
Master Air Pressure Gauge	15
Hydraulic Hoses Between Components	8
Compressor Overheat Light and Alarm	27
Wiring from Vehicle to Compressor	21
Wiring to "Throttle Ready" Light	22
Wiring to Temperature Sensor	28
Drain Line from Oil Cooler	18
Foam System	18

See Diagram on Next Page

Components (See Page 3 for Details)

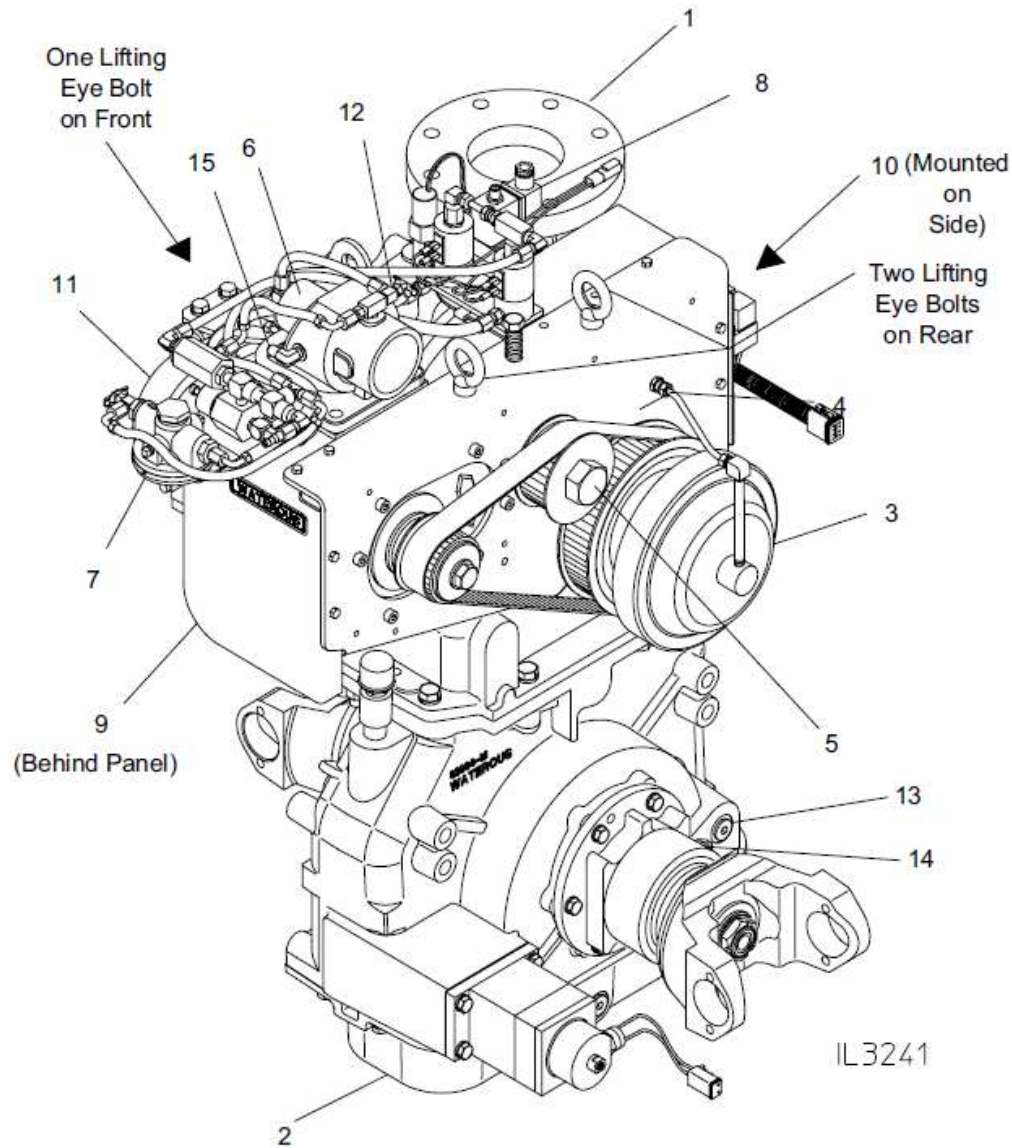

NOTE: Unit shown with belt cover removed.

Items Shipped Loose

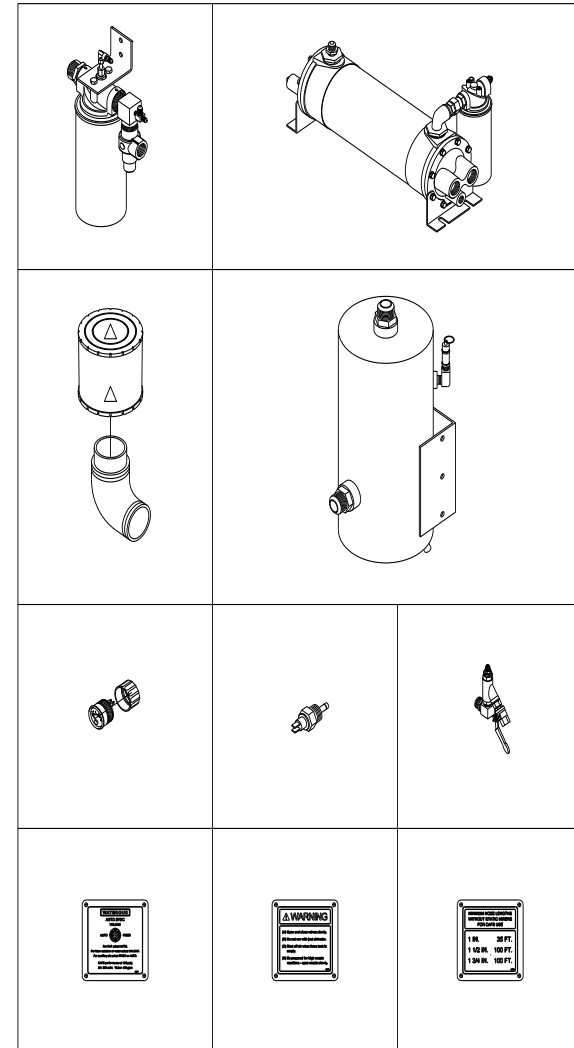

IL300
6

Installation

Mounting

Clearances Required for Maintenance

Compressor Air Clutch

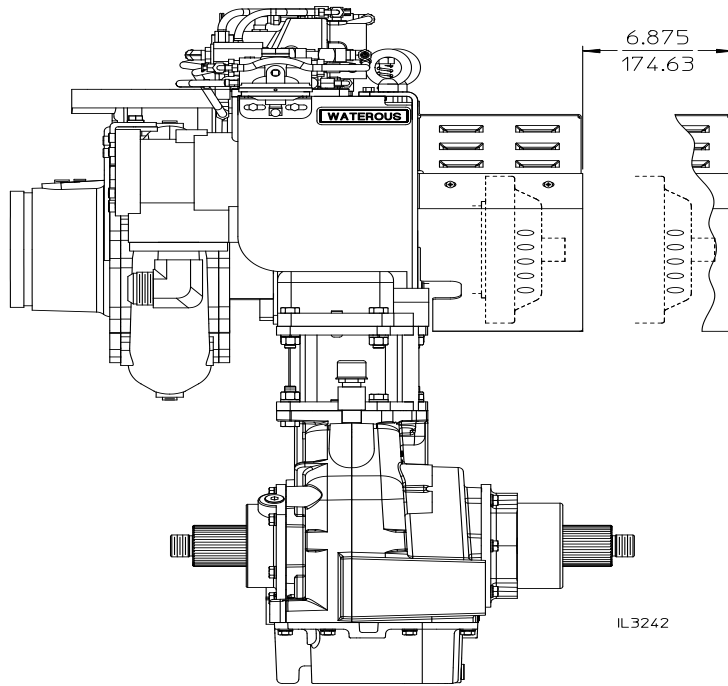

ALL DIMENSIONS SHOWN AS INCH/MILLIMETER
($\frac{\text{INCH}}{\text{MILLIMETER}}$)

Fire Pump Intake Piping

Provisions must be made in the intake piping to allow for the removal of the intake adapter and impeller while the pump is mounted in the vehicle. This is necessary to provide access to the pump mechanical seal for maintenance. Failure to provide access for removal of the intake adapter will result in it being necessary for the end user to remove the entire pump and transmission from the vehicle to service the mechanical seal.

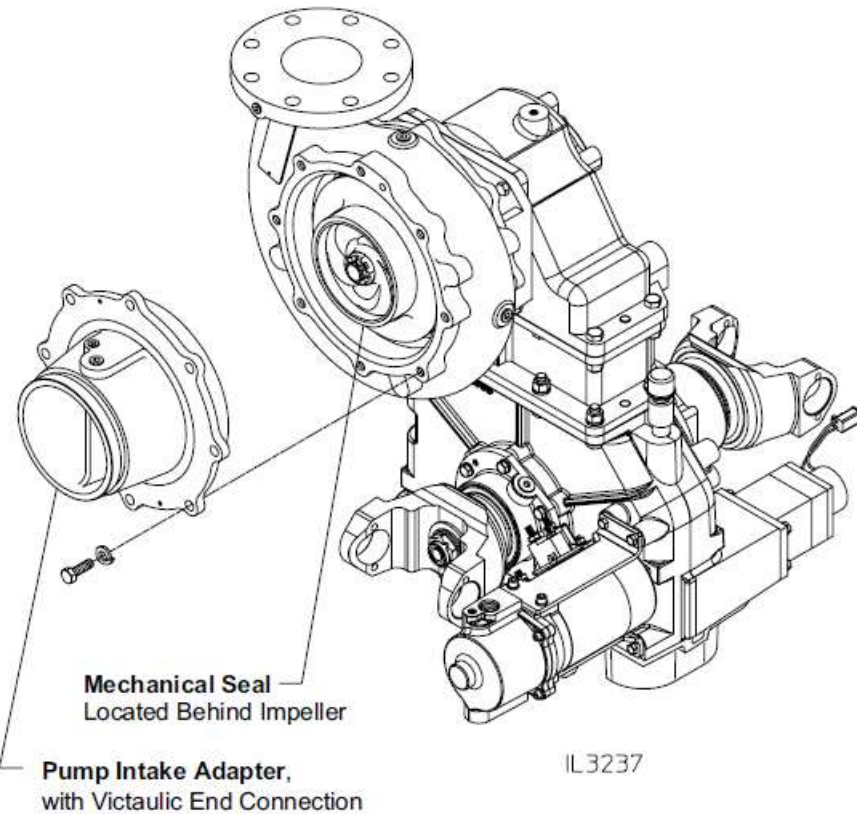

CXSeries Fire Pump

Refer to F1031, Section 3014, **CX Series Fire Pump Installation Instructions**. See Page 22 for wiring interface between compressor and pump shift throttle ready panel.

Compressor General Guidelines

NOTICE

Do not damage the vehicle chassis (also called frame or undercarriage) during installation. Check with the vehicle manufacturer to make sure the planned weld and bolts are in acceptable areas.

- Components must be bolted to brackets welded to the pump compartment frame or bolted directly to the pump compartment frame.
- Allow enough clearance for routine maintenance, including clearance for checking oil, adding oil, adjusting pressure, changing filters, cleaning screens or opening drain valves.
- The sump (oil/air reservoir) can be mounted at the same level as the compressor or below it. If the sump must be mounted above the compressor (12 inches maximum), contact Waterous for the correct check valve to prevent compressor flooding.
- The sump must be horizontal, level and in the proper orientation. Do not relocate or extend the sight glass.
- The oil sight glass must be visible after all the components are installed so oil level can be monitored easily.
- The heat exchanger must be installed horizontally with the drain at the lowest point.
- To prevent damage to hydraulic and air lines or accidentally disconnecting them, run them along the support beams of the pump compartment whenever possible, bundled with cable ties or other fasteners.
- Wire, hoses or tubing that passes through metal, such as a compartment panel, must have a protective bushing or shield around the edge of the hole to protect against abrasion.
- To make troubleshooting easier, use colored air hoses as supplied and shown on the air schematic (see Page 32 for color coding - Do not paint air hoses).
- Labeling the lines is strongly recommended.

Compressor Component Dimensions - Oil Sump

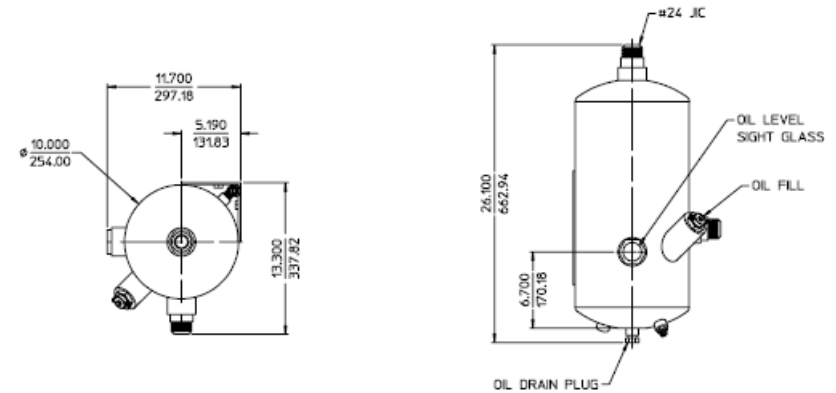

ALL DIMENSIONS SHOWN AS INCH/MILLIMETER
(INCH / MILLIMETER)

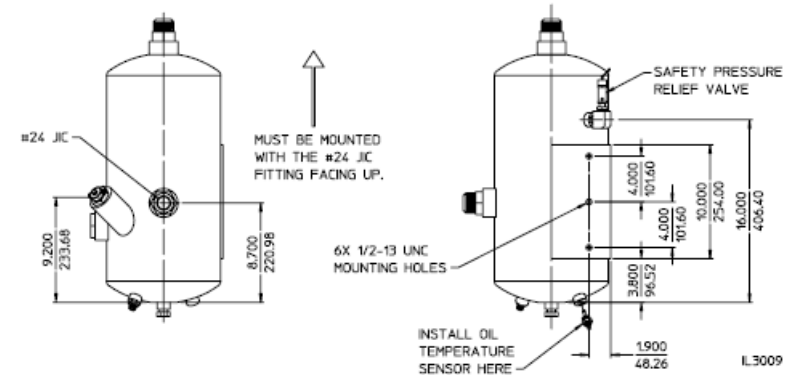

Compressor - Dimensions of Components

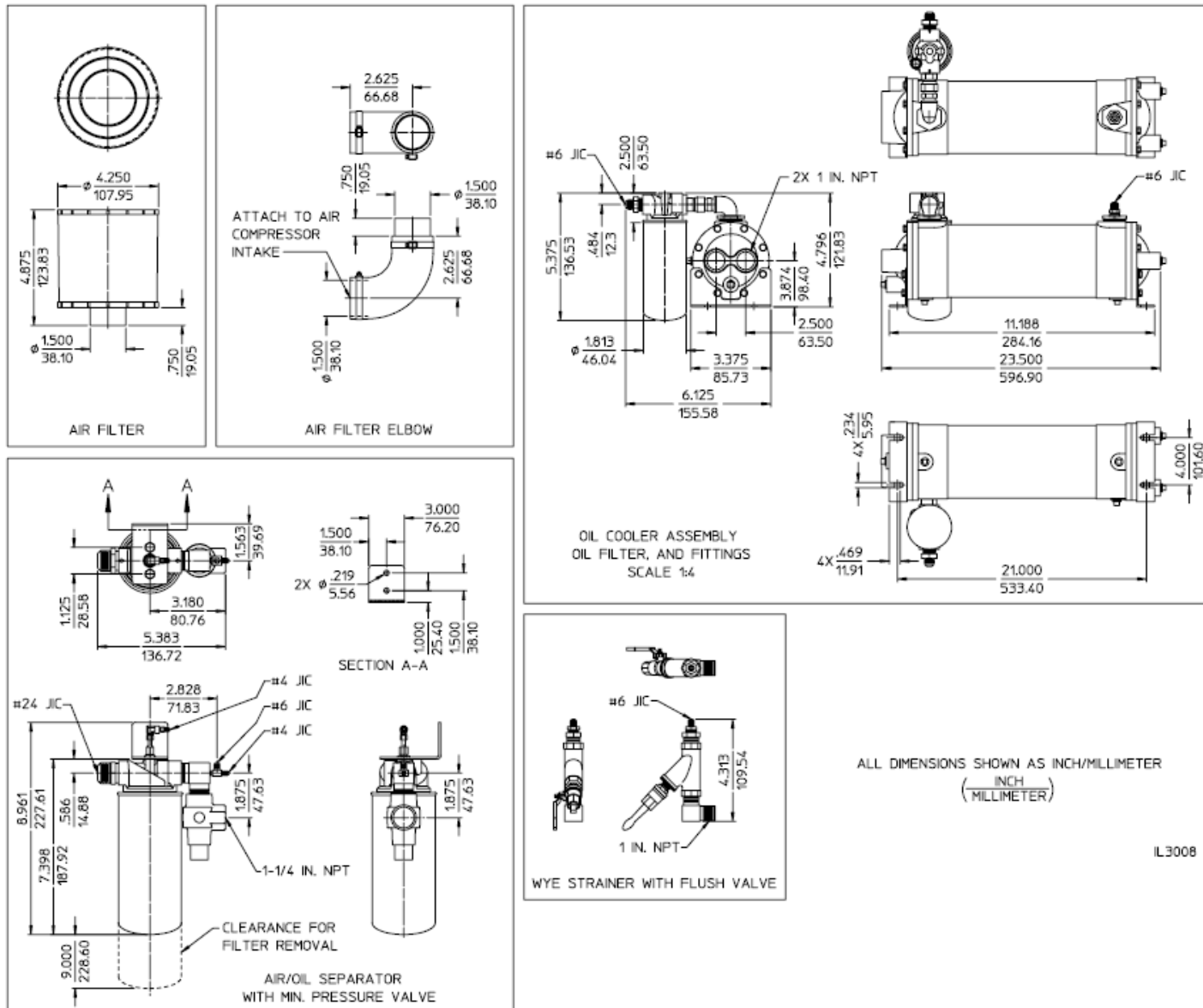

Compressor - Oil and Water Line Schematic

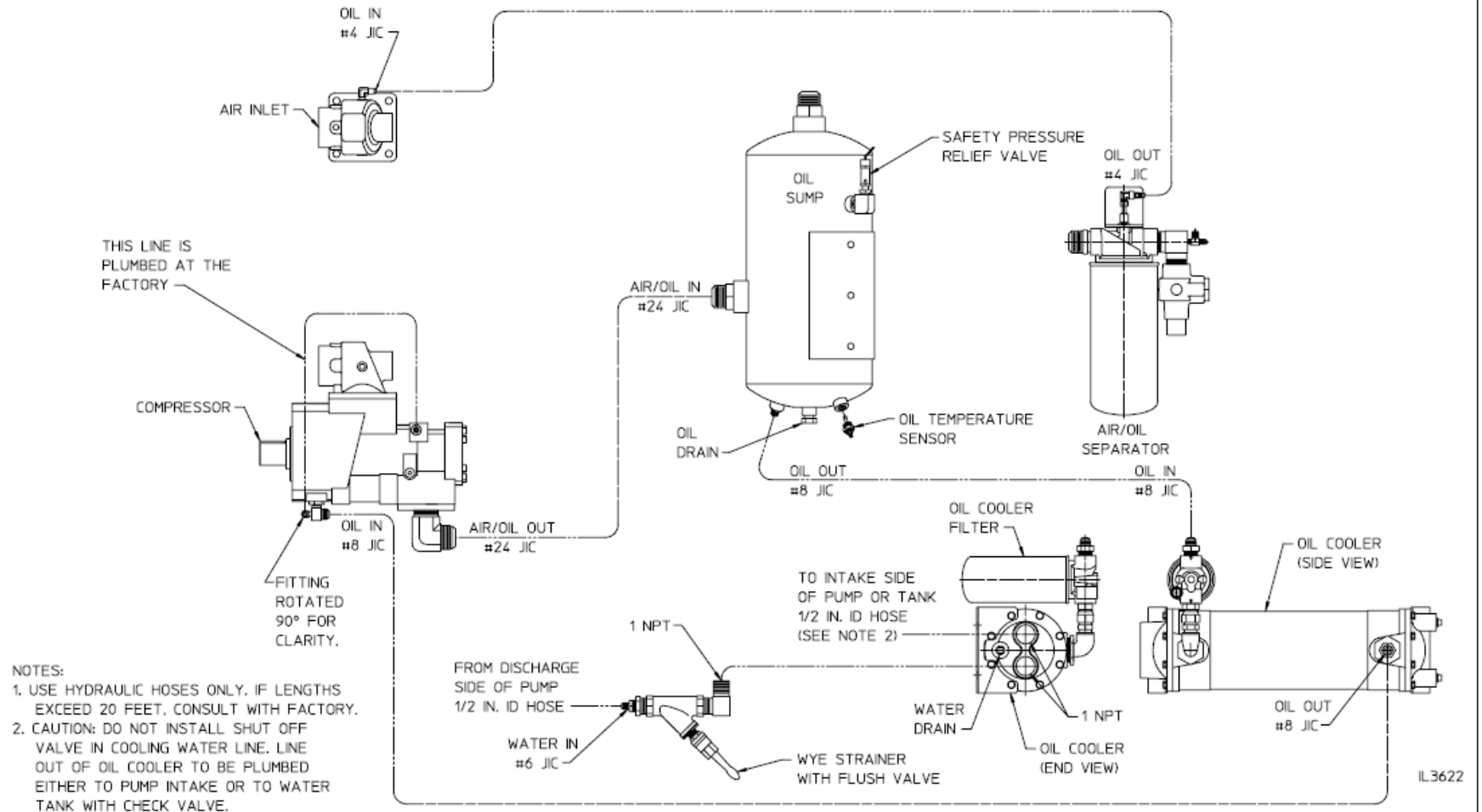

Air Filter

The air inlet on the air compressor can be turned in 90° increments because the bolt pattern is symmetrical. This simplifies installation of the air filter. If you turn the inlet, you will need longer tubing. Either acquire colored tubing locally or contact Waterous for the correct lengths and colors.

To change the rotation of the air inlet, disconnect the tubing, unbolt the inlet, rotate the inlet and install the new tubing.

Mount the air filter, considering the following factors:

- Air intake area must be unobstructed.
- Air intake tubing should be as short and straight as possible. If length exceeds 12 feet, consult the factory.
- Maintenance clearance must be adequate for removing and replacing the filter.
- The filter should be in an area that is unlikely to get wet.

The air inlet tubing (not included) from the filter to the air inlet is usually made of thin-wall metal tubing (3 in. I.D.) and rubber elbows. Plumb it as though it were an engine air inlet. Do not use flexible exhaust tubing or any material that water or dirt can easily penetrate (see Page 7 for dimensions of filter and elbow).

Air Filter Installation onto Compressor

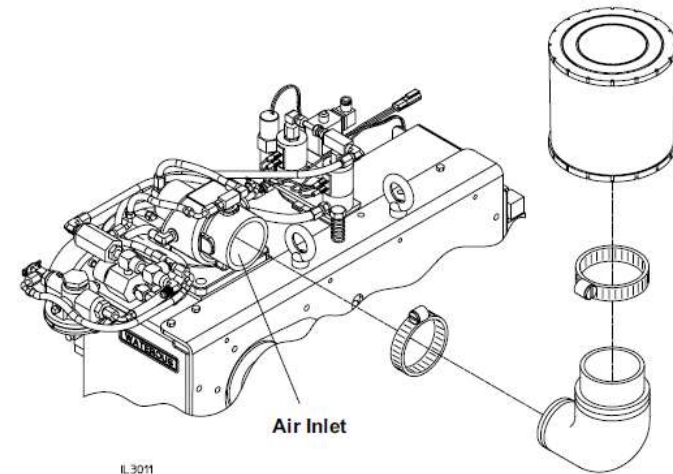

Oil Sump and Oil Temperature Sensor

NOTE: Waterous will not be responsible for systems where the sump and sight glass are installed such that the oil level cannot be checked or does not display the correct oil level due to improper installation.

NOTE: The sump must be mounted vertically.

The sump works best when it is installed so that the sight glass opening is below the discharge outlet of the air compressor, although mounting the sump at the same level as the compressor is acceptable. In some cases, finding room for the sump can be difficult. It is acceptable to mount the oil sump up to 12 inches higher than the air compressor, however, this requires the installation of a check valve to prevent oil from flooding the compressor. Contact Waterous if a check valve is required.

The **Safety Pressure Relief** valve may be installed in either of the ports. The remaining ports have no options.

Install the **Temperature Sensor** in the bottom tap of the sump next to the drain.

Vertical Sump - Rear View



Vertical Sump - Top Fittings

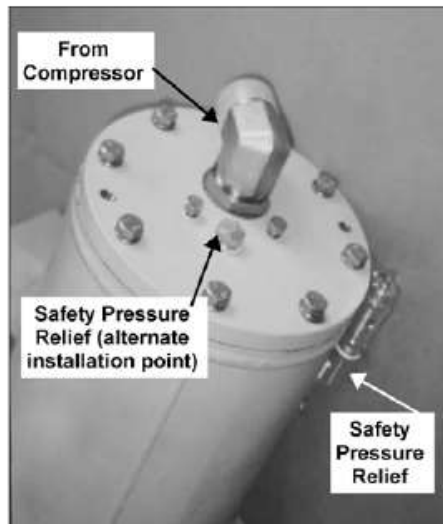

Vertical Sump - Lower Fittings

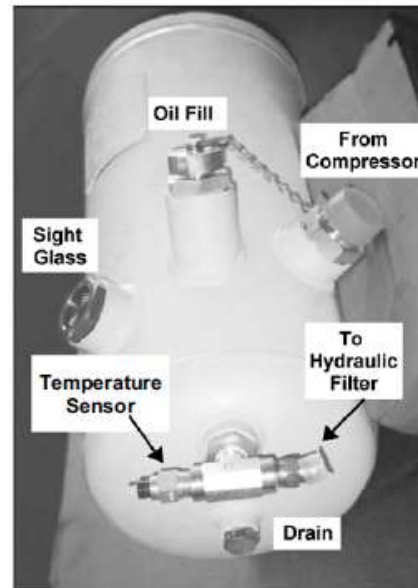

Vertical Sump - Rear View



Air / Oil Separator

The separator filter can be installed anywhere there is room to securely mount it and run the hydraulic and air lines.

- Install filter vertically with the housing up and the filter element down.
- Make sure there is room to remove and replace the filter element and the oil scavenger tube.

Separator / Filter Side View with Fittings

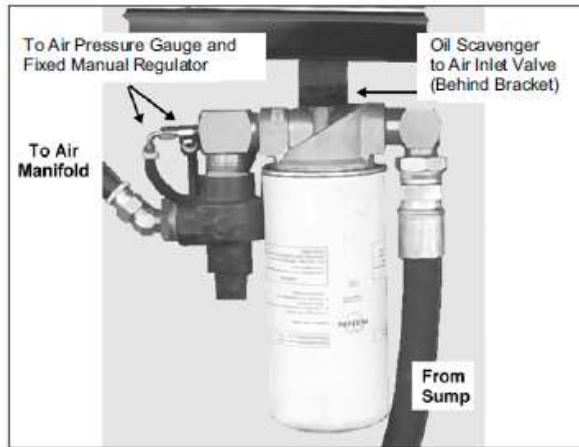

Separator / Filter and Bracket Detail

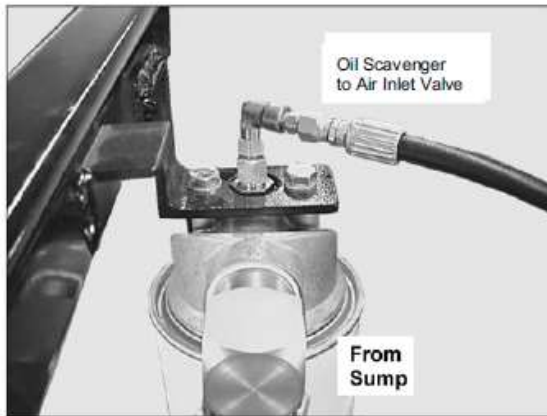

Oil Scavenger Line Connection to Compressor

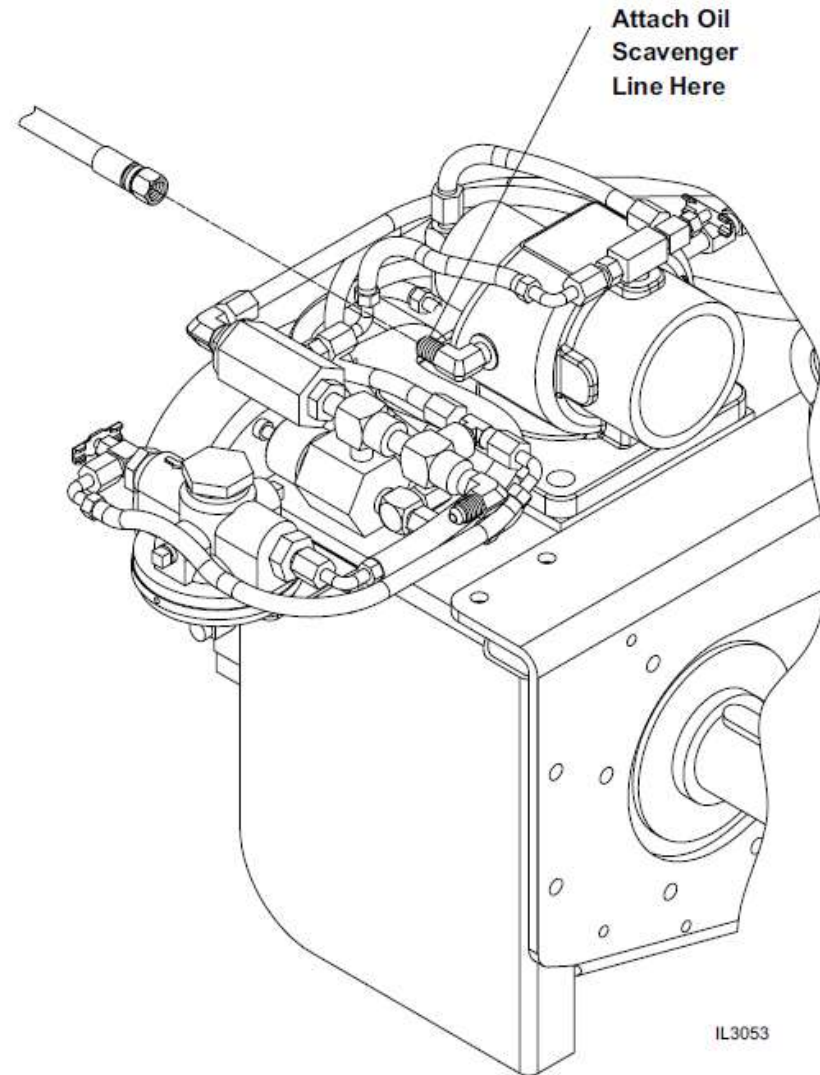

Oil Cooler

NOTICE

Do not install a shutoff valve in the oil cooler water supply. This will result in system overheat and failure and voids the manufacturer's warranty.

The oil returning to the compressor is cooled by passing it through a water-cooled heat exchanger, usually called the cooler.

Oil Inlet / Outlet Ports

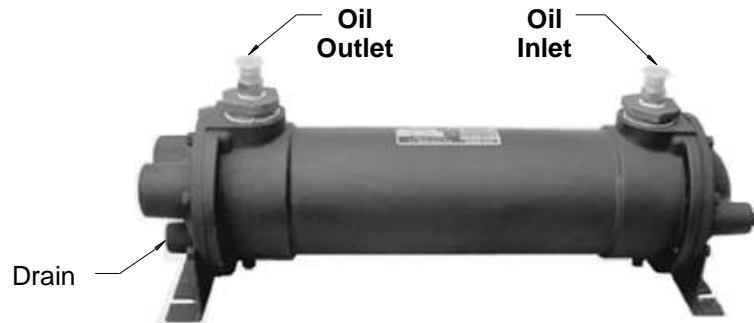

Water Inlet / Outlet Ports and Drain

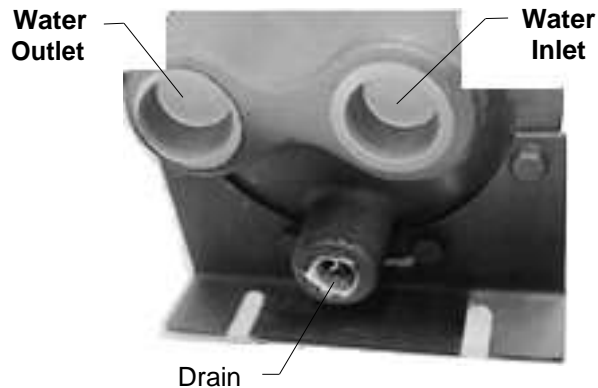

- The oil inlet and outlet may be reversed to make installation easier.
- The water inlet and outlet may be reversed to make installation easier.
- Install the cooler to allow for proper drainage to prevent freeze damage.

Freeze damage due to undrained cooler.

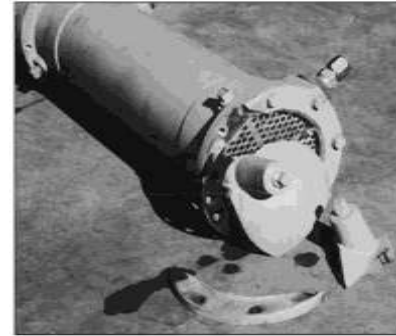

Also shows small diameter of water tubes.

- The cooler must be installed horizontally with the drain at the lowest point and with a slight slope toward the water drain end.
- The drain hose should be 0.5" I.D. minimum to provide proper drainage.
- The outlet of the drain hose must be lower than the cooler's drain outlet. The drain hose should be a continuous downward run (no goosenecks) to allow proper drainage.
- The hydraulic oil filter is mounted on the oil cooler. Make sure there is enough room for servicing the filter.
- To mount the cooler on the side of a compartment, unbolt the brackets from the ends and reattach them so the cooler can be installed with the drain at the lowest point.

Adjustable Mounting Brackets / Cooler Mounting

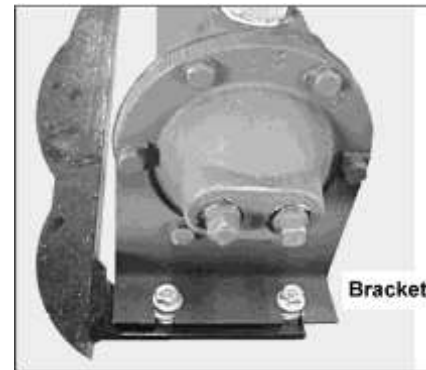

Supplied by Waterous



Cooler mounted on the side of a pump compartment with the cooler body sloping toward the drain for better drainage.

Wye-Strainer for Oil Cooler Water Line

A Wye-strainer is provided to strain water before it enters the cooler's water inlet. The Wye-strainer requires regular inspection and should be in an easily accessible location for inspection, removal and cleaning.

NOTICE

Waterous is not responsible for damage due to plugged strainers. If the customer's water system contains excessive debris or the vehicle relies on drafting for its water supply, it may be necessary to install a larger strainer.

Without good water flow through the heat exchanger, the compressor will overheat. Compressor performance will be inadequate and it may fail completely.

Omitting the Wye-strainer or removing the screen from the Wye does not improve water flow. It will allow debris into the cooler, which can clog the fine heat exchanger tubes and restrict water flow.

Connecting the Cooler Water Lines and Wye-strainer

The cooler water is supplied by diverting water through a fitting (OEM supplied) from the discharge side of the fire pump (see the **Compressor - Oil & Water Schematic, Page 8**). The cooling water supply hose should be 1/2" I.D. to supply the proper flow for cooling the system. The cooler discharge water may be routed to the booster tank fill tower or returned to the inlet side of the pump, as per the end user's preference.

Normally, cooling water is returned to the booster tank and a check valve is installed in-line to prevent backflow from the tank through the cooler. During drafting and hydrant-supplied operations, the booster tank may overflow because of the cooler water return. If this is objectionable, route the return line to the inlet side of the pump. In this case, it is not necessary to install an in-line check valve, but it will be necessary for the pump operator to open the tank fill valve during operation to prevent overheating the fire pump and compressor.

Wye-strainer Installed with Cleanout Valve and Drain Line

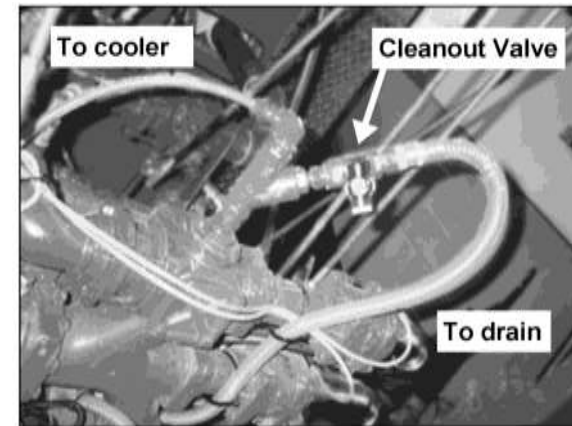

Wye-strainer with Ball Valve

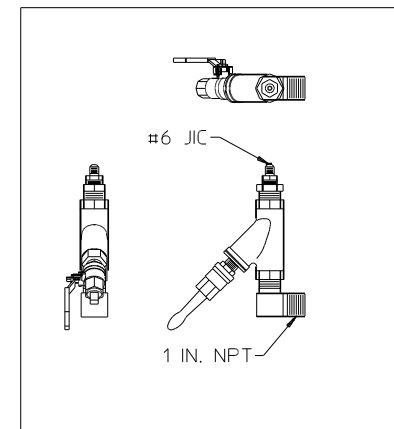

from IL3008

Compressor Panel Components

Electric Auto-Sync Panel

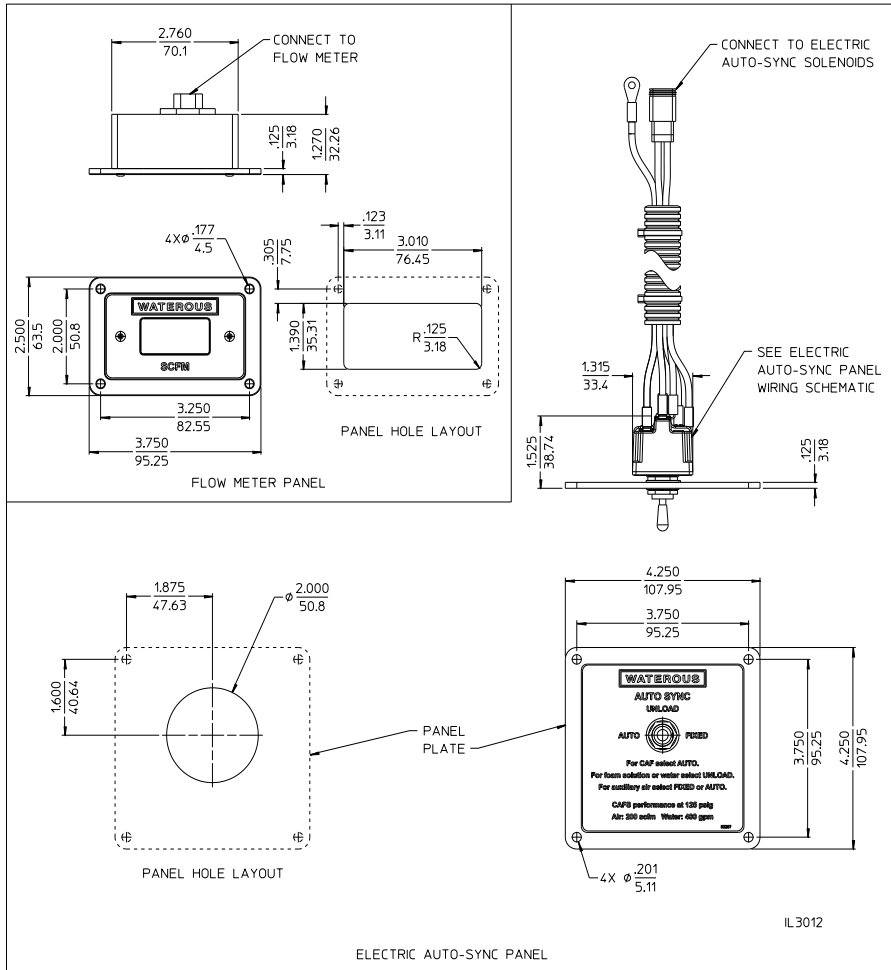

Oil Temperature Gauge

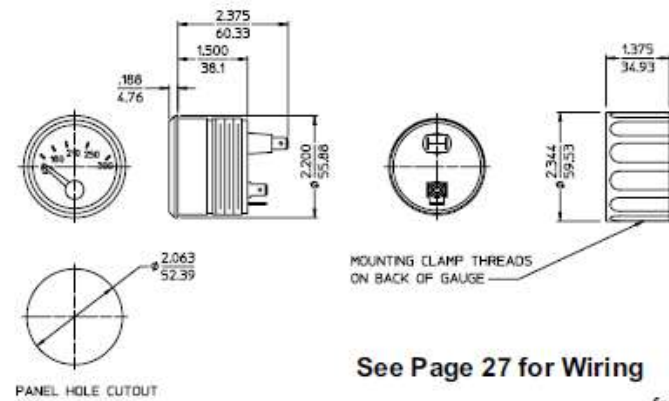

Panel Plates

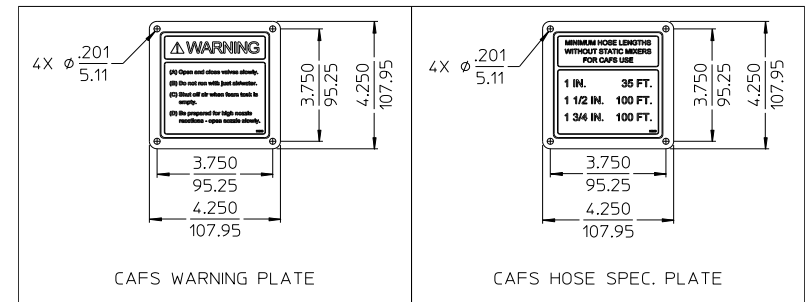

ALL DIMENSIONS SHOWN
AS INCH/MILLIMETER
($\frac{\text{INCH}}{\text{MILLIMETER}}$)

Master Air Pressure Gauge

Not Furnished by Waterous, see Page 15 for specifications.

Compressor Air Connections

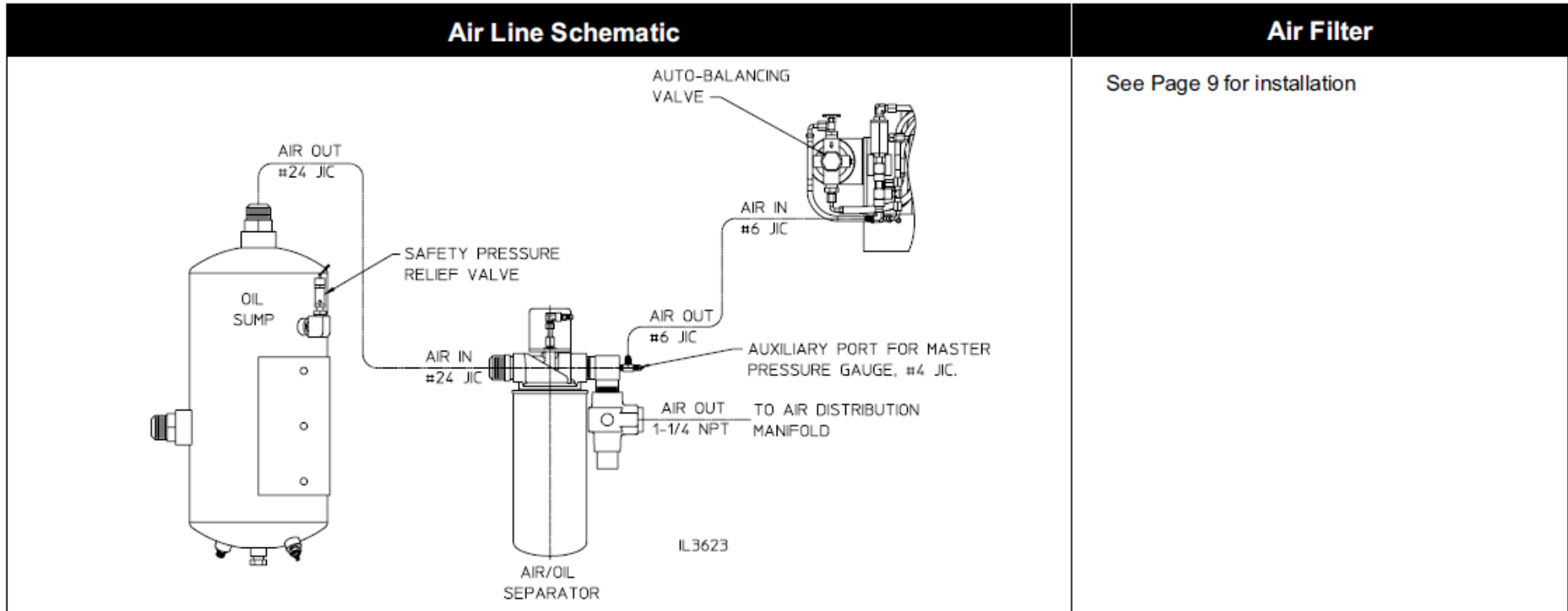

Master Air Pressure Gauge

Master Air Pressure Gauge - Not Furnished by Waterous

1. The master air pressure gauge is to be mounted on the operator's panel and be plumbed to the master air pressure tap located on the Minimum Pressure Valve (mounted on Air/Oil Separator).
2. The gauge is not furnished by Waterous and must have a 0-200 psi pressure range.
3. Air line not furnished by Waterous (see Page 29 for suggested hose size).

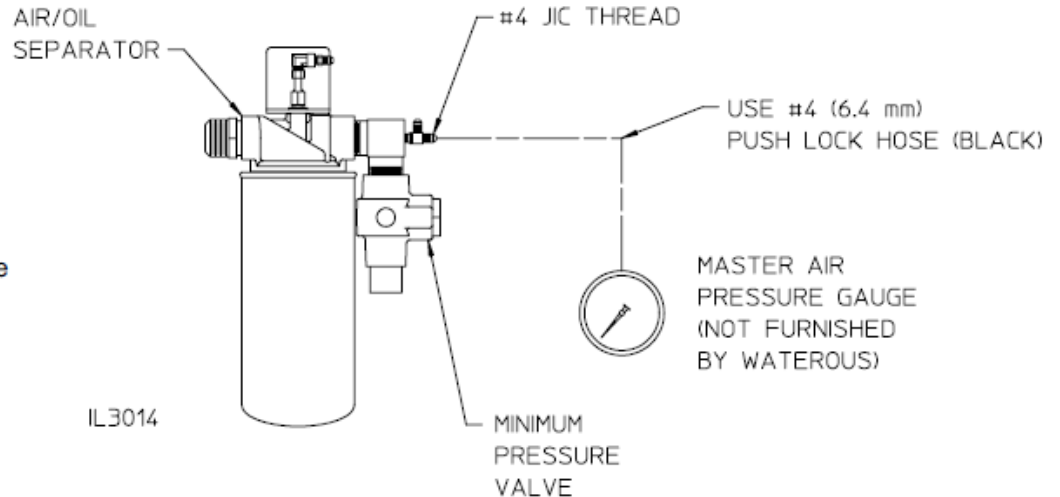

Air Clutch Connection

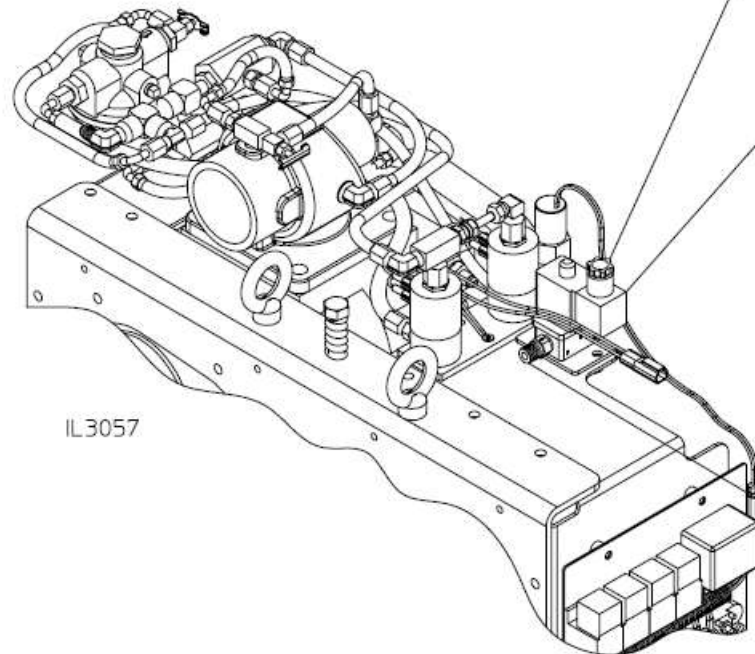
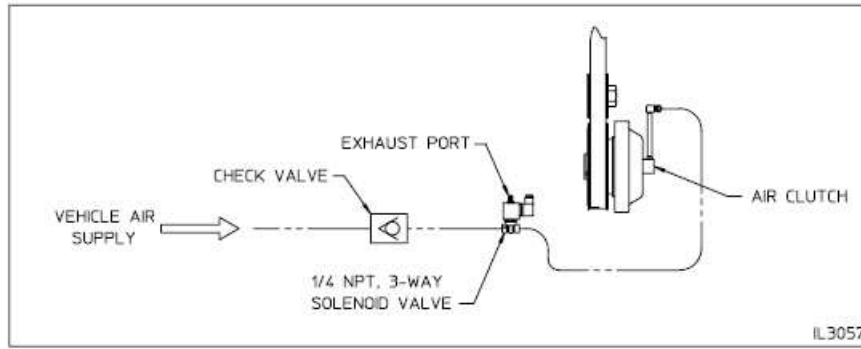

Do not block exhaust port in threaded stud.

1/4 in., 3-way Solenoid Valve,
See Page 25 for wiring and Page 21 for
switch required to activate solenoid.

Connect air lines from vehicle air system to 1/4 in. male NPT threads on check valve.

Air line not furnished by Waterous.

Air Distribution Port

Build air distribution manifold off tap in the minimum pressure valve. The minimum pressure valve is mounted on the air oil separator which is remotely mounted. Note that air distribution components are not furnished by Waterous.

See Page 30 for recommended components.

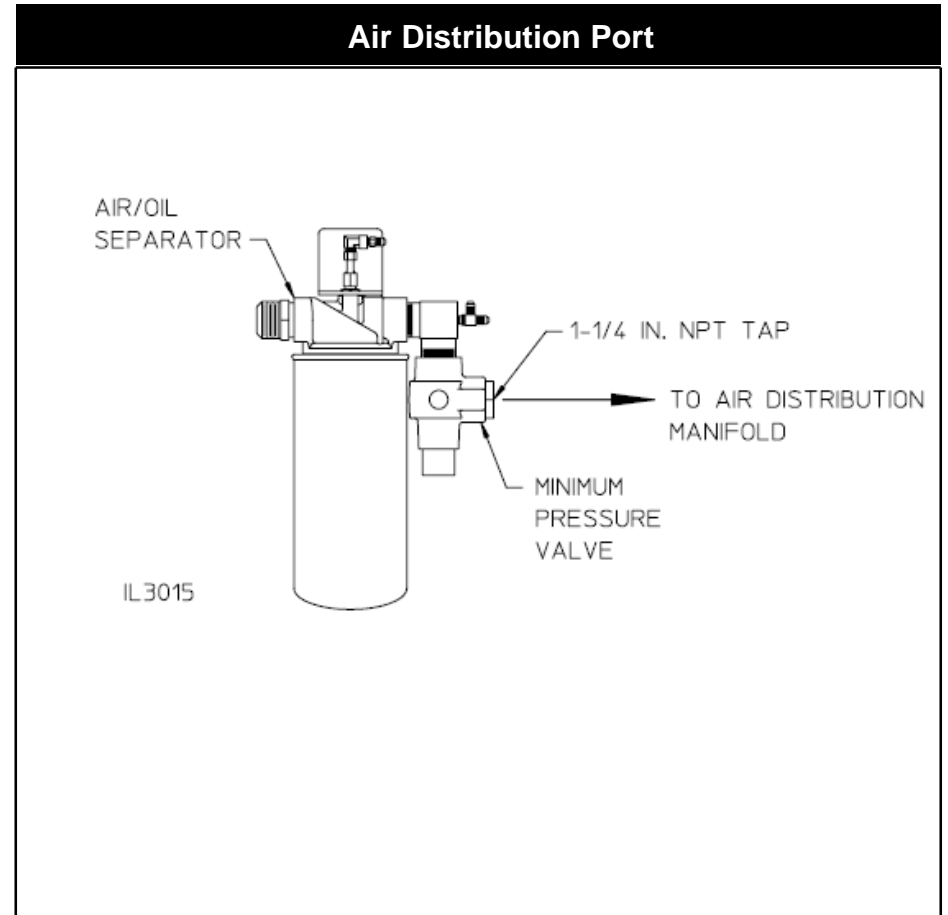

Water Drains

Oil Cooler

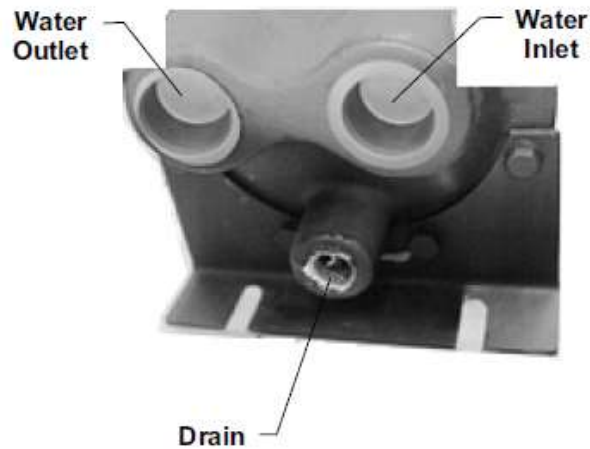

- The drain hose should be 0.5" I.D. minimum to provide proper drainage.
- The outlet of the drain hose must be lower than the cooler's drain outlet and the drain hose should be a continuous downward run (no goosenecks) to allow proper drainage.

Fire Pump

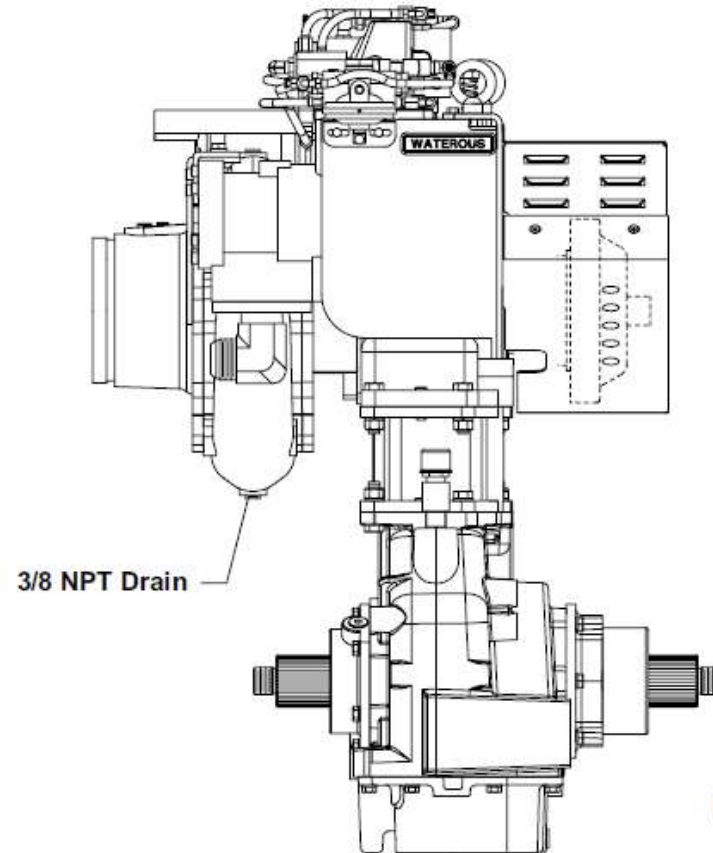

Also refer to F-1031, Section 3012, *Drain Valve Installation*

Foam System

Refer to Foam System Installation Instructions for Foam System drains.

Lubrication

Pump Transmission

Add any type of automatic transmission fluid (ATF) through the oil level/fill hole or by removing the breather. Approximately 6 quarts is required to fill the transmission when completely drained. Fill to the bottom of "Oil Level" port threads.

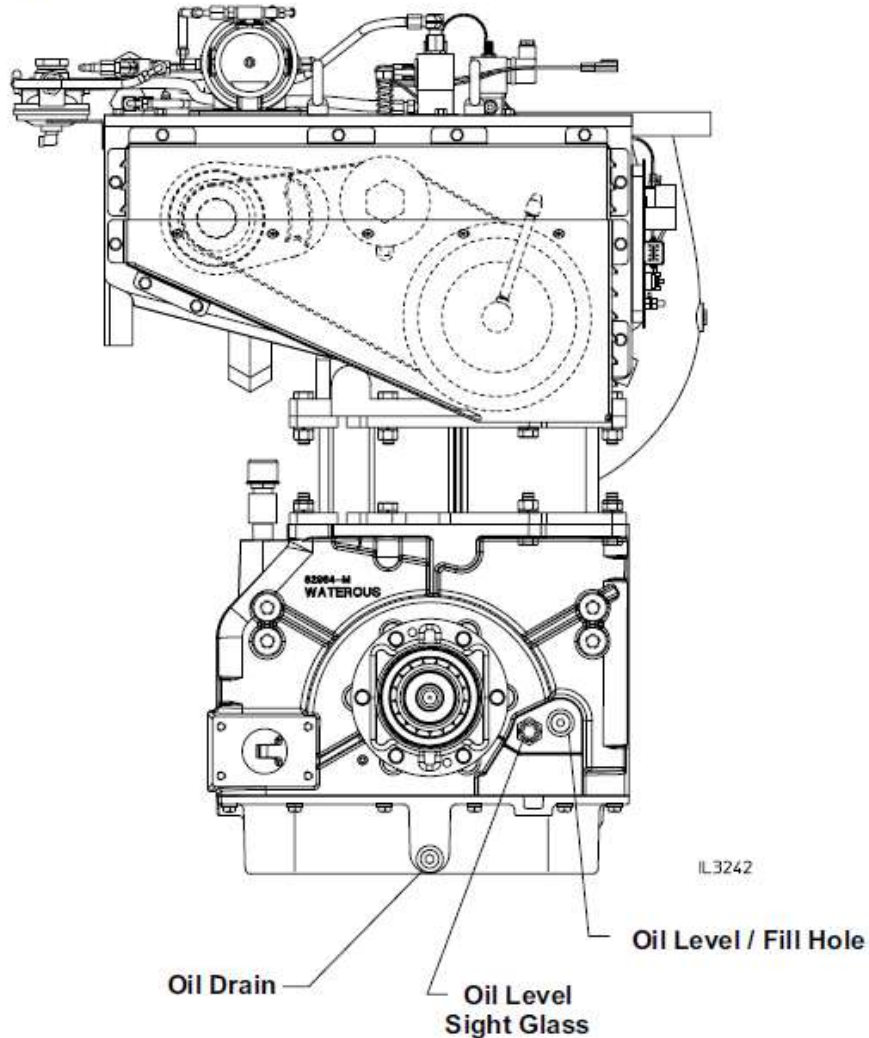

Air Compressor

There is a sight glass provided on the oil reservoir/sump tank. The oil level should be approximately half-way up the window. Check the oil on level ground prior to system start-up (system holds approximately 2 to 3 gallons of oil).

If the system has recently been run, wait 10 minutes after shut-down for the oil to stabilize before checking the oil level.

The compressor uses a common non-foaming hydraulic oil. This oil is classified by an ISO standard as ISO 68 viscosity and is sold under various trade names. Many are sold as an "anti-wear" hydraulic oil and are available from auto parts or lubricating oil supplies.

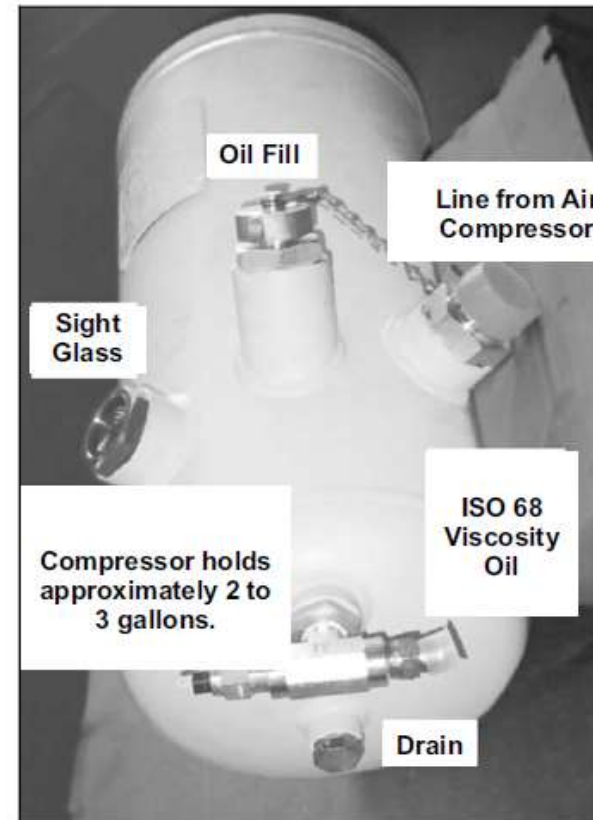

Electrical Wiring

Compressor Wiring Schematic

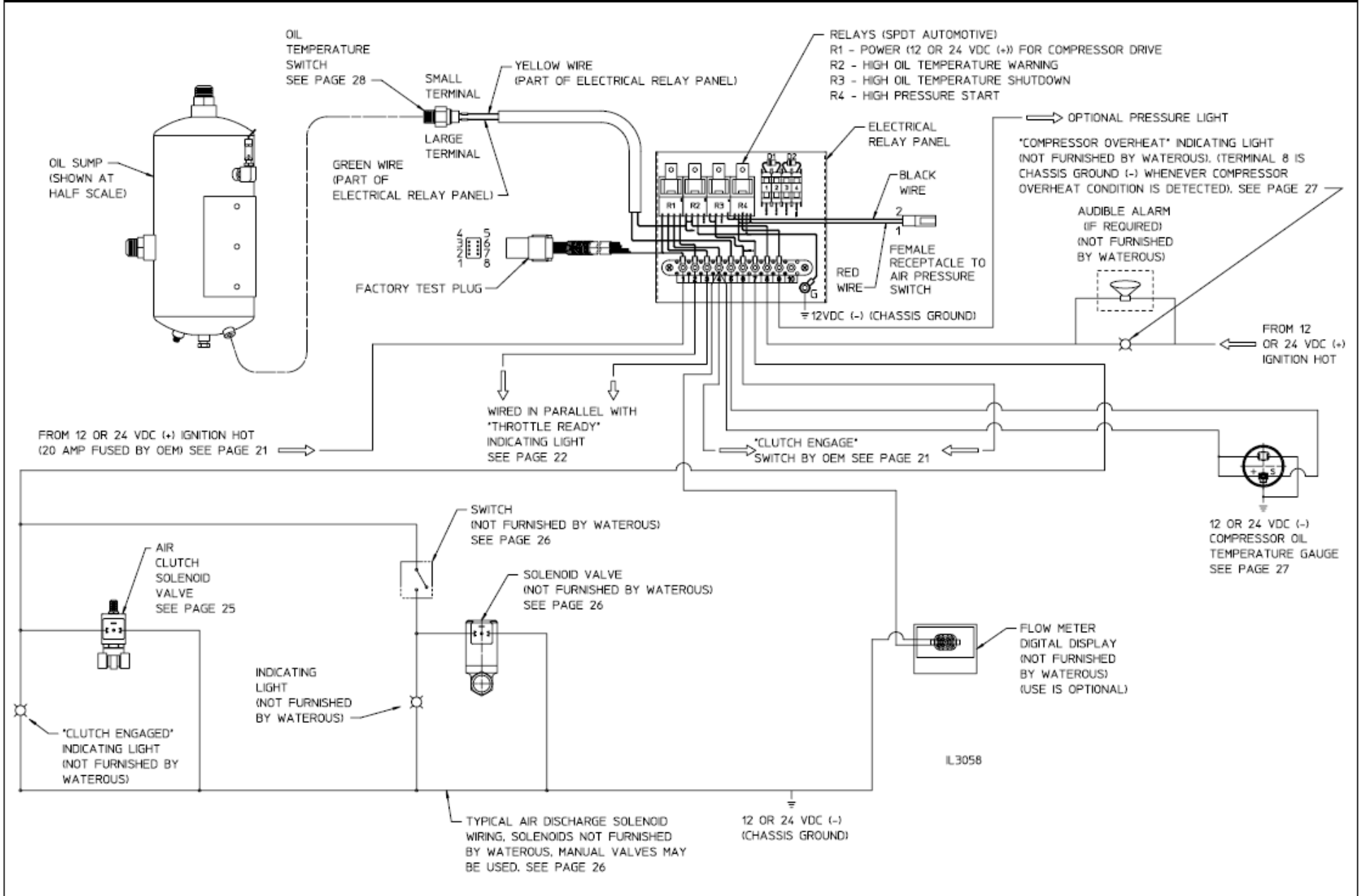

Power to Compressor Relay Panel

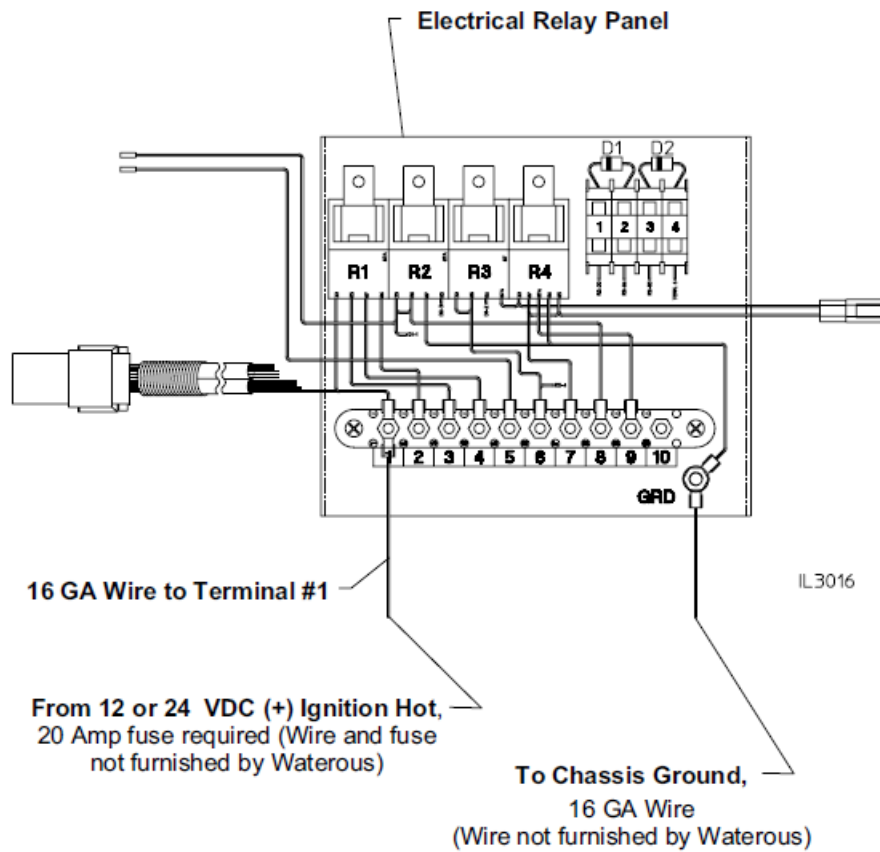

Air Clutch Engage Switch

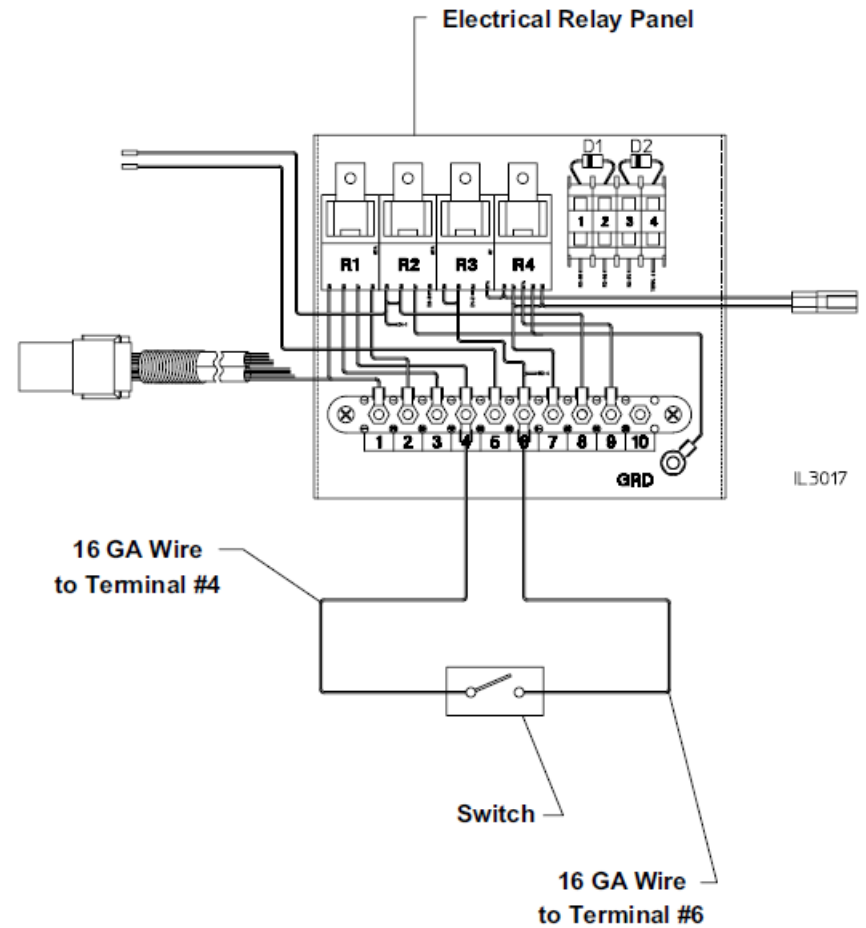

NOTE: Wire and switch not furnished by Waterous.

"Throttle Ready" Interlock Loop

To prevent the Eclipse ES from being engaged while the vehicle is in the ROAD mode, terminals #2 and #3 are provided for a Throttle Ready interlock loop. When the Throttle Ready light is on, power is supplied to the "Clutch Engage Switch." Note that the "Throttle Ready" indicating light must be illuminated before the Eclipse ES unit can operate.

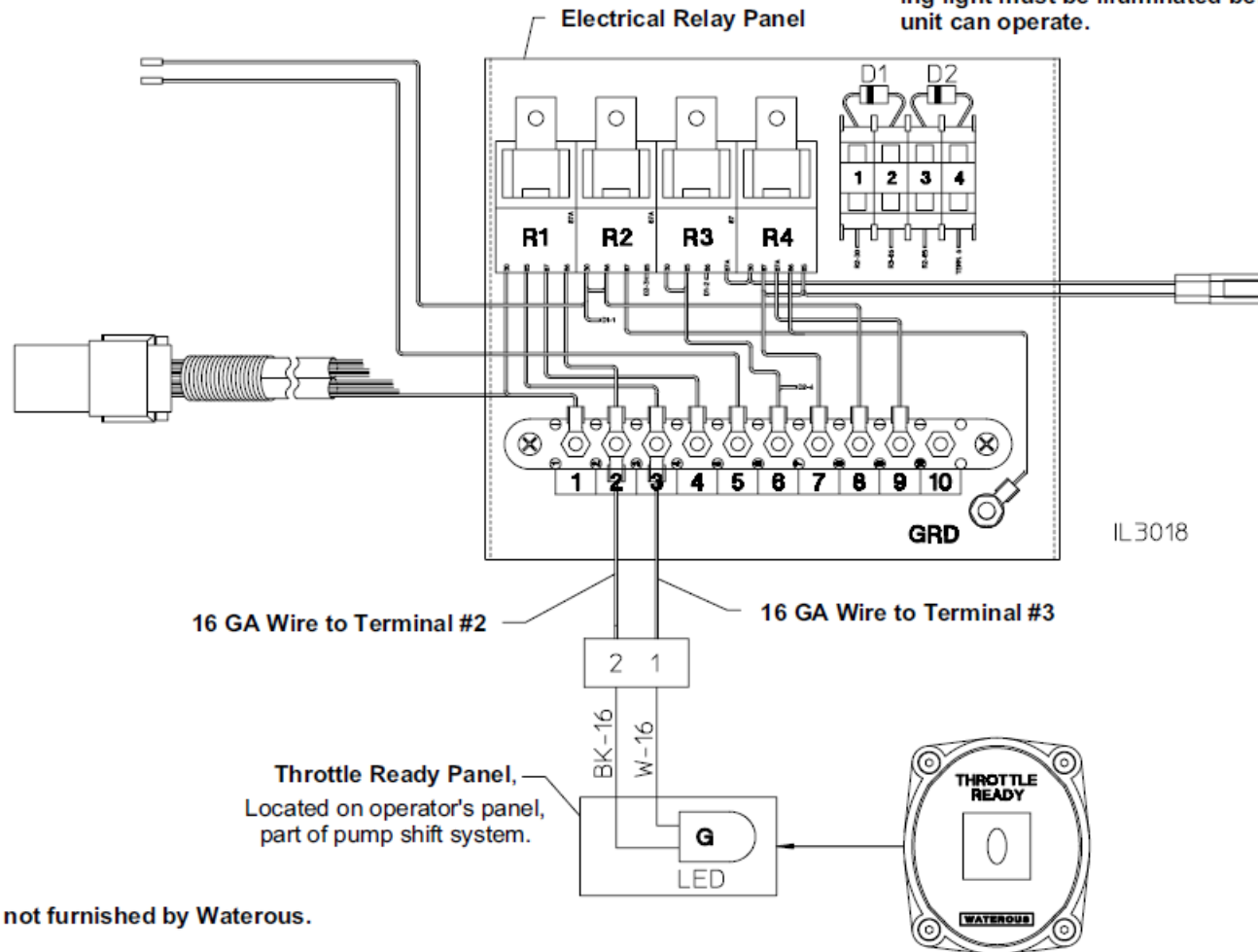

NOTE: Wire not furnished by Waterous.

Electric Auto-Sync Panel – Wiring to Relay Panel

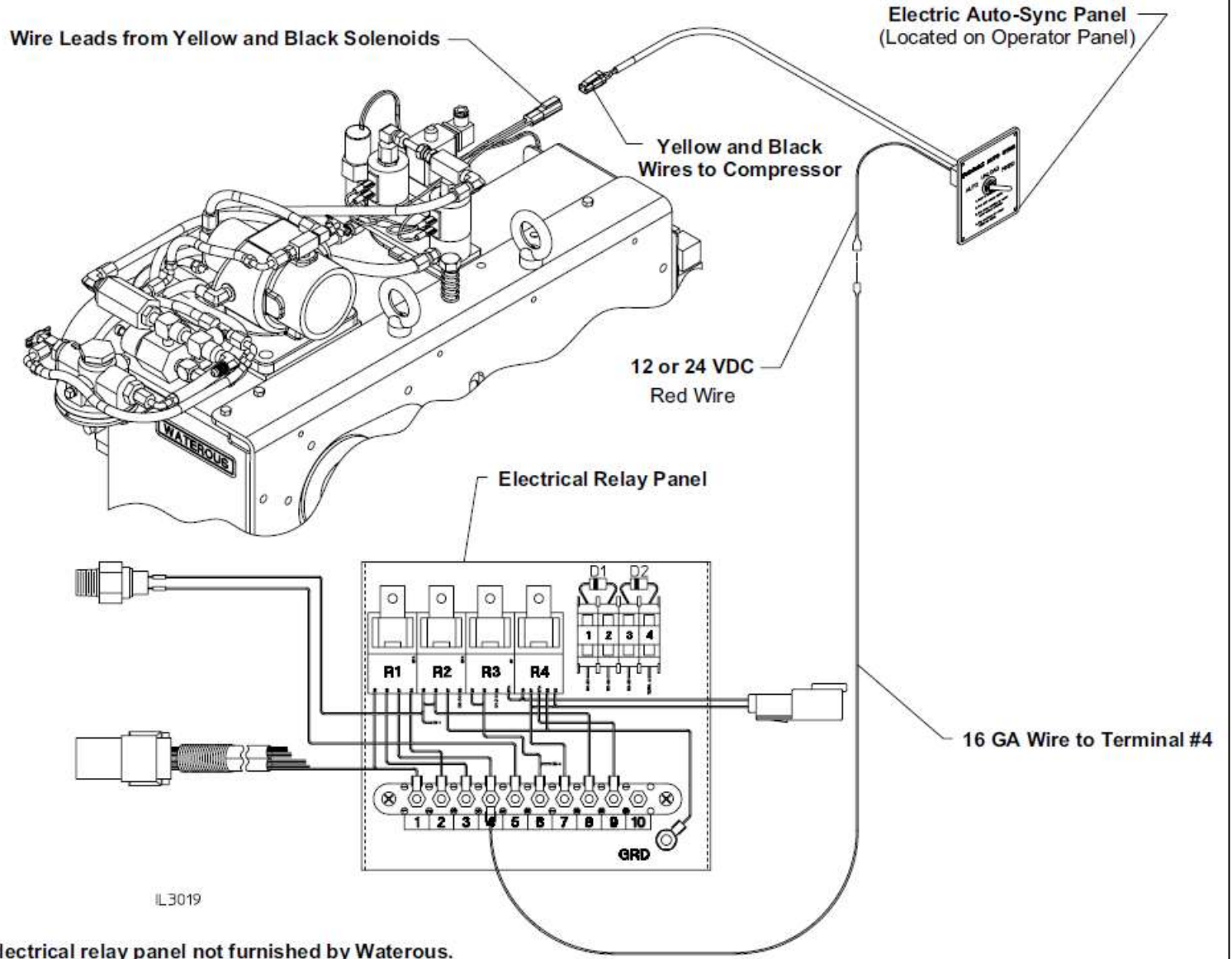

Air Clutch Solenoid - See Page 16 for Location

1. Wire the switch to +12 or 24 VDC from Terminal #7.
2. Wire the indicating light in parallel with the solenoid.

NOTE: Wire and light not furnished by Waterous.

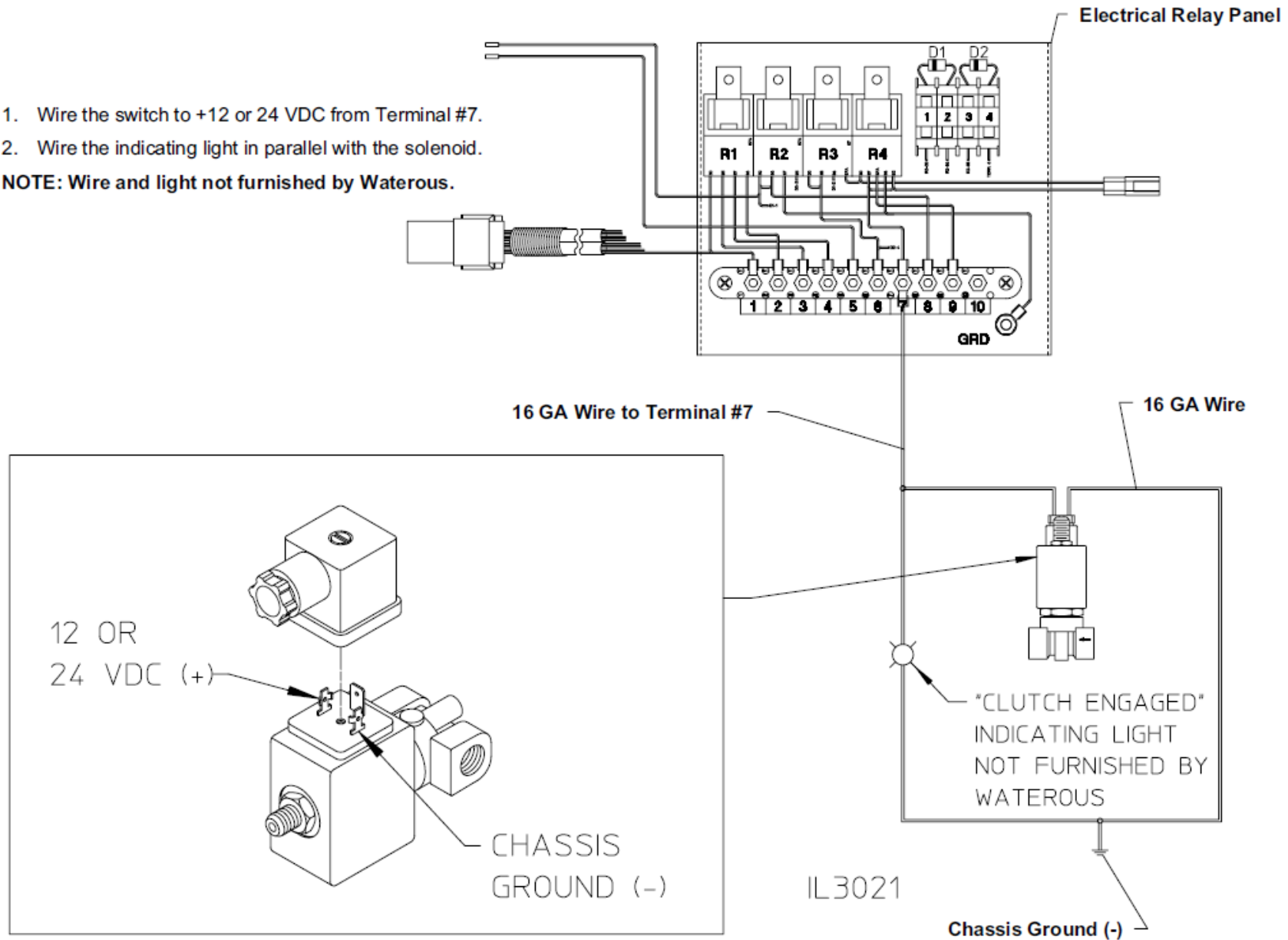

Air Discharge Solenoids

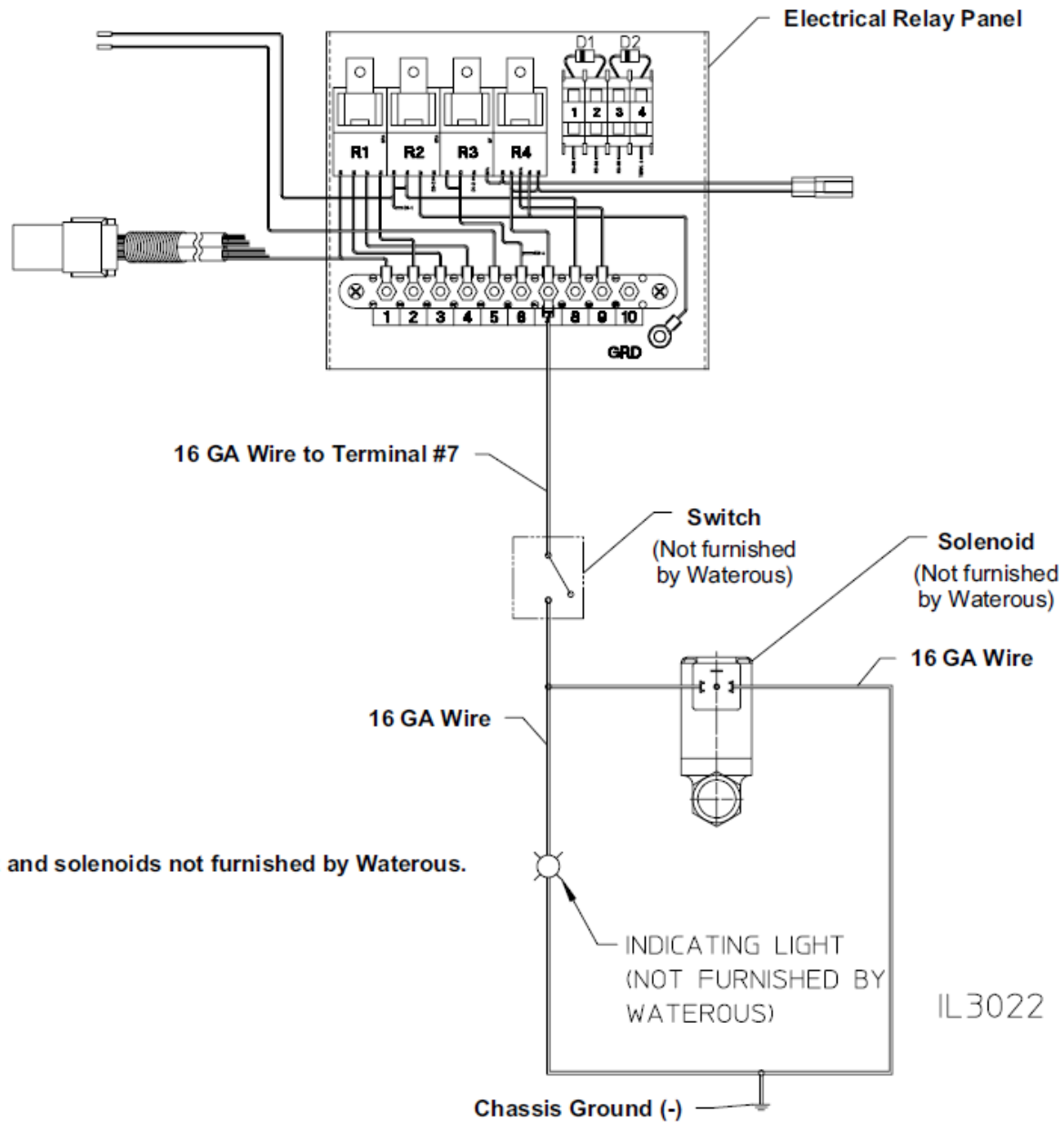

NOTE: Wire, switches, light and solenoids not furnished by Waterous.

Compressor Overheat Light and Optional Audible Alarm

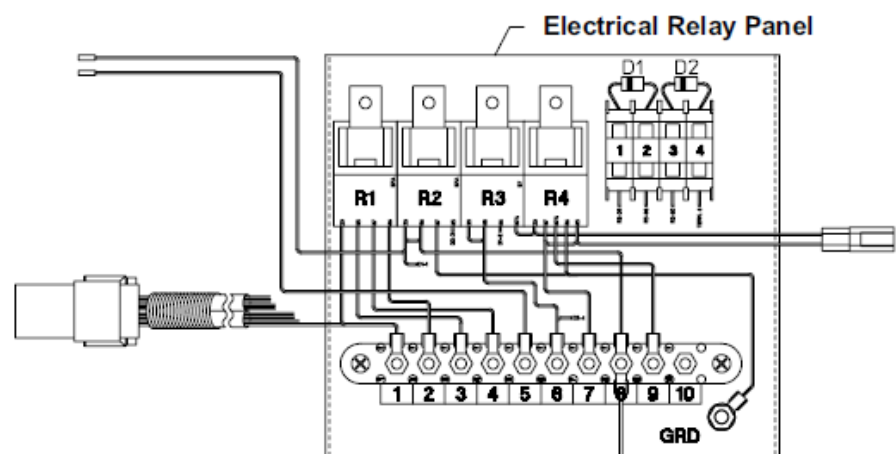

16 GA Wire to Terminal #8

NOTE: Wires, light and alarm not furnished by Waterous.

Optional Audible Alarm

IL3023

"Compressor Overheat" Indicating Light,

Terminal #8 is chassis ground (-) whenever compressor overheat condition is detected.

Compressor Oil Temperature Gauge

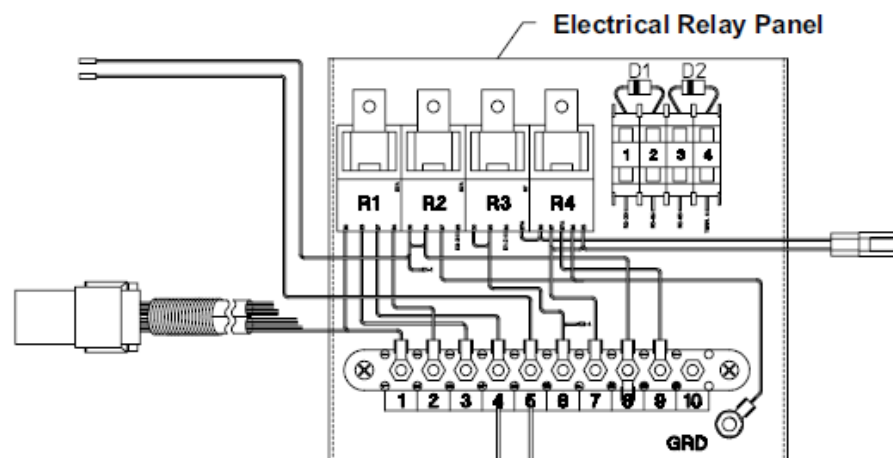

16 GA Wire to Terminal #4

IL3024

16 GA Wire

16 GA Wire to Terminal #5

NOTE: Wire and switch not furnished by Waterous. Gauge furnished, to be mounted on operator's panel.

Oil Temperature Sensor

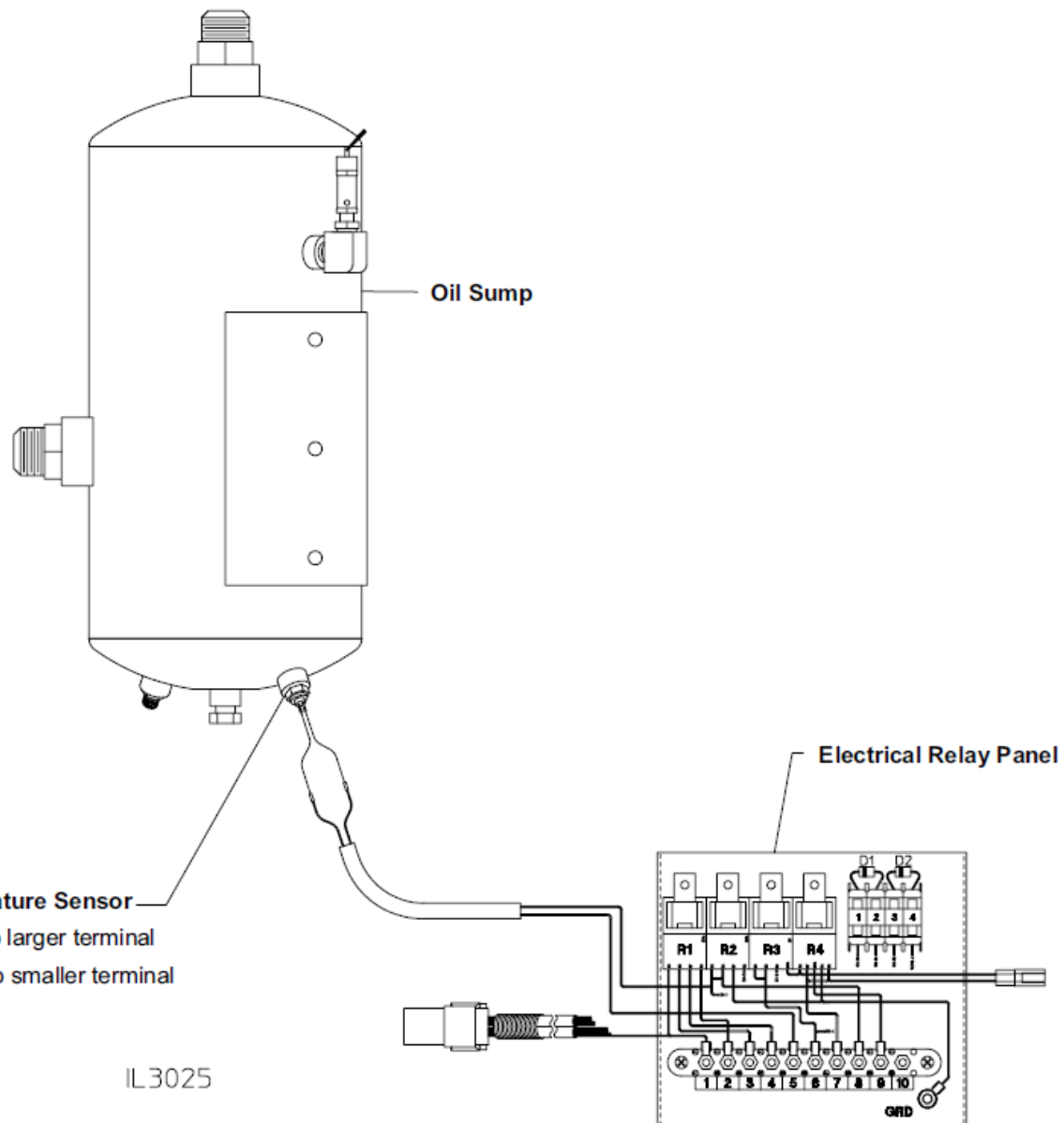

Suggested Third-Party Components

NOTE: These guidelines are useful for many installations but selection of third-party components is at the discretion of the system installer or vehicle manufacturer.

Air Flow Meter

Use of an air flow meter is optional.

Master Air Pressure Gauge (See Page 15)

When selecting a master air pressure gauge, make sure it has a pressure range of 0-200 psi.

Air Lines Between Components (See Page 15)

Refer to "Suggested Air Hose" specifications on this page.

Hydraulic Lines Between Components (See Page 8)

The base hydraulic hose size will be the same as the fitting hose connected to. For example; Use 3/8 in. hose for a #6 (3/8 in.) JIC fitting. Note that hydraulic lines should be as short as possible and individual hoses should not exceed 20 feet in length.

CAFS Discharge Components

The installer must provide fittings and tubing to connect CAFS components to the vehicle's discharge outlets. These are **suggested parts** for common discharge sizes. If the planned discharge system is not covered in this guideline, please contact Waterous.

NOTE: Waterous strongly suggest that every CAFS discharge have an air check valve and water check valve as shown below. The air check valve prevents foam solution from backflowing into the compressor and contaminating the oil. The water check valve isolates the discharge, preventing CAF from backflowing into the foam solution manifold and exiting through another discharge. This makes it possible to flow solution through one discharge and CAF through another.

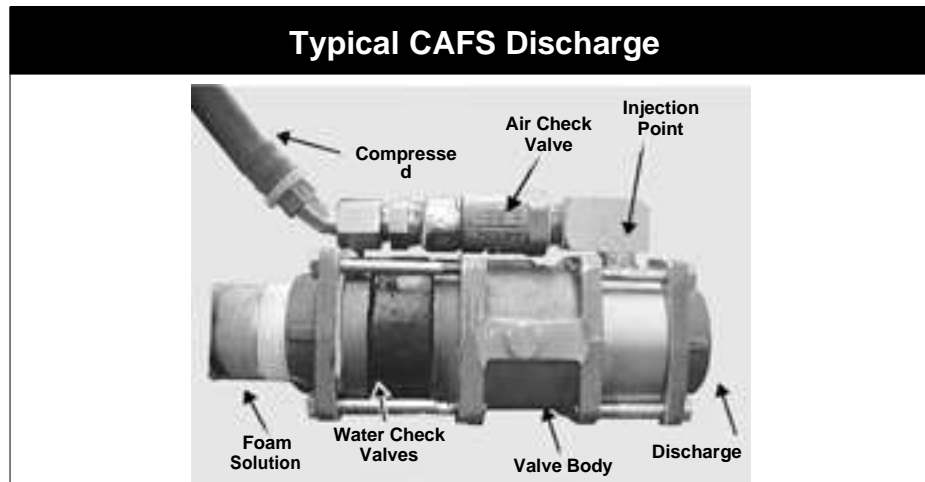

Suggested Air Hose

The interior diameter (I.D.) of the hose is the most important factor and any hose with the correct I.D. and rated to withstand the expected air system pressure (500 PSIG burst pressure) may be used.

The most cost-effective hose is a push-on type hose (Weatherhead H101 or H201 or equivalent). Hoses come in a variety of colors for color-coding the lines by purpose.

The other type of hose that is commonly used for air discharges is hydraulic hose, SAE 100R1 type. Typically, hydraulic hose is not necessary on the air discharge circuit due to the system air pressure not exceeding 150 psi.

Air brake hose may also be used, provided the inside diameters are correct:

Air Brake Hose O.D. / I.D. Dimensions	
O.D. (Inches)	I.D. (Inches)
.375	.250
.500	.375
.625	.500
.750	.625

Discharge Fittings

Suggested for 1" Booster Reel or 1" Remote Discharge (Use 3/8" Air Hose)

Quantity	Description
1	Water Check Valve (same size as discharge valve - suggest ball & cone style)
1	12 BV Class 1 Valve
Quantity	Fittings Per Discharge
4	#6 JIC x 6 Push-Lock
2	#6 JIC x 1/2" NPT-M 90
1	3/4" NPT-M x 1/2" NPT-F Bushing
1	#6 JIC x 1/2" NPT-M
1	3/4" NPT Nipple
1	1/2" Air Check Valve

If an electric solenoid valve is used for air instead of a manual valve, use:

- 1/2" direct-acting solenoid valve
- Toggle switch SPST (suggest switch guard)
- 1/2" x 3/8" NPT bushing
- #6 x 3/8" Female 37 JIC swivel to NPT-M adapter
- Delete #6 JIC x 6 Push-Lock
- Delete #6 JIC x 1/2" NPT-M 90

Suggested for 1-1/2" and 2" Discharges - Use 1/2" Air Hose

Quantity	Description
1	Water Check Valve (wafer, flange or ball & cone style - same size as discharge)
1	12 BV Class 1 Valve
Quantity	Fittings Per Discharge
4	#8 JIC x 8 Push-Lock
2	#8 JIC x 1/2" NPT-M 90
1	#8 JIC x 3/4" NPT-M
1	3/4" NPT Nipple
1	3/4" Air Check Valve

If an electric solenoid valve is used for air instead of a manual valve, use:

- 1/2" direct-acting solenoid valve
- Toggle switch SPST (suggest switch guard)
- #8 x 1/2" Female 37 JIC swivel to NPT-M adapter
- Delete #8 JIC x 8 Push-Lock
- Delete #8 JIC x 1/2" NPT-M 90

Suggested for 2-1/2" Discharges - Use 3/4" Air Hose

Quantity	Description
1	Water Check Valve (wafer, flange or ball & cone style - same size as discharge)
1	34 BV90 Class 1 Valve
Quantity	Fittings Per Discharge
4	#12 JIC x 12 Push-Lock
2	#12 JIC x 1/2" NPT-M 90
1	#12 JIC x 3/4" NPT-M
1	3/4" NPT Nipple
1	3/4" Air Check Valve

If an electric solenoid valve is used for air instead of a manual valve, use:

- 1/2" or 3/4" direct-acting solenoid valve
- Toggle switch SPST (suggest switch guard)
- Proper size adapter
- If 1/2" valve, use #8 x 1/2" Female 37 JIC swivel to NPT-M adapter
- If 3/4" valve, use #12 x 3/4" Female 37 JIC swivel to NPT-M adapter
- Delete #12 JIC x 12 Push-Lock
- Delete #12 JIC x 1/2" NPT-M 90

Suggested Fittings for Auxiliary Air Outlet - Use 3/8" Air Hose

Quantity	Description
1	38 BV Class 1 Valve
1	Class 1 #102089 Gauge Test Plug for Auxiliary Air
Quantity	Fittings Per Discharge
4	#6 JIC x 6 Push-Lock
2	#6 JIC x 1/2" NPT-M 90
1	#6 JIC x 1/4" NPT-M

NOTE: Fittings on all hoses should be 37 JIC.

Air Distribution Manifold

Waterous suggests NPT fittings with the appropriate number and size ports, however, the manifold can be built with air brake tubing if strict attention is paid to the inside diameters:

Air Brake Hose O.D. / I.D. Dimensions	
O.D. (Inches)	I.D. (Inches)
.375	.250
.500	.375
.625	.500
.750	.625

Initial Power-Up

Post-Installation, Pre-Power-Up Safety Check

Before powering up the CAFSystem, perform the following:

1. Remove all tools, shop towels, hose trimmings and other debris from the compartments.
2. Double check all hydraulic, air and water lines against the schematics, testing to make sure each connection is tight and that the hose is fully inserted into the fitting.
3. Check all of the unused inlets: plastic shipping caps must be removed and replaced with the appropriate plug or cap.
4. Make sure all drain valves are closed.
5. Make sure the gauges are connected to the appropriate sender (temperature, pressure, etc.)

6. Fill the sump with specified hydraulic oil until the oil level is 1/2 way up the sight glass. You will need to add more oil later to compensate for the oil that remains in the hydraulic lines and the compressor.

NOTE: Oil used in the system is ISO 68 hydraulic oil. It must be "Low-foaming" or "Anti-foam".

7. Make sure the foam proportioner is operating properly (see manufacturer's installation guide).
8. Make sure the fire pump is operating properly and that water flows through the oil cooler.
9. Make sure the connection between the compressor drive shaft and the PTO is secure and that the driveline angles match.

Initial Compressor System Power-Up



WARNING

Compressed Air Pressure Hazard. May result in personal injury.

Compressed air can be dangerous. Make sure the pressure is allowed to bleed down to atmospheric pressure prior to opening any connections or valves.

1. Remove the inlet valve and pour 8 to 16 ounces of hydraulic oil into the air inlet of the compressor.
2. Replace the inlet valve.
3. Place the Auto-Sync system in UNLOAD and AUTO (UNLOAD for electric Auto-Sync).
4. Start the vehicle's engine and engage the PTO.
5. With the system powered up, turn the Auto-Sync to the RUN/FIXED positions (FIXED for electric Auto-Sync). Air pressure should rise to about 110 psi.
6. Check for leaks by listening for hissing noises at the fittings.
7. Shut the PTO off, allow the pressure to bleed off, then add oil to the sump to bring the oil level 1/2 way up the sight glass.
8. Proceed to "Calibration".

Control Air Circuit Schematic

COMPRESSOR MODE	BLACK SOLENOID NORMALLY OPEN	YELLOW SOLENOID NORMALLY OPEN
UNLOAD	NOT ENERGIZED: OPEN	NOT ENERGIZED: OPEN
FIXED	ENERGIZED: CLOSED	ENERGIZED: CLOSED
AUTO	ENERGIZED: CLOSED	NOT ENERGIZED: OPEN

NOTE: For an explanation of Control Air Circuit functions, see Operation and Maintenance Instructions F-1031, Section 2119.

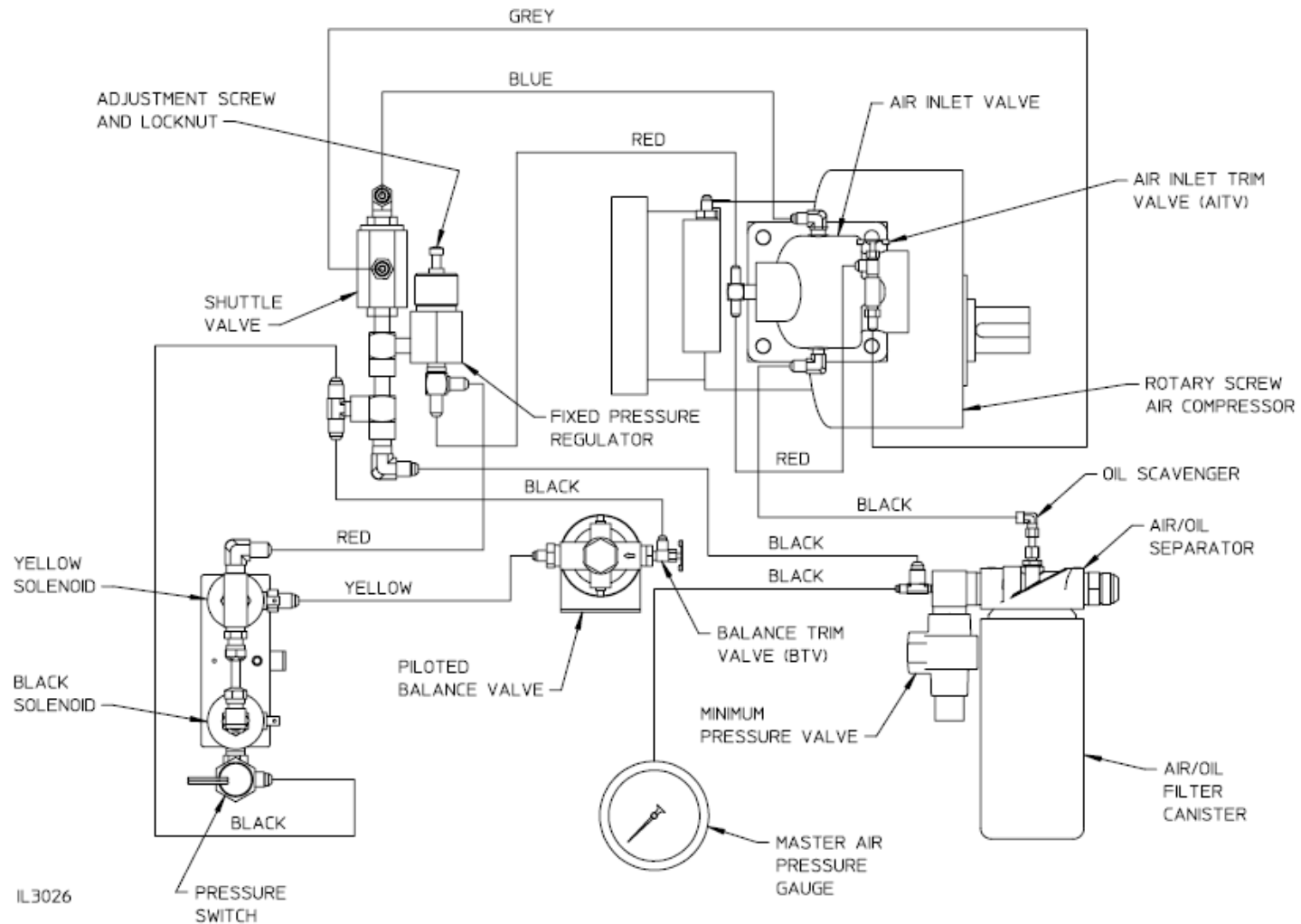

IL3026

Electric Auto-Sync System

The Electric Auto-Sync System seldom needs adjusting after the initial setup provided the rest of the CAFS system is well maintained.

NOTE: Do not adjust the Electric Auto-Sync components to compensate for problems elsewhere in the CAFS system.

NOTE: Before making any adjustments, check the following items:

- Check the oil level in the sump for proper level
- Check the air and oil filters for their scheduled servicing
- Check the oil change date
- Check the compressor for overheating
- Check the cleanliness of the oil cooler strainer
- Check air lines for leaks

Control Air Circuit Calibration - See Next Page for Location of Components

The Eclipse_M ES Air Control circuit is preset and adjusted at the factory prior to shipment. In most cases, the factory settings will provide satisfactory performance for typical CAFS and auxiliary air applications. The FIXED air operation is factory set at 145-150 P.S.I.G. The AUTO air operation is set (or trimmed) to match the fire pump discharge pressure (+/- 5%).

If the air control circuit requires changing or the circuit has lost its factory setting, the following procedure can be used to "fine tune" the system.

1. Preset the Air Inlet Trim Valve (AITV) by closing the valve, then opening the valve three complete turns.
2. Preset the Balance Trim Valve (BTV) to full open.
3. Start the fire pump, remaining at idle speed, and establish water flow either through a discharge or tank recirculation.
4. Set the Auto Sync Control Panel to UNLOAD mode and close all discharges.
5. Start the air compressor by placing the compressor engage switch to "ON".
6. Read the main air pressure gauge (should read 40-50 P.S.I.G.). In the UNLOAD mode, this minimum pressure is always present to provide compressor oil circulation.

Final Adjustments for the FIXED and AUTO Modes

FIXED Air Mode

1. Locate the Fixed Pressure Regulator. Note that the regulator has an adjustment screw with a lock nut.
2. Loosen the regulator's lock nut.
3. Place the controls to FIXED position on the Auto Sync Panel. The compressor will build pressure to some value and hold (regulate).
4. Adjust the screw on the Fixed Pressure Regulator, while monitoring the air pressure gauge, until the desired pressure is reached. Turning the screw

NOTE: Always start by adjusting UNLOAD mode, then FIXED and then AUTO.

A common problem is unauthorized adjustment of the balance valve in an attempt to improve performance.

If unauthorized adjustments to the Electric Auto-Sync are a problem we suggest placing a seal over the adjustment points. This will let maintenance personnel know if the system has been tampered with.

in will INCREASE the pressure. Turning the screw out will DECREASE the pressure.

AUTO Air Mode

1. Place the Auto Sync controls to the AUTO position with the fire pump operating at 100 P.S.I.G. main discharge and minimal flow.
2. Monitor main water discharge pressure gauge and the air pressure gauge. The pressure readings should be the same. If not, go to Step 3.

Air Inlet Trim Valve (AITV)

3. Close the trim valve in half turn increments if the air pressure is too high. Monitor both water and air pressure gauges until the pressures match. Once the pressures match, no further adjustments are needed and go to Step 5. If the air pressure is too low, open the trim valve a half turn then check water and air pressure gauges. If the air pressure is still too low, open the trim valve a half turn. If the air pressures match, no further adjustments are needed and go to Step 5. However, if your air pressure is still too low, go to Step 4.

Note that the Air Inlet Trim Valve is now four turns open from fully closed. It is not desirable to have the trim valve open more than four turns. To extend the trim valve's range, use the Balance Trim Valve (BTV).

4. Close the BTV one turn from the fully open position. Check the water and air pressure gauges. If the air is still too low, again close the BTV one turn and check the gauges. Keep repeating the process until the air pressure matches or is slightly higher than the water pressure. The final adjustment can be done using the AITV and Step 3.
5. Verify the piloted balance valve is performing by varying the fire pump discharge pressure and monitoring the water and air pressure gauges. The air pressure should follow and match the water pressure. If not, repeat the final adjustment procedure.

Control Air Circuit Component Locations

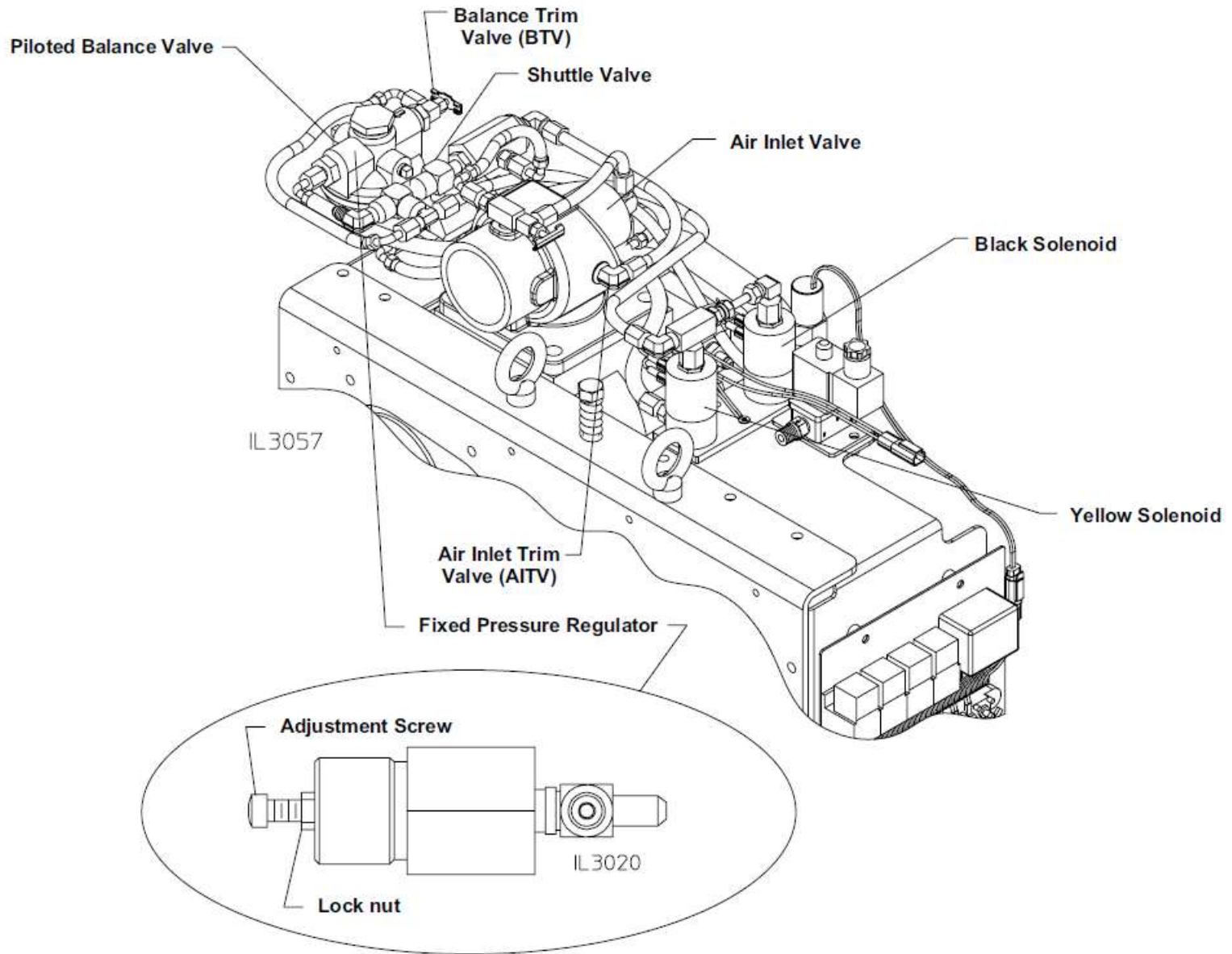

Troubleshooting Guide

Compressor System

Observed Symptom	Probable Cause	Suggested Fix
Lack of Air Pressure from Compressor <i>Compressor Not Engaging</i>	Lack of air supply to clutch (for air-clutch systems)	Repair air leak or re-establish air supply
	No pump engagement	<ul style="list-style-type: none"> • Confirm "THROTTLE READY" light is on. If not, check wiring for damage or disconnected wire. • Confirm pump is engaged.
Lack of Air Pressure from Compressor <i>Compressor Engaging / No air supply to discharges or insufficient air supply</i>	Electric Auto-Sync switches not in correct position.	<p>Confirm 40 PSI in UNLOAD position (200 CFM systems) and 50+ PSI in the RUN position. Smaller compressors have lower UNLOAD pressures.</p> <p>Verify when in FIXED/RUN whether pressure reflects 145-150 PSI.</p>
	Air check valve defective	Replace or correct installation
	Air trim valves out of adjustment	Refer to "Control Air Circuit Calibration" instructions on Pages 33 and 34.
	Restricted minimum pressure valve	Clean rust or debris from valve.
	Red line to air inlet trim valve plugged	Clean rust or debris from valve.
Lack of Air Pressure from Compressor <i>Compressor Engaging / No air supply to discharges or insufficient air supply</i>	Air plumbed before discharge valve seal	Relocated to discharge side of discharge valve.
	Incorrect air line size	Size according to discharge and replace line with correct size.
System Functioning Correctly <i>Pressure gauge reading incorrect.</i>	Gauge malfunctioning or air line detached	Check for air leaks or replace the gauge.
FIXED has pressure but AUTO has no pressure	No water supply to balance valve	<ul style="list-style-type: none"> • Check line for proper installation (no kinks or obstructions). • Refer to "Control Air Circuit Calibration" instructions on Pages 33 and 34.
Air Discharge Pressure Too High	Red hose circuit (compressed air control) has leak or is disconnected.	Repair leak or attach hose.

Observed Symptom	Probable Cause	Suggested Fix
System Overheating	Inadequate water flow through the oil cooler.	<ul style="list-style-type: none"> • Ensure adequate water flow through pump. • Check Y strainer for obstruction, clean and re-install. • Drain and flush cooler water tubes.
	Adequate water flow through oil cooler.	On-board tank used for cooling for prolonged period - water too hot to effectively cool the compressor. Locate source of lower temperature water.
		Low compressor oil level: Check oil level and adjust level to half of the sight glass on level surface.
		<ul style="list-style-type: none"> • Check the hydraulic lines for kinks. • Change oil filters.
Temperature sending unit and or gauge circuit malfunction. Check wire connections at the sending unit.		
High Oil Consumption	<ul style="list-style-type: none"> • Overfull compressor oil • Excess of 200 CFM air flow • Air/Oil Separator Filter torn or damaged (could be caused by air flow of higher than 200 CFM) 	<ul style="list-style-type: none"> • Adjust level to half of the sight glass on level surface • Back down RPM's and flow CAFS to relieve pressure, then recheck • Replace Air/Oil Separator Filter
"Excessive" compressor bleed down time on shutoff	Systems vary in bleed down time	If Electric Auto-Sync is operating correctly and the compressor output is with specifications, no action is required.
Engine Stalls Upon Compressor Engagement	<ul style="list-style-type: none"> • Engaging compressor while under load • Running system without flowing air causes oil to accumulate in compressor, acting like a hydraulic pump • Underrated engine horsepower • Electric Auto-Sync in FIXED setting • Compressor locked up • Manual Auto-Sync in FIXED / RUN setting 	<ul style="list-style-type: none"> • Allow compressor to bleed down before re-engagement. • Bleed down air, restart compressor and move air • Raise engine RPM • Engage in UNLOAD then switch to FIXED • Check oil level, adjust level to half of the sight glass with vehicle parked on a level surface. • Repair/replace compressor

Observed Symptom	Probable Cause	Suggested Fix
Compressor Locked Up	<ul style="list-style-type: none"> • High oil level (compressor is flooded) • Sump fire • Low oil or no oil 	<ul style="list-style-type: none"> • Check oil level, adjust level to half of the sight glass with the vehicle parked on a level surface. • Check sump and repair if necessary.
Poor Foam (wet or dry) or No Foam (air pressure to discharges is correct), or Discharge hose shaking (slug flow)	<ul style="list-style-type: none"> • Using wetting agent and not foam concentrate. • Foam proportioning control OFF or turned too low. • Foam tank empty 	<ul style="list-style-type: none"> • Use foam concentrate • Increase amount of concentrate delivered to the manufacturer's recommended amount. • Make sure proportioner is turned ON, foam supply valve is OPEN, foam tank has concentrate, Y strainer is clean and the supply line is connected to the injector. • Confirm air line size
Foam in the Water System (when proportioner turned OFF)	<ul style="list-style-type: none"> • Foam concentrate was poured into the on-board water tank. • Foam manifold drain lines not isolated from water drain lines. • Cooler line plumbed from foam manifold. • Foam manifold check valve defective. 	<ul style="list-style-type: none"> • Flush tank and pump with clean water and refill. • Isolate to separate drain valve. • Relocated line to discharge side of the pump. • Rebuild/replace check valve
Water in Compressor Oil/Air	<ul style="list-style-type: none"> • Leaking inside oil cooler (freeze damage) • Defective air check valves • Missing air check valves for discharges 	<ul style="list-style-type: none"> • Isolate oil cooler and check for leaks, replace if needed and check drain. • Replace or check • Install check valves
Clutch Smoking	<ul style="list-style-type: none"> • Engaging in RUN position • Slight air leak from solenoid to clutch • High RPM engagement • Not allowing compressor to bleed down before engaging clutch again. • Contaminated clutch disc. 	<ul style="list-style-type: none"> • Engage in UNLOAD only • Repair air leak • Engage in lower RPM • Clean or replace clutch disc
Safety Pop-off Valve Opening at Low Pressure	<ul style="list-style-type: none"> • Electric Auto-Sync system out of balance • Sump fire damaged pop-off valve 	<ul style="list-style-type: none"> • Refer to "Control Air Circuit Calibration" instruction on Pages 33 and 34. • Check system for other damage and replace pop-off valve.
Safety Pop-off Valve Repeatedly Opening	Trim valve or inlet completely open	Refer to "Control Air Circuit Calibration" instruction on Pages 33 and 34.