

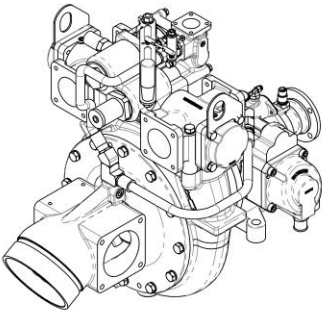

Fire Pump Models HL200, HL300 and HL400 Installation Instructions

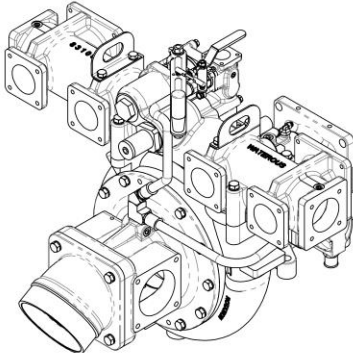

HL200D/300D



HL400D

IL4947-1

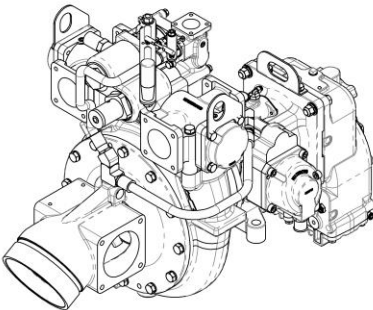

HL200K/300K

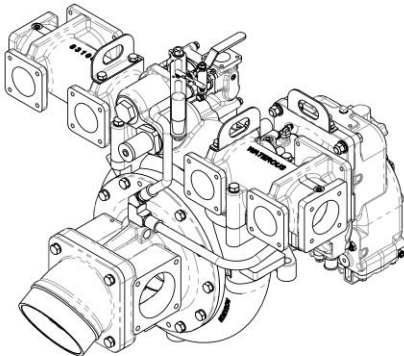

HL400K



Read through safety information and installation instructions carefully before installing your Waterous Fire Pump.

Note that Instructions are subject to change without notice.

F-1031, Section 3032
Revised: 12/30/20

Table of Contents:

Safety Information	3	Lubrication:	
Pump Operation:		Fill and Drain Locations:	
Operating Modes.....	4	Models HL200D, HL300D, HL400D.....	13
Operational Limits.....	4	Models HL200K, HL300K, HL400K.....	13
Available Pump Drives	5	Lubricants and Quantities.....	14
Available Pump Intake and Discharge Connections	5	Operating the Pump.....	14
Installation:			
Pump Components.....	6		
Pump Lifting Points.....	6		
Pump Mounting.....	7		
Pump Intake.....	8		
Low Pressure Discharge.....	8		
High Pressure Discharge.....	8		
High Pressure Inlet Strainer.....	8		
High Pressure Relief Valve.....	8		
Piston Primers:			
Clearance for Service.....	9		
Discharge.....	9		
Tachometer Connection.....	10		
Water Drains:			
Pump.....	10		
K Transmission Oil Cooler.....	11		
Optional Components:			
Solenoid Valve for Priming Isolation Valve (PIV).....	12		
RTP Foam System.....	12		
Control Panel.....	12		

Safety Information



Read through and communicate safety information to the end user of this Waterous Fire Pump.

WARNING

Death or serious personal injury might occur if proper operating procedures are not followed. The pump operator, as well as individuals connecting supply or discharge hoses to the apparatus must be familiar with these pump operating instructions as well as other operating instructions and manuals for the apparatus, water hydraulics and component limitation.

WARNING

Pressure Hazard. May result in personal injury.

Prior to connection or removal of hoses, caps or other closures with pump intake or pump discharge connections, relieve pressure by opening drains or bleeder valves. Bleeder valves should also be used while filling a hose connected to an intake with water.

WARNING

Scalding Water Hazard. May result in serious burns.

When operating the pump, be sure to open at least one discharge valve slightly to prevent the pump from overheating. If the pump runs for a few minutes completely closed, it may heat the water enough to scald someone when the valve is opened. Overheating can damage the packing, seals and other pump parts. If the apparatus builder has installed a by-pass system or other provision designed to prevent overheating, opening a discharge valve may be unnecessary.

WARNING

Rotating Parts Hazard or Unexpected Truck Movement. May result in serious personal injury or death.

Stop the engine, set parking brake and chock the wheels before going under the truck to adjust packing or to check packing gland temperature.

OEM Installation Warnings

WARNING

Unexpected Truck Movement. May result in serious personal injury or death.

Failure to properly install the pump shift control and pump shift indicator system in the apparatus or failure to incorporate in the Pump Operator's Panel Engine Speed Interlock System may result in unexpected truck movement which may result in serious personal injury or death.

WARNING

Inability to Pump Water. May result in serious personal injury or death.

Failure to properly install the pump shift control and pump shift indicator system in the apparatus or failure to incorporate in the Pump Operator's Panel Engine Speed Interlock System may result in the inability to pump water which may result in serious personal injury or death.

WARNING

Exceeding Power Train Torque Ratings. May result in inability to pump water causing serious personal injury or death.

This fire pump may have the capability under certain pumping conditions to exceed the torque rating of the power train.

A means to control the engine output to a torque level no greater than the power train's continuous-duty torque rating must be considered when specifying power train components and engine control system parameters.

Operating Modes

HL series pumps are designed to operate in two modes:

Low Pressure Mode:

Pump Discharges only low pressure water.

High Pressure Mode:

Pump simultaneously discharges low and high pressure water.

Three performance levels are available:

Model	Low Pressure	High Pressure
HL200	2000 L/min at 10 bar	400 L/min at 40 bar
HL300	3000 L/min at 10 bar	
HL400	4000 L/min at 10 bar	

Operational Limits

Maximum Low Pressure:

Control the speed of the pump so that the maximum low pressure is limited to 17 bar.

Maximum High Pressure:

The maximum high pressure is internally limited by the high pressure relief valve not to exceed 55 bar.

Maximum Angle of Inclination:

The maximum angle of inclination for pump operation is 15°.

Maximum Pump Speed:

The pump has a maximum operating speed of 3450 rpm. Do not exceed this speed.

Maximum Priming Speed:

When Priming, the pump speed should be limited to 2600

Available Pump Drives

Drive	Transmission				Complete Pump and Transmission Model		
	Type	Series	Model	Input Shaft Rotation	HL200	HL300	HL400
PTO	None, Direct Drive from PTO	D	D	Clockwise or Counter Clockwise	HL200D	HL300D	HL400D
	Two Gear Speed Increaser	K	K	Clockwise or Counter Clockwise	HL200K	HL300K	HL400K

Available Pump Intake and Discharge Connections

Pump Model	Intake		Discharge
HL200	Single Inlet	4 in. BSP 5 in. Grooved 110 mm Storz 4-Bolt Flange	Manifold with Seven Outlets
HL300	Single Inlet	4 in. BSP 5 in. Grooved 110 mm Storz 4-Bolt Flange	
	Dual Inlet	4 in. BSP	
HL400	Single Inlet	6 in. BSP 4-Bolt Flange	Manifold with Nine Outlets
	Dual Inlet	4 in. BSP	

Installation

Pump Components

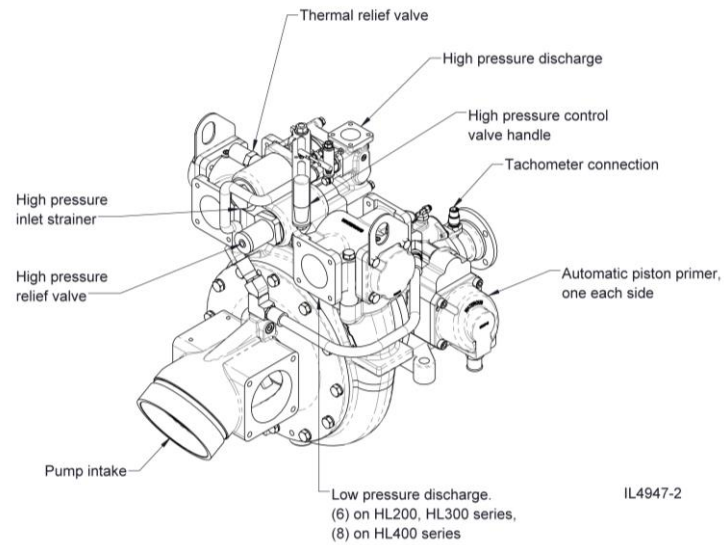

Pump Lifting Points

Models HL200D, HL300D, HL400D

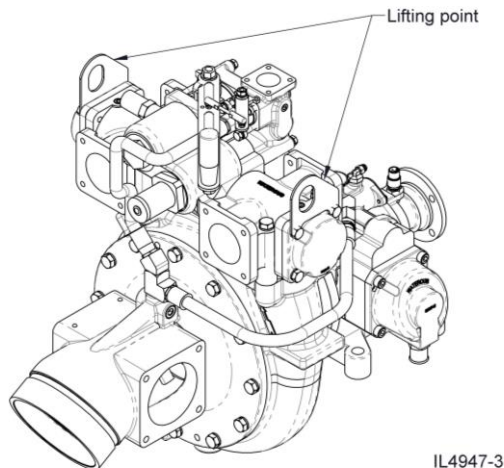

Models HL200K, HL30K, HL400K

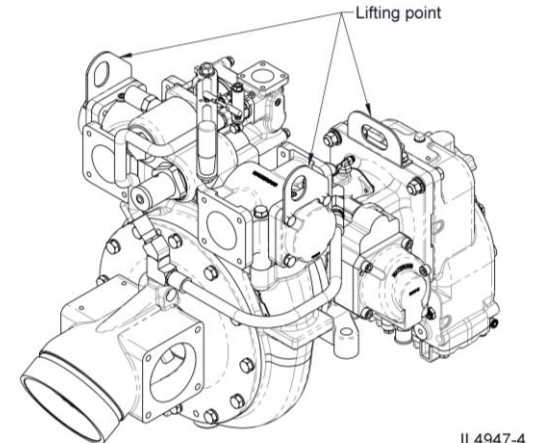

Installation – Pump Mounting

Select a mounting location which will make the pump and its accessories readily accessible for maintenance and which will make the pump driveshaft parallel with the output shaft of the chassis transmission or transfer case. Also, select the location so that when the apparatus is loaded, the universal joints on the propeller shaft will have a proper working angle. Be sure the propeller shaft used are of the slip-joint design. Frame deflection, temperature changes and similar factors may cause a propeller shaft without slip-joints to produce severe axial loads on the bearings and damage the pump.

Four mounting holes are located on the pump pedestal that are to be used to secure the pump to a mounting plate (plate not supplied by Waterous). The mounting plate should be designed with the four mounting holes (see diagram below for dimensions). The plate should also provide clearance for the volute flange as identified in the diagram below.

Attach the pump to the mounting plate and secure to the vehicle with M16 bolts. Tighten fasteners to 176-190 N•m (130-140 lb-ft).

Be sure to keep at least a minimum of 1° U-joint operating angle. This is the preferred method of propeller shaft installation. For additional information on this method, or for alternative methods, see driveshaft installation guidelines such as Spicer® / Driveshaft Installation Techniques.

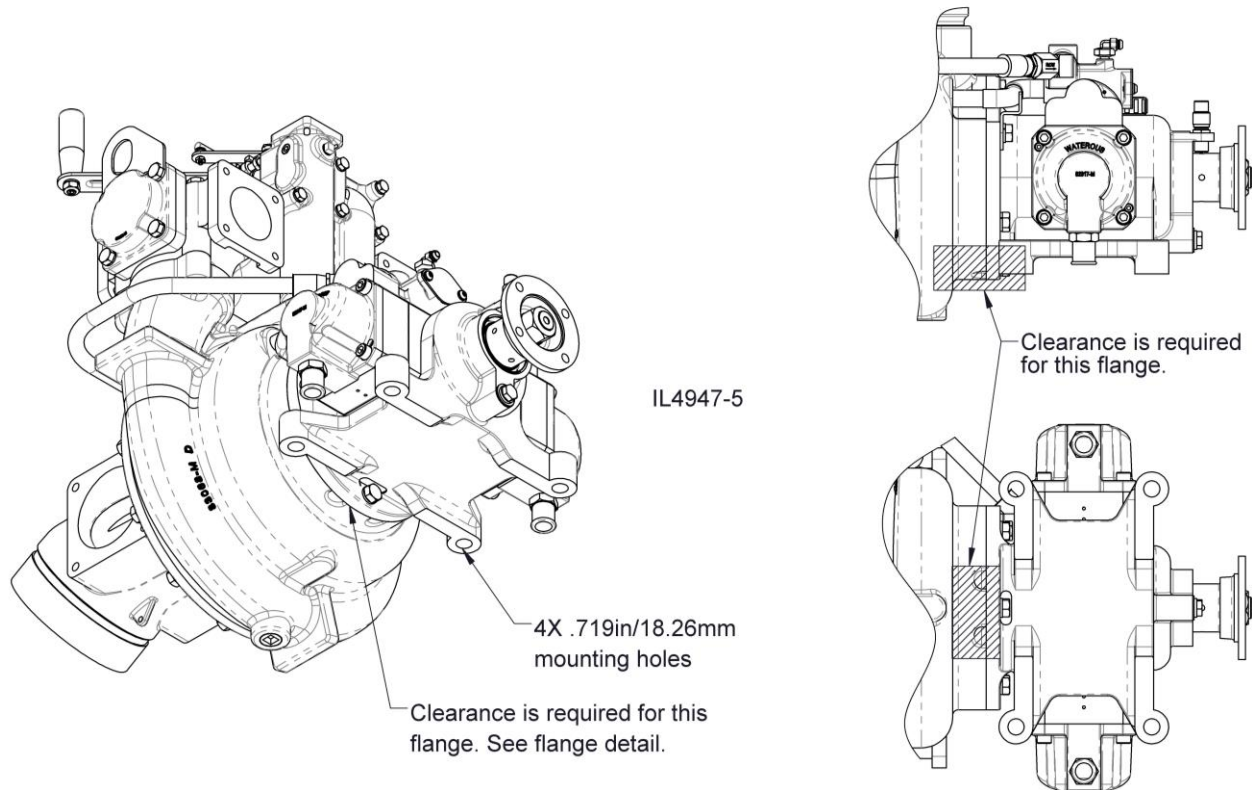

Installation

Pump Intake:

If piping is to be attached to the pump intake, provisions must be made to allow the removal of the pump intake adapter while the pump remains in the vehicle. This is necessary to provide access to the pump for repairs and maintenance. Note that a suitable strainer should be installed in each intake opening on the pump.

Low Pressure Discharge:

Any piping connected to the low pressure discharge opening on the pump discharge manifold must be properly supported and secured.

High Pressure Discharge:

Any Piping connected to the high pressure discharge opening on the pump discharge manifold must be suitable for high pressure and properly supported and secured.

High Pressure Inlet Strainer:

Pump installation should provide access as this is a maintenance item.

High Pressure Relief Valve:

Pump Installation should provide access as this is a maintenance item

Thermal Relief Valve:

The valve is designed to discharge water if the temperature of the pump Water reaches 49° C. The discharge water must be diverted away from the pump operator.

Install a suitable 1/2 in. fitting and tube or hose assembly and route to one of the following locations:

To the holding tank, vehicle tank or the atmosphere (ground).

The piping must not be restricted in any way,

Installation – Piston Primers

Clearance for Service:

The pump has two automatic piston primers located on each side of the pump pedestal. Pump installation must provide 50 mm (2 in.) of space behind the primers to allow them to be removed for servicing.

Discharge

During operation, the primers can discharge water. This water exits through the primer discharge outlets. It is important that this water is not restricted in any way. Typically the water is discharged to the ground.

A suitable hose may be used to assist in directing the water to the ground, however, it is not recommended that any angled fittings be used as they will restrict the flow.

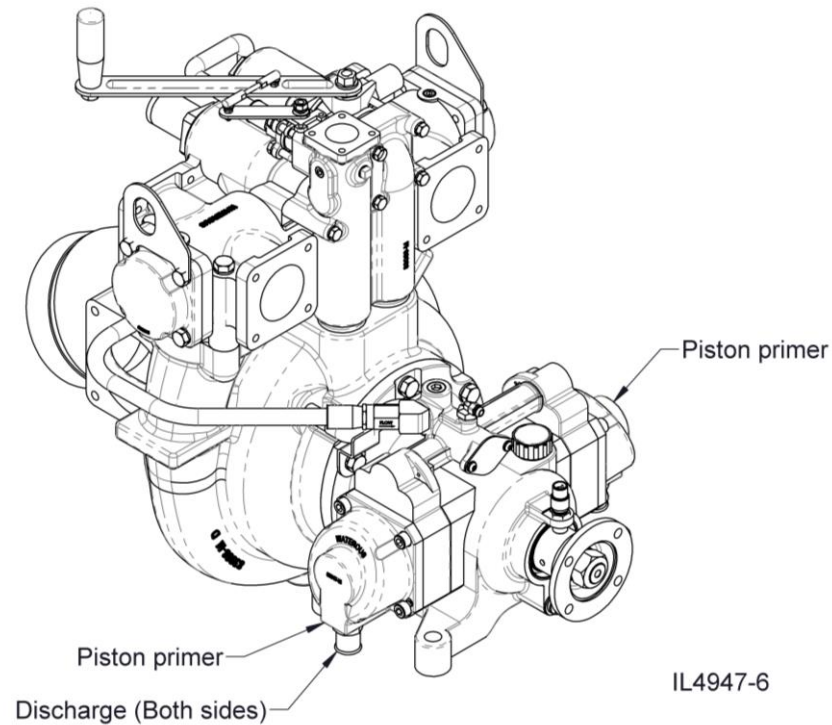

Installation

Tachometer:

If optional control panel was not furnished:

The pump includes a magnetic pick-up installed in the pump pedestal which allows a tachometer to be connected. A 10 meter cable is included with the pump which mates with the magnetic pick-up (Amphenol connector part no. MS3106A-10SL-4S).

If optional control panel was furnished:

The tachometer is included in the control panel and the wiring to the magnetic pick-up was completed at the factory.

Pump Water Drains:

The pump is provided with a 3/4 NPT tap to allow water to be drained. The drain should be fitted with a valve and piping. The piping should be routed to a suitable draining location.

Note: All piping, fittings and valves must be suitable for pressures that are present in the low pressure stages.

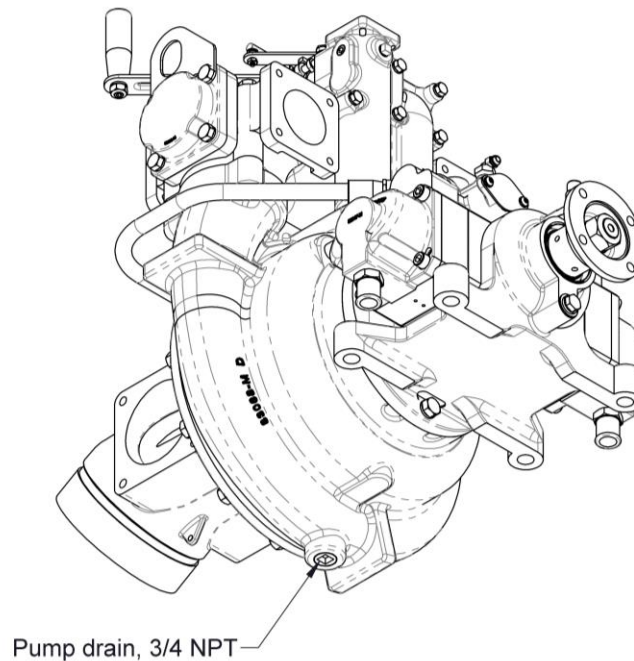

IL4947-7

Installation – K Transmission Water Drain

The bottom pan of the transmission acts as an oil cooler and must be drained. The transmission has a 1/4 in. NPT tap for installation of a drain line.

Note: All piping, fittings and valves must be suitable for pressures that are present in the low and high pressure stages.

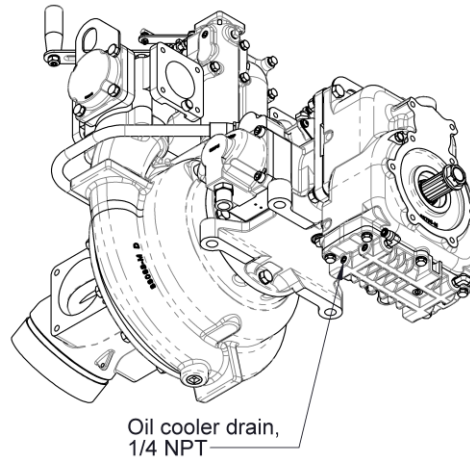

Vertical Transmission Mounting

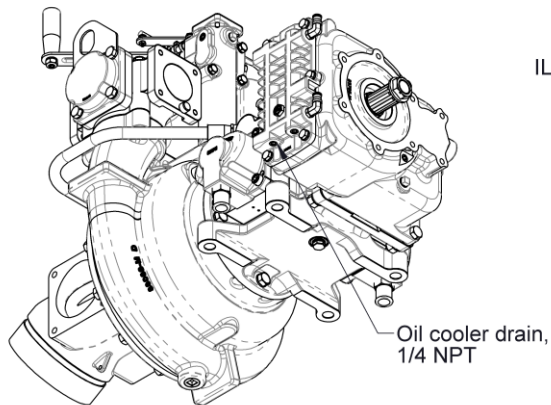

Left Transmission Mounting

IL4947-8

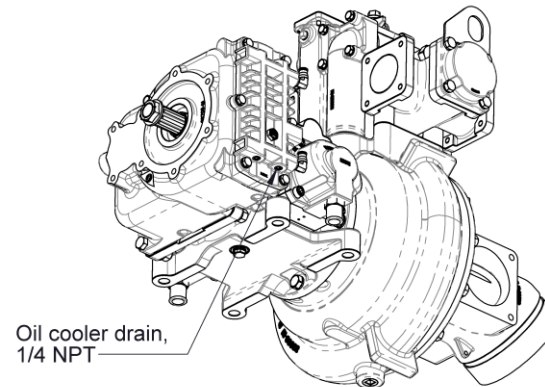

Right Transmission Mounting

Installation – Optional Components

Solenoid Valve for Priming Isolation Valve (PIV):

Refer to instructions furnished with components

12 Volt Systems, Parts Kit L 1229-12, Instruction I-1676

24 Volt Systems, Parts Kit L 1229-24, Instruction I-1677

RTP Foam System:

Refer to instructions furnished with components

System mounted on pump at the factory: Parts Kit L 1172, Instruction I-1901

System installed by OEM:

L/min flow: Parts kit L 1171-1, Instruction I-1936

L/sec flow: Parts kit L 1171-2, Instruction I-2022

GPM flow: Parts kit L 1171-3, Instruction I-2055

Control Panel

Connections must be completed for the following:

Tachometer/Hourmeter, Pump Overheat Module, Pump Engaged Module, Tank Level Monitors (electrical and lines to tanks)

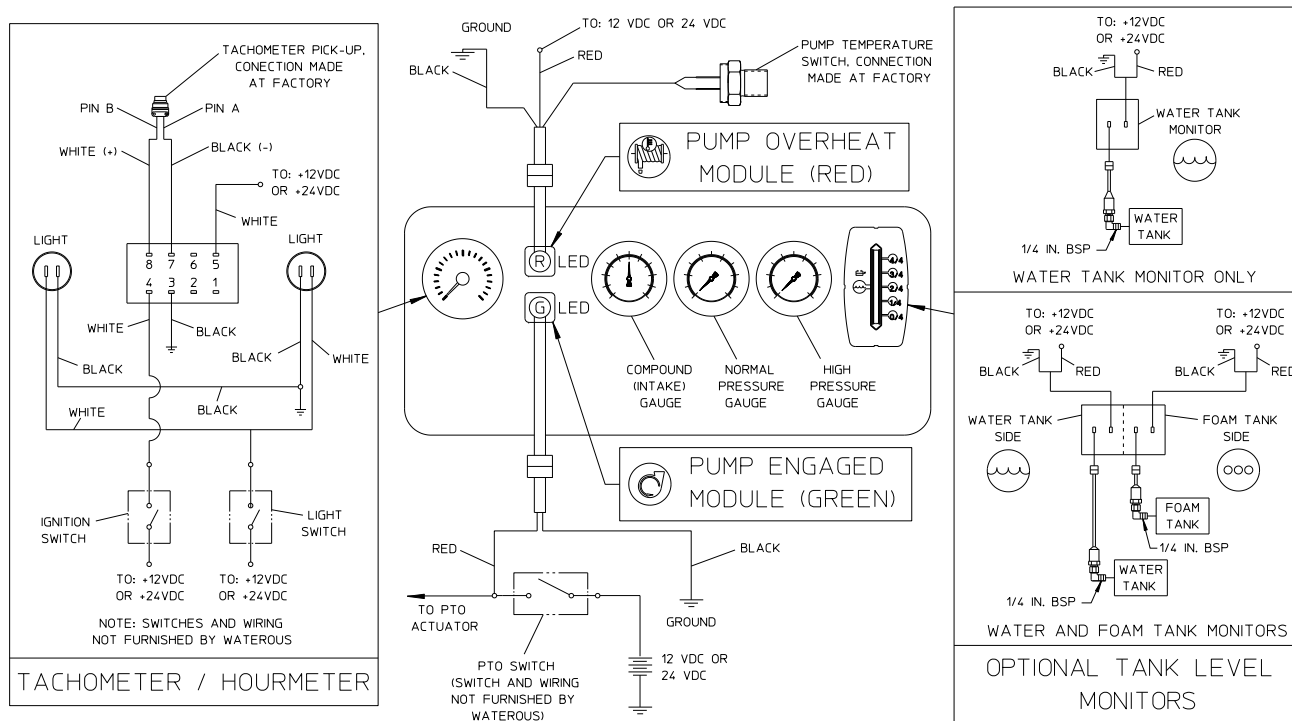

IL3563

Primer Oil Fill and Drain Locations

Note: Provisions for access to the lubrication fills and drains must be provided.

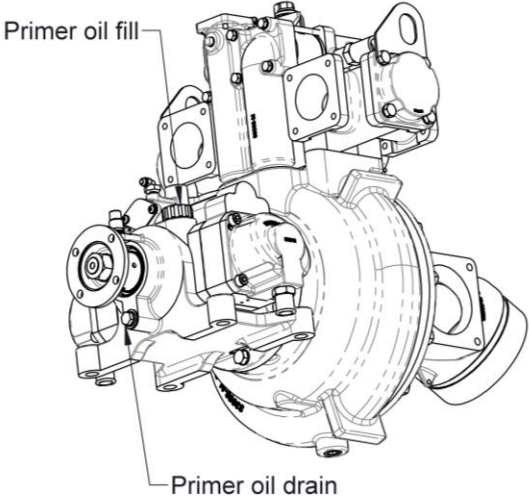

HL200D, HL300D

IL4947-9

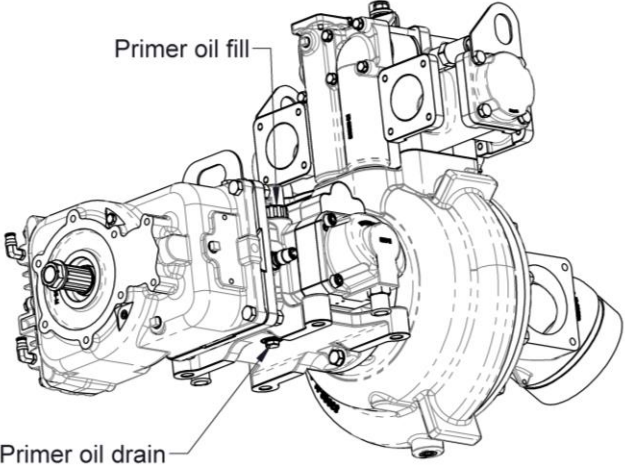

HL200K, HL300K, HL400D, HL400K

Note: For transmission oil fill and drain locations, refer to the pump dimensional drawing.

Final Checks

Lubrication

Transmissions are shipped without lubricant and must be filled before the pump is operated.

NOTICE
Failure to properly lubricate the pump transmission may result in serious damage to the equipment.

The types of recommended lubricants are listed below:

Pump Model	Capacity <i>(See Note 1)</i>		Lubricant <i>(See Note 2)</i>
	Primer Housing	Transmission	
HL200D HL300D HL400D	.95 Liters (1 Quart)	-	SAE 10W-30 Motor Oil
HL200K HL300K HL400K	.95 Liters (1 Quart)	.95 Liters (1 Quart)	SAE 80W-90 Gear Oil

Notes:

- 1) Capacities shown are approximate, always fill to the marking on the dipstick for HL200D, HL300D and HL400D models, or bottom of the plug labeled "Oil Level" for models HL200K, HL300K and HL400K. Quantities
- 2) Synthetic ATF and oil substitutes are preferred.

Operating the Pump

To run the pump, follow the instructions in F-1031, section 2408 *HL Series Pump Operation and Maintenance Instructions*. During the running of the pump, monitor the smoothness of operation, listen for unusual noises and check for leaks.