



Fire Pump Models CR, CRU-1 and CRU-2 Installation Instructions

Available Pump Models

Pump				Drive	Complete Pump and Transmission Model
Series	Model	Intake	Discharge		
CR	CR	8 in. Victaulic®	5 in. Victaulic®	Direct (No Transmission)	CR
				QA Transmission	CRQA
				QB Transmission	CRQB
CRU	CRU-1	8 in. ANSI Flange	5 in. Victaulic®	Direct (No Transmission)	CRU-1
	CRU-2	10 in. Victaulic®	6 in. ANSI Flange	Direct (No Transmission)	CRU-2
				C21 Transmission	CRUC21-2
				QC Transmission	CRUQC-2

Table of Contents

Safety Information..... 2

Pump Mounting Locations:

CR Pump Models:

Model CR (Direct Drive).....3

Model CRQA..... 4

Model CRQB:

QB Transmission Mounting Position:

Horizontal..... 5

Horizontal, Rotated 11°..... 6

Model CRQC:

QC Transmission Mounting:

Vertical.....7

Vertical, Rotated 45°..... 8

CRU-1 Pump Models:

Model CRU-1 (Direct Drive)..... 9

CRU-2 Pump Models:

Model CRU-2 (Direct Drive)..... 10

Model CRUQC-2:

Without Bellhousing Adapter.....11

With Bellhousing Adapter..... 12

Model CRUC21-2:

Pump Mounting on Transmission:

Front (Input Shaft Side)..... 13

Rear (Output Shaft Side)..... 14

Final Checks:

Lubrication..... 15

Testing..... 15



Read through the safety information and installation instructions carefully before installing your Waterous CR/CRU Series Fire Pump.

NOTE: Instructions subject to change without notice

Safety Information



Read through and communicate safety information to the end user of this Waterous Fire Pump.



WARNING

Death or serious personal injury might occur if proper operating procedures are not followed. The pump operator, as well as individuals connecting supply or discharge hoses to the apparatus must be familiar with these pump operating instructions as well as other operating instructions and manuals for the apparatus, water hydraulics and component limitation.



WARNING

Pressure Hazard. May result in personal injury.

Prior to connection or removal of hoses, caps or other closures with pump intake or pump discharge connections, relieve pressure by opening drains or bleeder valves. Bleeder valves should also be used while filling a hose connected to an intake with water.



WARNING

Scalding Water Hazard. May result in serious burns.

When operating the pump, be sure to open at least one discharge valve slightly to prevent the pump from overheating. If the pump runs for a few minutes completely closed, it may heat the water enough to scald someone when the valve is opened. Overheating can damage the packing, seals and other pump parts. If the apparatus builder has installed a by-pass system or other provision designed to prevent overheating, opening a discharge valve may be unnecessary.



WARNING

Rotating Parts Hazard or Unexpected Truck Movement. May result in serious personal injury or death.

Stop the engine, set parking brake and chock the wheels before going under the truck to adjust packing or to check packing gland temperature.

OEM Installation Warnings



WARNING

Unexpected Truck Movement. May result in serious personal injury or death.

Failure to properly install the pump shift control and pump shift indicator system in the apparatus or failure to incorporate in the Pump Operator's Panel Engine Speed Interlock System may result in unexpected truck movement which may result in serious personal injury or death.



WARNING

Inability to Pump Water. May result in serious personal injury or death.

Failure to properly install the pump shift control and pump shift indicator system in the apparatus or failure to incorporate in the Pump Operator's Panel Engine Speed Interlock System may result in the inability to pump water which may result in serious personal injury or death.



WARNING

Exceeding Power Train Torque Ratings. May result in inability to pump water causing serious personal injury or death.

This fire pump may have the capability under certain pumping conditions to exceed the torque rating of the power train.

A means to control the engine output to a torque level no greater than the power train's continuous-duty torque rating must be considered when specifying power train components and engine control system parameters.

Model CR (Direct Drive) Mounting Locations

Attach brackets to the bearing housing and the intake adapter. Secure the pump and bearing housing to the vehicle.

NOTE: Tighten the mounting screws to standard torque specifications

Anti-seize should be applied to the shaft threads before installing end yoke or companion flange. Do not reuse self-locking nuts, torque to 275-325 lb-ft.

Note that the pump discharge may be positioned Up, Right or Left. The intake side mounting bracket and mounting flange on the bearing housing may be positioned Vertical or Inverted.

Refer to the configuration of the pump you ordered and pump dimensional drawing for details specific to your pump.

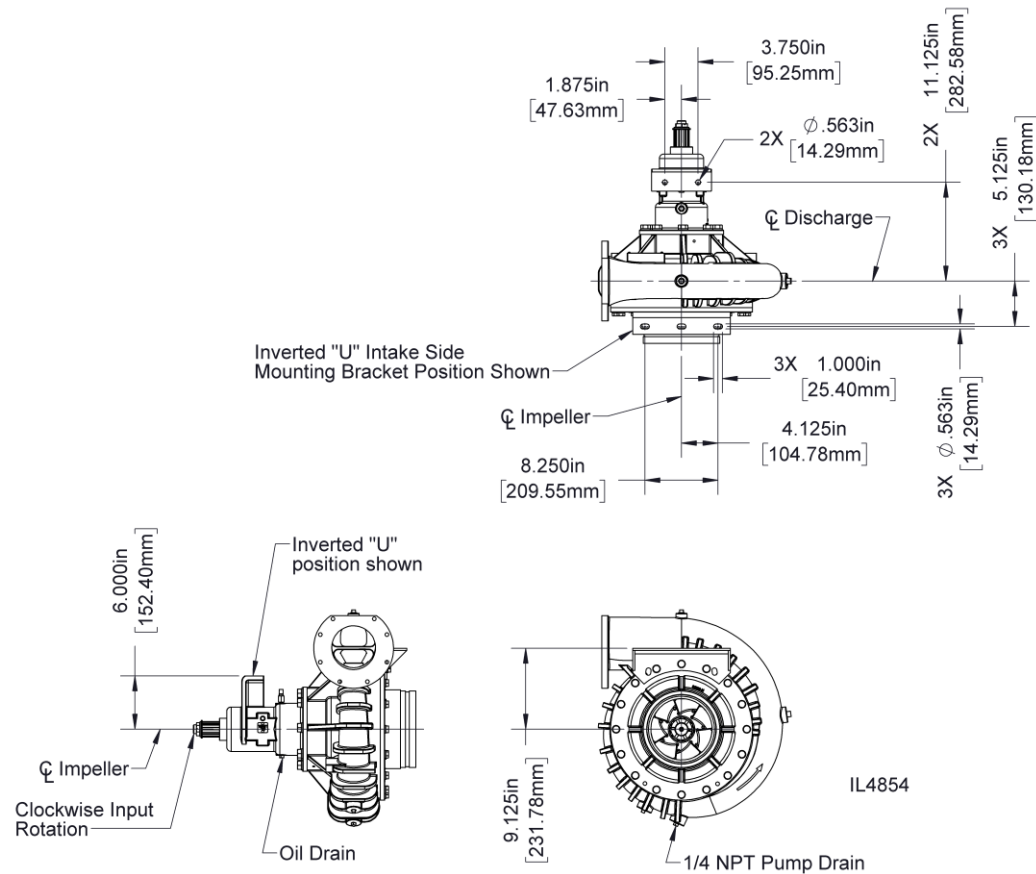

Model CRQA Mounting Locations

Attach brackets to the transmission and the intake adapter. Secure the pump and transmission to the vehicle.

NOTE: Tighten the mounting screws to standard torque specifications

Anti-seize should be applied to the shaft threads before installing end yoke or companion flange. Do not reuse self-locking nuts, torque to 275-325 lb-ft.

Note that the pump discharge may be positioned Up, Right or Left. The intake side mounting bracket and mounting flange on the bearing housing may be positioned Vertical or Inverted.

Refer to the configuration of the pump you ordered and pump dimensional drawing for details specific to your pump.

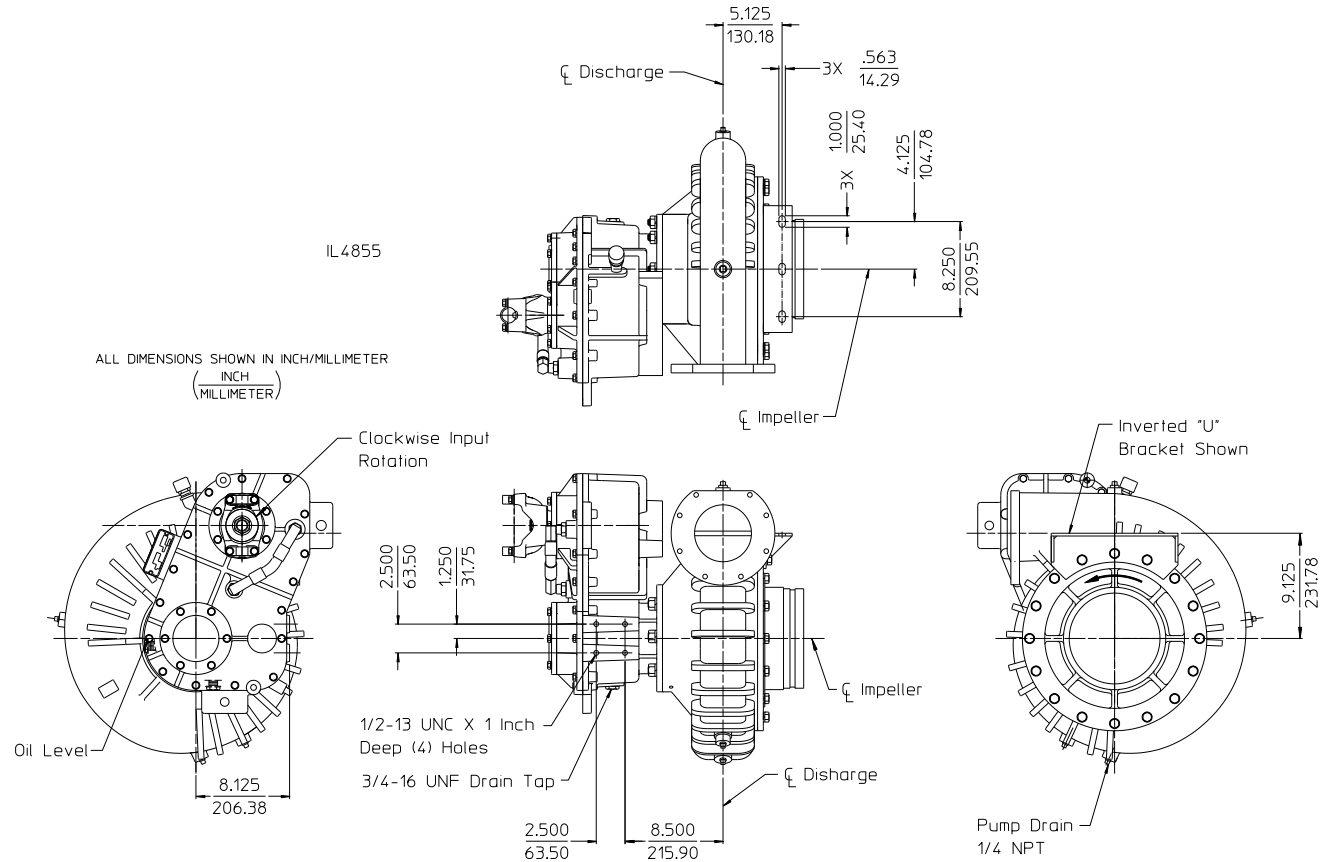

Model CRQB Mounting Locations

Horizontal Mounted Transmission

Attach brackets to the transmission and the intake adapter. Secure the pump and transmission to the vehicle.

NOTE: Tighten the mounting screws to standard torque specifications

Anti-seize should be applied to the shaft threads before installing end yoke or companion flange. Do not reuse self-locking nuts, torque to 275-325 lb-ft.

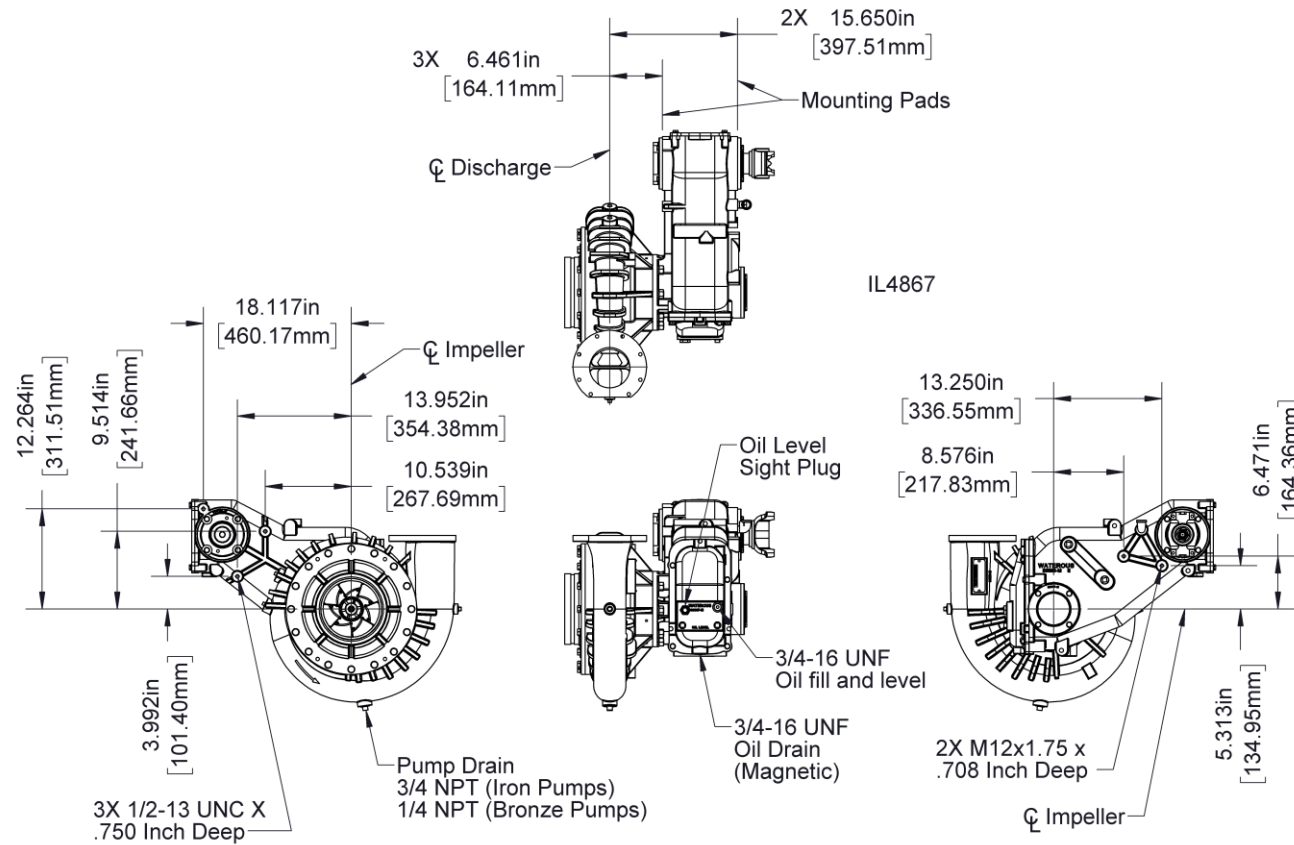

Model CRQB Mounting Locations

Horizontal Mounted Transmission, Rotated 11°

Attach brackets to the transmission and the intake adapter. Secure the pump and transmission to the vehicle.

NOTE: Tighten the mounting screws to standard torque specifications

Anti-seize should be applied to the shaft threads before installing end yoke or companion flange. Do not reuse self-locking nuts, torque to 275-325 lb-ft.

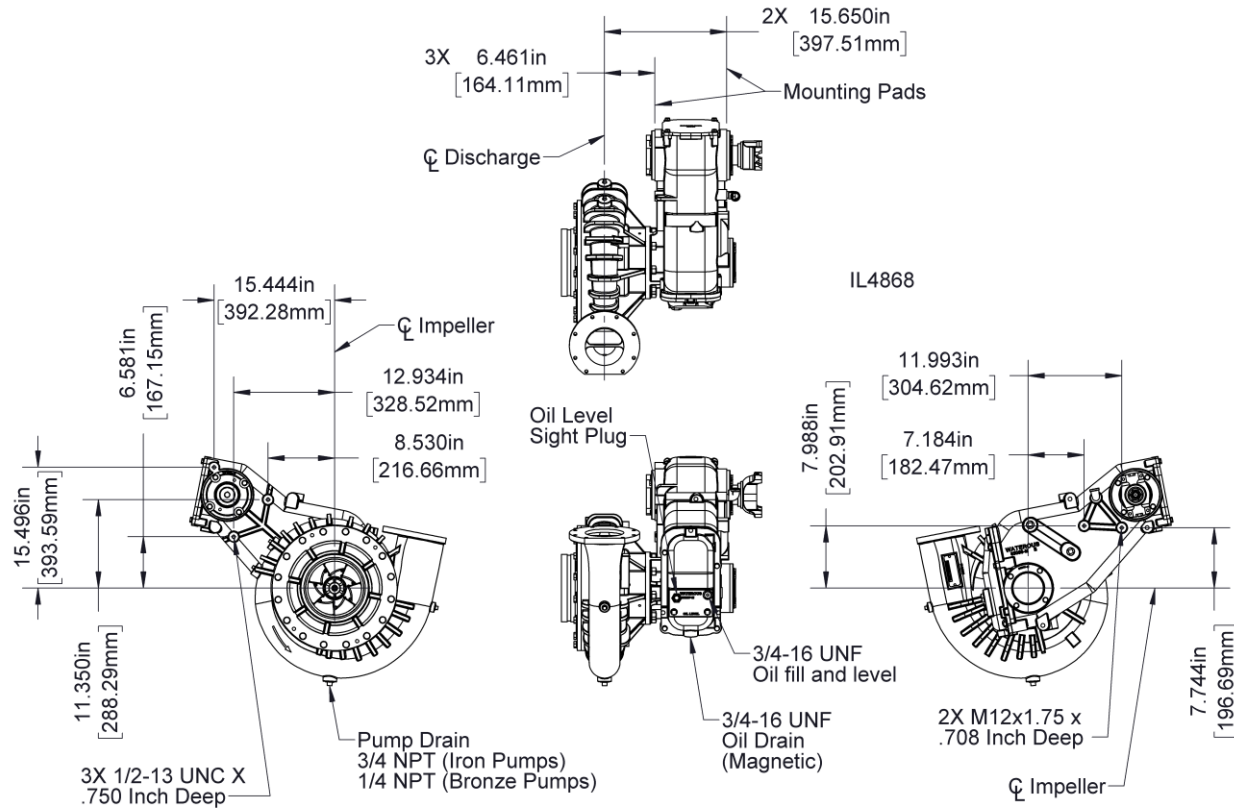

Model CRQC Mounting Locations

Vertical Mounted Transmission

Attach brackets to the transmission and the intake adapter. Secure the pump and transmission to the vehicle.

NOTE: Tighten the mounting screws to standard torque specifications

Anti-seize should be applied to the shaft threads before installing end yoke or companion flange. Do not reuse self-locking nuts, torque to 275-325 lb-ft.

Note that the intake side mounting bracket may be positioned vertical or inverted.

Refer to the configuration of the pump you ordered and pump dimensional drawing for details specific to your pump.

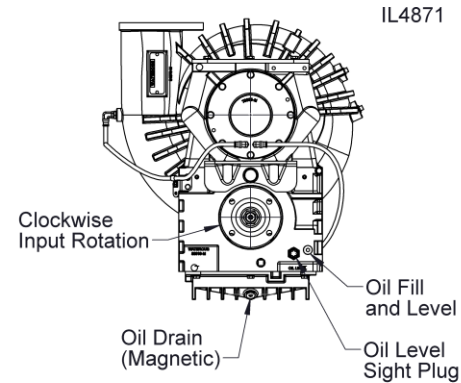
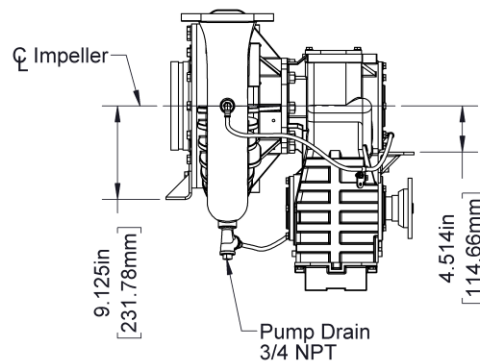
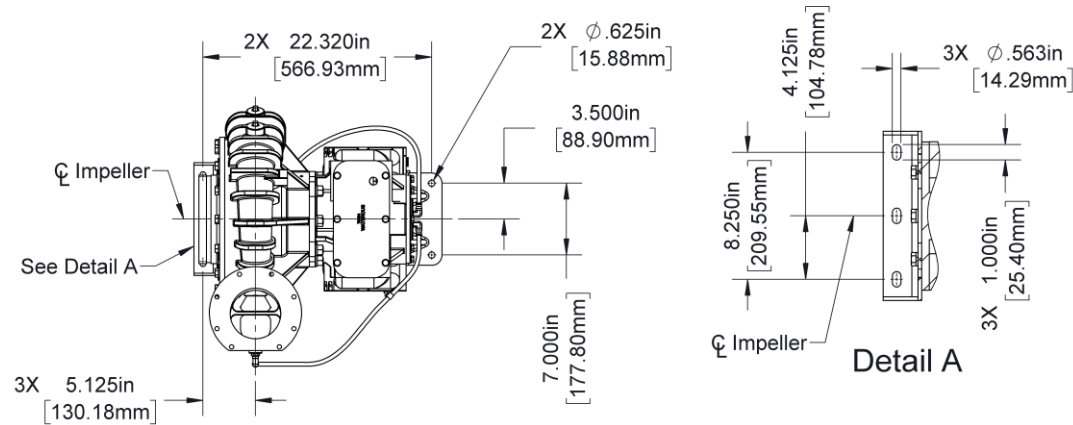

Model CRQC Mounting Locations

Vertical Mounted Transmission, Rotated 45°

Attach brackets to the transmission and the intake adapter. Secure the pump and transmission to the vehicle.

NOTE: Tighten the mounting screws to standard torque specifications

Anti-seize should be applied to the shaft threads before installing end yoke or companion flange. Do not reuse self-locking nuts, torque to 275-325 lb-ft.

Note that the intake side mounting bracket may be positioned vertical or inverted.

Refer to the configuration of the pump you ordered and pump dimensional drawing for details specific to your pump.

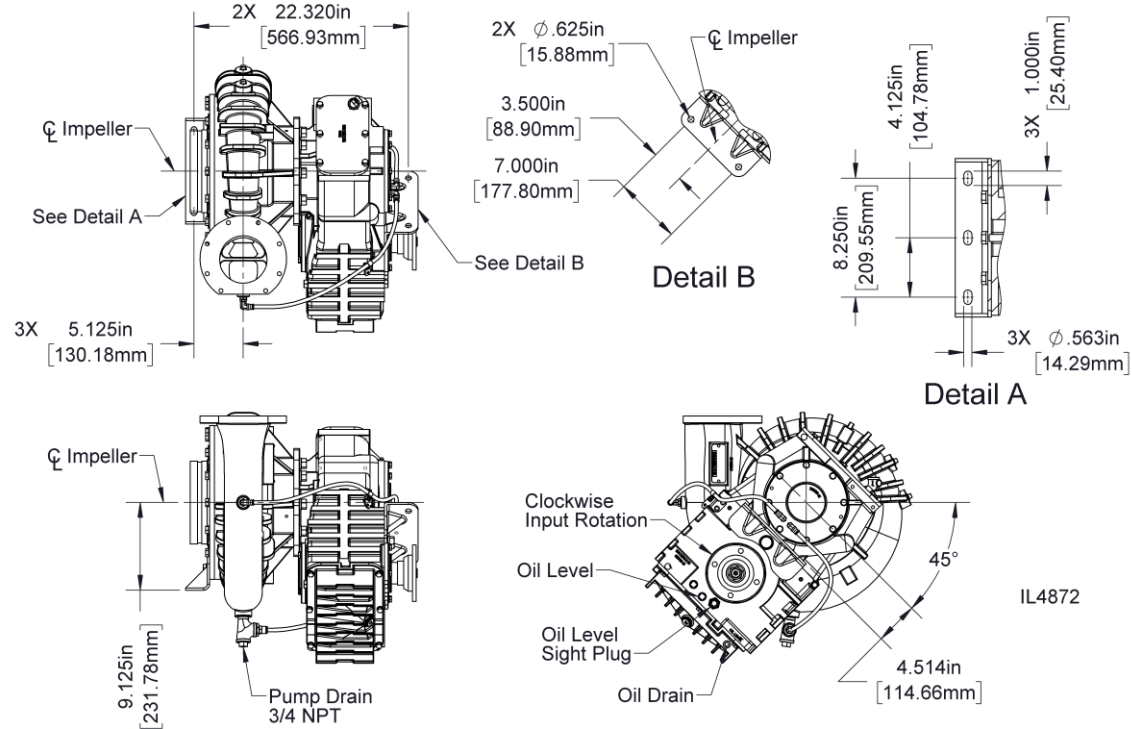

Model CRU-1 (Direct Drive) Mounting Locations

Attach brackets to the transmission and the intake adapter. Secure the pump and transmission to the vehicle.

NOTE: Tighten the mounting screws to standard torque specifications

Anti-seize should be applied to the shaft threads before installing end yoke or companion flange. Do not reuse self-locking nuts, torque to 275-325 lb-ft.

Note that the pump discharge may be positioned Up, Right or Left. The intake side mounting bracket may be positioned Vertical or Inverted.

Refer to the configuration of the pump you ordered and pump dimensional drawing for details specific to your pump.

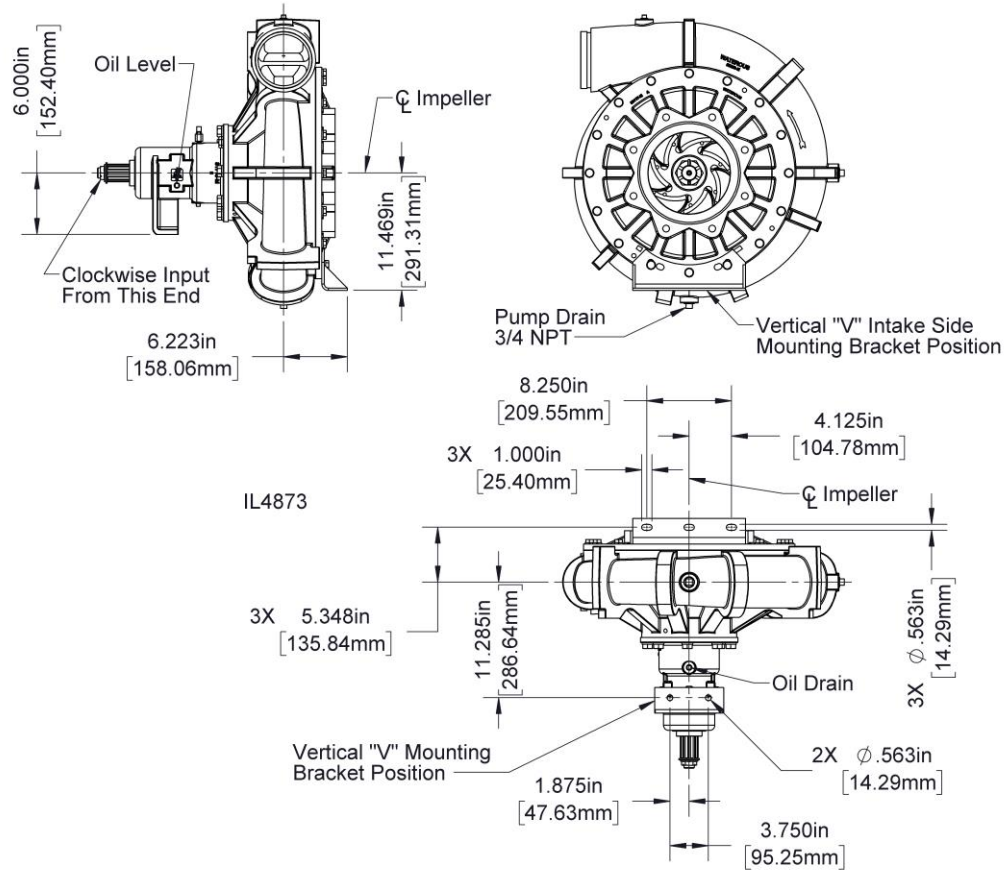

Model CRU-2 (Direct Drive) Mounting Locations

Attach brackets to the transmission and the intake adapter. Secure the pump and transmission to the vehicle.

NOTE: Tighten the mounting screws to standard torque specifications

Anti-seize should be applied to the shaft threads before installing end yoke or companion flange. Do not reuse self-locking nuts, torque to 275-325 lb-ft.

Note that the pump discharge may be positioned Up, Right or Left. The intake side mounting bracket may be positioned Vertical or Inverted.

Refer to the configuration of the pump you ordered and pump dimensional drawing for details specific to your pump.

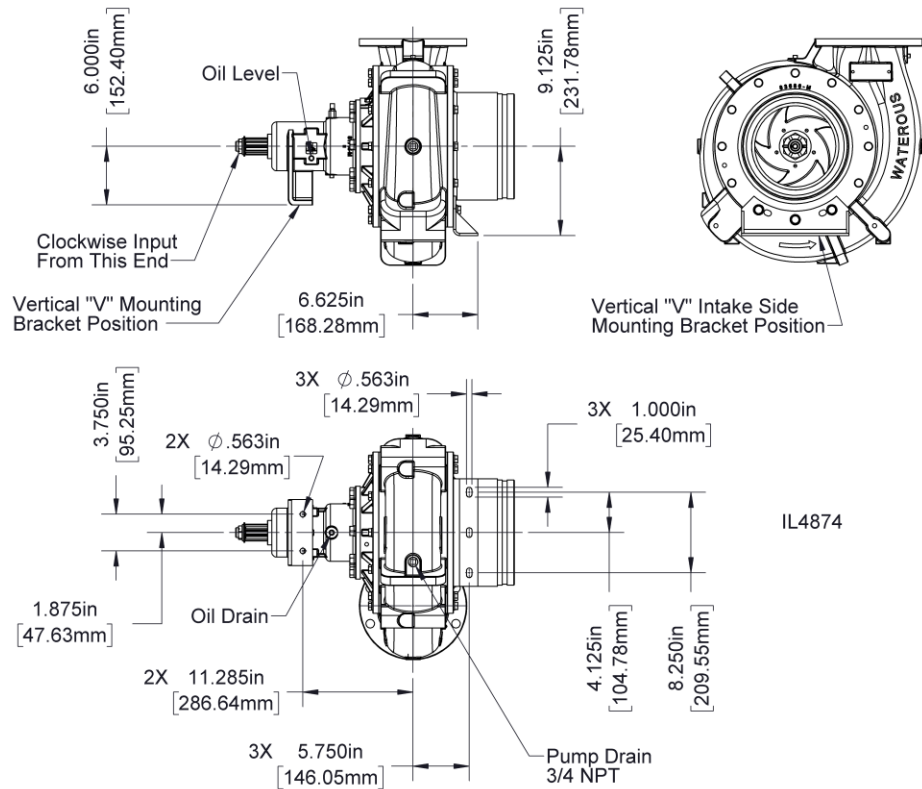

Model CRUQC-2 Mounting Locations

Without Bellhousing Adapter

Attach brackets to the transmission and the intake adapter. Secure the pump and transmission to the vehicle.

NOTE: Tighten the mounting screws to standard torque specifications

Anti-seize should be applied to the shaft threads before installing end yoke or companion flange. Do not reuse self-locking nuts, torque to 275-325 lb-ft.

Note that the pump discharge may be positioned Up, Right or Left. The intake side mounting bracket may be positioned Vertical or Inverted.

Refer to the configuration of the pump you ordered and pump dimensional drawing for details specific to your pump.

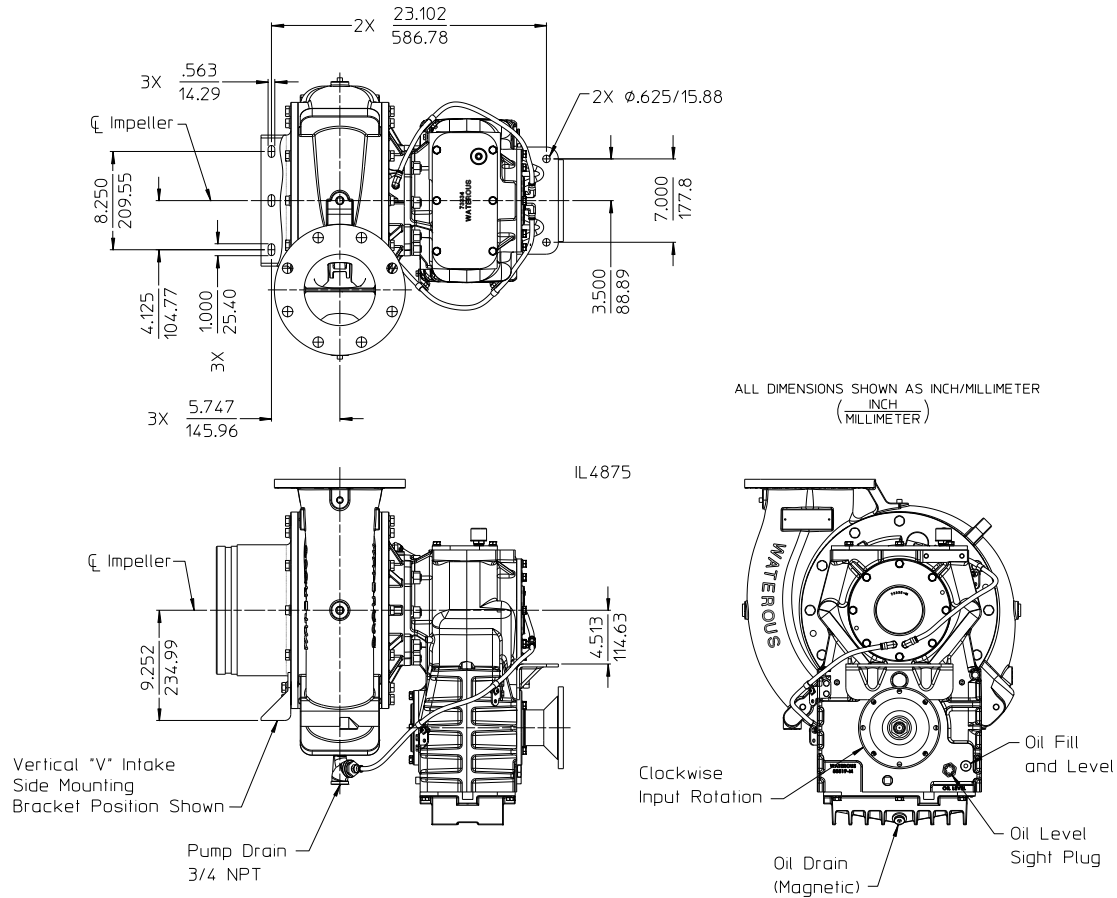

Model CRUQC-2 Mounting Locations

With Bellhousing Adapter

Bolt bellhousing adapter to the engine. Attach brackets to the intake adapter and secure to the vehicle frame.

NOTE: Tighten the mounting screws to standard torque specifications

Anti-seize should be applied to the shaft threads before installing end yoke or companion flange. Do not reuse self-locking nuts, torque to 275-325 lb-ft.

Note that the pump discharge may be positioned Up, Right or Left. The intake side mounting bracket may be positioned Vertical or Inverted. The transmission may be mounted vertical or inverted.

Refer to the configuration of the pump you ordered and pump dimensional drawing for details specific to your pump.

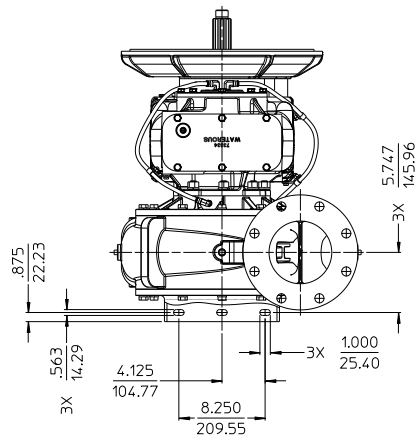

ALL DIMENSIONS SHOWN AS INCH/MILLIMETER
(INCH / MILLIMETER)

IL4876

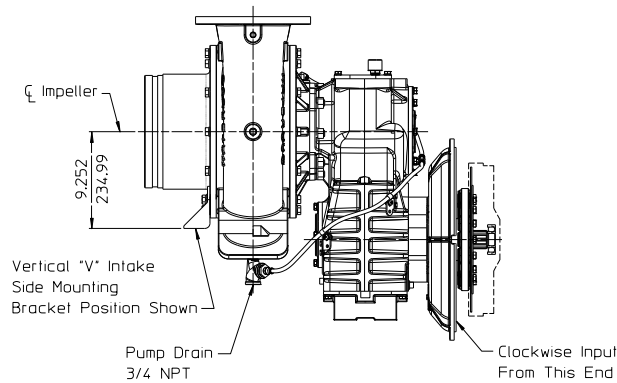
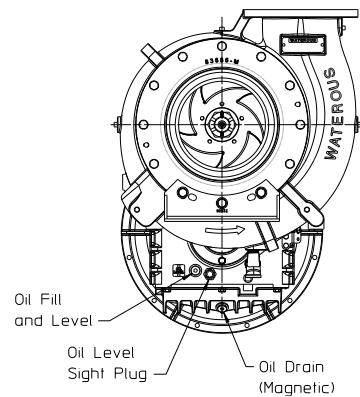

Model CRUC21-2 Mounting Locations

Pump Mounted on Front (Input Shaft Side) Transmission

Attach brackets to the transmission and the intake adapter. Secure the pump and transmission to the vehicle.

NOTE: Tighten the mounting screws to standard torque specifications

Anti-seize should be applied to the shaft threads before installing end yoke or companion flange. Do not reuse self-locking nuts, torque to 275-325 lb-ft.

Note that the pump discharge may be positioned Up, Right or Left. The intake side mounting bracket may be positioned Vertical or Inverted.

Refer to the configuration of the pump you ordered and pump dimensional drawing for details specific to your pump.

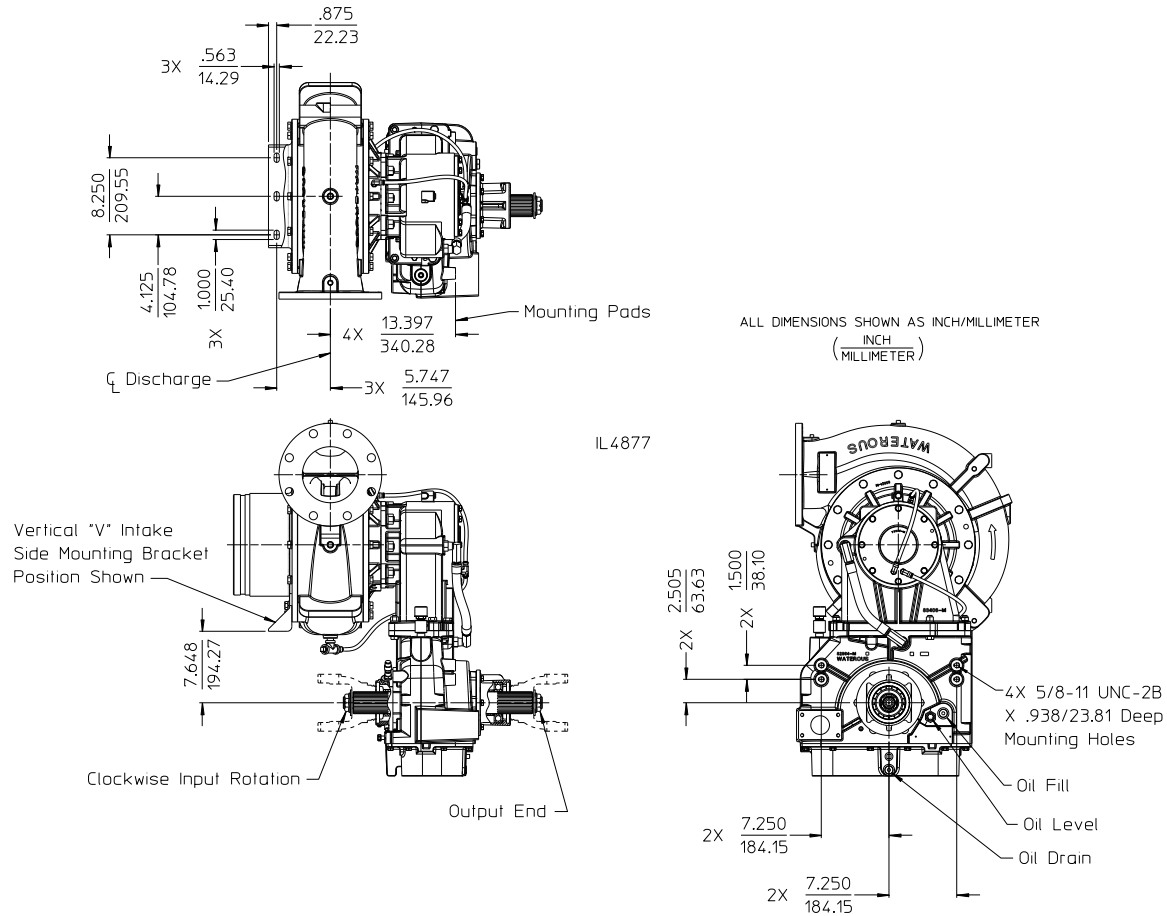

Model CRUC21-2 Mounting Locations

Pump Mounted on Rear (Output Shaft Side) Transmission

Attach brackets to the transmission and the intake adapter. Secure the pump and transmission to the vehicle.

NOTE: Tighten the mounting screws to standard torque specifications

Anti-seize should be applied to the shaft threads before installing end yoke or companion flange. Do not reuse self-locking nuts, torque to 275-325 lb-ft.

Note that the pump discharge may be positioned Up, Right or Left. The intake side mounting bracket may be positioned Vertical or Inverted.

Refer to the configuration of the pump you ordered and pump dimensional drawing for details specific to your pump.

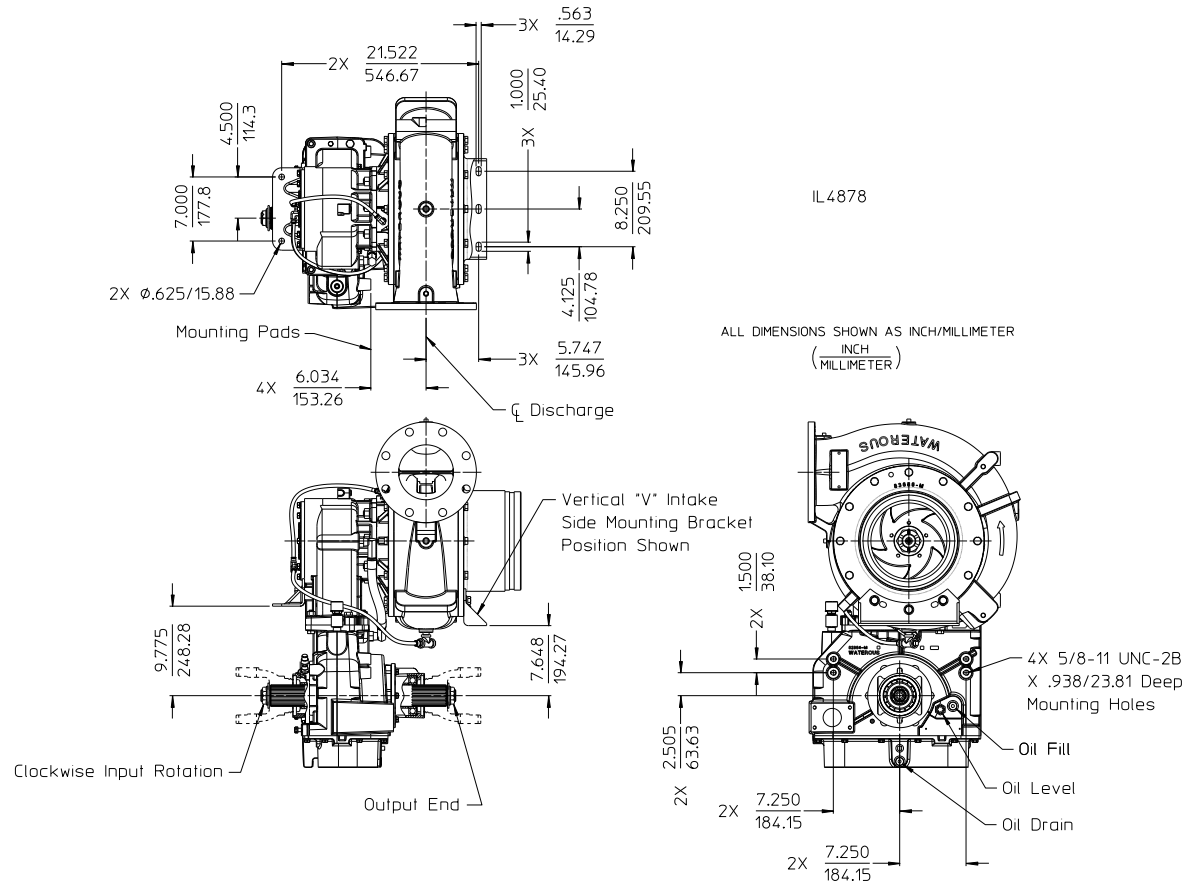

Final Checks

Lubrication

Before operating the pump, add the lubricant specified below, see pages 3 through 14 for fill locations.

Transmission Model	Pump Bearing Housing (Direct Drive Models)	Capacity (Quarts or Liters) (See Note 1)	Lubricant (See Note 2)
QA	-	1-1/2	ATF (All Climates) or For Ambient Temperatures over 90°F/32°C: SAE 20 Oil 300 SSU @ 100°F with service classification SA, SB, SC should be used
QB	-	4-1/2	
QC	-	4	
C21	-	7	
-	CR	1/4	SAE 30 Non-Detergent Oil
	CRU-1	1/4	
	CRU-2	1-1/2	

Notes:

- 1) Capacities shown are approximate quarts or liters, always fill to the bottom of the plug labeled "Oil Level" or sight glass. Quantities listed vary based on ratio and/or mounting orientation.
- 2) Synthetic ATF and oil substitutes are acceptable.

Testing

Perform the tests listed in F-1031, Section 1000. "Centrifugal Fire Pump Principles of Operation, Inspection Tests and Troubleshooting Guide." During the running tests, monitor the smoothness of operation, listen for unusual noises and check for leaks.