

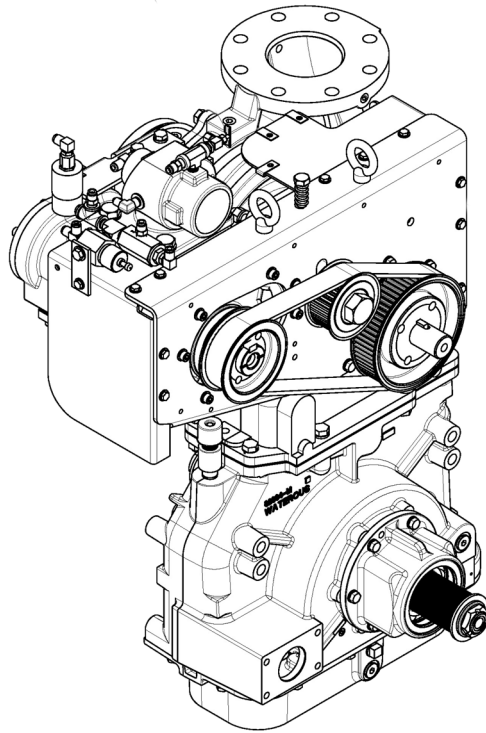

Eclipse GEN 2.0™ CAFSystem, Model 150-ESECL as used with CXC20 Series Fire Pumps Installation Instructions



IL4310



Read through the installation instructions carefully before beginning installation of the Eclipse GEN 2.0™.

NOTE: Instructions subject to change without notice

Table of Contents

Introduction	2
Safety Information	3
Components:	
Compressor:	
Standard & Optional Components	4
Foam Pump.....	5
Eclipse GEN 2.0™ Generators and Controls	6
Schematics:	
System.....	7
Hydraulic	8
Installation:	
General Guidelines	9
Pump and Transmission:	
See Instruction	F-1031, Section 3014
Compressor Components:	
Sump (Oil Reservoir)	10, 11
Sump Vent (Optional)	12
Oil Inject Check Valve (Optional)	13
Oil Cooler	14, 15
Separator Filter	16
Air Filter	17
High Rise Option:	
Auto-Sync Solenoids	18
Air Lines:	
Without High Rise Option	19
With High Rise Option	20
Panel Plates	21
Hose Specifications	22
Initial Power-up	23
CAFS Generators and Controls:	
See Installation Instruction	F-1031, Section 3069
Foam Pump:	
See Installation Instruction	F-1031, Section 2447
Troubleshooting Guide:	
See Operation and Maintenance Instruction	F-1031, Section 2557
Component Drawings:	
Pump and Transmission:	
CXV Models	See DPL82072
CXS Models	See DPL83062
CXN Models	See DPL83348
Compressor Components.....	See DPL83523
Foam Pumps:	
See Installation Instruction	F-1031, Section 2447
Eclipse GEN 2.0™ Generators and Controls	See DPL83637

Introduction

This instruction covers the installation of the Waterous GEN 2.0™ 150-ESECL CAFS system.

New installation tasks include:

- Installing compressor
- Installing compressor sump, separator filter and oil cooler.
- Installing foam pump:
 - See separate instruction:
 - Model Aquis 2.5: F-1031, Section 3061
 - Models Advantus 3E or 6E: F-1031, Section 3062
- Installing CAFS generators and controls, see separate instruction, F-1031, Section 3069

Safety Information

WARNING

Compressed air can be dangerous. Read and understand the operating instructions for the Waterous compressed air foam unit and individual components prior to operating.

WARNING

Discharge outlets that are capped, hose lines that are valved and charged and the air compressor sump may contain compressed air. Relieve all pressure before attempting to remove any caps, fittings and nozzles or to perform maintenance to prevent serious personal injury.

WARNING

Operating the compressed air foam unit with water and compressed air pumped through a discharge without foam concentrate will create a potentially dangerous condition known as “slug flow,” where unmixed pockets of water and air are passed through the nozzle, causing erratic nozzle reaction.

CAUTION

Nozzle reaction force is significantly increased at the time the nozzle valve is opened in compressed air foam operations. Open CAFS nozzles slowly.

CAUTION

Do not use the compressed air foam unit as an air source for SCBA or any breathing air supply

CAUTION

For compressed air foam operations, use only fire hose that is rated at 200 PSI or higher working pressure.

NOTICE

The unit operator should have a thorough understanding of “Boyle’s Law” (The law of compressed gases) prior to operating the compressed air foam unit.

Components – Standard & Optional Compressor Components

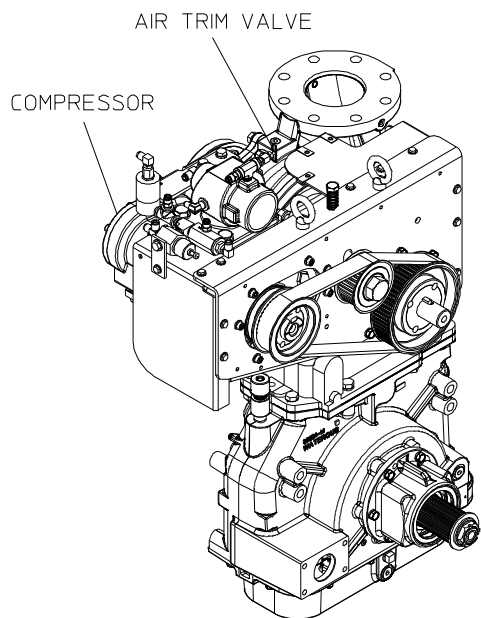

INSTALLED AT FACTORY

IL4310

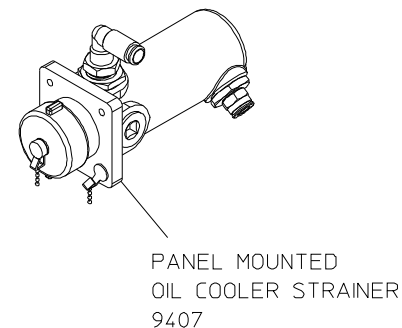
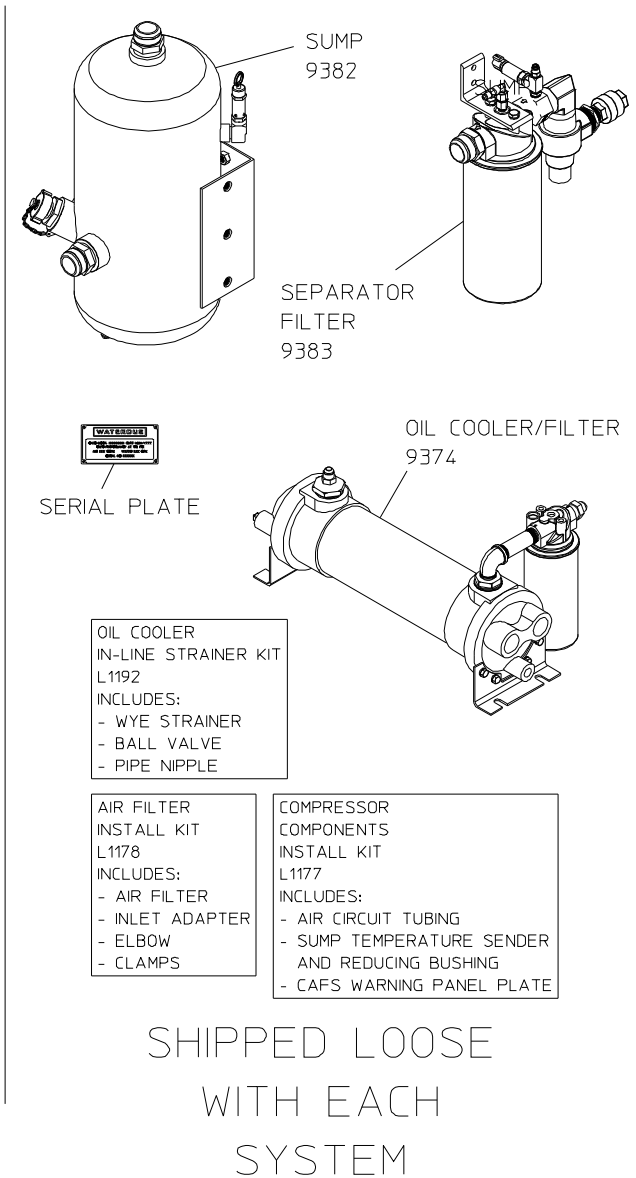

HOSE AND FITTING INSTALL KIT
L1188 (83368)

AUXILIARY AIR DISCHARGE KIT
L1193 (83360)

COMPRESSOR OIL INJECT CHECK VALVE KIT
L1188-5 (83368)

OPTIONAL COMPONENTS
SHIPPED LOOSE

Components – Foam Pump

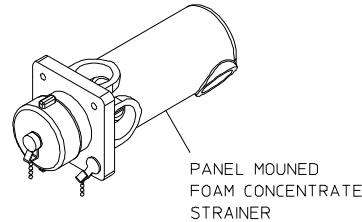
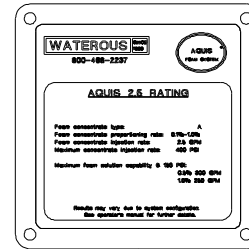
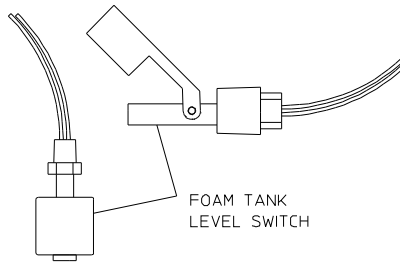
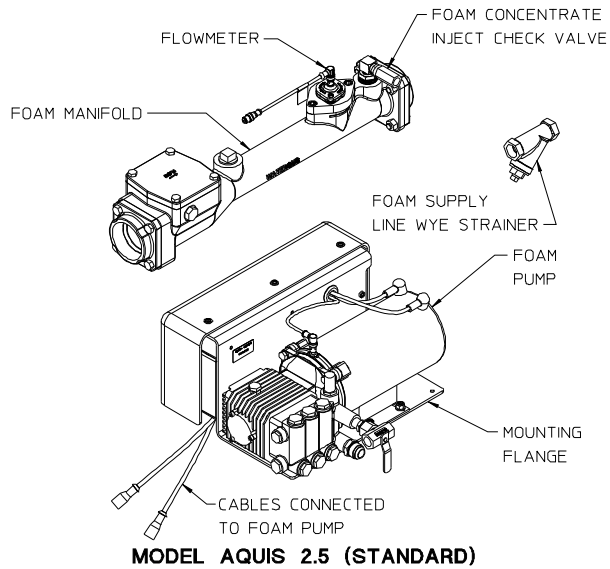

FOAM SUPPLY LINE
HOSE KIT
L1194 (83430)

OVERBOARD FOAM
PICK-UP KIT
83492

DUAL TANK
SELECTOR KIT
83440

FOAM FILL
SYSTEM
83438

FOAM INJECT/BY-PASS
HOSE KIT
L1195 (83430)

OPTIONAL COMPONENTS

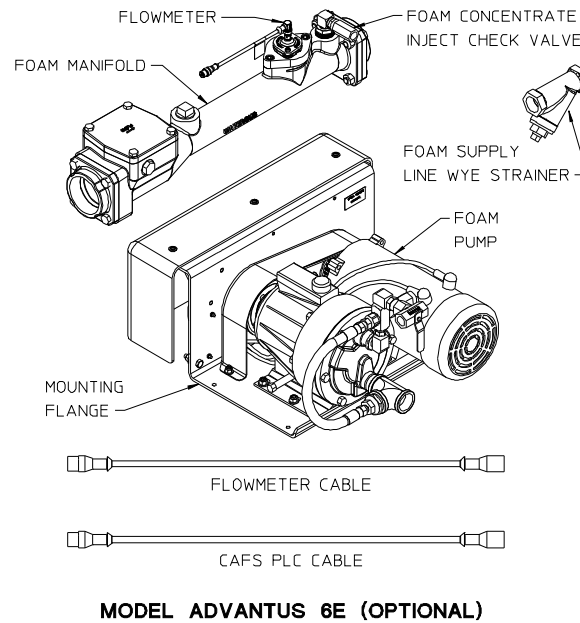
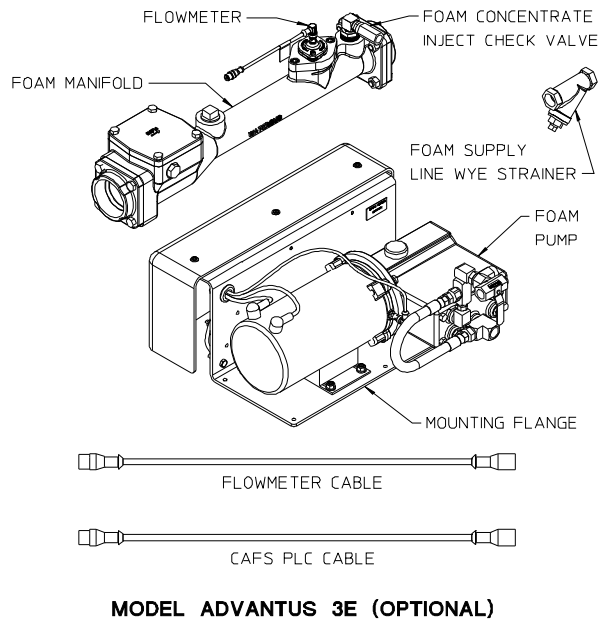

IL4321

Components – Eclipse GEN 2.0™ Generators and Controls

IL4469

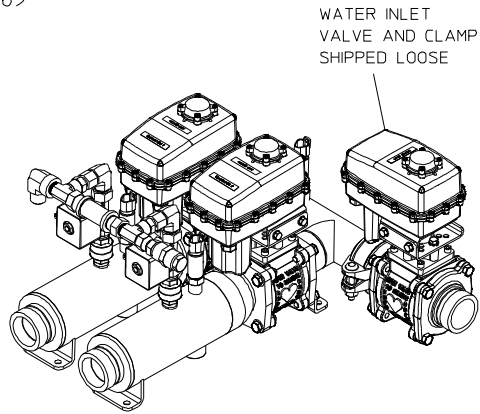

DOUBLE CAFS FOAMULATORS

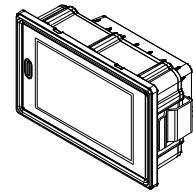

HMI CONTROL PANEL

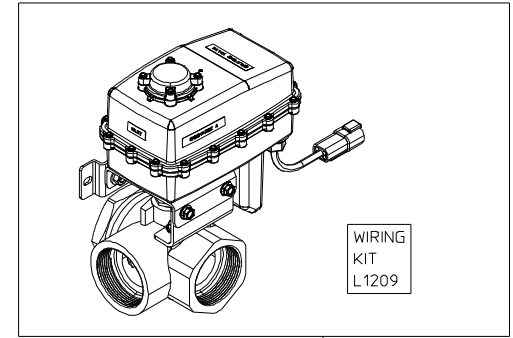

DISCHARGE SPLITTING VALVE, 9439

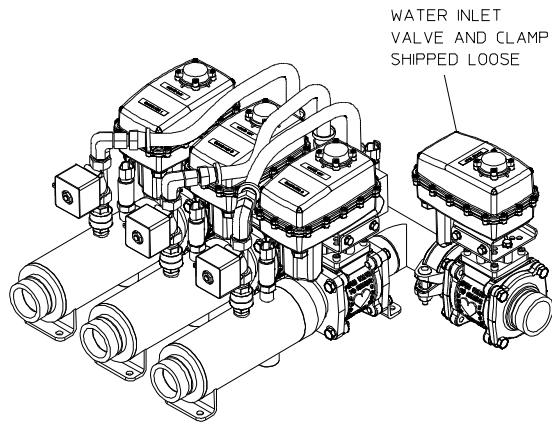

TRIPLE CAFS FOAMULATORS

ALL CABLES CONNECTED
HERE WILL BE INSTALLED
AT THE FACTORY

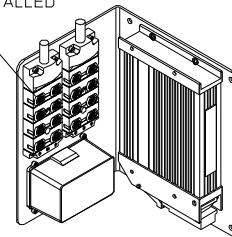

PLC

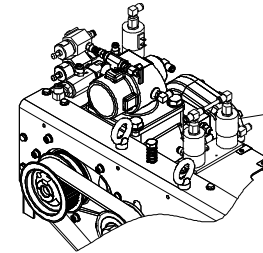

IL4484

OPTIONAL COMPONENTS

Schematic - System

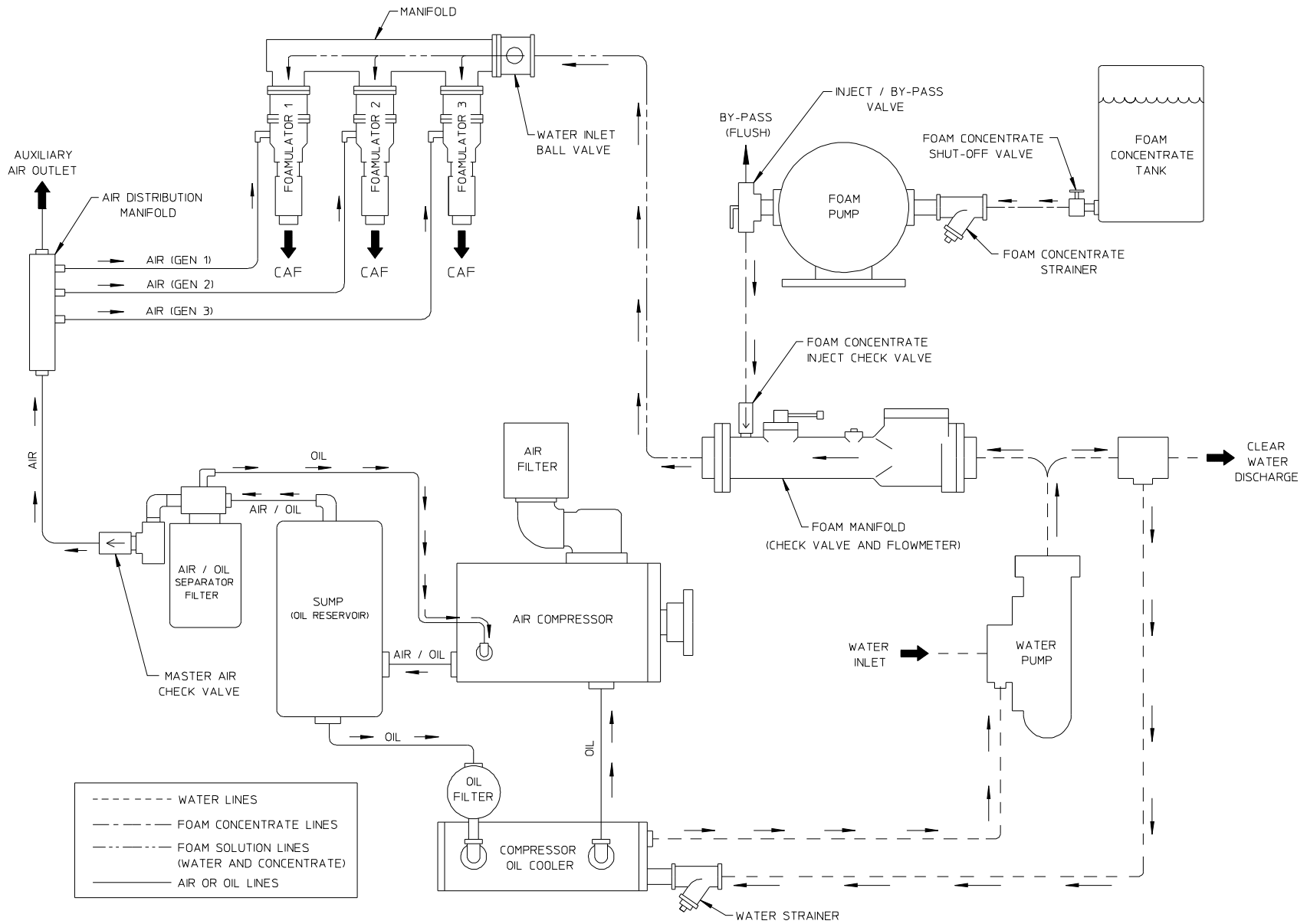

IL4470

Schematic – Hydraulic

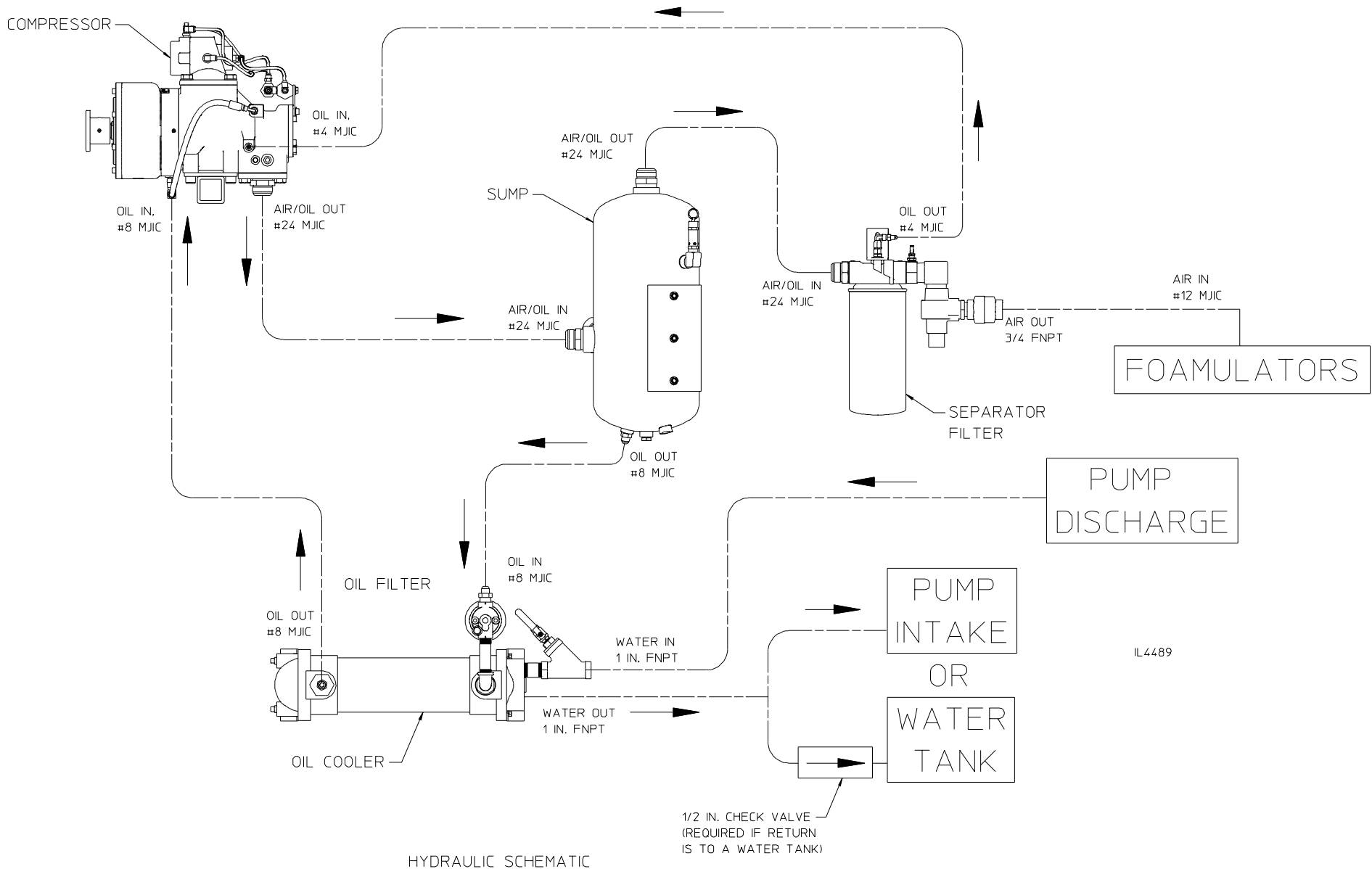

HYDRAULIC SCHEMATIC

IL4489

Installation – General Guidelines

Refer to the System Schematic in this instruction for system components and interconnectivity. Within the guidelines given here, components can be installed wherever there is room for them to be securely mounted.

Components must be bolted to brackets welded to the apparatus frame, or bolted directly to the frame.

CAUTION

Do not damage the vehicle chassis during installation. Check with the vehicle manufacturer to ensure the planned welds and bolts are in acceptable areas.

Make sure electronic devices that may be damaged are disconnected from the chassis before welding.

Allow for access and clearance for routine maintenance such as checking and adding oil, replacing filters, cleaning screens and opening drain valves.

To prevent damage to hydraulic and air lines, or accidentally disconnecting them, run them along the support beams of the pump compartment whenever possible. Bundling and securing with cable ties or other fasteners is a good practice.

Wires, hoses or tubing that passes through metal such as a compartment panel, must have a protective bushing or shield around the edges of the hose to protect against abrasion.

Installation – Sump (Oil Reservoir)

Purpose:

The compressor used in this system is rotary screw type which requires oil for operation. The sump acts as the oil reservoir.

Location:

The sump works best when it is installed so the sight glass opening is below the air discharge outlet on the air compressor, however having the sight glass at the same level is acceptable.

In some cases, finding room for the sump can be difficult. It is acceptable to mount the sump to 12 in. /30 cm. higher than the air compressor. For these installations a check valve should be installed in the line returning oil to the compressor to prevent flooding the compressor with oil. The check valve is an option that can be ordered from Waterous.

For either installation, it is imperative that the sight glass is easily viewed so that the oil level can be monitored and replenished as required.

CAUTION

Waterous will not be responsible for damage to systems where the sump and sight glass are installed such that the oil level cannot be checked or does not display the correct oil level due to improper installation.

Additional Components Required:

You will need to install a temperature sender which is furnished with **Compressor Component Kit L1177** in the bottom of the sump using the reducing bushing furnished.

Mounting:

Use the bracket welded to the sump to attach to the apparatus frame. See drawing DPL83571 for dimensions of sump and bracket.

Hose Connections:

1. Connect the compressor air outlet to the #24 JIC fitting on the side of the sump using 1-3/8" hydraulic hose.
2. Connect the separator filter to the #24 JIC fitting on the top of the sump using 1-3/8" hydraulic hose.
3. Connect the oil cooler filter to the #8 JIC fitting on the bottom of the sump using 1/2" hydraulic hose.
4. See the Hose Specification section of this instruction for hose specifications.

Note that all hoses and fittings are available as an optional kit from Waterous, see drawing DPL83523.

Electrical Conditions:

The temperature sender will be connected to the CAFS Generator wiring, see **Generators and Controls instruction F-1031-3069**.

Drain:

A plug is located in the bottom of the sump for draining oil.

Installation – Sump, (Oil Reservoir) (con't)

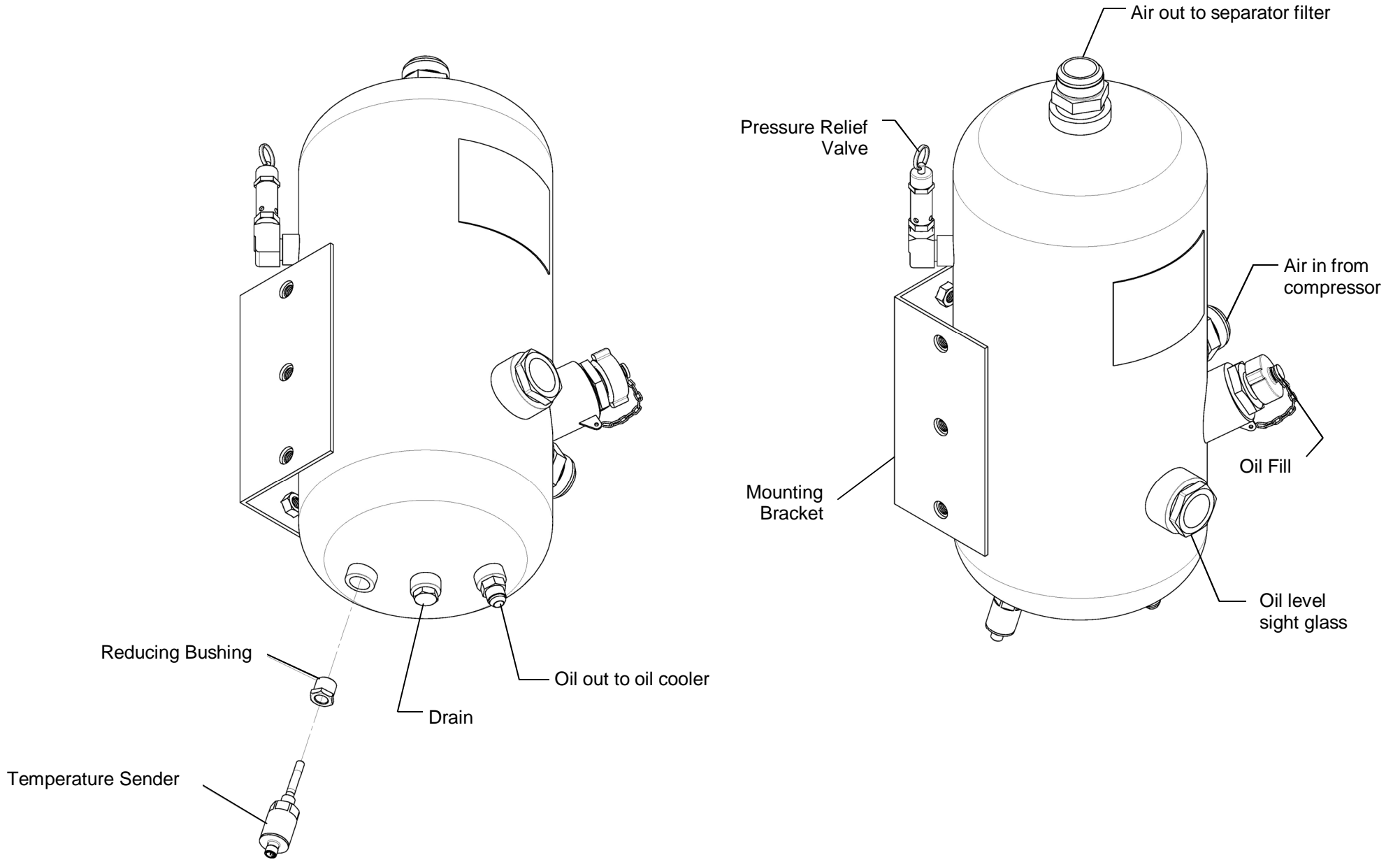

IL4281

Installation – Optional Sump Vent

Purpose:

The sump vent releases compressor pressure to the atmosphere for 10 seconds at compressor start-up to reduce the likelihood of stalling the engine. All components are furnished in kit L1186.

Location:

The sump vent can be located anywhere in the chassis keeping in mind that it must be wired to the circuit that engages the compressor and an air line must be connected to the separator filter.

Mounting:

Use the bracket to attach to the apparatus frame. See drawing DPL83523 for dimensions of sump and bracket.

Electrical Connections:

The Deutsch connector on the sump vent must be wired to the CAFS engage circuit.

Hose Connections:

A 1/2 in. air line must be installed between the sump vent and the separator filter. All tubing and fittings are furnished.

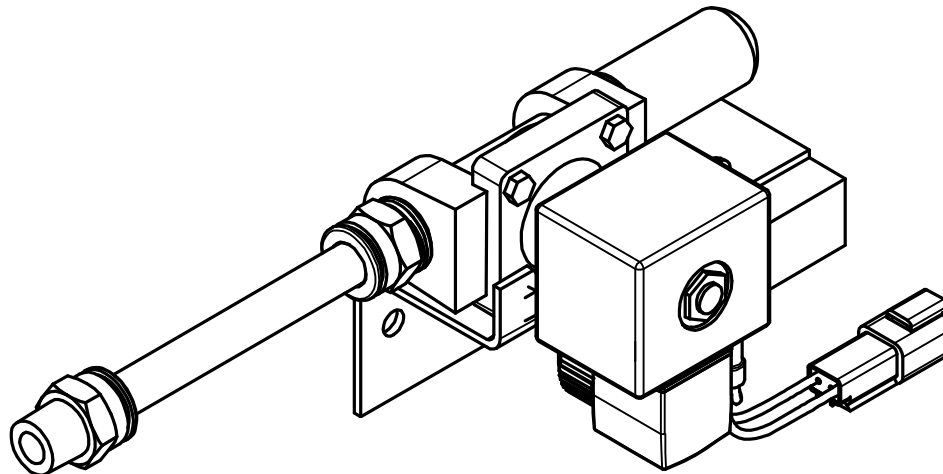

IL4306

Installation – Optional Oil Inject Check Valve

Purpose:

If the sump is mounted with its oil level 12.00 in./304 mm or more above the compressor driveline, a check valve will be required in the oil line from the oil cooler to the compressor. This is necessary to prevent flooding the compressor with oil.

The check valve is an option that can be ordered from Waterous. See drawing DPL83523.

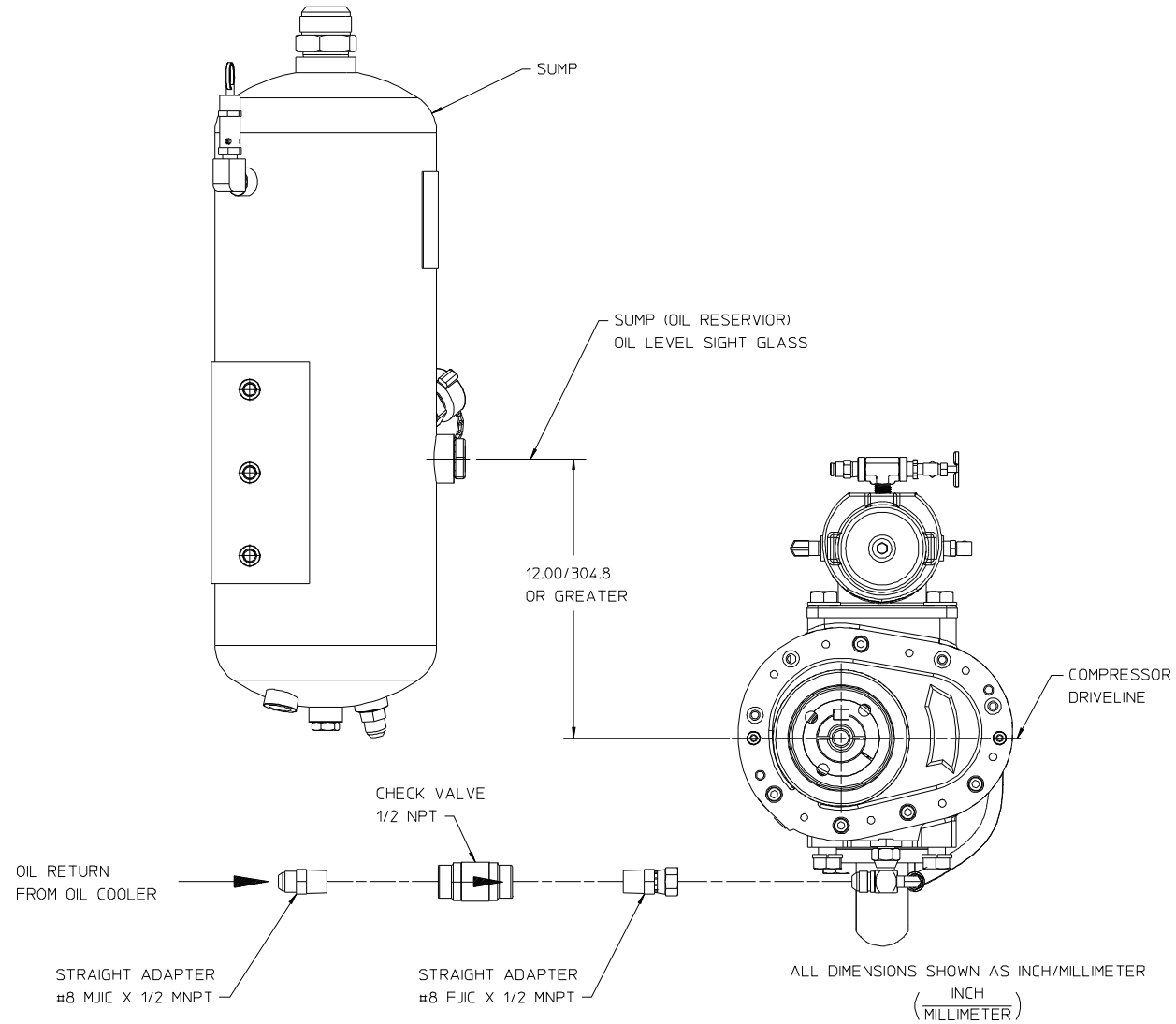

IL4438

OPTIONAL OIL INJECT CHECK VALVE
 REQUIRED WHEN SUMP (OIL RESERVIOR) OIL LEVEL IS.
 12 IN./304.8 mm OR MORE ABOVE COMPRESSOR DRIVELINE

Installation – Oil Cooler

Purpose:

The oil flowing to the compressor from the sump is passed through an oil filter to remove contaminants and then through the cooler which uses water from the pump to cool the oil.

Location:

The cooler should be located so that the strainer screen and oil filter can be accessed for maintenance and the cooler drained after each use.

Open space should be left under the oil filter to allow for removal of the filter. If cooler ordered has a panel mounted water strainer, the strainer screen is accessed at the operator's panel.

Mounting:

The cooler has a right angle mounting bracket on each end oriented for mounting on a horizontal surface. If mounting on a vertical surface, these brackets may be re-oriented on the cooler. Ensure that the drain port is located down (under the inlet ports).

The cooler must be installed horizontally with the drain port at the lowest point. The cooler should have a slight slope towards the drain end.

If necessary to ease the installation, the oil and water inlets and outlets can be reversed.

If relocating the oil filter, note that the filter has a one-way flow. Ensure the flow arrow on the top of the filter is correct.

Hose Connections:

In-Line Strainer:

Install the in-line wye strainer furnished in kit L1192 in the water inlet tap on the cooler. Note that screen in the strainer must be accessed for regular inspection and cleaning.

CAUTION

Waterous will not be responsible for damage due to plugged strainers. Without adequate water flow through the cooler, the compressor will overheat and possibly fail. Removing the screen does not improve water flow as it will allow debris to enter the cooler which can clog the small internal cooler tubes and restrict water flow.

Hose Connections:

Water Lines:

Supply Lines:

The cooler water is supplied by diverting water via fitting (OEM supplied) from the **DISCHARGE** side of the fire pump 1/2 in. I.D. hose should be used to supply the proper flow for the cooling system.

CAUTION

Do not install a shut off valve in the oil cooler water supply line. This could cause the system to overheat and fail and void the manufacturer's warranty.

Return Line, Option 1:

The cooler discharge water may be routed to the booster tank and a check valve installed in the line to prevent backflow from the tank through the cooler. During drafting and hydrant supplied operations, the booster tank may overflow because of the cooler return water. 1/2 in. I.D. hose should be used to supply the proper flow for the cooling system.

Return Line, Option 2:

Route the return line to the inlet side of the pump, In this case, it is not necessary to install an in-line check valve, but it will be necessary for the pump operator to open the tank fill valve during operation to prevent overheating the pump. 1/2 in. I.D. hose should be used to supply the proper flow for the cooling system.

Drain Lines:

The oil cooler has a 3/8 in. NPT tap located on the end of the cooler where water lines are connected. This line can be tied into the pump drain valve or a separate valve used. It is recommended that 1/2 in. I.D. hose be used for the drain line. Waterous does not furnish the hose or separate valve.

The outlet of the drain hose must be lower than the drain tap on the cooler and should be a continuous downward run (no goosenecks) to allow proper drainage.

Oil Line:

Connect the oil cooler filter to the #8 JIC fitting on the bottom of the sump using 1/2 in. hydraulic hose.

See the **Hose Specification** section of this instruction for hose specifications. Note that all hoses and fittings except for the drain line are included in the optional hose and fitting kit available from Waterous. See drawing DPL83523

Installation – Oil Cooler (con't)

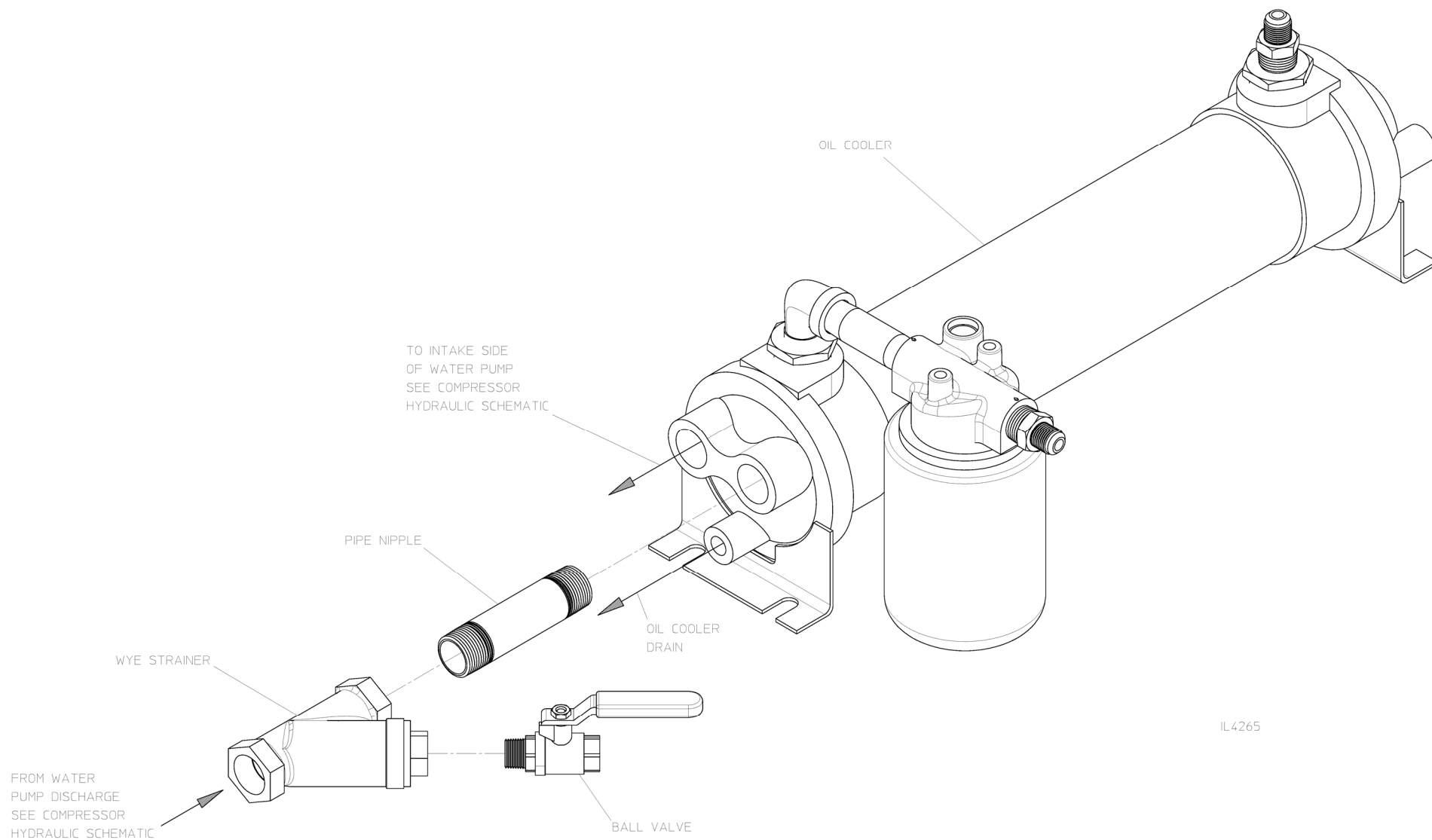

Installation – Separator Filter

Purpose:

The filter removes oil from the air being discharged by the compressor and returns it to the compressor via an oil return (scavenger) hose. It is also the point from which compressed air is obtained for the CAF generators.

Location:

The separator filter can be installed anywhere there is room in the apparatus. Install vertically with the housing up and filter element down. Leave room under the filter to facilitate its removal for maintenance.

Mounting:

Use the angle bracket on the filter to attach to the apparatus frame. See drawing **DPL83571** for dimensions and required maintenance space.

Hose Connections:

Note the flow directions arrows on the top of the filter.

Hydraulic Lines:

1. Connect the intake side to the #24 JIC fitting on the top of the sump using 1-3/8" hydraulic hose.
2. Connect the discharge side 3/4" NPT tap to the #8 JIC fitting on the CAFS Generators using 1/2" air line (2 generators system).
3. Connect the #4 JIC elbow on the top of the filter to the #4 JIC oil return fitting on the air compressor using 1/4" hydraulic hose.

See the hose specification section of this instruction for hose specifications.

Note that all hoses and fittings are available as an optional kit from Waterous, see drawing DPL83523.

Air Line Connection:

The push-on fitting on the top of the filter is to be connected to the air compressor Pressure Modulating Control (PMC). See Air Line section of this instruction.

Electrical Connection:

The pressure switch will be connected to the CAFS Generator wiring, see **Generator and Controls Instruction F-1031-3069**.

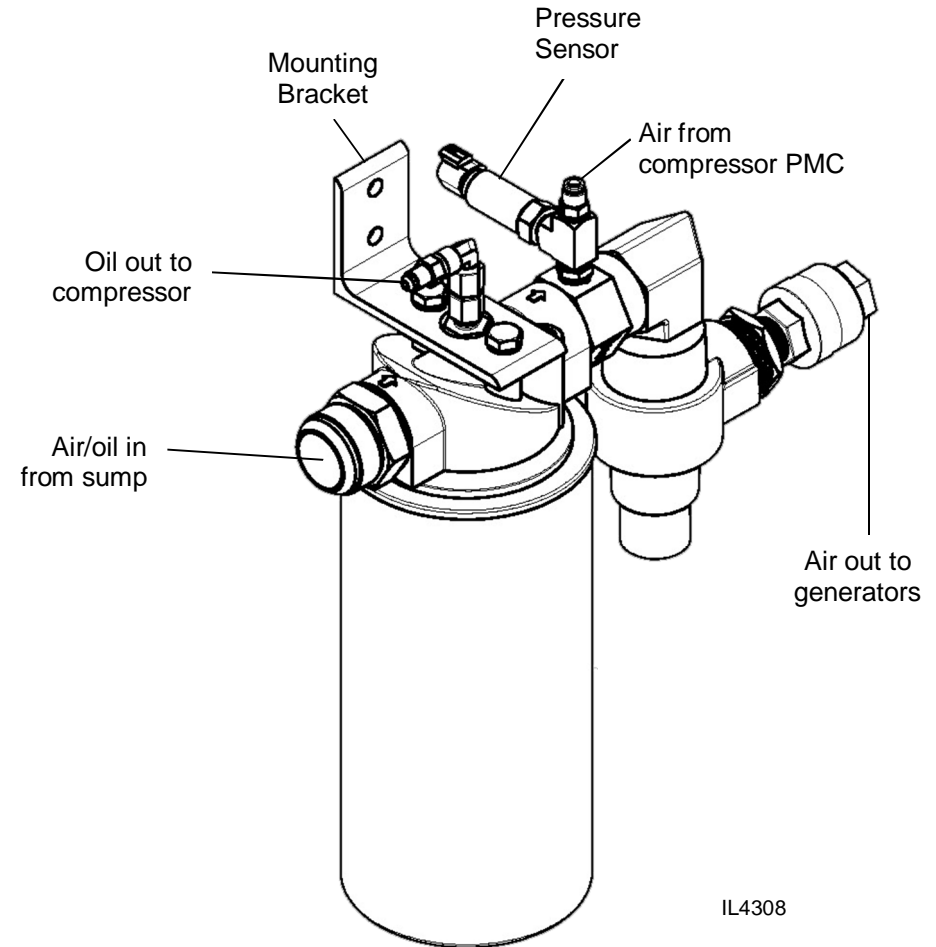

Installation – Air Filter

Purpose:

The air filter prevents any contaminants such as dust and sand from entering the compressor.

Location:

The air filter is to be installed on the air compressor inlet. The air intake area should be unobstructed. Note that the filter is a maintenance item, so it should be accessible in the apparatus with adequate space for removal.

Mounting:

Use the inlet adapter furnished along with rubber elbows and clamps furnished with install kit L1178. See drawing DPL83523 for dimensions.

Plumb it as though it were an engine air inlet, do not use flexible exhaust tubing or any material that water and dirt can easily penetrate. The tubing run should be as short and straight as possible.

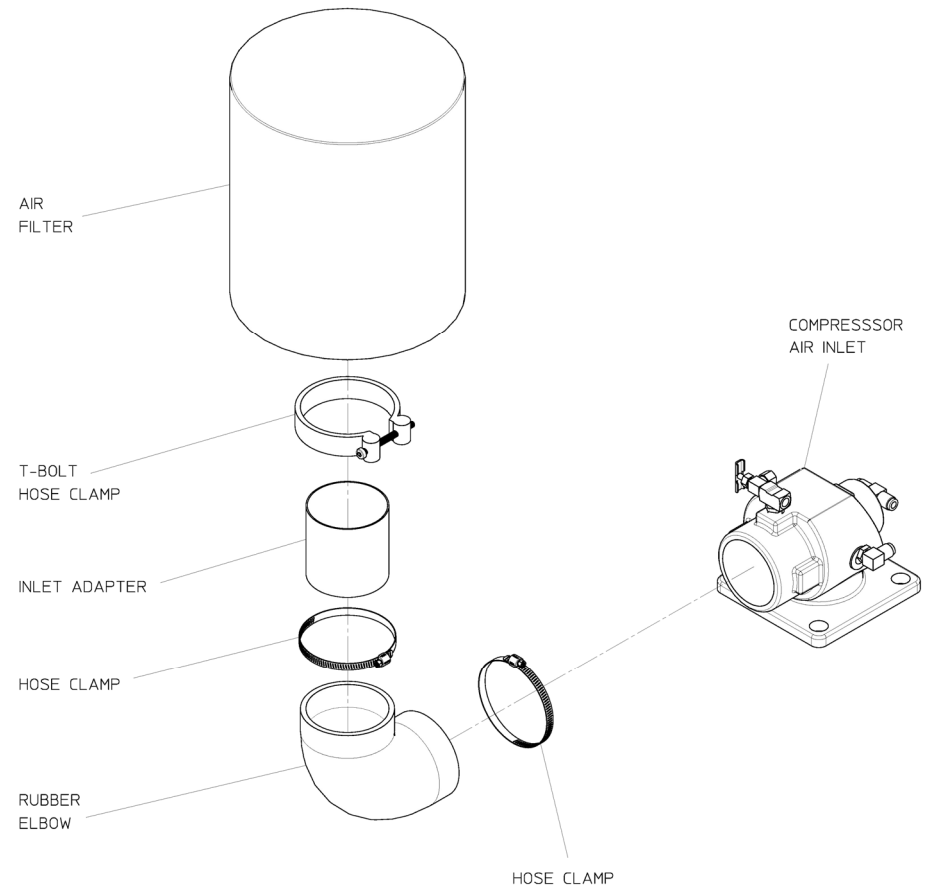

IL4226

AIR FILTER INSTALLATION

Installation – High Rise Option, Auto-Sync Solenoids

Air Line Connections:

Use black air line tubing furnished with **Compressor Component Kit L1177**.
See **Air Lines – With High Rise Option** for connections.

Electrical Connections:

Each solenoid will be connected to the CAFS Generator wiring.
See **Generators and Controls Instruction F-1031-3069**.

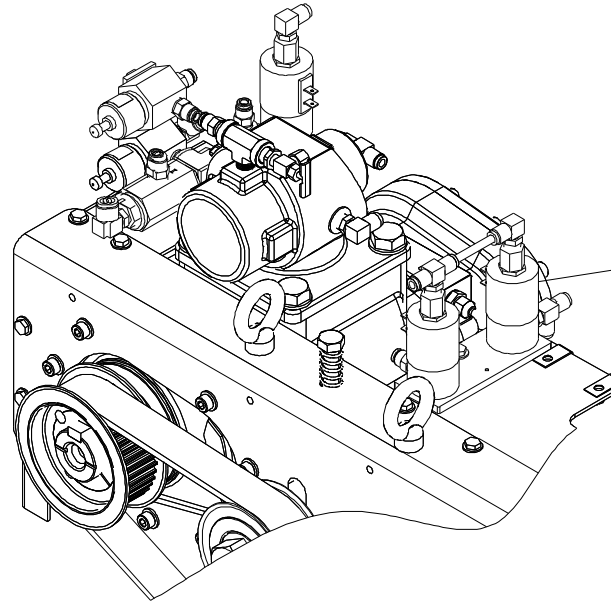

AUTO SYNC FOR
ECLIPSE GEN 2.0
HIGH RISE OPTION
FURNISHED WITH
COMPRESSOR

IL4484

Installation – Air Lines, Without High Rise Option

Air Line Connections:

1. Use black 1/4" air line tubing furnished with **Compressor Component Kit L1177**.
2. Connect the separator filter to PMC Tee mounted on the compressor.
3. Discard the red and yellow tubing in the kit as it is not used.

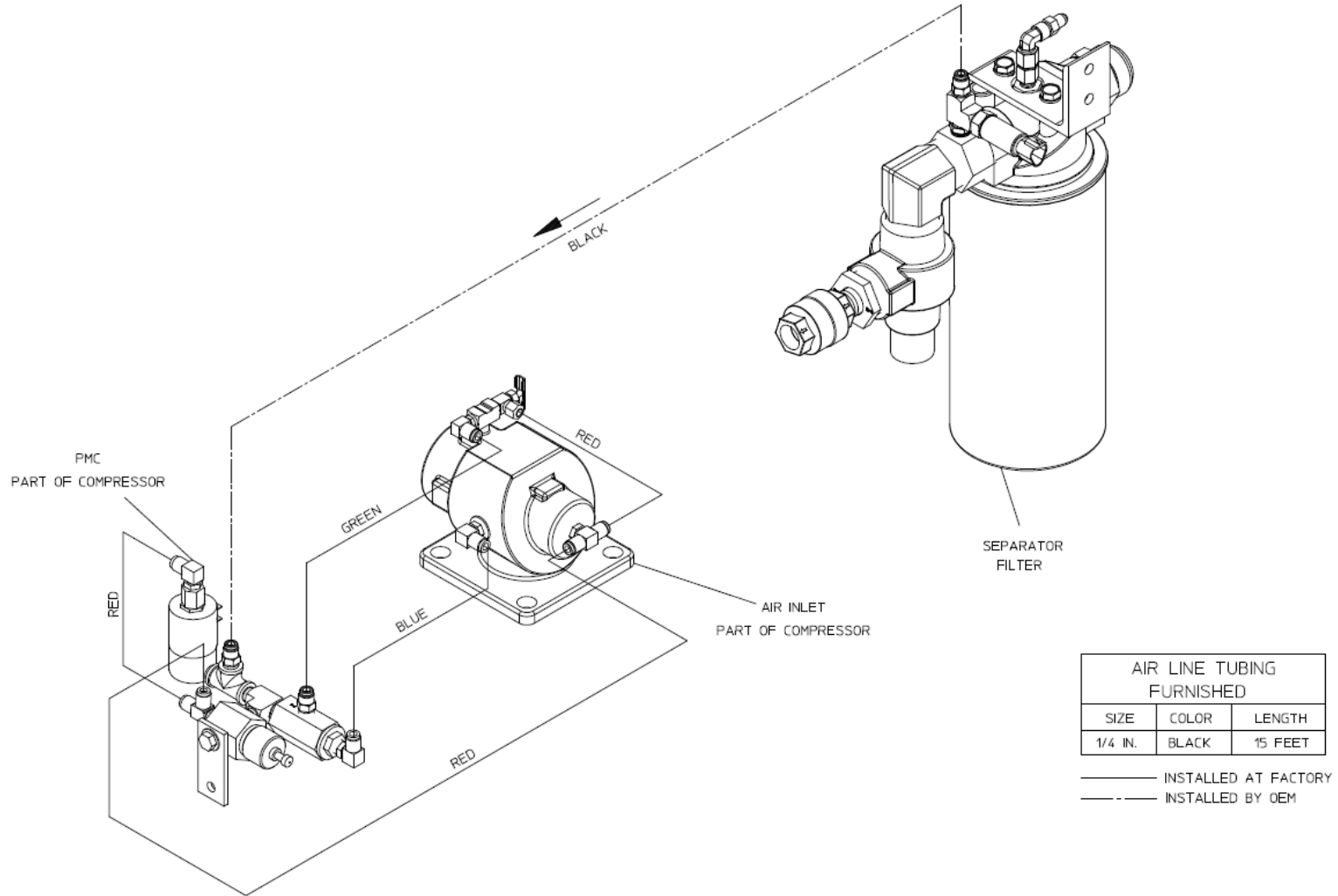

IL4271

Installation – Air Lines, With High Rise Option

Air Line Connections:

1. Use black, yellow and red 1/4 in. air line tubing furnished with **Compressor Component Kit L1177**.
 - a. Use the black tubing to connect the Separator Filter to the Auto-Sync Solenoid labeled “Normal Pressure.”
 - b. Use the yellow tubing to connect the Compressor PMC to the Auto-Sync Solenoid labeled “High Rise Pressure.”
 - c. Use the red tubing to connect the Compressor PMC to the Auto-Sync Solenoid labeled “High Rise Pressure.”

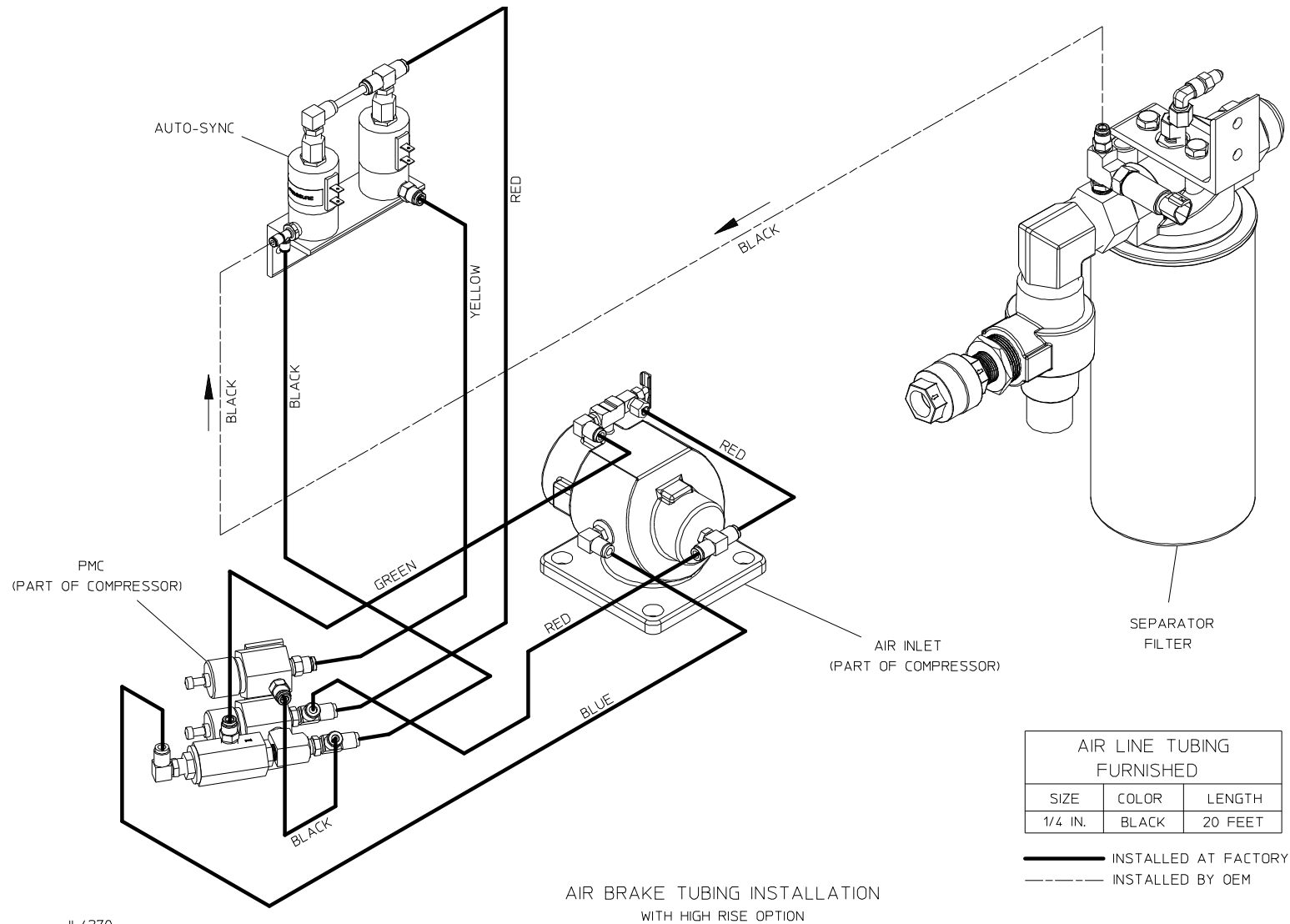

IL4270

Installation – Panel Plates

Location:

Two panel plates require installation on the operator's panel:

- CAFS Warning Plate furnished with **Compressor Component Kit L1177**.
- Serial Plate shipped loose with the compressor.

Mounting:

Use four screws to install each panel plate (not furnished by Waterous).

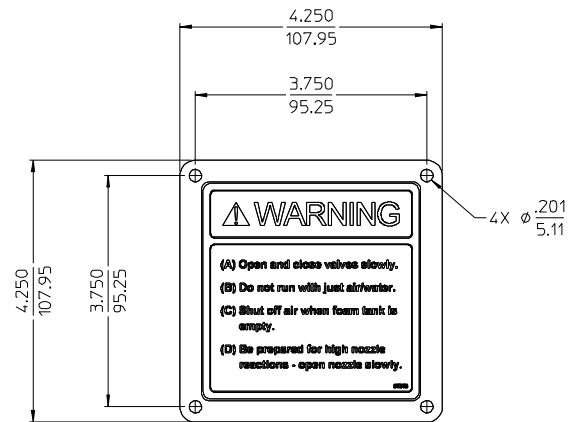

CAFS WARNING

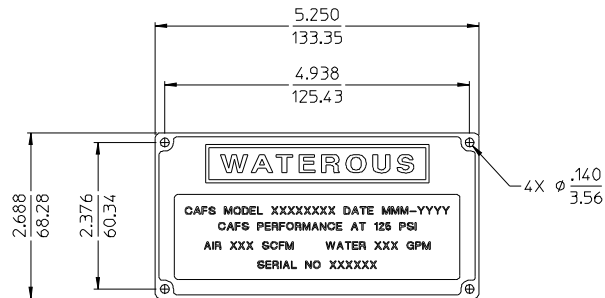

SERIAL PLATE

PL83522.6

Installation – Hose Specifications

Hydraulic Oil (and air):

For compressor hydraulic system, use a hose that complies with SAE J517, 100R1 or 100R5 as a minimum.

Air:

For air compressor control circuit and gauging, 1/4" OD air brake tubing is typically used. Tubing such as Eaton Synflex Eclipse or equivalent is suggested. The tubing shall comply with SAE J844 Type A.

For compressed air distribution, "push-on" type hose is typically used. An H101 or H201 general purpose hose with a working pressure rating of 300 psi or better is acceptable. The hose shall also have a minimum burst pressure of 4 times rated working pressure (4 x 300 = 1200 psi).

Water:

For cooling water hose or any hose connected to the discharge of the pump, use a hose that complies with SAE J517, 100R3 as a minimum.

General practice factors to avoid with hose (and tubing):

- Bending the hose to less than the minimum specified bend radius.
- Pulling, twisting, crushing or kinking.
- Routing hose over sharp edges, abrasive or hot surfaces.
- Pressure spikes in excess of rated working pressure.

NOTE: All hoses and fittings are available as an optional kit from Waterous. See drawing DPL83523.

Initial Power-up

Assembly Checks:

- Remove all tools, shop towels, hose trimmings and other debris from the apparatus compartment.
- Double check all hydraulic, air and water lines against schematics, checking to make sure each connection is tight and that the hose or tubing is fully inserted into fittings.
- Check that all unused inlets have the shipping plugs removed and replaced with appropriate plugs or caps.
- Make sure all drain valves are closed.
- Make sure the fire pump is operating properly and that water flows through the compressor oil cooler.
- Make sure the foam pump is operating properly.

Lubrication:

Fill the sump with hydraulic oil until the level 1/2 way up the sight glass. Use ISO AW68, low foaming/anti-foaming hydraulic oil.

Note that the level will need to re-checked and additional oil added to compensate for oil that fills the hydraulic lines and compressor after the initial compressor run.

Air Circuit Adjustment:

The air trim valve located on the compressor air inlet is factory set at three full turns open from its closed position. If necessary to reset, loosen lock nut, turn to fully close and then open three full turns. Tighten locknut after adjustment. See page 4 for location of air trim valve.

Power-up:

CAUTION

Compressed air can be dangerous. Make sure the pressure is allowed to bleed down to atmospheric pressure before opening any connections or valves.

Check ALL fluids in the entire vehicle before initial power-up.

1. Remove the compressor air filter piping and pour 8 to 16 ounces of hydraulic oil into the air inlet.
2. Replace the air filter piping.
3. Start the vehicle and engaged the CAFSystem.
4. Check for leaks by listening for hissing noises at the fittings.
5. Shut the system off and allow for air pressure to bleed off.

Re-check the sump oil level and add additional oil added to compensate for oil that fills the hydraulic lines and compressor after the initial compressor run.