

# CM/CMU Series Fire Pumps

# Overhaul Instructions

Form No.	Section	Issue Date	Rev. Date
F-1031	4212	06/30/95	3/25/21

## Table of Contents

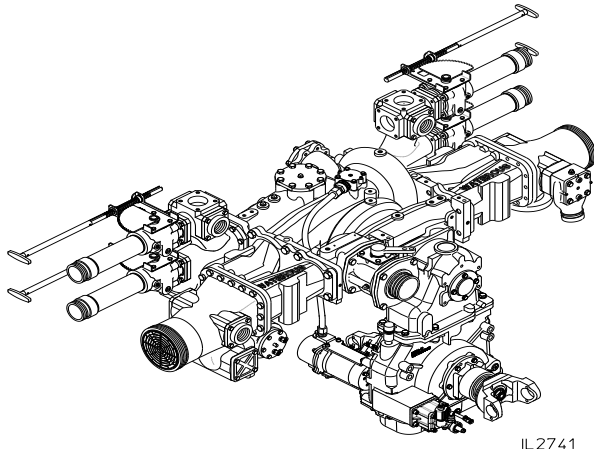

IL 2741

Type of Overhaul	Pump Drive	See	
		Table	Page
Complete Disassembly of Pump	Transmission Mounted Directly to the Rear of the Pump	1	3
	Transmission Mounted Directly to the Front of the Pump	2	4
	Direct Drive (The pump is driven by a remotely mounted transmission or P.T.O., the pump is turned by an end yoke on the impeller shaft.)	3	5
Replacement of Packing or Mechanical Seals Without Disassembling the Pump	Direct Drive or Transmission Mounted Directly to the Pump	4	6
Removal and Installation of Transfer Valve	Direct Drive or Transmission Mounted Directly to the Pump	5	7



Visit us at [www.waterousco.com](http://www.waterousco.com)

# Safety Information

Please read through the safety information and operating instructions carefully before using your Waterous Fire Pump.

## WARNING

Death or serious personal injury might occur if proper operating procedures are not followed. The pump operator, as well as individuals connecting supply or discharge hoses to the apparatus must be familiar with these pump operating instructions as well as other operating instructions and manuals for the apparatus, water hydraulics and component limitation.

## WARNING

### **Pressure Hazard. May result in personal injury.**

Prior to connection or removal of hoses, caps or other closures with pump intake or pump discharge connections, relieve pressure by opening drains or bleeder valves. Bleeder valves should also be used while filling a hose connected to an intake with water.

## WARNING

### **Scalding Water Hazard. May result in serious burns.**

When operating the pump, be sure to open at least one discharge valve slightly to prevent the pump from overheating. If the pump runs for a few minutes completely closed, it may heat the water enough to scald someone when the valve is opened. Overheating can damage the packing, seals and other pump parts. If the apparatus builder has installed a bypass system or other provision designed to prevent overheating, opening a discharge valve may be unnecessary.

## WARNING

### **Unexpected Truck Movement. May result in serious personal injury or death.**

Failure to properly shift transmission in accordance to the transmission operating instructions may result in unexpected truck movement which may result in serious personal injury or death.

## WARNING

### **Rotating Parts Hazard or Unexpected Truck Movement. May result in serious personal injury or death.**

Stop the engine, set parking brake and chock the wheels before going under the truck to adjust packing or to check packing gland temperature.

## WARNING

### **Packing Gland and Pump Body Temperature Hazard. May result in serious burns.**

Heat is dissipated through the cross-section of the packing, transferring the heat to the packing gland and pump body.

**Table 1: Complete Disassembly of Transmission Mounted Pumps  
(For Transmissions Mounted Directly to the Rear of the Pump)**

Overhaul Operation			See Page	
			Pumps with Mechanical Seals	Pumps with Packing
Safety Information			2	2
General Information			8	8
Removal Of:	Transmission		9	9
	Intake Adapters		11	11
	Impeller Shaft Assembly		12	12
Disassembly of Impeller Shaft Components	Outboard Bearing Removal	Prior to April 21, 2006	14, 19, 20	16, 19, 20
		After April 21, 2006	15, 21	17, 21
	Interstage Seal and Seal Housing	Removal	26	27
		Check	29	30
	Impeller Removal		28	28
Reassembly of Impeller Shaft Components	Cooling Line Check		29	30
	Installing Undersize Wear Rings		31, 32	31, 32
	Impeller / Wear Ring Installation		33, 34	33, 34
	Seal Housing Installation		26	27
	Mechanical Seal Installation		41, 42	-
	Packing	Installation	-	44
		Adjustment	-	44
	Outboard Bearing Installation	Prior to April 21, 2006	14, 22	16, 22
		After April 21, 2006	15, 23	17, 23
	Installing Impeller Shaft Assembly		35	35
Installing Body Hardware		37	37	
Installation of Transmission			9	9
Vacuum Test			45	45

**Table 2: Complete Disassembly of Transmission Mounted Pumps  
(For Transmissions Mounted Directly to the Front of the Pump)**

Overhaul Operation		See Page		
		Pumps with Mechanical Seals	Pumps with Packing	
Safety Information		2	2	
General Information		8	8	
Removal Of:	Transmission	10	10	
	Intake Adapters	11	11	
	Impeller Shaft Assembly	13	13	
Disassembly of Impeller Shaft Components	Outboard Bearing Removal	15, 21	17, 21	
	Interstage Seal and Seal Housing	Removal	26	
		Check	29	
	Impeller Removal	28	28	
Reassembly of Impeller Shaft Components	Cooling Line Check	29	30	
	Installing Undersize Wear Rings	31, 32	31, 32	
	Impeller / Wear Ring Installation	33, 34	33, 34	
	Seal Housing Installation	26	27	
	Mechanical Seal Installation	41, 42	-	
	Packing	Installation	-	44
		Adjustment	-	44
	Outboard Bearing Installation	15, 23	17, 23	
	Installing Impeller Shaft Assembly	36	36	
Installing Body Hardware	37	37		
Installation of Transmission		10	10	
Vacuum Test		45	45	

### Table 3: Complete Disassembly of Direct Drive Pumps

Overhaul Operation			See Page	
			Pumps with Mechanical Seals	Pumps with Packing
Safety Information			2	2
General Information			8	8
Removal Of:	Intake Adapters		11	11
	Impeller Shaft Assembly	Rear Drive	12	12
		Front Drive	13	13
Disassembly of Impeller Shaft Components	Outboard Bearing Removal	Front or Rear Drive w/o Tachometer	14	16
		Front Drive with Tachometer	18	18
	End Yoke Removal on Drive End	Front Drive with Tachometer	24	24
		Front or Rear Drive w/o Tachometer	25	25
	Seal Housing Removal		26	27
	Impeller Removal		28	28
	Interstage Seal and Seal Housing Check		29	30
Reassembly of Impeller Shaft Components	Installing Undersize Wear Rings		31, 32	31, 32
	Impeller / Wear Ring Installation		33, 34	33, 34
	Seal Housing Installation		26	27
	Mechanical Seal Installation		41, 42	-
	Packing	Installation	-	44
		Adjustment	-	45
	Outboard Bearing Installation	Front or Rear Drive w/o Tachometer	14	16
		Front Drive with Tachometer	18	18
	End Yoke Installation on Drive End	Front Drive with Tachometer	24	24
		Front or Rear Drive w/o Tachometer	25	25
	Installing Impeller Shaft Assembly	Rear Drive	35	35
		Front Drive	36	36
Installing Body Hardware		37	37	
Vacuum Test			45	45

## Table 4: Replacement of Packing / Mechanical Seal Without Disassembly the Pump

Pump Driven By	Type of Seal	Operation		See Page	
<b>Transmission</b> (Mounted Directly to the Pump)	Mechanical Seals	Safety Information		2	
		General Information		8	
		Removal Of:	Transmission	Mounted to Rear of Pump	9
				Mounted to Front of Pump	10
		Removal Of:	Outboard Bearing	Prior to 4/21/2006	14, 19, 20
				After 4/21/2006	15, 21
		Seals		38, 39, 40	
		Cooling Line Check		29	
		Installation Of:	Seals		41, 42
			Outboard Bearing	Prior to 4/21/2006	14, 22
	After 4/21/2006			15, 23	
	Transmission		9		
	Vacuum Test		45		
	Packing	Safety Information		2	
		General Information		8	
Packing Removal		43			
Cooling Line Check		30			
Packing		Installation		44	
		Adjustment		44	
Vacuum Test		45			
<b>Direct Drive</b> (Pump is driven by a remotely mounted transmission or P.T.O. The pump is turned by an end yoke on the impeller shaft)	Mechanical Seals	Safety Information		2	
		General Information		8	
		Removal Of:	Outboard Bearing	With Tachometer	18
				Without Tachometer	16
			Drive End Yoke	With Tachometer	24
				Without Tachometer	25
		Seals		38, 39, 40	
		Cooling Line Check		29	
		Installation Of:	Seal Installation		39, 40
			Outboard Bearing Installation		14, 22
	Drive End Yoke		Front Drive with Tachometer	24	
		Front or Rear Drive without Tachometer	25		
	Cooling Line Check		29		
	Packing	Safety Information		2	
		General Information		8	
		Packing Removal		43	
		Cooling Line Check		30	
Packing		Installation		44	
Packing		Adjustment		44	
Vacuum Test		45			

**Table 5: Removal / Replacement of Transfer Valve**

Date of Pump	Actuator			Overhaul Operation		See Page
	Style	Mounting	Operation			
After January 1, 2000	Rotary	Bottom	Manual	Actuator	Removal From Pump	46
					Installation in Pump	
					Overhaul	
			Transfer Valve	Removal From Pump	50, 51, 52, 53	
				Installation in Pump		
				Overhaul		F-1031, Section 2315
		Electric Motor	Actuator	Removal From Pump	47	
				Installation in Pump		
				Overhaul		F-1031, Section 2315
			Transfer Valve	Removal From Pump	50, 51, 52, 53	
				Installation in Pump		
				Overhaul		F-1031, Section 2315
		Top	Manual	Actuator	Removal From Pump	48
					Installation in Pump	
					Overhaul	
			Transfer Valve	Removal From Pump	50, 51, 52, 53	
				Installation in Pump		
				Overhaul		F-1031, Section 2315
Electric Motor	Actuator	Removal From Pump	49			
		Installation in Pump				
		Overhaul		F-1031, Section 2315		
	Transfer Valve	Removal From Pump	50, 51, 52, 53			
		Installation in Pump				
		Overhaul		F-1031, Section 2315		
Prior January 1, 2000	Reciprocating	Bottom	Manual	Actuator	Removal From Pump	54
					Installation in Pump	
					Overhaul	
			Transfer Valve	Removal From Pump	59, 60, 61	
				Installation in Pump		
				Overhaul		F-1031, Section 2315
		Electric Motor	Actuator	Removal From Pump	55	
				Installation in Pump		
				Overhaul		F-1031, Section 2315
			Transfer Valve	Removal From Pump	59, 60, 61	
				Installation in Pump		
				Overhaul		F-1031, Section 2315
		Top	Manual	Actuator	Removal From Pump	56
					Installation in Pump	
					Overhaul	
			Transfer Valve	Removal From Pump	59, 60, 61	
				Installation in Pump		
				Overhaul		F-1031, Section 2315
Electric Motor	Actuator	Removal From Pump	57, 58			
		Installation in Pump				
		Overhaul		F-1031, Section 2315		
	Transfer Valve	Removal From Pump	59, 60, 61			
		Installation in Pump				
		Overhaul		F-1031, Section 2315		

---

## General Overhaul Information

---

### ***Tools and Equipment***

The following tools and equipment may be needed to overhaul a pump:

1. Usual automotive mechanic's hand tools.
2. An arbor press for assembling or disassembling components.
3. An engine lathe for turning impeller hubs.
4. A suitable hoist and slings.
5. Torque capability up to 325 lb-ft.

While no special tools and equipment are required, a few special items are illustrated or described so the mechanic can make them or they are available from the apparatus manufacturer or the Waterous Company. These special items are not absolutely necessary, but they will make the mechanic's work much easier.

### ***Preliminary Testing***

Before disassembling a pump, test it thoroughly, if possible, and record the results. A comparison of this test with periodic tests recommended in form F-1031, Section 1000 can often reveal specific pump troubles. Excessive speed, for instance, indicates that impellers and/or wear rings are probably worn. For a two stage pump in series, excessive speed may indicate a worn transfer valve or interstage seal, leaking flap valve or a malfunctioning relief valve.

### ***Cleaning***

The continued satisfactory operation of a pump depends to a great extent upon the cleanliness of its internal parts. Sand, dirt or other abrasive material will wear gears and related parts. Before disassembling a pump for repairs, be sure to clean its exterior. Make sure the working space, benches and tools are clean. Use only clean, lint-free cloths to wipe off components. Before reassembling a pump or its components, be sure to clean them thoroughly.

### ***Pump Bodies, Impellers and Transfer Valves***

Flush out these components and related parts with clean water. Use a stiff brush to remove loose scale, caked sediment, etc. Be sure to remove all traces of old gaskets. Examine pump bodies, covers, adapters and fittings for cracks, severe corrosion or other damage. Almost all damage to these parts results from improper use or maintenance, or from freezing. Replace defective parts.

### ***Bearings, Gaskets, Seals and O-rings***

Parts of this nature are frequently damaged during removal or disassembly. In addition, they sometimes deteriorate or lose their effectiveness because of age or misuse. Replacing these parts whenever overhauling a pump is a good policy.

### ***Impeller Shafts***

Examine shaft for severe scratches, grooves or corrosion - especially under packing or mechanical seals. If scratches are not severe, and are not under packing and seals, clean them with a fine-cut file. Grooves are usually permissible if they are not sharp or too deep. Even slight longitudinal scratches will cause leaks and should be removed.

### ***Installing Ball Bearings***

Most Waterous pumps are designed so that ball bearings fit tightly on their shafts and have relatively loose fits in the bearing housings. When mounting these bearings on shafts, always apply force to the inner races. When bearings have a tight fit in the housings, and a heavy force is necessary to install them, be sure to apply force only to the outer bearing races. For either type of fit, applying force to the wrong bearing race may damage the balls and race.

### ***Installing Body Gaskets***

To provide added sealing for gaskets between bodies and intake adapters, coat both sides of these gaskets with a suitable sealant. A compound such as Permatex Super 300 is recommended for this application. Be sure all traces of previous gaskets and sealant are removed before installing new gaskets.

### ***End Yoke and Companion Flange Nuts***

Do not reuse self-locking nuts. Apply lubrication oil to the threads before removing. Apply anti-seize to the threads before installing a new self-locking nut.



## Transmission Removal / Installation

(Transmission Mounted Directly to the Rear of the Pump)

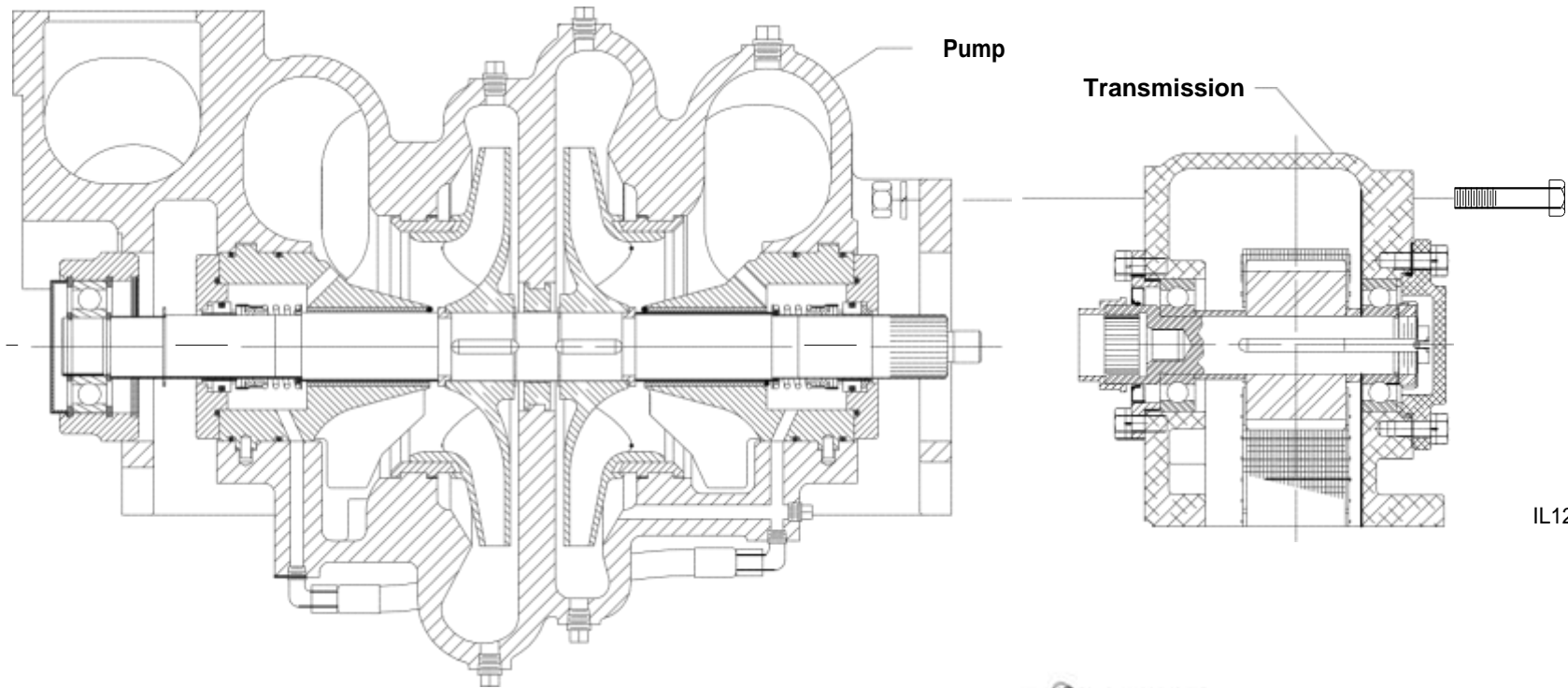

IL1206

1. Remove the four cap screws and lock washers that attach the transmission to the pump.
2. Apply Loctite #242 (blue) to threads when transmission is reattached to the pump. Torque to 85 lb-ft.
3. Use the jacking screw holes to separate the transmission from the pump body.
4. Support transmission and pull straight back from pump.

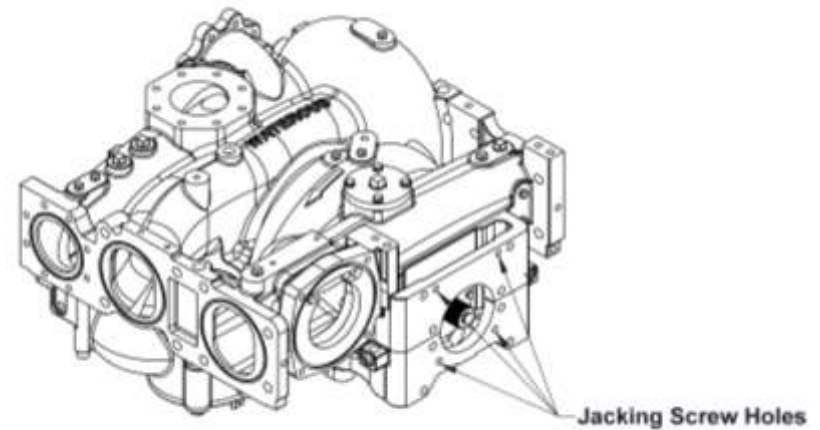

IL2729

## Transmission Removal / Installation

(Transmission Mounted Directly to the Front of the Pump)

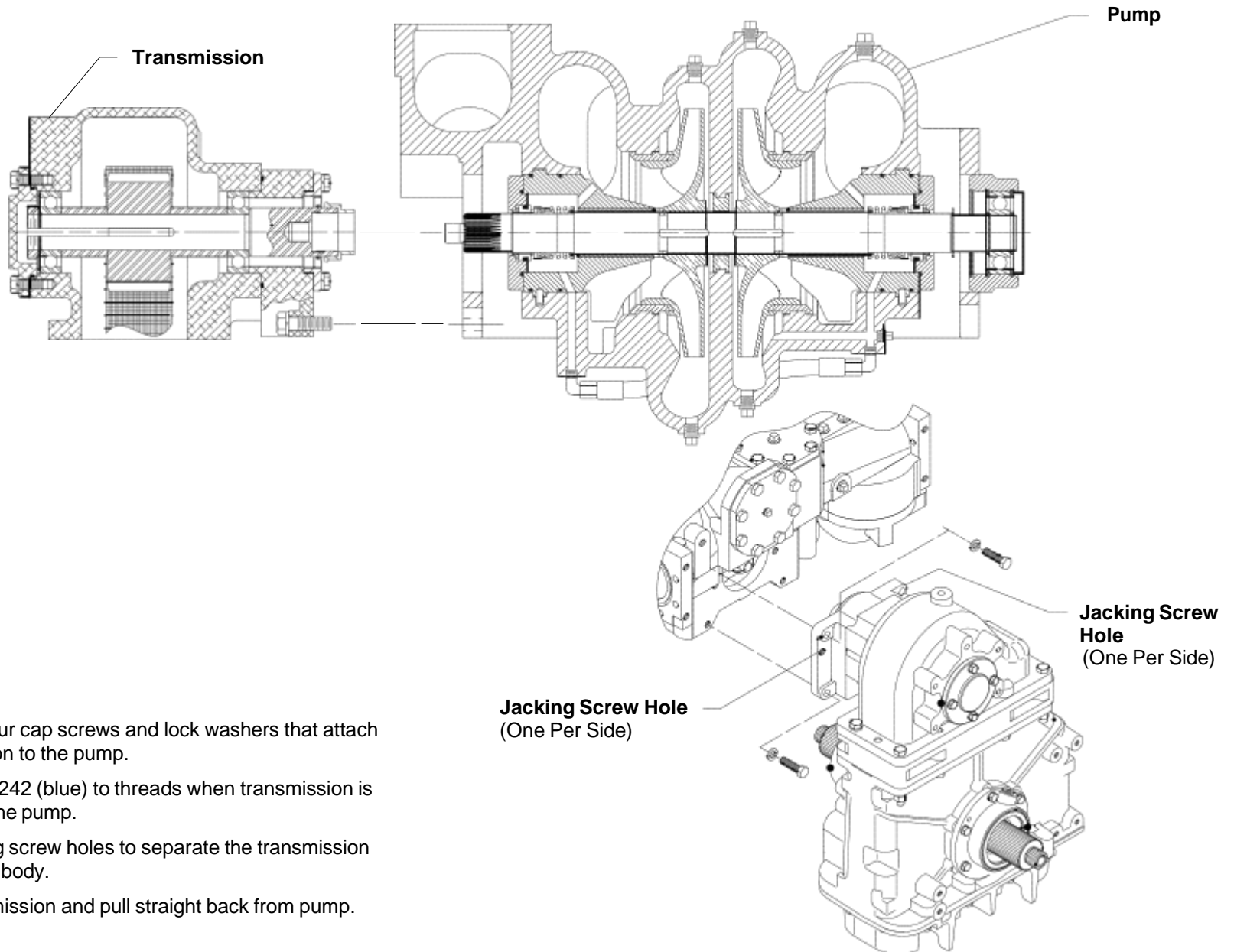

1. Remove the four cap screws and lock washers that attach the transmission to the pump.
2. Apply Loctite #242 (blue) to threads when transmission is reattached to the pump.
3. Use the jacking screw holes to separate the transmission from the pump body.
4. Support transmission and pull straight back from pump.

# Intake Adapter Removal / Installation

1. Remove the hex hd screws that attach the intake adapters to the pump body.
2. Remove the adapters and gaskets.

**NOTE: Removal of intake adapters is only necessary if pump body or adapters need to be replaced.**

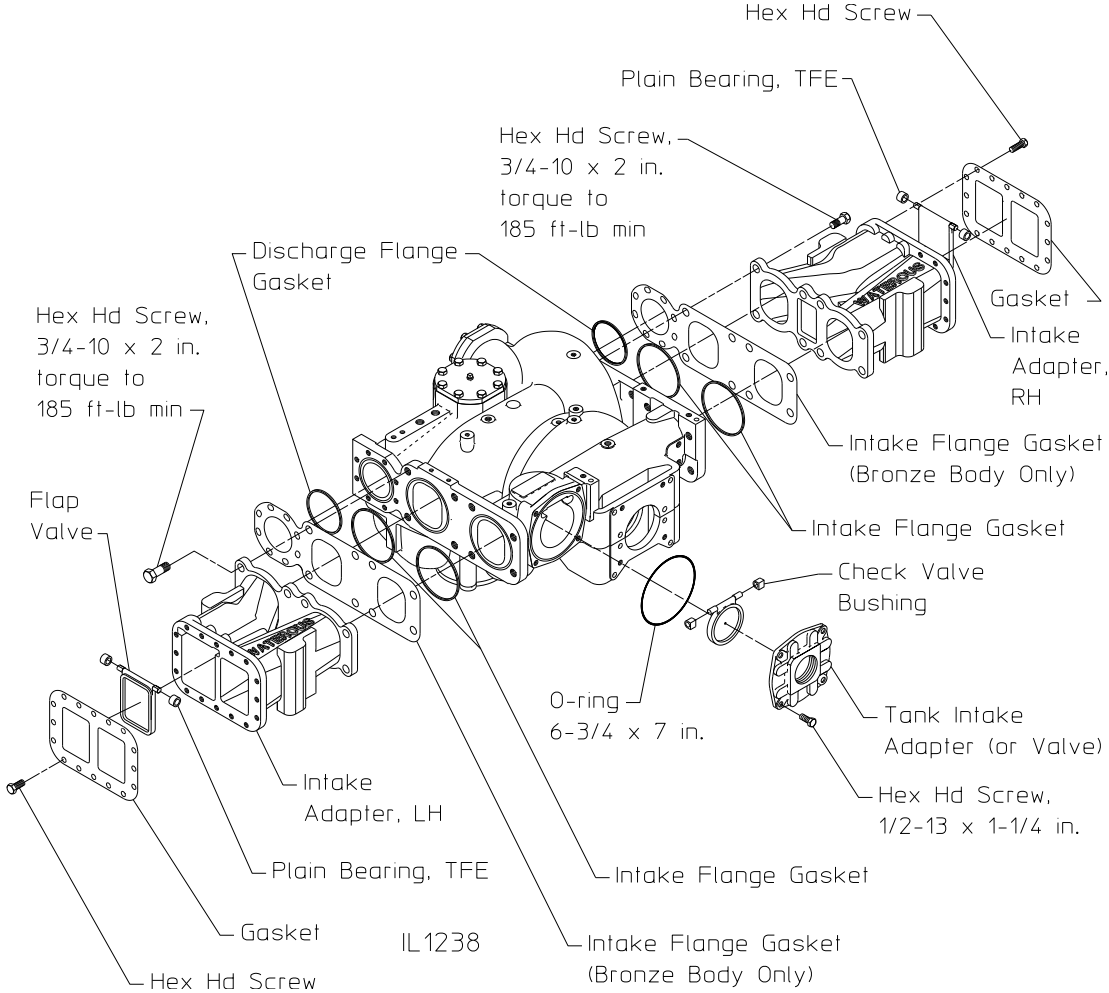

## Removal of Impeller Shaft Assembly

### Transmissions Mounted Directly to the Rear of the Pump and Rear Driven Direct Drive Pumps

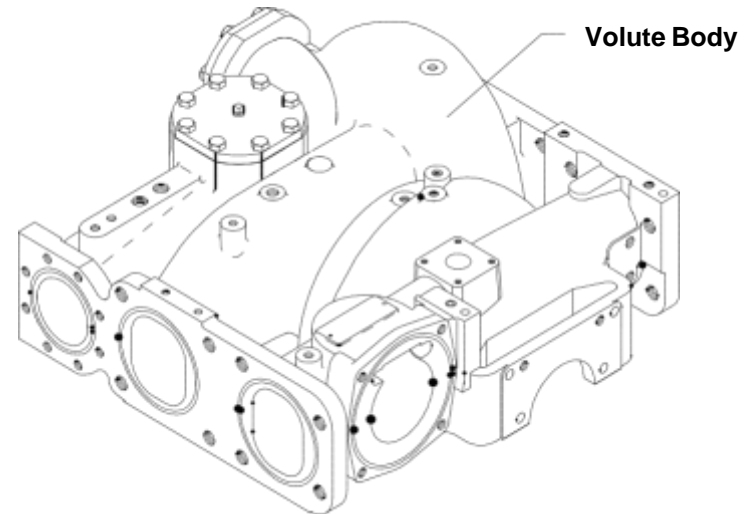
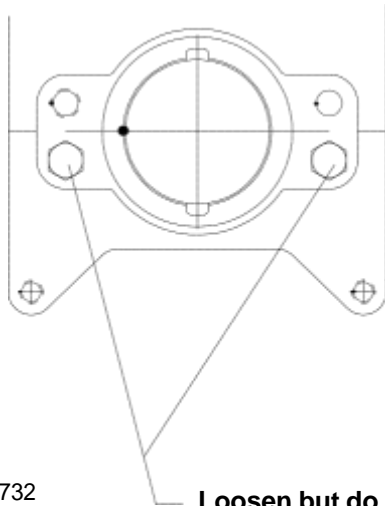

1. Use either threaded rods or a transmission jack to lower the cover from the body.
2. Remove the two screws that attach the bearing housing to the volute body (upper half).
3. Loosen but do not remove the two screws that attach the bearing housing to the volute cover (lower half). The impeller shaft assembly will remain in the volute cover.
4. Remove the screws that attach the volute cover to the volute body and separate the body and cover using the tapped holes.
5. Remove gasket material and O-ring from the two pump halves.

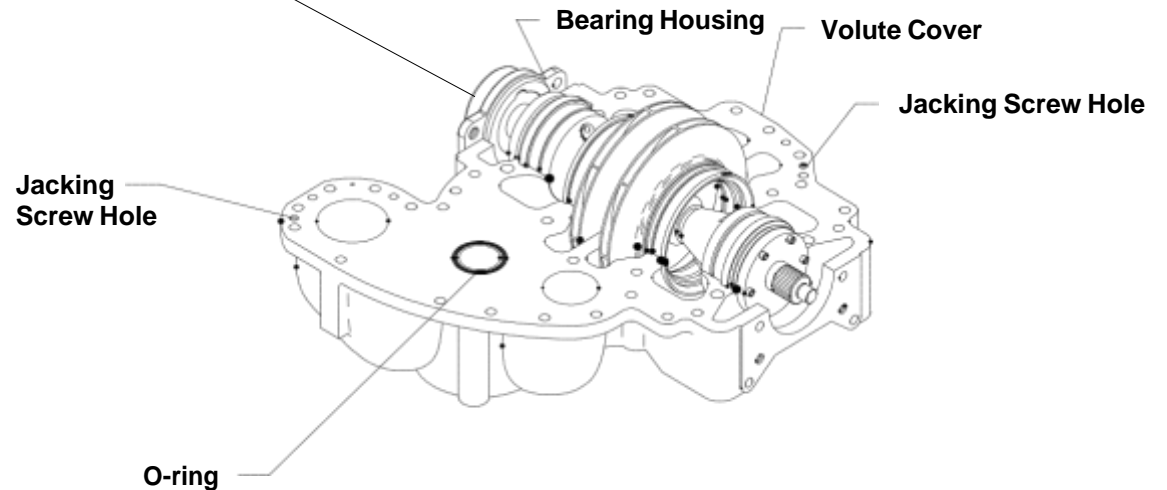

IL1208

## Removal of Impeller Shaft Assembly

### Transmissions Mounted Directly to the Front of the Pump and Rear Driven Direct Drive Pumps

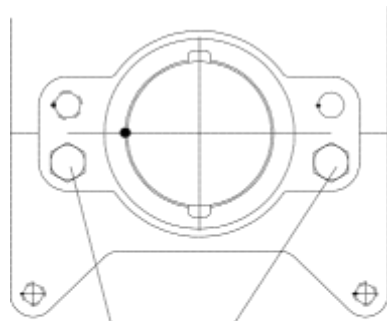

**Bearing Housing**

IL2732

**Loosen but do not remove these screws.**

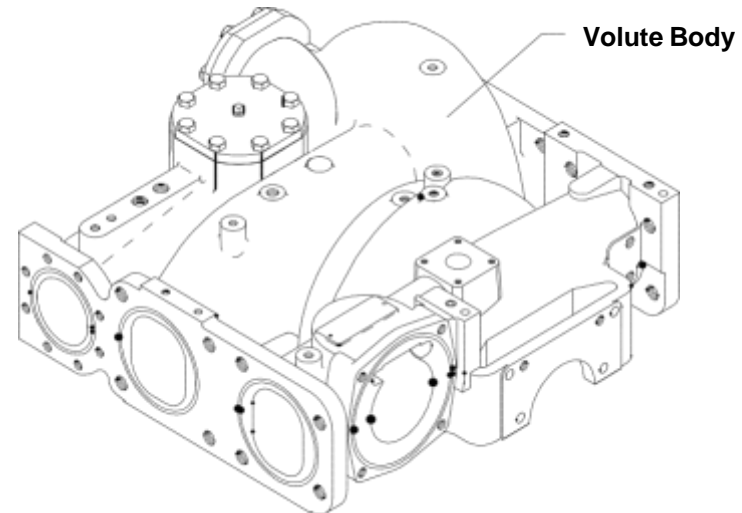

**Volute Body**

1. Use either threaded rods or a transmission jack to lower the cover from the body.
2. Remove the two screws that attach the bearing housing to the volute body (upper half).
3. Loosen but do not remove the two screws that attach the bearing housing to the volute cover (lower half). The impeller shaft assembly will remain in the volute cover.
4. Remove the screws that attach the volute cover to the volute body and separate the body and cover using the tapped holes.
5. Remove gasket material and O-ring from the two pump halves.

**Jacking Screw Hole**

**O-ring**

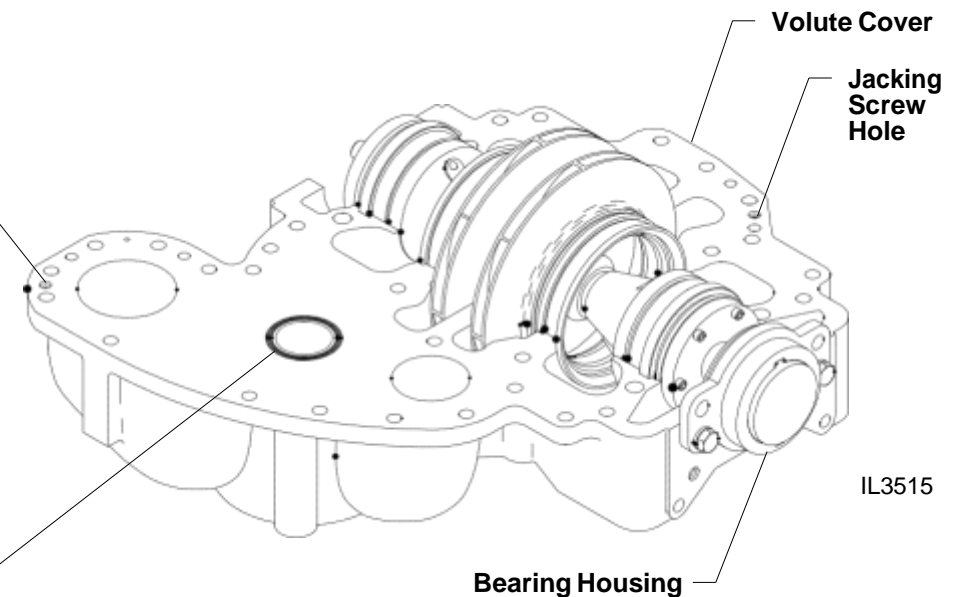

**Volute Cover**

**Jacking Screw Hole**

IL3515

**Bearing Housing**

## Outboard Bearing Removal / Installation - Prior to 4/21/2006

**(Transmission Mounted Pumps with Mechanical Seals or Direct Drive Pumps without Tachometer with Mechanical Seals)**  
 (Reference Pages 16, 17 and 19)

**NOTE: Fill the bearing housing chamber with a medium consistency ball and roller bearing grease until the grease comes out of the lube relief fitting. Check that the seal has not leaked.**

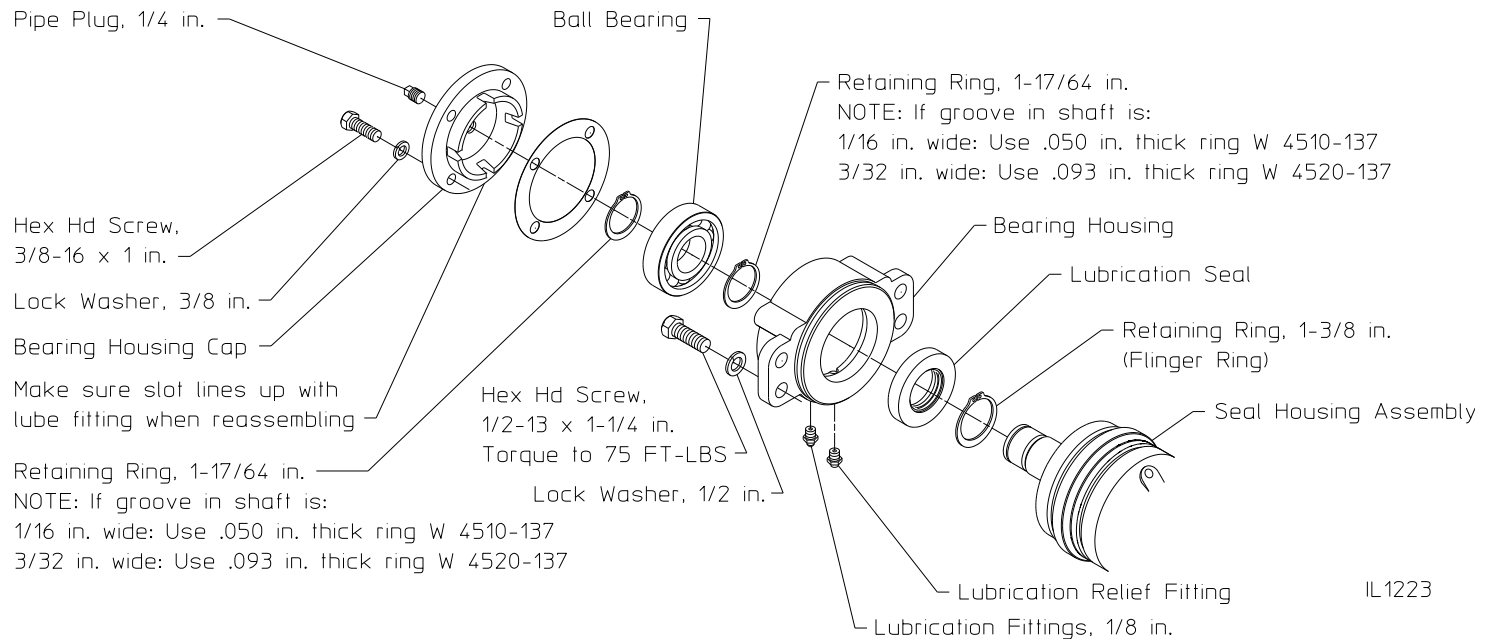

IL1223

**CAUTION**

To prevent seal from pushing out of housing, do not use power grease gun.

# Outboard Bearing Removal / Installation - After 4/21/2006

(Transmission Mounted Pumps with Mechanical Seals)

(Reference Pages 18 and 20)

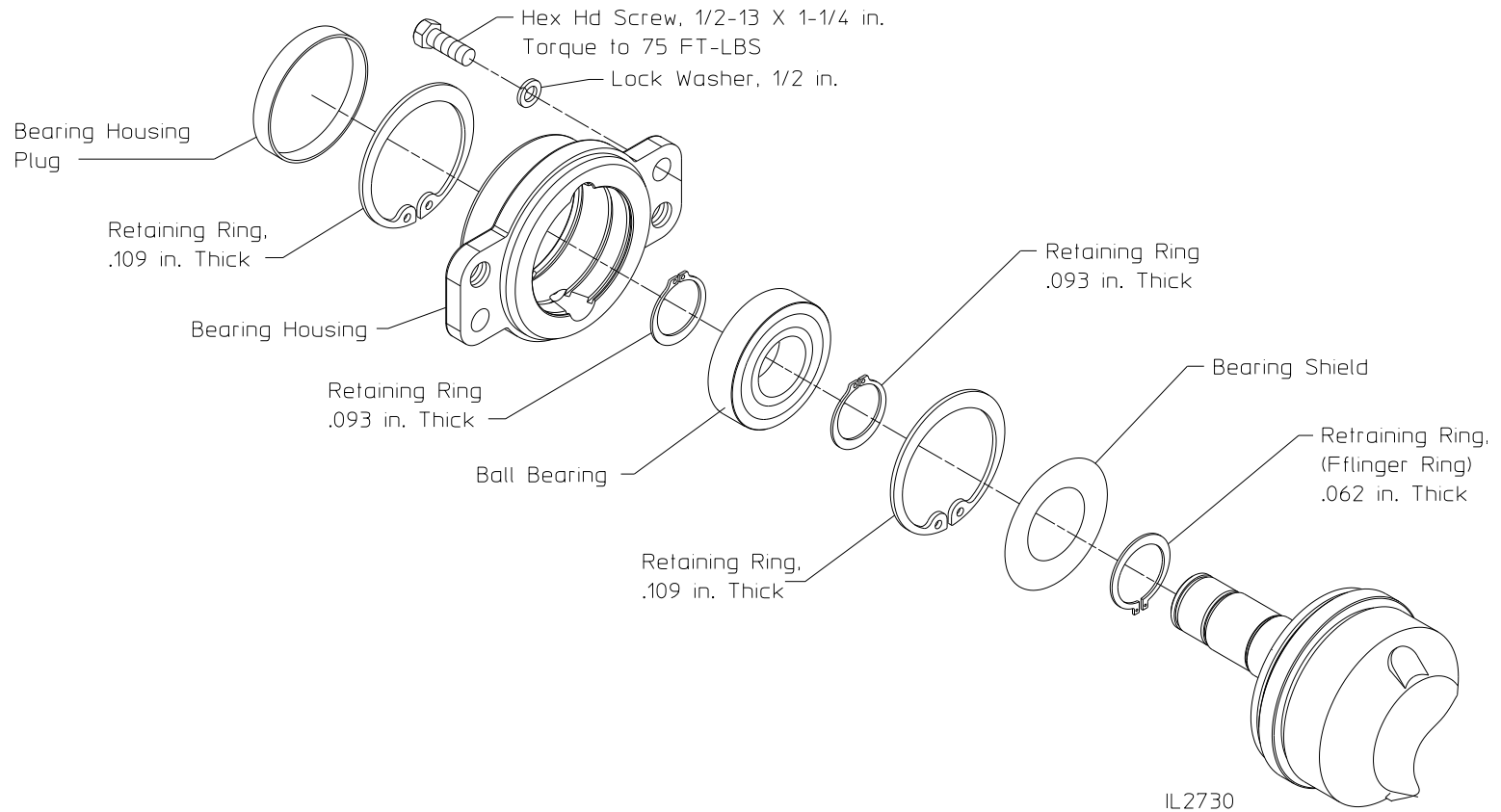

# Outboard Bearing Removal / Installation (Prior to 4/21/06)

(Transmission Mounted Pumps with Packing or Direct Drive Pumps without Tachometer with Packing)  
 (Reference Pages 16, 17 and 19)

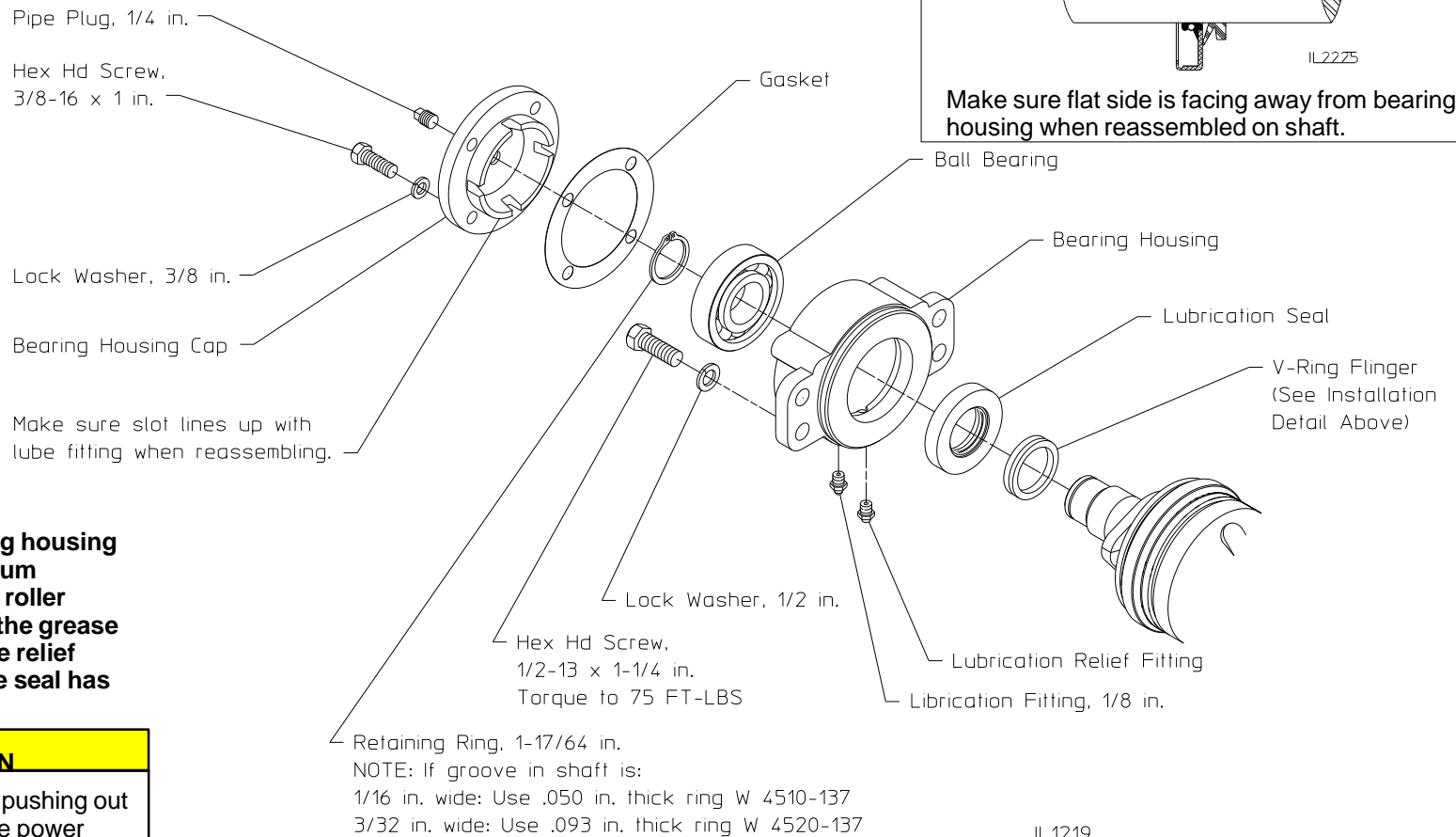
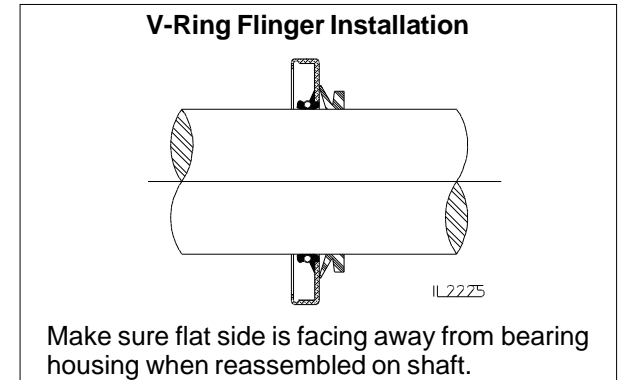

**NOTE: Fill the bearing housing chamber with a medium consistency ball and roller bearing grease until the grease comes out of the lube relief fitting. Check that the seal has not leaked.**

**CAUTION**  
 To prevent seal from pushing out of housing, do not use power grease gun.



# Outboard Bearing Removal / Installation (After 4/21/06)

**(Transmission Mounted Pumps with Packing)**

**(Reference Pages 17 and 18)**

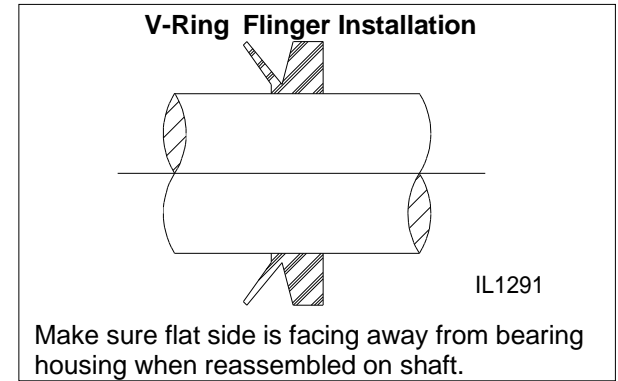
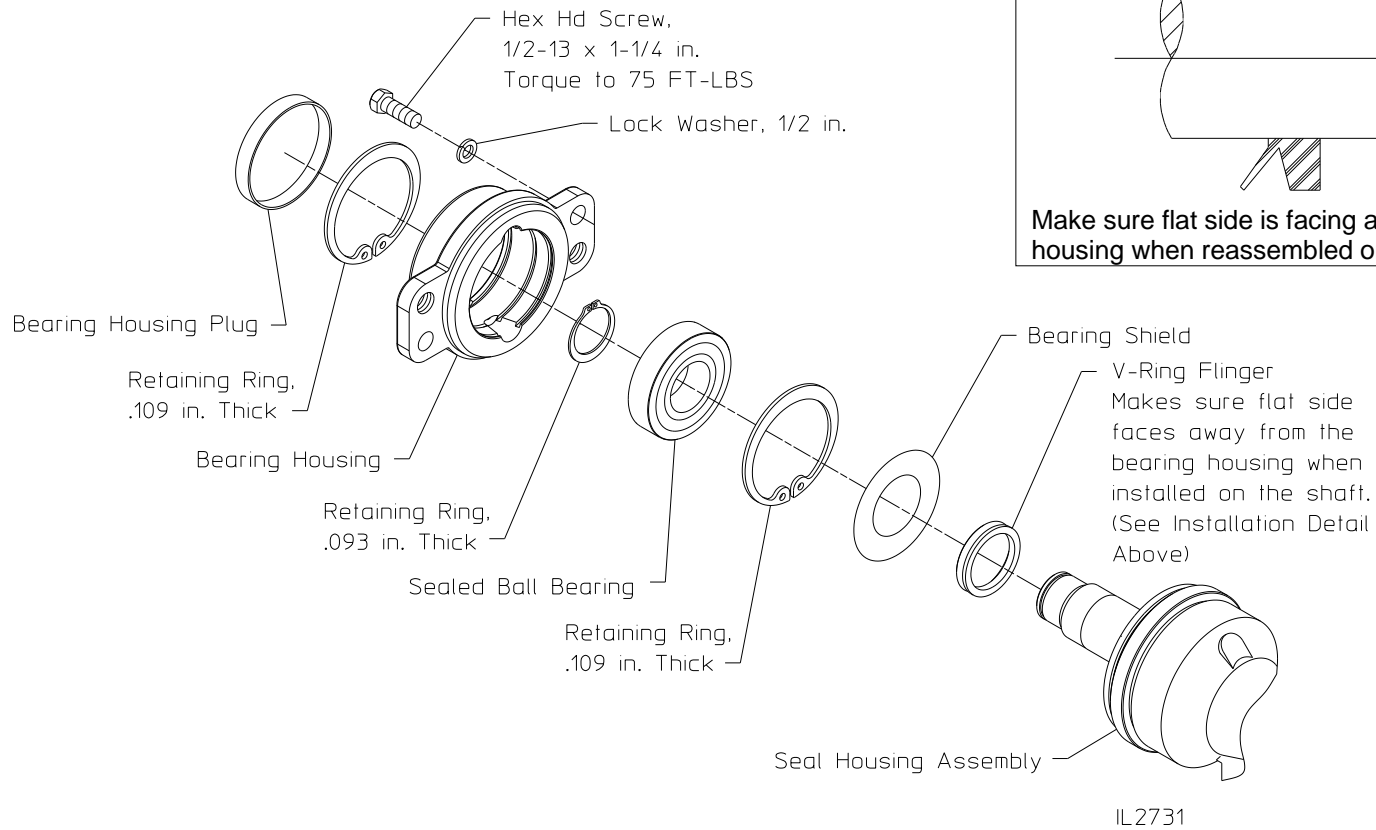

# Outboard Bearing Removal / Installation

(Direct Drive Pumps - Front Drive with Tachometer)

**NOTE: Fill the bearing housing chamber with a medium consistency ball and roller bearing grease until the grease comes out of the lube relief fitting. Check that the seal has not leaked.**

**CAUTION**  
To prevent seal from pushing out of housing, do not use power grease gun.

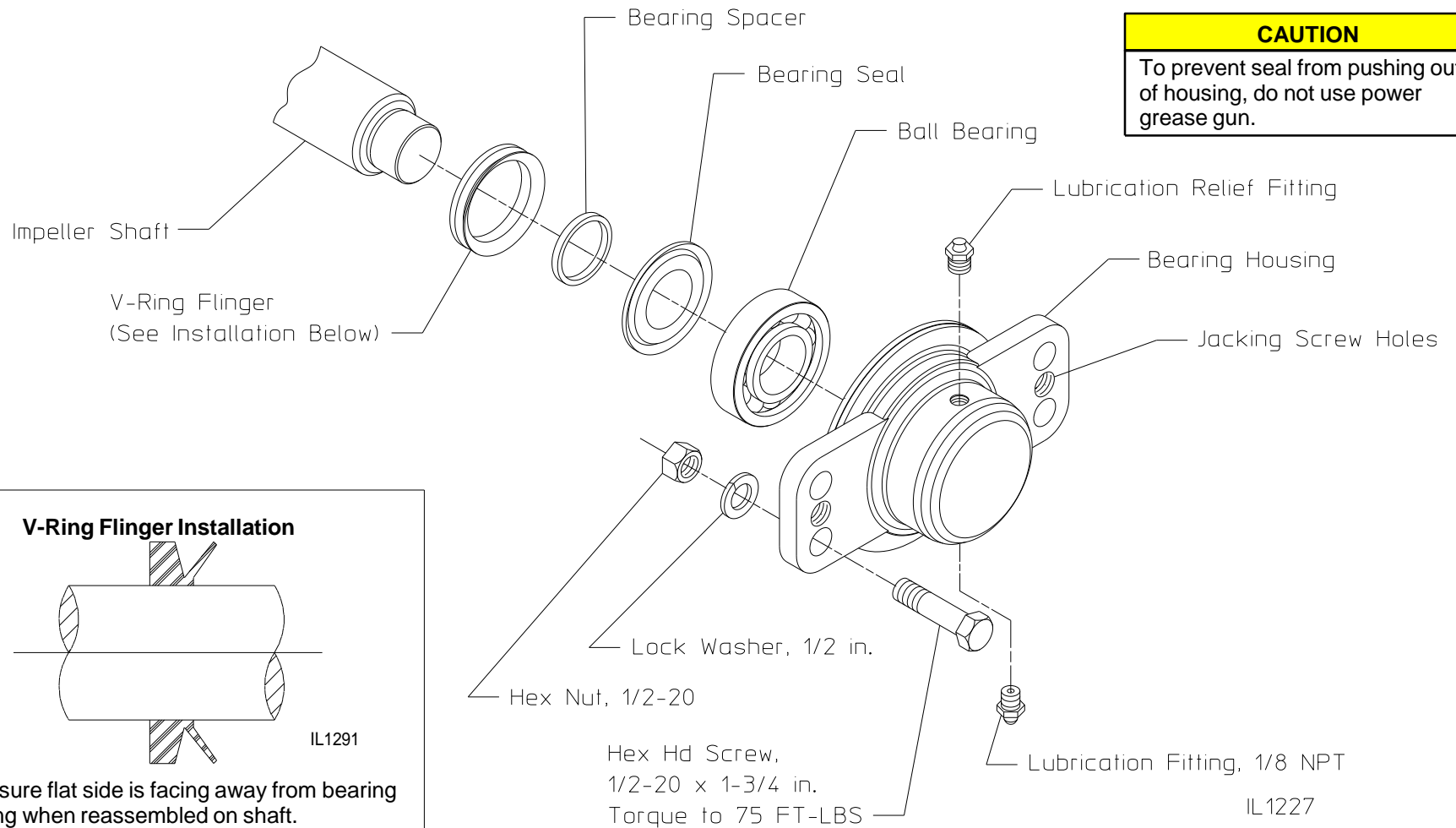

**V-Ring Flinger Installation**

IL1291

Make sure flat side is facing away from bearing housing when reassembled on shaft.

## Outboard Bearing Removal (Prior to 4/21/2006)

1. Remove the oil pump (if so equipped) and the bearing housing cap.
2. Remove the bearing outer retaining ring from the impeller shaft.
3. Remove the (4) hex hd screws attaching the bearing housing to the pump body.
4. Install hub puller bar. (Use bearing removal tool if removing outboard bearing on units equipped with lube pump - See Page 17).
5. Tighten hub puller screw, causing the bearing housing to pull the bearing off of the end of the impeller shaft.
6. Remove inner bearing retaining ring from impeller shaft. (Note: Inner retaining ring not used on pumps with packing).
7. Remove and discard lubrication seal. Remove bearing from bearing housing. Completely clean bearing housing of grease and replace bearing.
8. Remove inner bearing retaining ring from impeller shaft. (Note: Inner retaining ring not used on pumps with packing).

### CAUTION

Make sure center of hub puller screw does not damage the threaded center of shaft. Apply grease to shaft center or bearing removal tool before installing hub puller.

## Outboard Bearing Removal (without Lube pump, Prior to 4/21/2006)

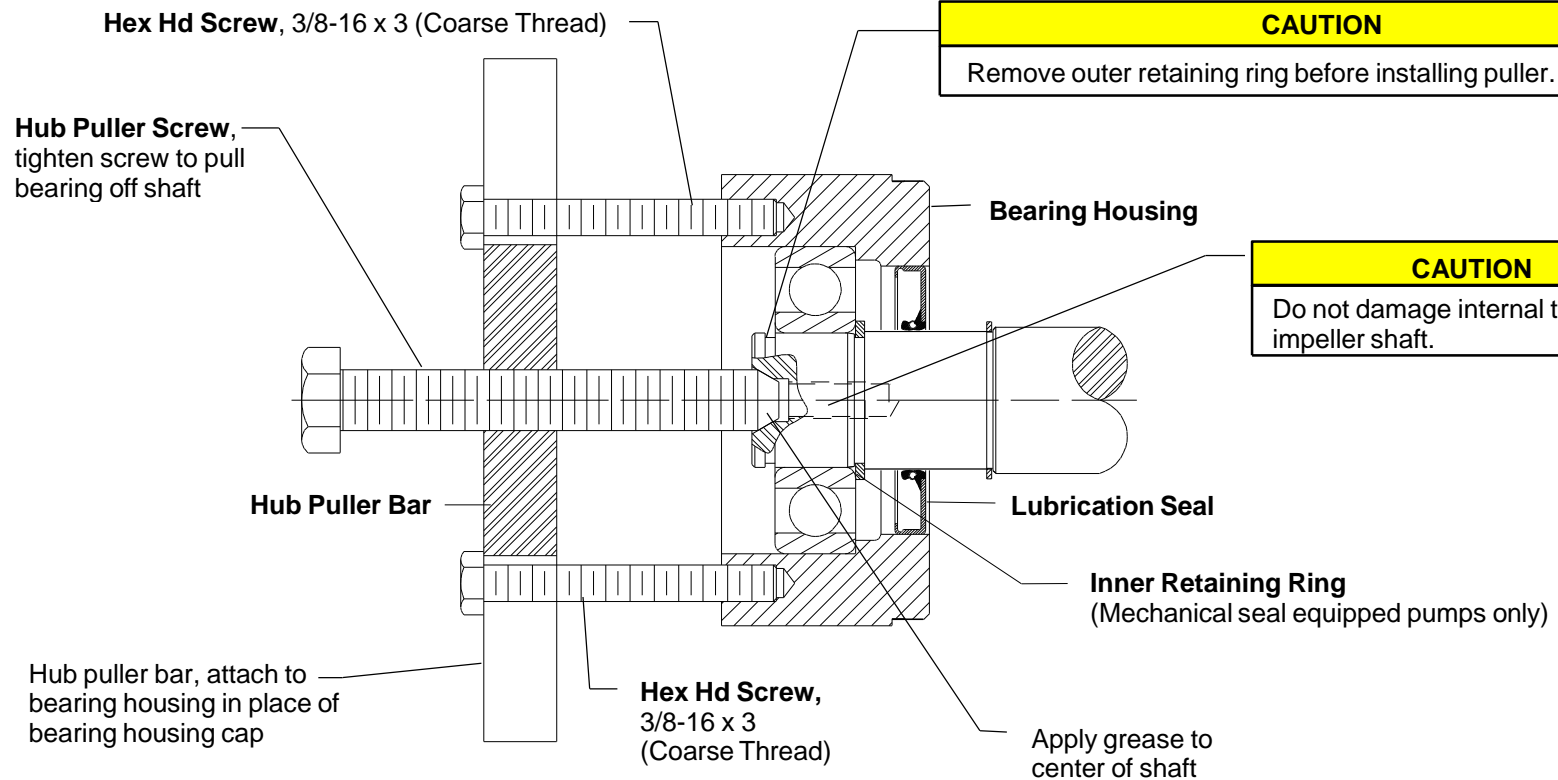

IL2026

# Outboard Bearing Removal with Lube Pump (Prior to 4/21/2006)

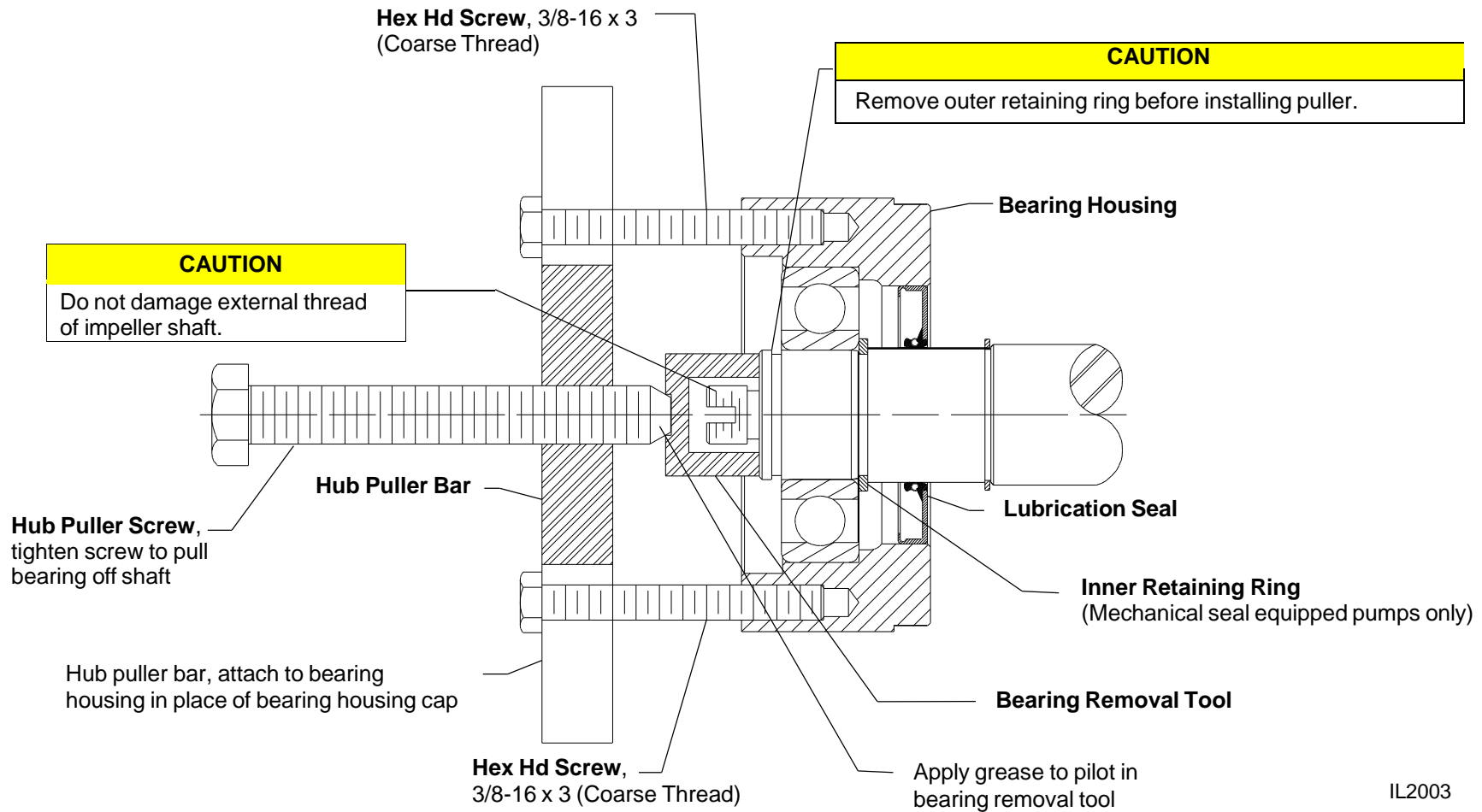

## Outboard Bearing Removal (After 4/21/2006)

1. Remove plug from bearing housing.
2. Remove the bearing outer retaining rings from the impeller shaft.
3. Remove (4) hex hd screws attaching the bearing housing to the pump body.
4. Install hub puller bar. (Use bearing removal tool if removing outboard bearing on units equipped with lube pump - See Page 17).
5. Tighten hub puller screw, causing the bearing housing to pull the bearing off of the end of the impeller shaft.
6. Remove inner bearing retaining rings from impeller shaft and bearing housing.
7. Remove bearing from bearing housing.

### CAUTION

Make sure center of hub puller screw does not damage threaded center of shaft. Apply grease to shaft center or bearing removal tool before installing hub puller.

## Outboard Bearing Removal (After to 4/21/2006)

### CAUTION

Remove outer retaining rings before installing puller.

Hex Hd Screw, 5/8-11 x 3 (Coarse Thread)

Hub Puller Screw,  
tighten screw to pull  
bearing off shaft

Bearing Housing

Inner Retaining Rings

Note: This ring is used on pumps with Mechanical seals only, not used on pumps with packing, these shafts have a machined shoulder.

### CAUTION

Do not damage internal thread of impeller shaft.

Hub Puller Bar

Shield

Apply grease to  
center of shaft

Hub puller bar, attach to bearing housing in place of bearing housing cap

Hex Hd Screw,  
5/8-11 x 3 (Coarse Thread)

IL2717

## Outboard Bearing Installation (Prior to 4/21/2006)

1. Packed Pumps: Install v-ring flinger on impeller shaft. Mechanical Seal Pumps: Install (flinger) retaining ring on impeller shaft.
2. Install new lubrication seal in bearing housing and reinstall bearing housing on pump.
3. Install inner bearing retaining ring. (Note: Inner retaining ring not used on pumps with packing). Ensure correct retaining ring is used.  
**NOTE: Retaining rings changed 7/1/95. If groove width is 1/16" wide use W 4510-137, if 3/32" wide use W 4520-137.**
4. Apply grease to the bearing journal of the impeller shaft to aid in assembly and slide the bearing into the bearing housing until it contacts the impeller shaft.
5. Screw hex nut onto hex hd screw and slide flat washer, thrust washer and bearing installation tool housing onto screw.
  - a. For units equipped without an oil pump attach assembled tool to the impeller shaft by threading hex hd screw completely into the internal thread of the impeller shaft.
  - b. For units equipped with and oil pump (Figure 5), thread bearing installation tool onto the external thread of the impeller shaft. Attach assembled tool to the bearing installation tool by threading hex hd screw completely into the internal thread of the bearing installation tool.
6. Push the bearing onto the impeller shaft until it seats against the inner retaining ring (or shaft shoulder) by tightening the hex nut against the bearing installation tool housing. It may be necessary to hold the hex hd screw to prevent it from turning with the hex nut.
7. Remove the tool and install the bearing outer retaining ring. Ensure correct retaining ring is used.
8. Install the bearing housing cap and gasket. Make sure the slot on the cap lines up with the grease fitting. Install oil pump and gasket (if so equipped). Make sure the drive tang on the oil pump lines with the slot in the impeller shaft.
9. Fill the bearing housing chamber with a medium consistency ball and roller bearing grease (such as Amoco Super Permalube) until the grease comes out of the lube relief fitting. Check that lubrication seal has not leaked.

### Outboard Bearing Installation (without Lube Pump) Prior to 4/21/2006

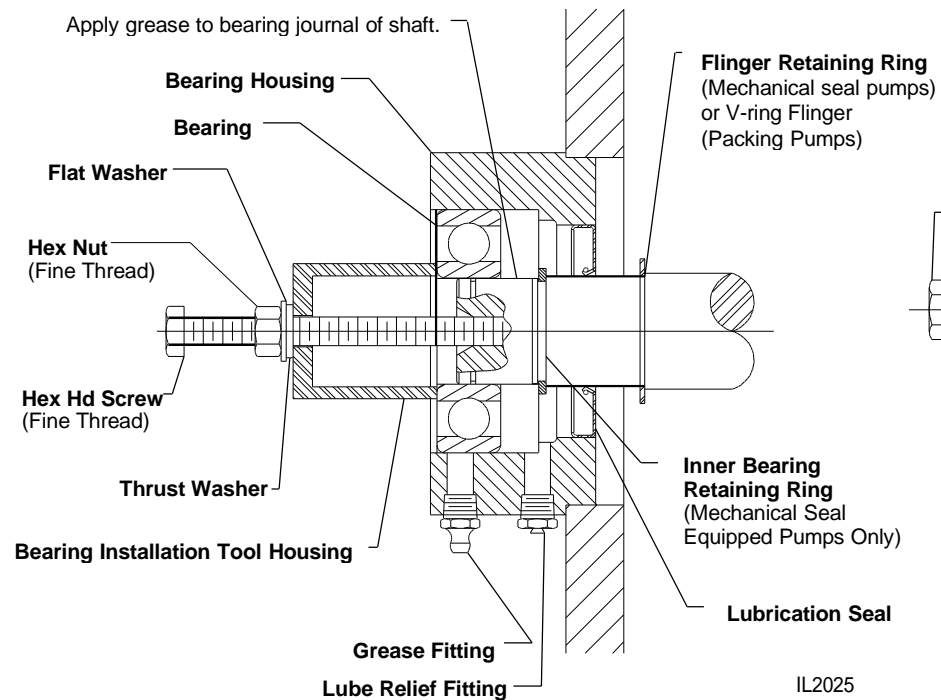

### Outboard Bearing Installation (with Lube Pump) Prior to 4/21/2006

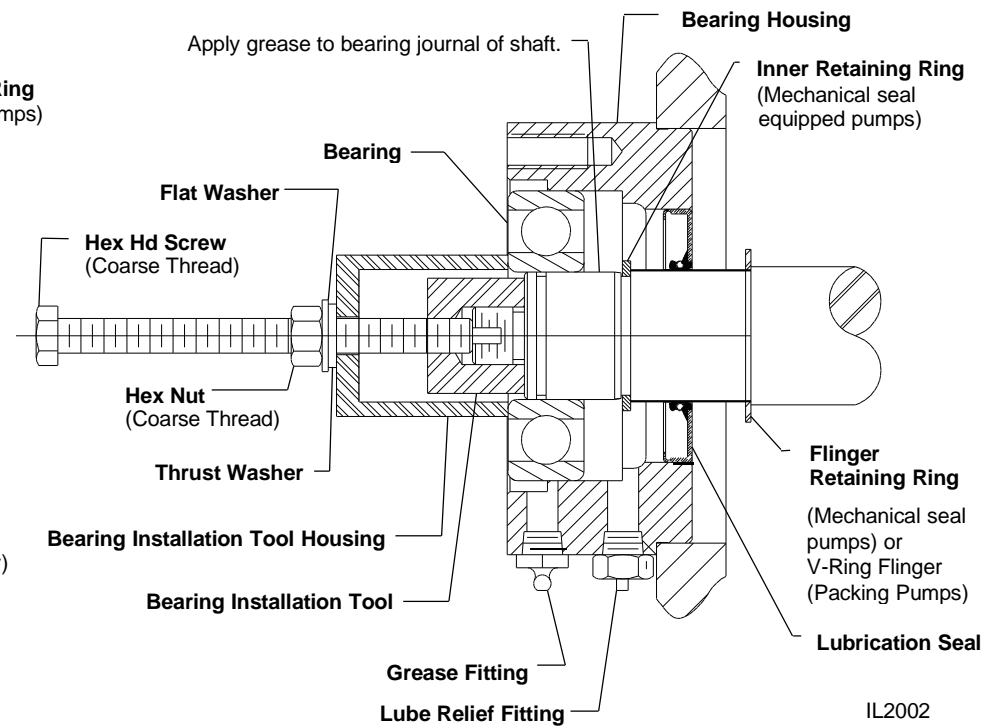

## Outboard Bearing Installation (After 4/21/2006)

1. Packed Pumps: Install v-ring flinger on impeller shaft. Mechanical Seal Pumps: Install (flinger) retaining ring on impeller shaft.
2. Install new shield seal in bearing housing and reinstall bearing housing on pump.
3. Install inner bearing retaining rings. (**Note: Inner retaining ring on shaft is not used on pumps with packing**).
4. Apply grease to the bearing journal of the impeller shaft to aid in assembly and slide the bearing into the bearing housing until it contacts the impeller shaft.
5. Screw hex nut onto hex hd screw and slide flat washer, thrust washer and bearing installation tool housing onto screw.
6. Push the bearing onto the impeller shaft until it seats against the inner retaining ring (or shaft shoulder) by tightening the hex nut against the bearing installation tool housing. It may be necessary to hold the hex hd screw to prevent it from turning with the hex nut.
7. Remove the tool and install the bearing outer retaining rings.
8. Install plug in outside of bearing housing.
9. Note that bearing is sealed and does not require external lubrication.

### Outboard Bearing Installation (after 4/21/2006)

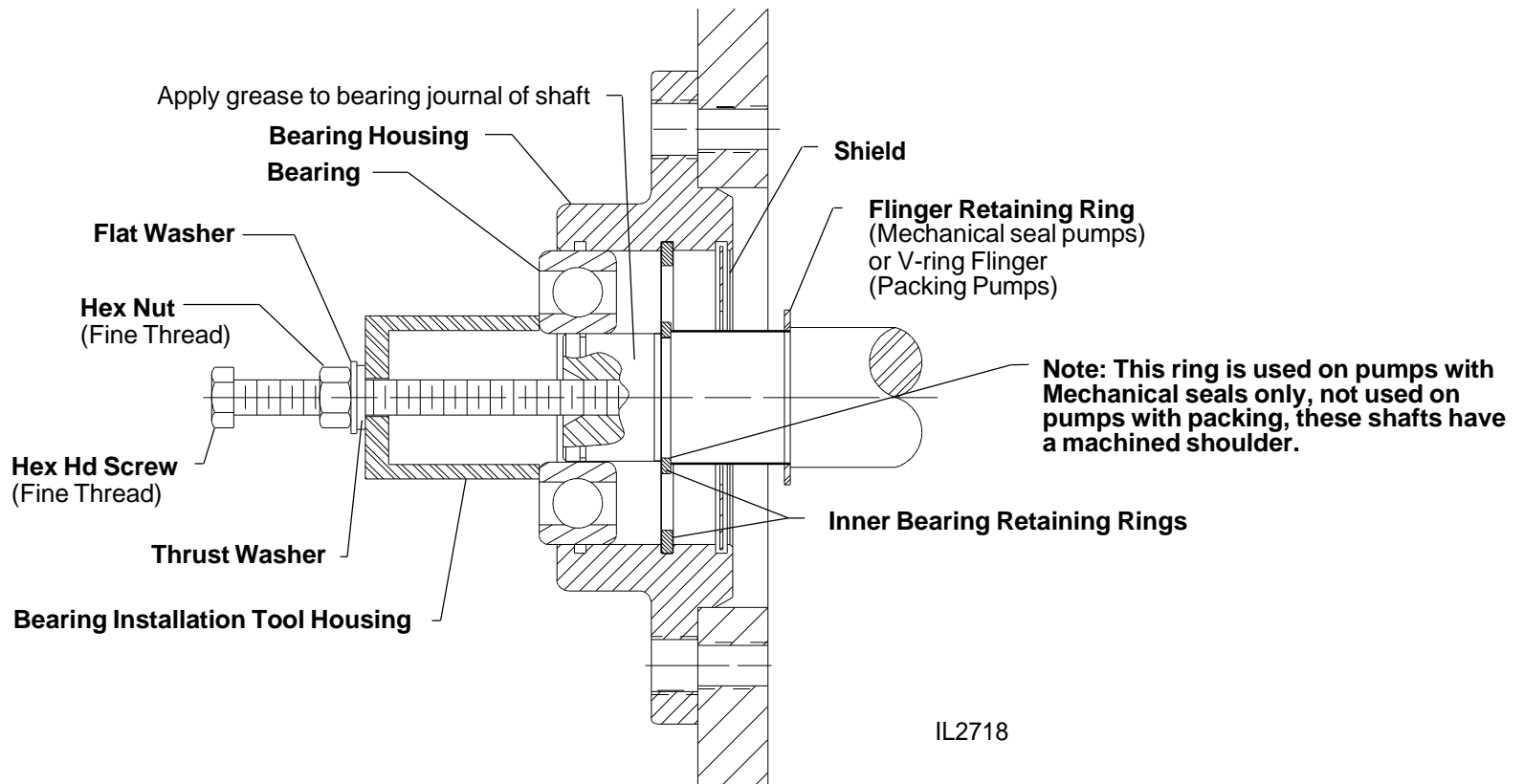

# End Yoke Removal/Installation on Drive End

## (Front Drive with Tachometer)

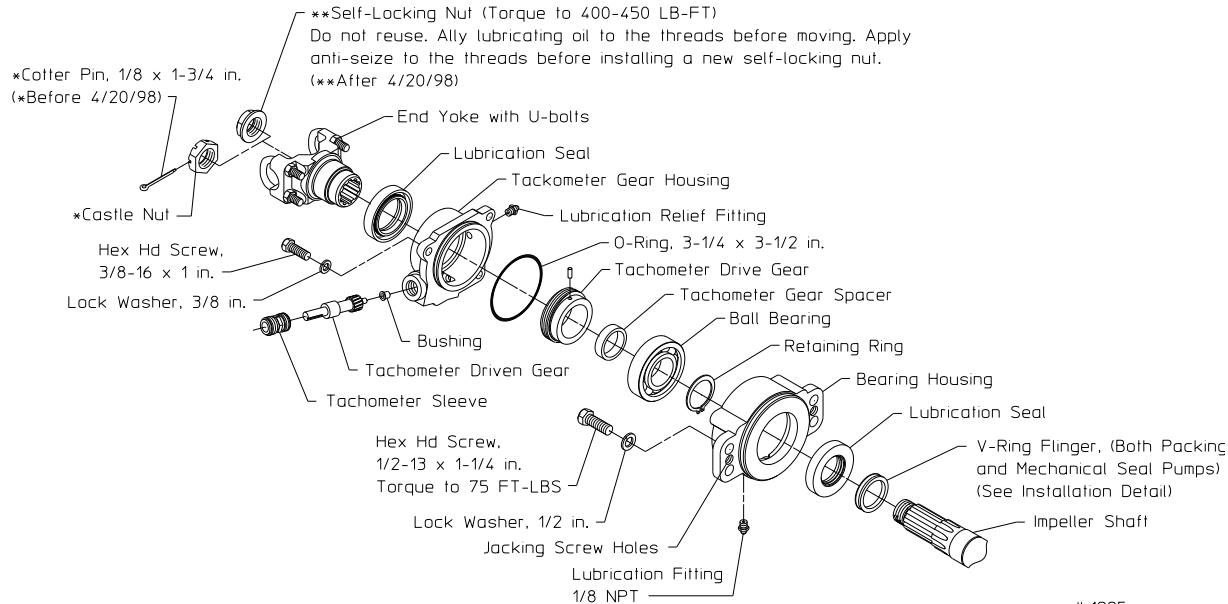

**NOTE: Fill the bearing housing chamber with a medium consistency ball and roller bearing grease until the grease comes out of the lube relief fitting. Check that the seal has not leaked.**

**CAUTION**

To prevent seal from pushing out of housing, do not use power grease gun.

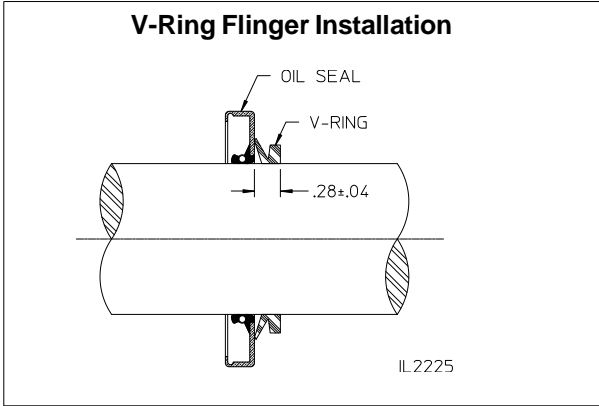

Make sure flat side is facing away from bearing housing when reassembled on shaft.



# End Yoke Removal / Installation on Drive End

(Front or Rear Drive without Tachometer)

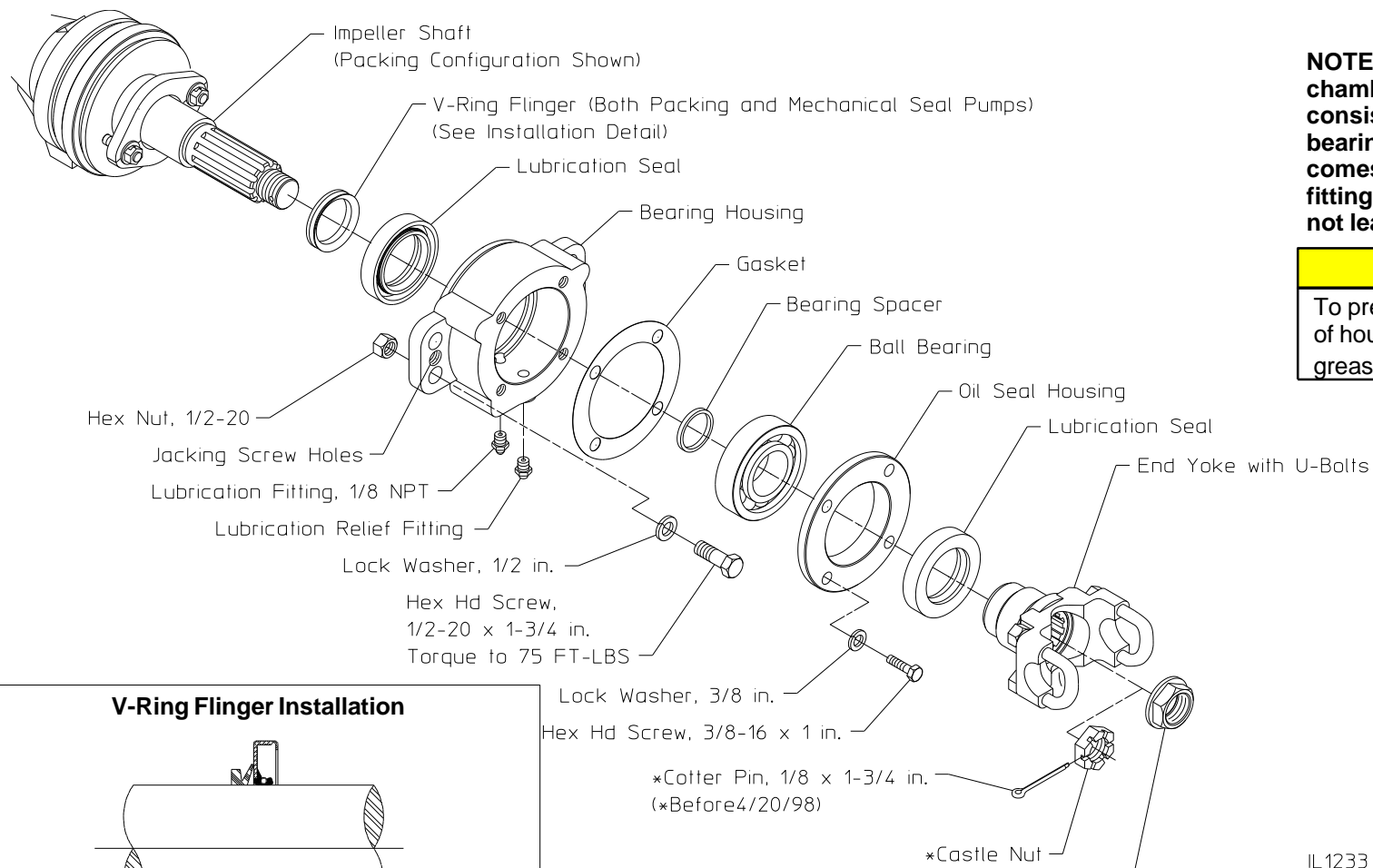

**NOTE: Fill the bearing housing chamber with a medium consistency ball and roller bearing grease until the grease comes out of the lube relief fitting. Check that the seal has not leaked.**

**CAUTION**  
To prevent seal from pushing out of housing, do not use power grease gun.

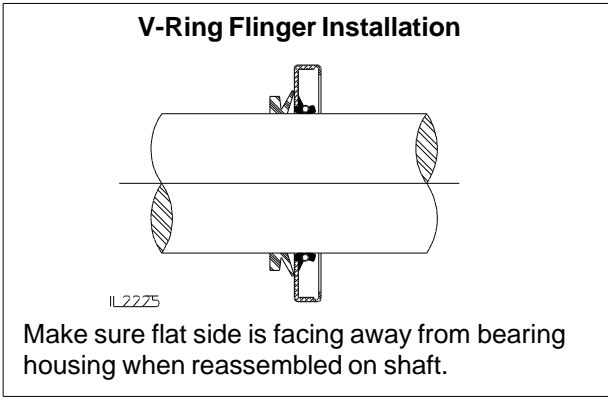

\*\*Self Locking Nut (Torque to 400-450 LB-FT)  
Do not reuse. Apply lubricating oil to the threads before moving. Apply anti-sieze to the threads before installing a new self locking nut. (\*\*After 4/20/98)

IL1233

# Seal Housing Removal / Installation

(Pumps with Mechanical Seals)

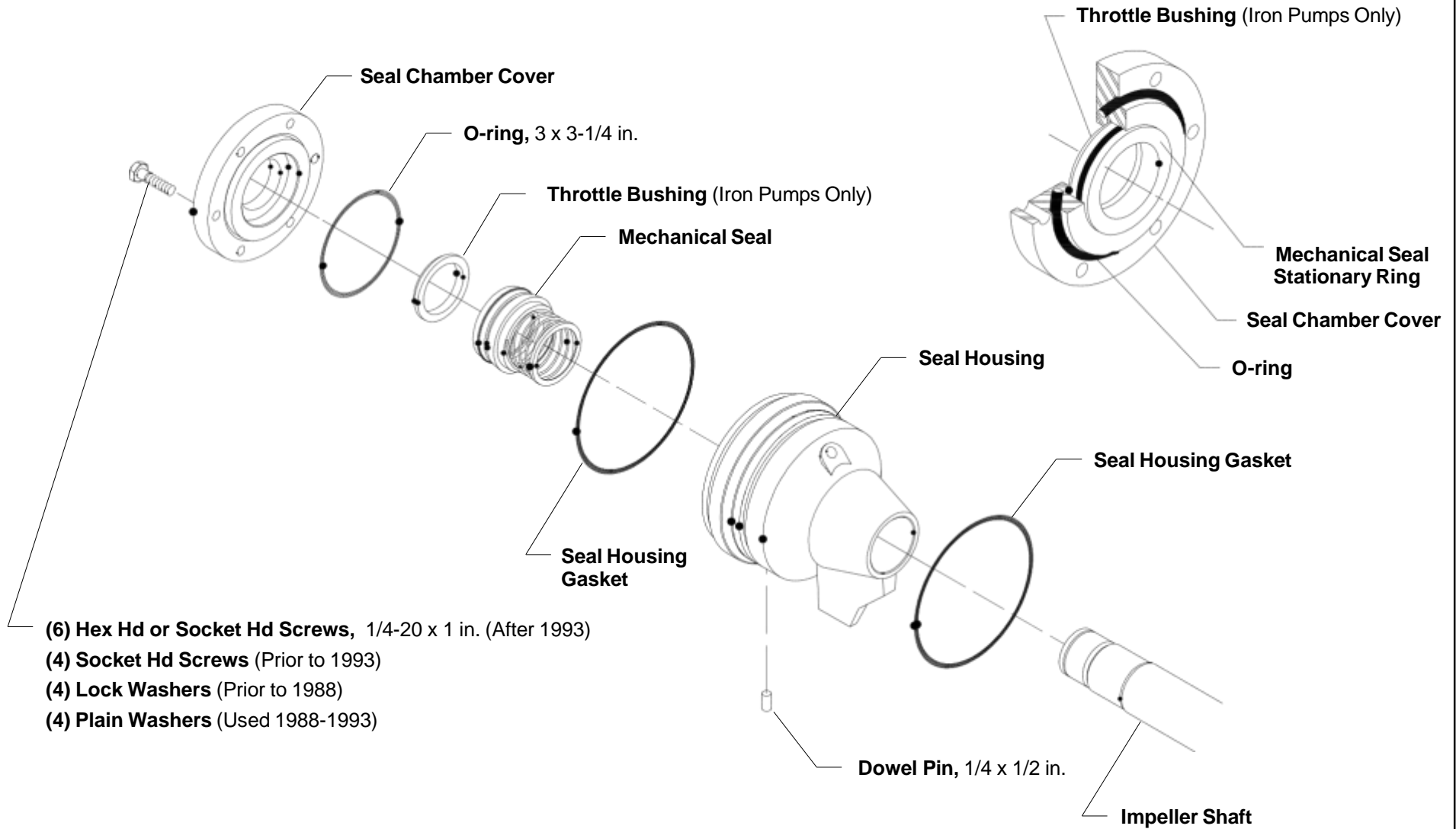

IL 1224/1283

# Seal Housing Removal / Installation

(Pumps with Packing)

**NOTE:** Remove gland before removing seal housing from impeller shaft.

**NOTE:** Install lantern ring, packing, gland, studs, washers and nuts in seal housing before installing on shaft (See Page 40).

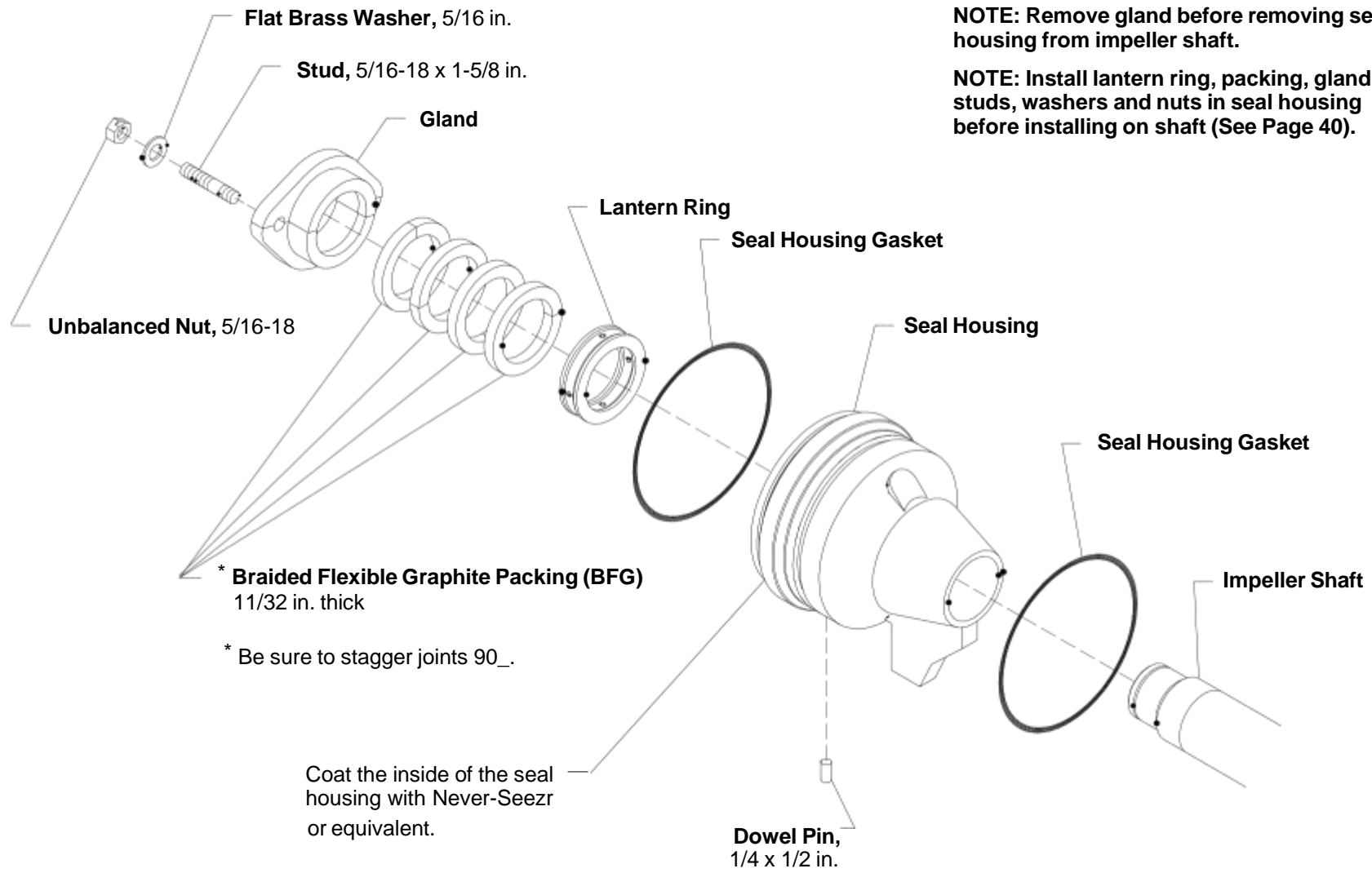

IL1220

# Impeller Removal

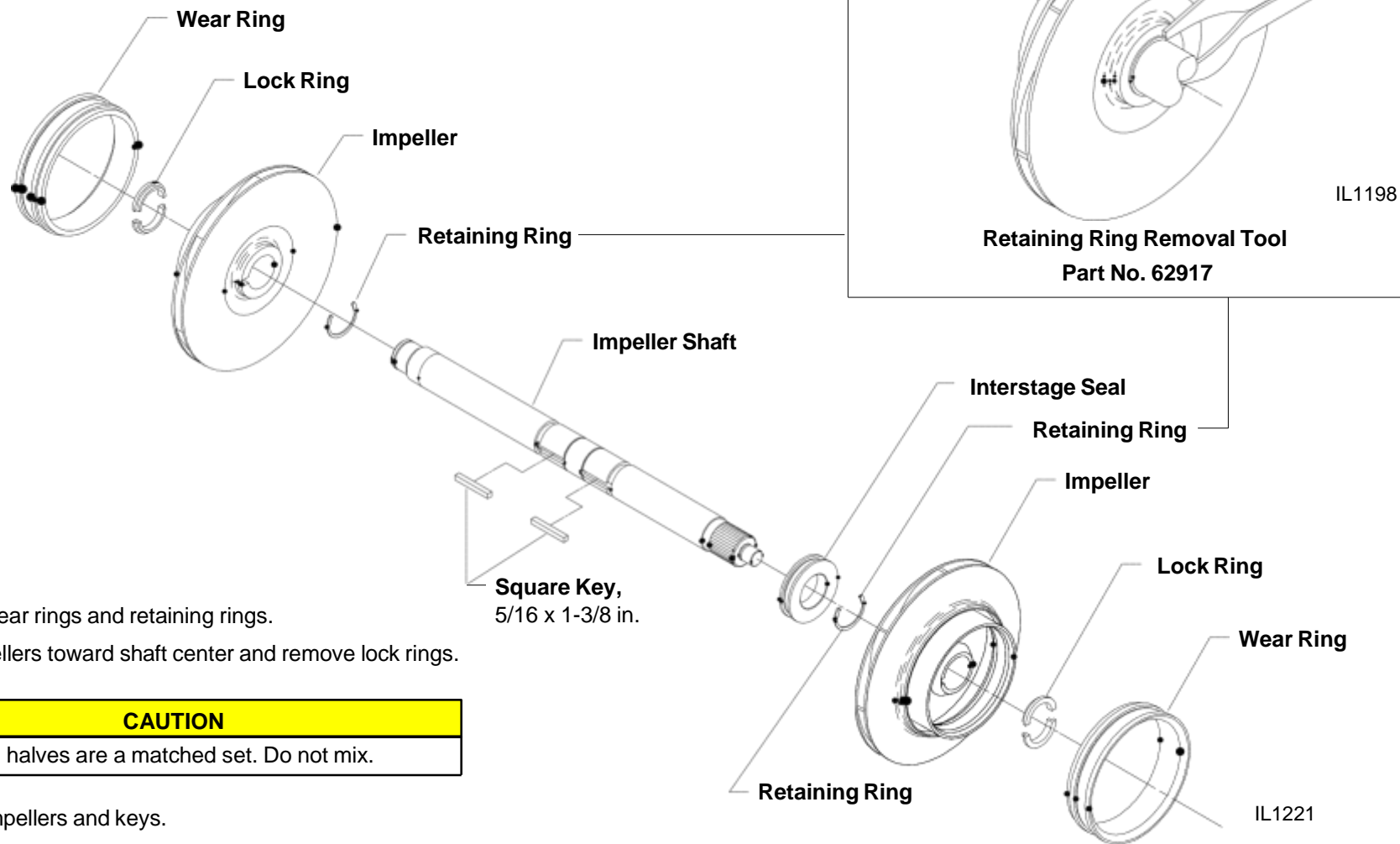

1. Remove wear rings and retaining rings.
2. Press impellers toward shaft center and remove lock rings.

**CAUTION**

Lock ring halves are a matched set. Do not mix.

3. Remove impellers and keys.
4. Remove interstage seal.

# Interstage Seal and Seal Housing and Cooling Line Check

## (Mechanical Seal)

These parts seldom need replacing if handled properly during disassembly and reassembly.

**Interstage Seal** - If the total clearance between the interstage seal and the impeller shaft is greater than 0.015 in., the interstage seal should be replaced.

**Seal Housing** - If the total clearance between the seal housing and the impeller shaft is greater than 0.020 in., the seal housing should be replaced. Check both seal housings.

**Cooling Lines** - Ensure that cooling lines are not plugged and are free of debris. A flexible tool must be used in cleaning out cooling lines due to offset in seal housing hole.

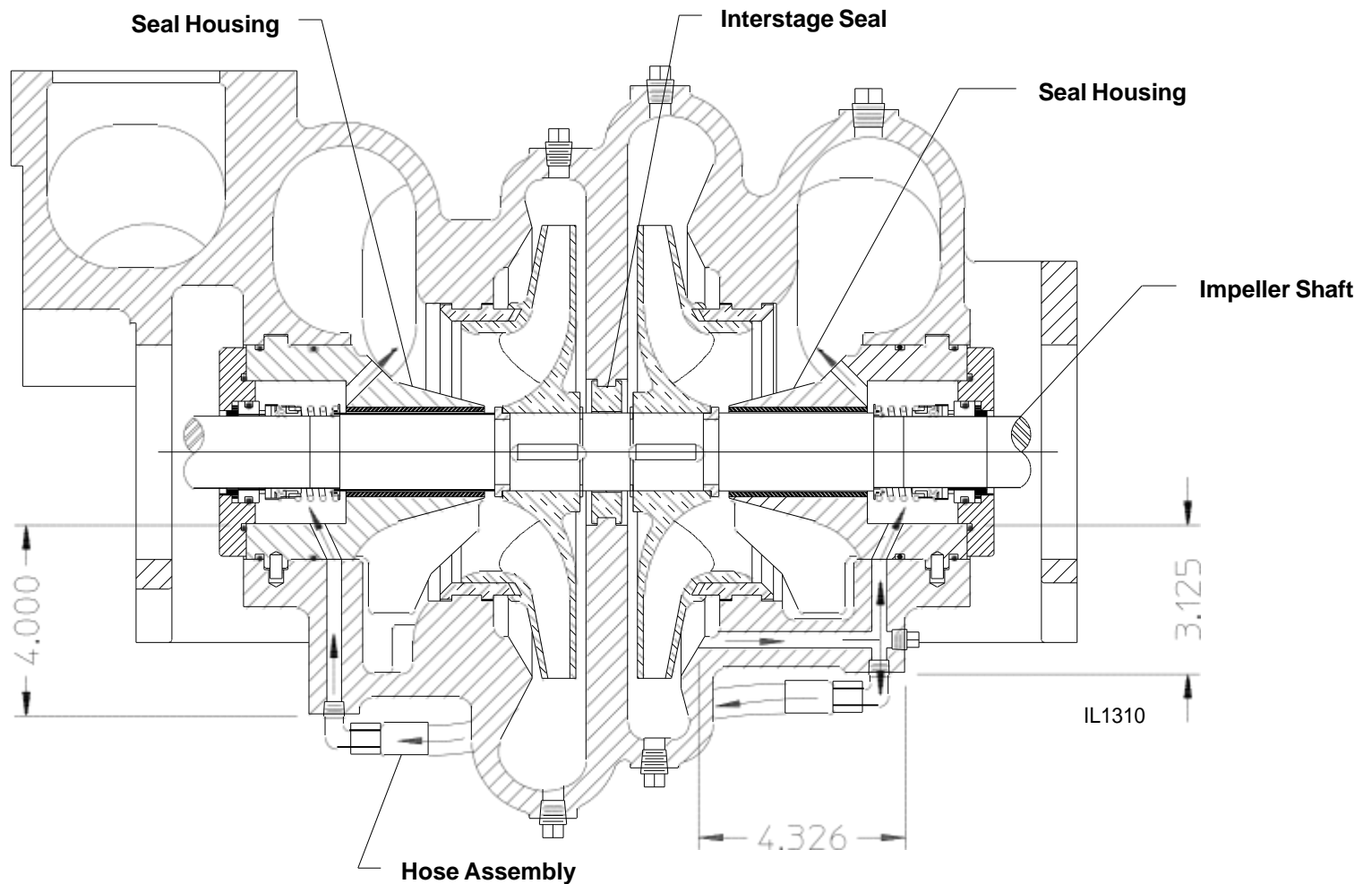

# Interstage Seal and Seal Housing and Cooling Line Check

## (Packing)

These parts seldom need replacing if handled properly during disassembly and reassembly.

**Interstage Seal** - If the total clearance between the interstage seal and the impeller shaft is greater than 0.015 in., the interstage seal should be replaced.

**Seal Housing** - If the total clearance between the seal housing and the impeller shaft is greater than 0.020 in., the seal housing should be replaced. Check both seal housings.

**Cooling Lines** - Ensure that cooling lines are not plugged and are free of debris.

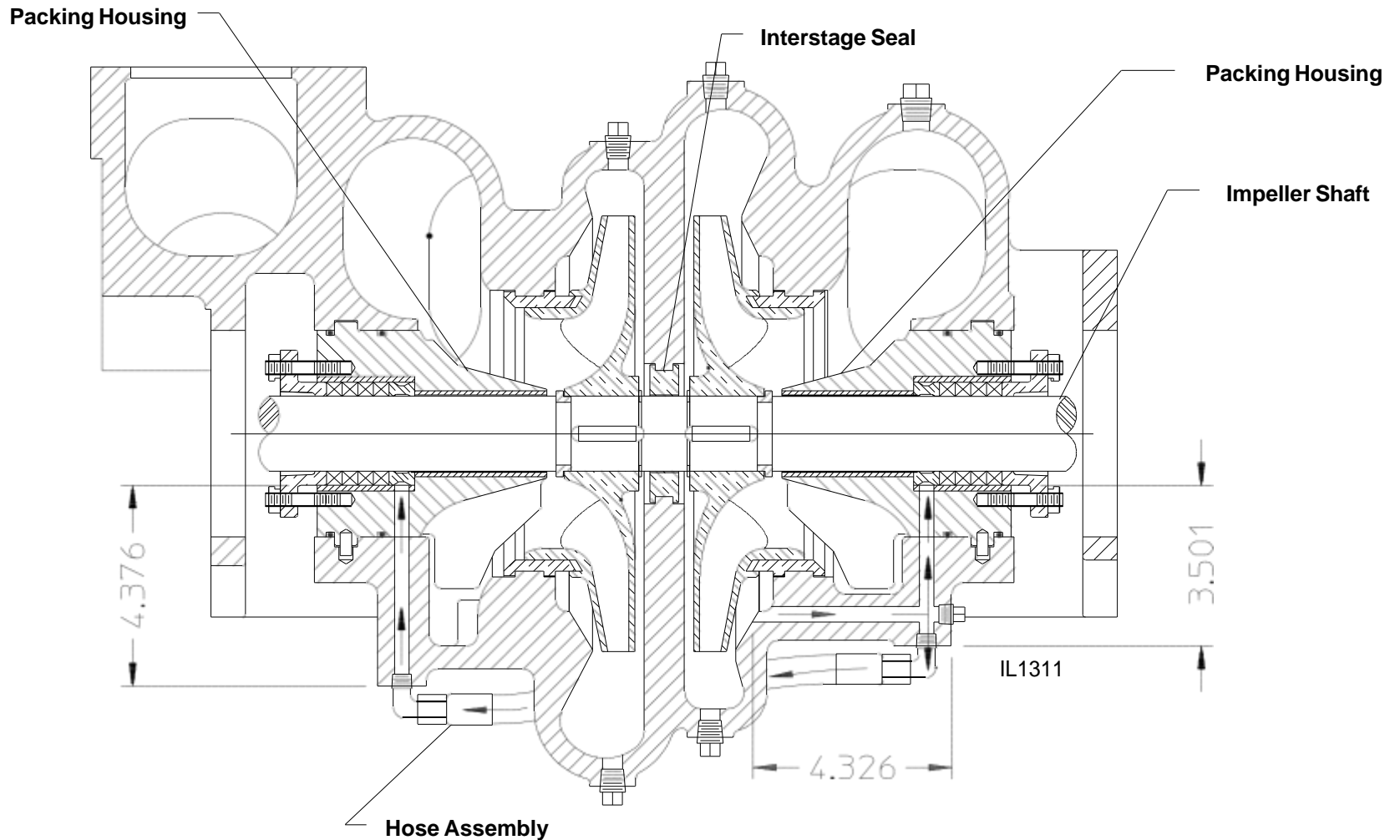

## Install Undersize Wear Rings

IMPELLERS:  
71537/71538 OR  
71537-T/71538-T

1. Check wear rings and impeller hubs for deep grooves or scratches.
2. If inspections shows that the wear ring clearances are excessive (diametral clearance in excess of .025 inches), or if the impeller hubs are scored or grooved, use the dimensions in the tables to rework the hubs.
3. The diametral clearance is determined by averaging the results of four measurements taken at 90° increments as follows:
  - a. Clean and remove small burrs and other protrusions from the wear ring inner diameters and the impeller hubs.
  - b. Position each wear ring on the impeller hub on which it was used.
  - c. Hold the wear ring firmly against one side of the hub and measure total clearance on the opposite side using a feeler gauge.
4. Flame plated impeller hub wear ring clearance is usually restored by installing a replacement wear ring with the same dimensions as the original wear ring since most wear occurs on the wear ring, not the impeller hub. Flame plated impellers are the numbers with the "T" suffix.
5. Non-plated impeller hub wear ring clearance is restored by turning impeller hubs and installing undersize wear rings.
6. Wear rings are available 0.025, 0.050 or 0.075 inches undersize. The tables give the original hub dimension for each impeller and the rework dimensions for each degree of undersize.

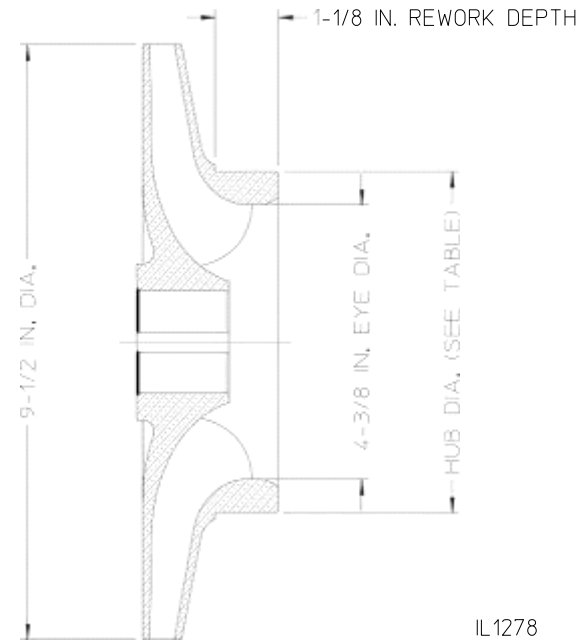

Original Hub Dia	Original Wear Ring No.	Reworked Hub Dia	New Wear Ring No.
<b>Non-plated 5.500 (Min)</b>	72472	5.476/5.473	72472-25
		5.451/5.448	72472-50
<b>Flame Plated 5.494 (Min)</b>		5.426/5.423	72472-75

## Install Undersize Wear Rings - Continued

**IMPELLERS**  
71796/71797 or  
71796-T/71797-T

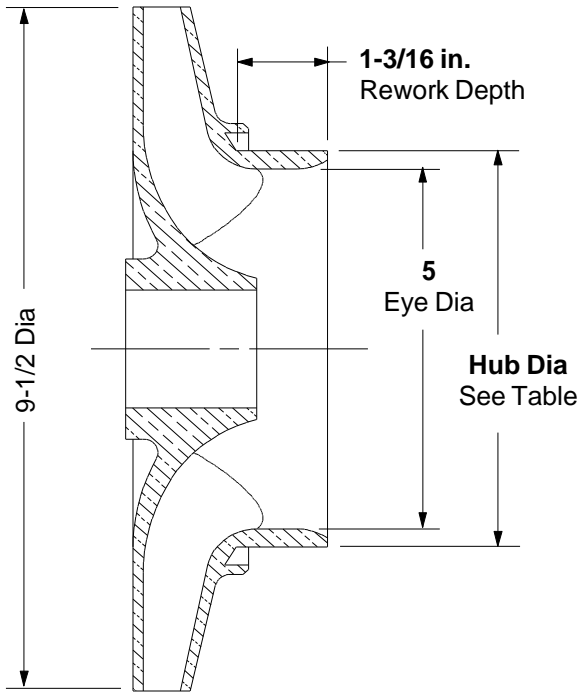

**IMPELLERS**  
71649-T/71650-T

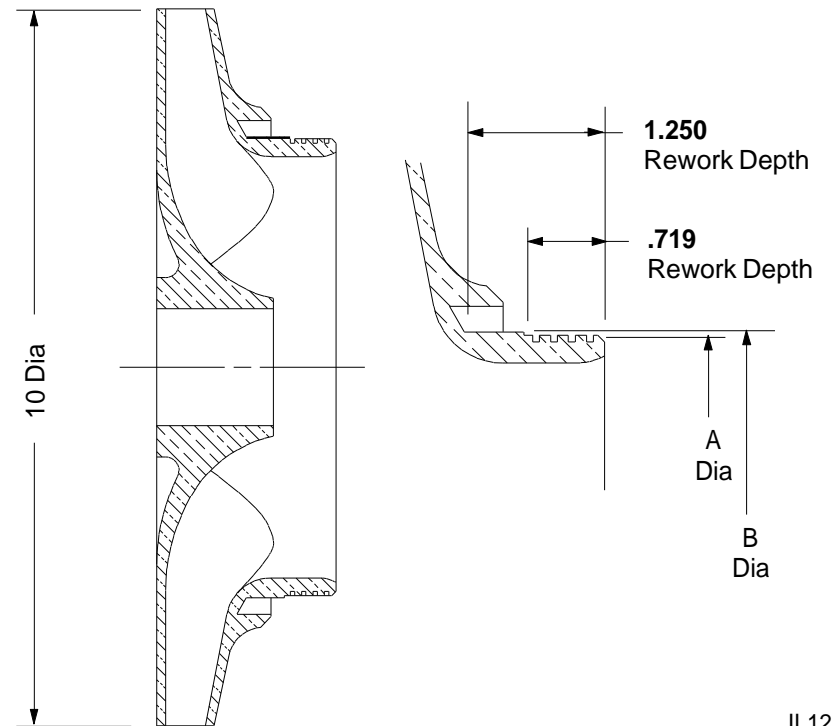

IL1292

Original Hub Dia	Original Wear Ring No.	Reworked Hub Dia	New Wear Ring No.
Non-plated 5.498 (Min)	72403	5.476/5.473	72403-25
Flame Plated 5.494 (Min)		5.451/5.448	72403-50
		5.426/5.423	72403-75

Original Min. Hub Dia	Original Wear Ring No.	Reworked Hub Dia A	Reworked Hub Dia B	New Wear Ring No.
A - 6.368 B - 6.426	72407	6.350/6.348	6.407/6.405	72407-25
		6.325/6.323	6.382/6.380	72407-50
		6.300/6.298	6.357/6.355	72407-75



## Impeller / Wear Ring Installation

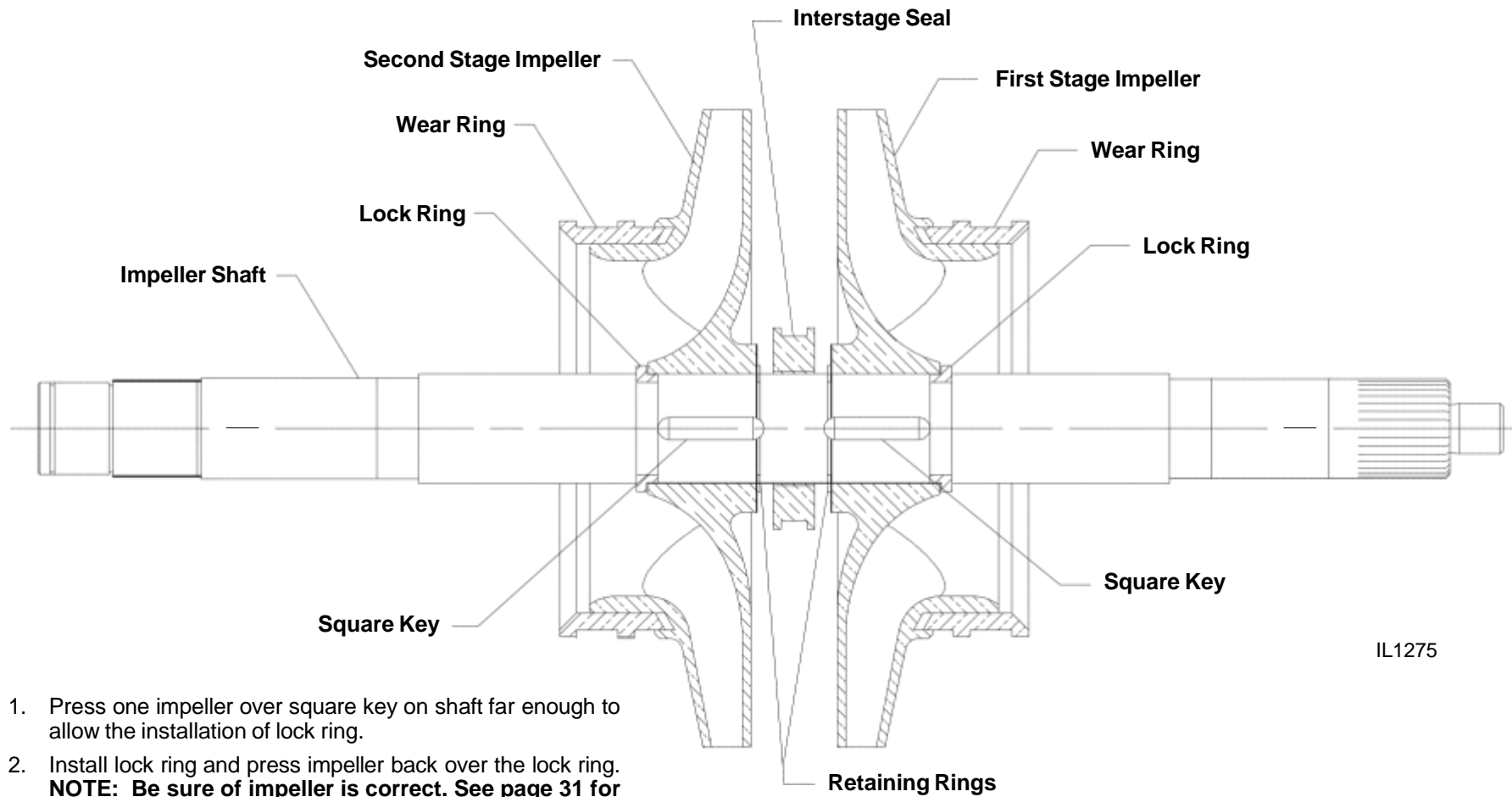

IL1275

1. Press one impeller over square key on shaft far enough to allow the installation of lock ring.
2. Install lock ring and press impeller back over the lock ring.  
**NOTE: Be sure of impeller is correct. See page 31 for impeller rotation.**

### CAUTION

Lock ring halves are a matched set. Do not mix.

3. Install retaining ring, see page 31 for installation tool.
4. Install interstage seal.
5. Repeat process for other impeller.
6. Install wear rings.

# Impeller / Wear Ring Installation Continued

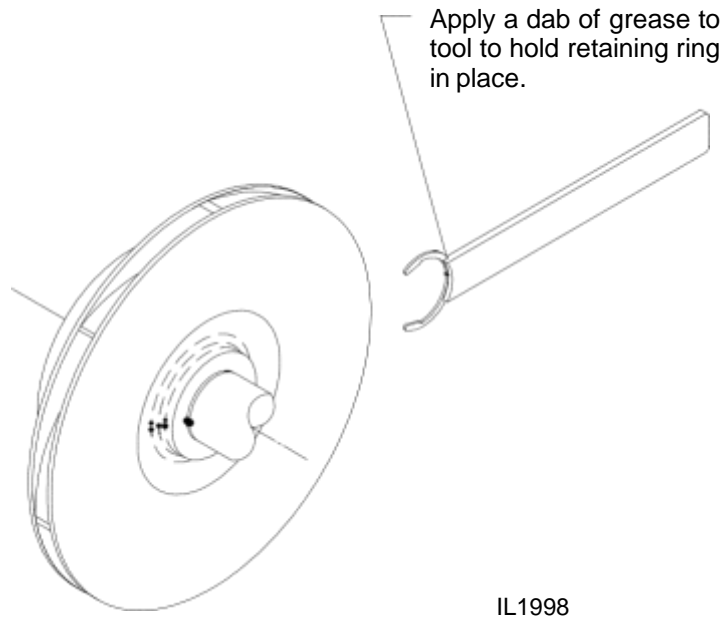

**Retaining Ring Installation Tool  
Part Number 62918**

IL1998

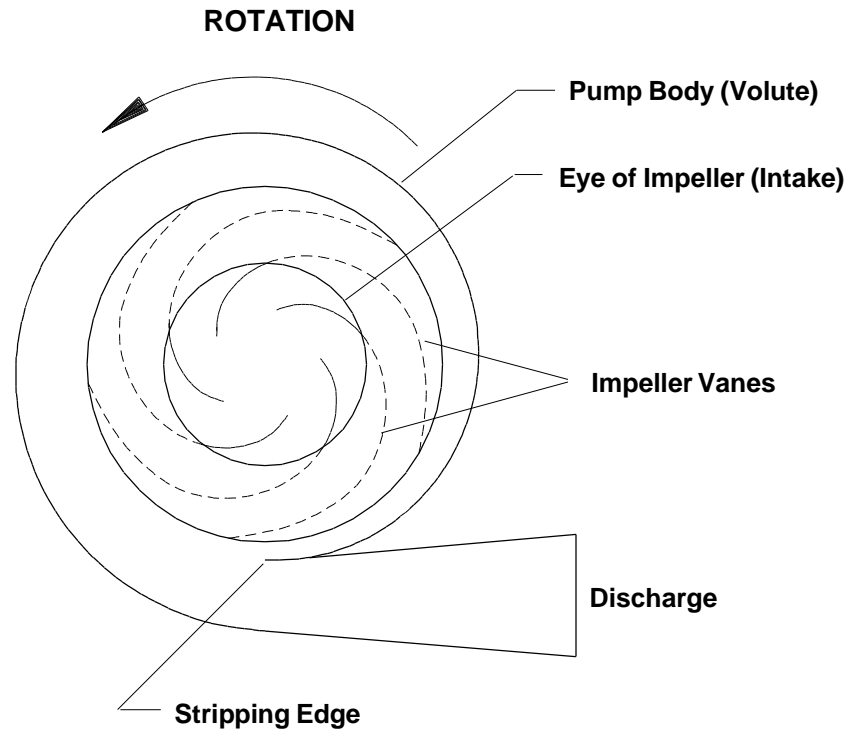

IL1150

# Installing Impeller Shaft Assembly into Pump

(Transmission Mounted Directly to the Rear of the Pump and Rear Driven Direct Drive Pumps)

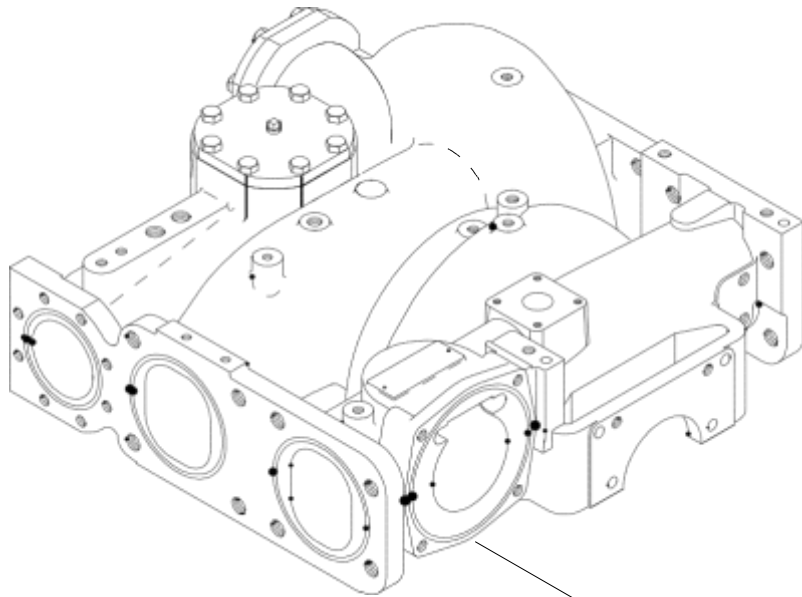

IL1274

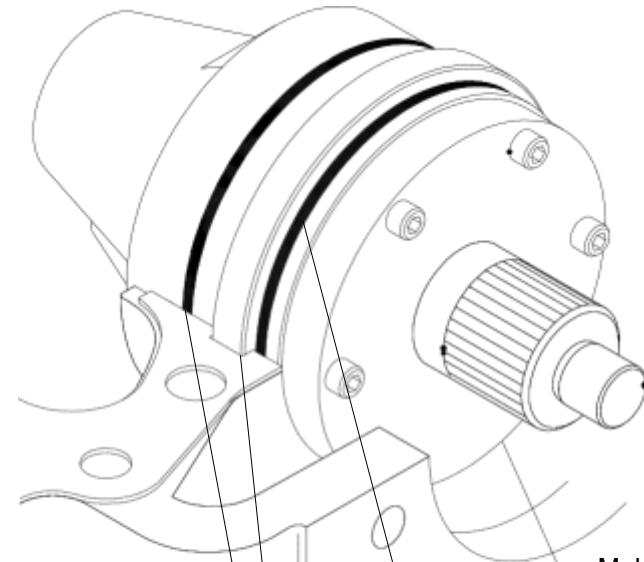

Make sure dowel pin is seated in volute cover.

Apply a pea sized drop of 100% silicone RTV sealant at each of the gasket and O-ring intersection locations (4 per seal housing). Apply silicone prior to gasket installation.

Make sure gasket fits tight against seal housing.

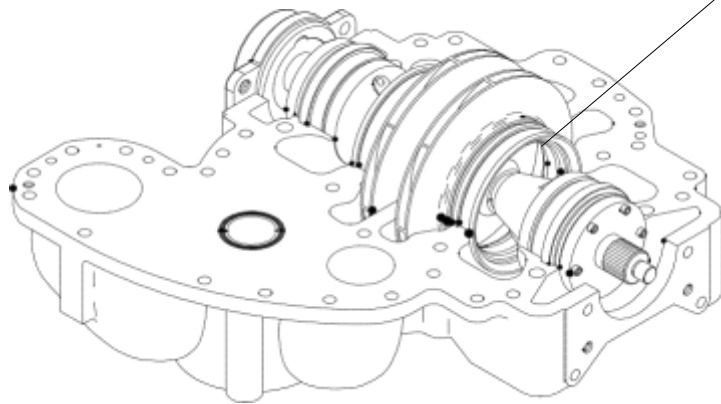

Clean body grooves and bores thoroughly.

Coat seal housings and areas of the body and cover where seal housings are located with Never-Seezr or equivalent.

**NOTE: After reassembling pump, performance test per NFPA 1911, before the truck is placed back in service.**

## Installing Impeller Shaft Assembly into Pump

(Transmission Mounted Directly to the Front of the Pump and Front Driven Direct Drive Pumps)

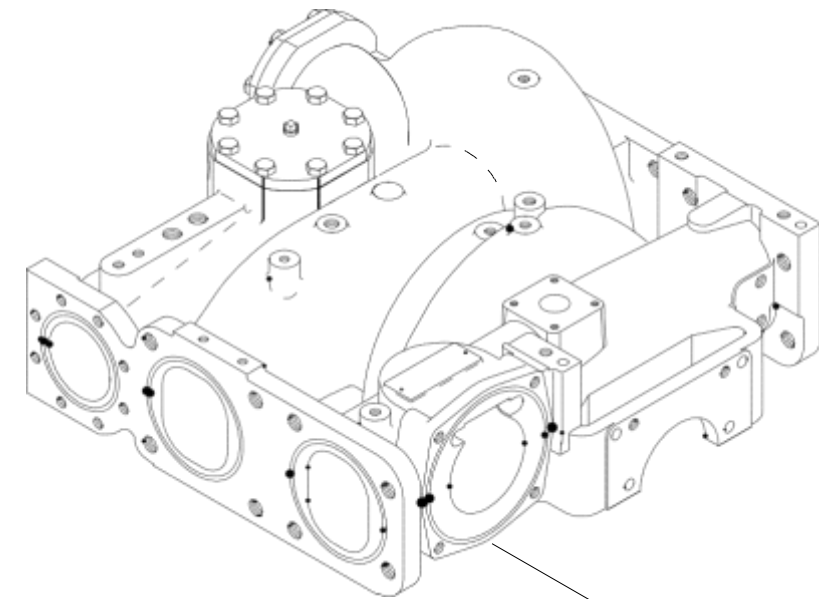

IL1274

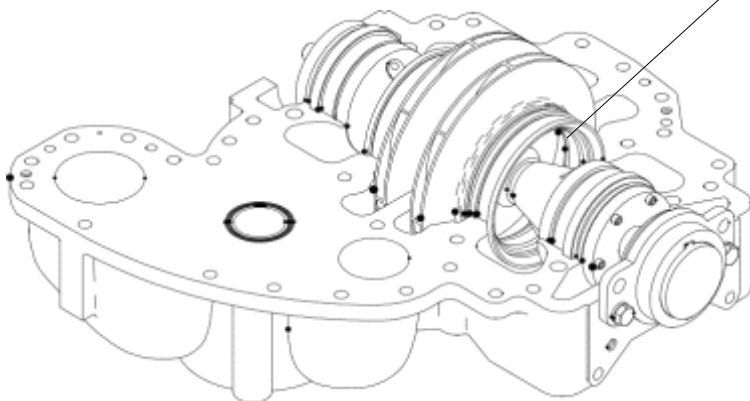

Clean body grooves and bores thoroughly.

Coat seal housings and areas of the body and cover where seal housings are located with Never-Seezr or equivalent.

**NOTE: After reassembling pump, performance test per NFPA 1911, before the truck is placed back in service.**

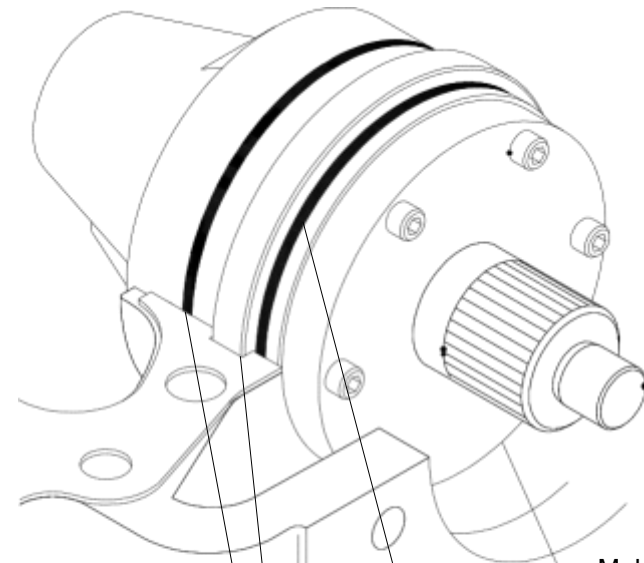

Make sure dowel pin is seated in volute cover.

Apply a pea sized drop of 100% silicone RTV sealant at each of the gasket and O-ring intersection locations (4 per seal housing). Apply silicone prior to gasket installation.

Make sure gasket fits tight against seal housing.

# Installing Body Hardware

## Fastener Size and Torque

Ref Letter	Size	Type		Qty	Torque
		Prior to Aug 27, 2001	After Aug 27, 2001		
A	1/2-13 x 1-1/2 in.	Hex Head	Socket Head	20	105 LB-FT
B	1/2-13 x 1-1/2 in.	Socket Head	Socket Head	1	
C	5/8-11 x 3-1/4 in.	Socket Head	Socket Head	4	
D	1/2-13 x 3-1/2 in.	Hex Head	Socket Head	2	
E	1/2-13 x 4-3/4	Hex Head	Hex Head	6	
F	1/2-13 x 4-3/4	Socket Head	Socket Head	1	
G	1/2-13 x 1 in.	Hex Head	Hex Head	3	75 LB-FT

## Fastener Tightening Sequence

Sequence	Screws Numbered
First	1, 2, 3, 4, 5
Second	6, 7, 8, 9
Third	10, 11, 12, 13
Fourth	14 to 26
Fifth	27 to 34
Sixth	35, 36, 37

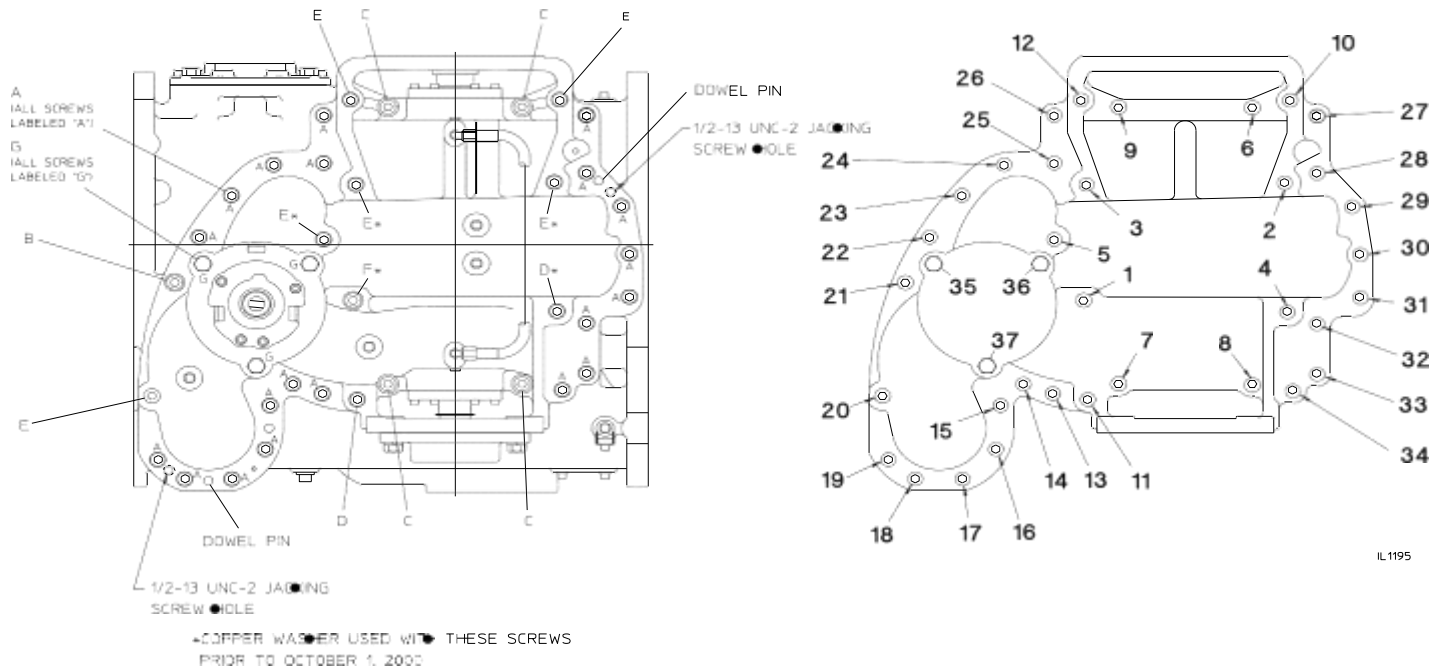

## Mechanical Seal Removal

### (Without Disassembling the Pump)

1. Replacing the mechanical seal will be easier when using the special tools designed by Waterous Company. These tools may be purchased from Waterous Company or fabricated by the user.

*K956                      Outboard bearing removal/installation tools*

*K628                      Mechanical seal removal/installation tools*

### Parts of Kit K 628 Mechanical Seal Removal / Installation Tools

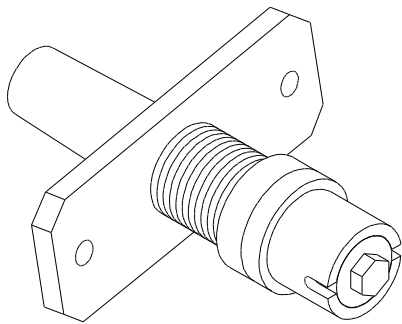

**REMOVAL TOOL**  
**P/N 72385**

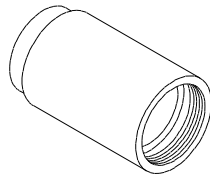

**TOOL PROTECTION SLEEVE/INSTALLATION TOOL**  
(Use as a cover to protect removal tool threads when not in use)  
**P/N 62896 PART OF 72385**

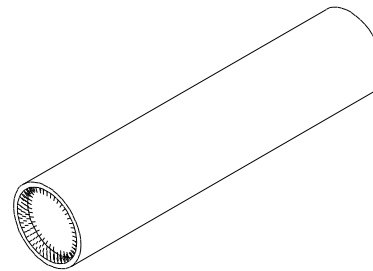

**IMPELLER SHAFT BRUSH**  
**P/N V 2633**

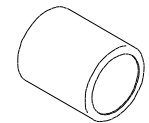

**INSTALLATION SLEEVE**  
**P/N 52280**

2. Whenever a mechanical seal requires replacement, the Waterous Service Department strongly recommends replacing both seals; outboard bearing and drive end. **NOTE: Always replace the outboard seal and bearing assembly first.**

# Mechanical Seal Removal

(Without Disassembling the Pump)

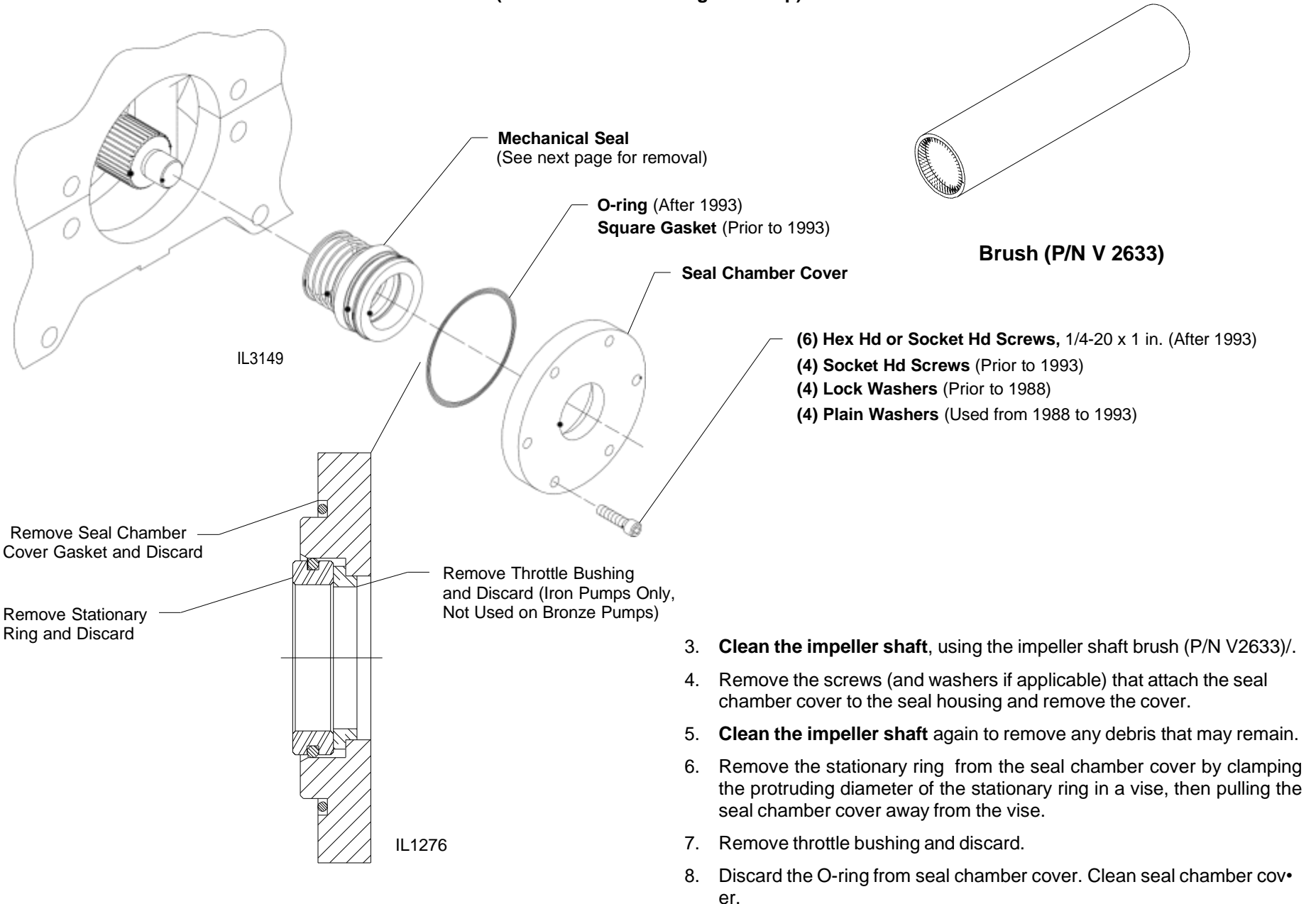

## Mechanical Seal Removal

(Without Disassembling the Pump)

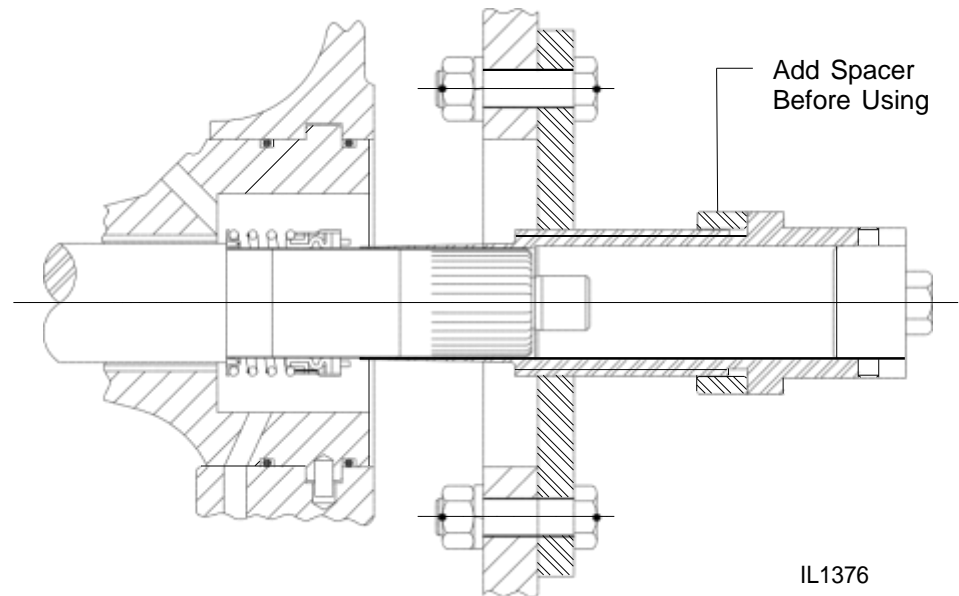
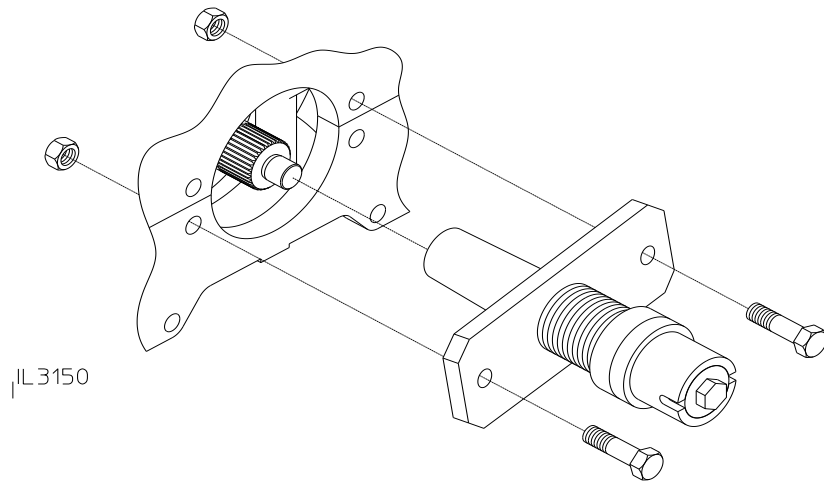

9. Attach the mechanical seal removal tool to the pump body using two of the mounting holes in the body and the screws and nuts from the bearing housing. The plate must be flush with the pump body, but tighten screws hand-tight only.
10. Turn the hex head on the removal tool clockwise until it touches seal, then 1 inch to 1-1/4 inch further (the primary ring in the mechanical seal may break from the force).

11. Turn the hex head on the removal tool counterclockwise to remove the seal.
12. Remove the tool and the seal.
13. Remove spring retainer and spring if they do not come out with the seal. Clean seal chamber and impeller shaft.
14. Clean the sealing surface behind the seal chamber cover on the seal housing.



## Mechanical Seal Installation - Continued

### CAUTION

The entire mechanical seal installation procedure shall be completed without interruption. Delays may cause seal bellows to seat improperly.

Whenever a mechanical seal requires replacement, the Waterous Service Department strongly recommends replacing both seals; outboard bearing and drive end.

**Note: Always replace the seal and bearing on outboard end first.**

1. Inspect the new primary ring and stationary ring sealing surfaces. These surfaces should be "mirror smooth" and without scratches. To identify the stationary ring sealing surface examine the outside diameter of the ring. There is a chamfer towards the backside and the o-ring is close to the back.

### CAUTION

Try not to touch the "mirror smooth" surfaces. If surfaces are touched clean surface with denatured alcohol and a soft cloth.

### CAUTION

The mechanical seal primary and stationary rings are made of brittle material. The material can be cracked or chipped. Extra care must be taken when handling these rings.

2. Sub-Assemble seal chamber cover. See Figure 1. Install a new throttle bushing in the seal chamber cover. (A throttle bushing is not used on bronze pumps.) Install new stationary ring with new O-ring in the seal chamber cover, the mirror smooth seal surface should be visible, the chamfered O.D. edge should seat on the throttle bushing. Install new seal chamber cover O-ring gasket in the seal chamber cover.

### CAUTION

The throttle bushing must be seated properly to avoid misalignment of the mating surfaces of the mechanical seal.

3. Install seals. See Figures 2 and 3.
  - a. On the outboard end of the pump, install the installation sleeve on the shaft which will allow the seal to slip over the shaft shoulder. Failure to use the installation sleeve may cause damage to the seal. Liberally coat shaft and sleeve with lubricant (supplied with kit) before installing the mechanical seal.
  - b. Place spring retainer and spring on the shaft. Coat inside of mechanical seal bellows with lubricant and push seal on with installation tool until the

spring retainer makes contact with shaft shoulder. Continue pushing the seal until the spring is fully compressed. Remove the installation tool slowly allowing the spring to relax. Remove the protection sleeve from the shaft (outboard end only).

### CAUTION

Do not get lubricant on the sealing surfaces on the stationary ring or primary ring. If surfaces get lubricant on them clean with a soft cloth and denatured alcohol.

**Note: If Waterous Mechanical Seal Lubricant part no. 52608 is not available, P80 rubber lubricant, straight dish soap or glycerin may be substituted.**

4. Install seal chamber cover. See Figure 4.
  - a. Be sure the stationary ring, O-ring, throttle bushing and O-ring gasket are installed in seal chamber cover (See Step 2).
  - b. Install the seal chamber cover on the shaft and slowly push on with installation tool. The seal chamber cover will guide the mechanical seal into place. When the cover contacts the pump body, attach with the screws previously removed during disassembly.

**Note: Before proceeding, both replacement seals (outboard and drive end) and the outboard bearing should be installed. As recommended earlier, both seals should be replaced at the same time. Outboard end seal and bearing assembly should be completed first.**

5. Turn impeller shaft by hand at least two revolutions in both a clockwise and counterclockwise direction to seat seals.
6. Hydrostatically test pump at 150 P.S.I.G. Observe impeller shaft at throttle bushing and intersection of the seal chamber cover with pump body split line for leaks. Turn impeller shaft by hand while retaining the hydrostatic pressure to see if there is leakage between the throttle bushing and impeller shaft. If leakage persists, after one or two minutes of rotation (10 to 12 turns) disassemble and inspect.

# Mechanical Seal Installation - Continued

**Figure 1. Seal Chamber Cover Sub-Assembly**

1. Install new throttle bushing (iron Pumps Only)
2. Install new seal stationary ring.
3. Install new gasket or O-ring.

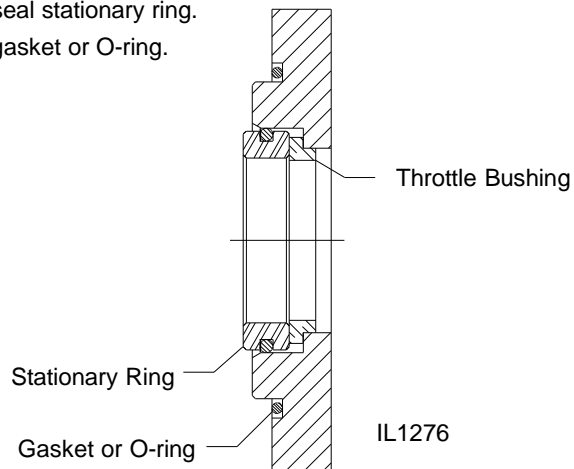

**Figure 3. Transmission End Seal Installation**

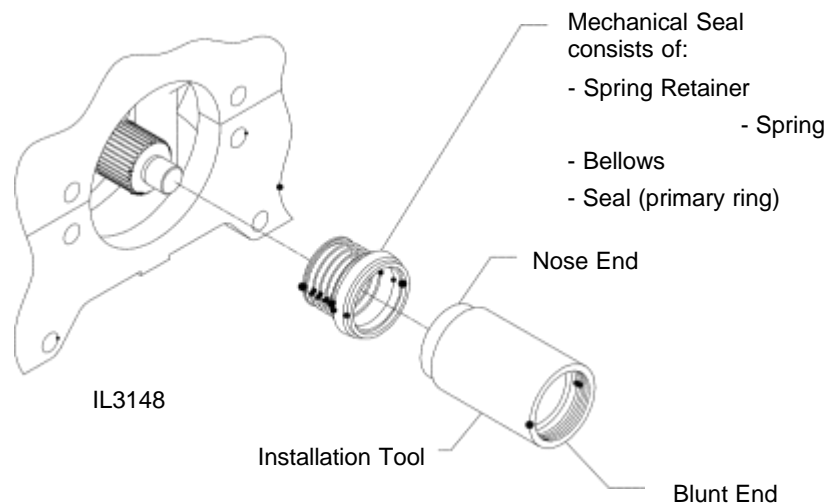

**Figure 2. Outboard Bearing End Seal Installation**

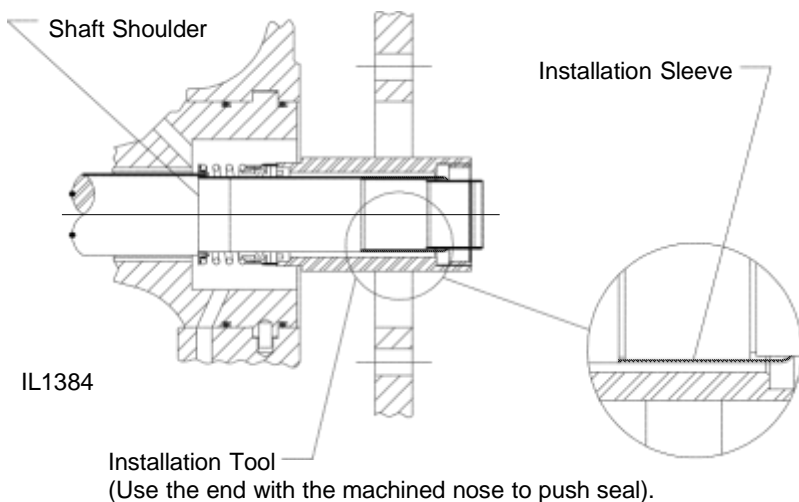

**Figure 4. Seal Chamber Cover Installation**

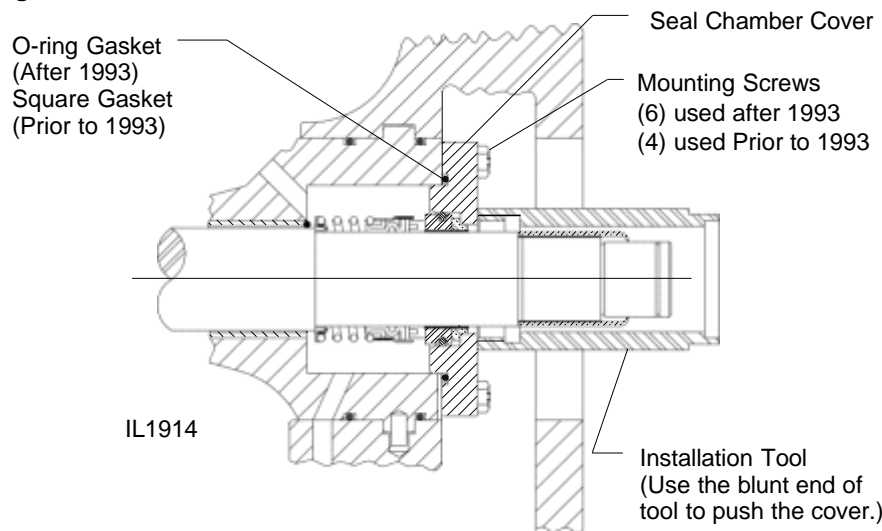

## Packing - Braided Flexible Graphite (BFG)

Waterous uses a braided graphite fiber, with reinforced flexible graphite yarns and high purity graphite filament yarns that appear on the corners as well as throughout the body of the packing. The graphite reinforcement allows the flexible graphite yarns to provide greater tensile strength.

This type of packing reduces the frictional heat created between the shaft and the I.D. of the packing. By dissipating the heat through the cross section of the packing, the heat is transferred to the packing gland and the seal housing.

### Packing Removal

#### WARNING

**Truck movement hazard.**  
**May cause serious personal injury.**

Stop engine, set the parking brake and chock the wheels before going under truck to remove packing.

1. Remove the unbalanced nuts, flat washers and packing gland halves from one end of the pump.
2. Engage the pump per appropriate operating instructions. Operate the pump gradually increasing the discharge pressure until the packing is forced out of the seal housing. Pressure in excess of 300 psi (20.7 bar) may be required.

#### CAUTION

**Pump overheating hazard.**  
**May cause damage to the pump.**

Circulate enough water through the pump to prevent overheating. Do not pressurize the pump over the rated maximum discharge pressure of the pump.



#### WARNING

**Packing Gland and Pump Body Temperature Hazard. May result in serious burns.**

Heat is dissipated through the cross-section of the packing, transferring the heat to the packing gland and pump body.

3. If all the packing is not forced out, it may be necessary to remove the remaining packing by hand, using a pick or similar device. Waterous has a packing removal tool (P/N 5782) available for this purpose.
4. Replace packing per instructions below, repeating the procedure for the opposite end of the pump.

#### Packing Removal

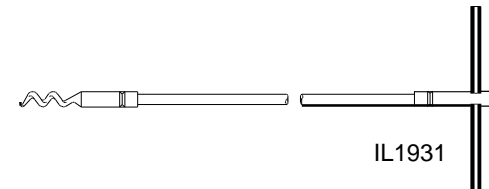

## Packing Installation

1. Before installing the new packing, be sure that all of the old packing is removed from the seal housing.
2. Be sure that the seal housing and the shaft are clean and free of any packing residue.
3. Lightly lubricate the packing ring I.D. and O.D. with mineral oil, automotive grease or engine oil for installation purposes.
4. Make sure packing is clean.
5. Carefully install one ring of packing. With the aid of packing glands, push the packing into the seal housing as far as possible. Repeat this operation with each ring, staggering the joints at least 90° apart. Install the packing rings until the top of the last ring is about 1/4 inch from the end of the seal housing (at least 1/8 inch is required for the packing gland nose entrance into the stuffing box).
6. Install packing glands, nuts and washers. Tighten gland nuts one flat beyond finger tight.

**NOTE:** The milled slot on the nut should face the gland.

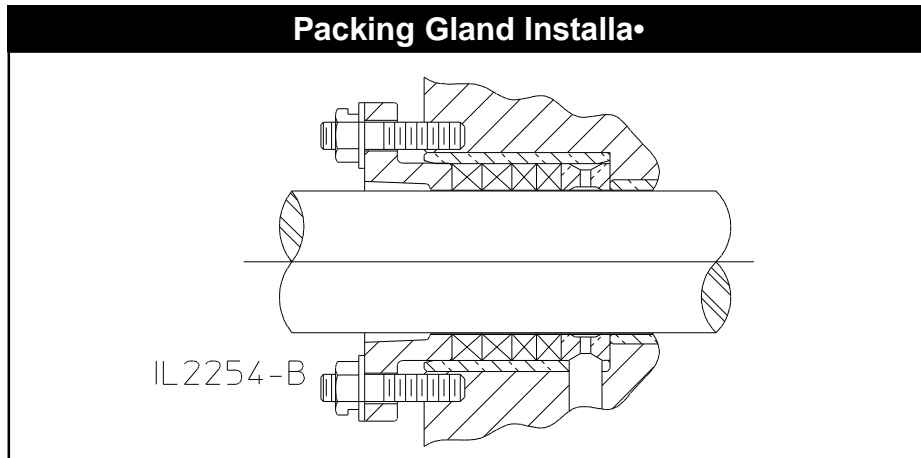

7. Adjust packing as required per instructions on the next page.

## Packing Adjustment

The pump packing is designed and adjusted to drip slightly during operation. This is to cool and lubricate the packing. It is desirable to adjust the stuffing box to maintain a leakage rate of 10 to 120 drops per minute when operating at a discharge pressure of 150 psi (10.3 bar).

Leakage through the braided flexible graphite (BFG) packing may be at zero or diminish to zero leakage and may not respond to loosening of the packing nuts to restore leakage, see Adjustment Step 3. While the packing gland and stuffing box and pump body may reach high temperatures during this time, the impeller shaft will be protected from heat damage.

### CAUTION

**Pump overheating hazard.  
May cause damage to the pump.**

Circulate enough water through the pump to prevent overheating.



### WARNING

**Truck movement hazard.  
May cause serious personal injury.**

Stop engine, set the parking brake and chock the wheels before going under truck to adjust packing.

1. Engage pump per appropriate operating instructions. Operate the pump at the capacity pressure shown on the serial plate for ten (10) minutes.

### CAUTION

**Observe the stuffing box drip rate from the side of the truck.**

2. Observe leakage. Normal leakage is 10-120 drops per minute.



### WARNING

**Packing Gland and Pump Body Temperature Hazard. May result in serious burns.**

Heat is dissipated through the cross-section of the packing, transferring the heat to the packing gland and pump body.

3. If drip rate is considered high, stop the engine and tighten the packing gland nuts 1/2 to 1 flat (maximum of 1/6 of a revolution). Make appropriate adjustments starting with 1 flat, when approaching the final adjustment reduce to 1/2 flat. This reduces the possibility of over tightening. **Tighten the gland nuts equally to ensure that the packing gland goes on straight.** Gradually reducing leakage during the first hour of operation will result in a better seal over a longer period of time. Adjust the drip rate on one stuffing box until the appropriate rate is obtained, then proceed to the other end of the pump.

### CAUTION

**Stopping the leakage entirely at this point will cause the packing to overheat.**

4. Operate the pump at the capacity pressure shown on the serial plate for two (2) minutes to let packing run in, then observe the drip rate.
5. Repeat steps 3 and 4 until the drop rate is acceptable.

**NOTE: After adjusting the packing, the pump must pass the following vacuum test described below.**

### Vacuum Test

1. Remove all caps except openings without valves. Close all discharge, intake and drain valves and other similar openings. Operate priming device to create a vacuum of about 22 in. Hg/.735 atmosphere in pump, then stop primer and engine.
2. Watch the pressure gauge; if vacuum drops more than 10 in. Hg/.334 atmospheres in five (5) minutes, listen for air leaks around the packing gland, gaskets, valves, etc.
3. Replace gaskets, re-adjust packing, repack or otherwise repair source of trouble.
4. Repeat test.

## Rotary Style - Bottom Mounted Manual Transfer Valve Actuator Removal/Installation (After 2000)

1. If possible, rotate the transfer valve to the VOLUME position before removal.
2. Remove manual assembly by removing spirol pin, 1/8 x 3/4, from U-joint. Then slide entire assembly out from gear case shaft.
3. Remove transfer valve actuator assembly by removing hex socket head screws, 5/16-18 x 5/8 and (3) lock washers, 5/16.
4. Extension shaft may come loose from transfer valve actuator. Make sure key, 3/16 x 1-1/4, is in place when reinstalling extension shaft. This will ensure proper alignment.
5. For repair of the transfer valve actuator subassembly, refer to form F-1031, Section 2315, *Transfer Valve Actuator Overhaul Instructions*.
6. When reinstalling transfer valve actuator, make sure extension shaft is turned to the volume position. To find out if actuator is in the volume position, check under mounting bracket for a stamped arrow with the letter "V" for volume. The arrow indicates the direction in which the extension shaft must be fully rotated to be in volume position. Turn opposite way to be in pressure position. Pump mode should also be in volume position to ensure that extension shaft and groove pin from transfer valve ball will properly align when reinstalling actuator to pump. Use alignment marks as shown on attached page, "Bottom View of Transfer Valve Ball in Volume Position."

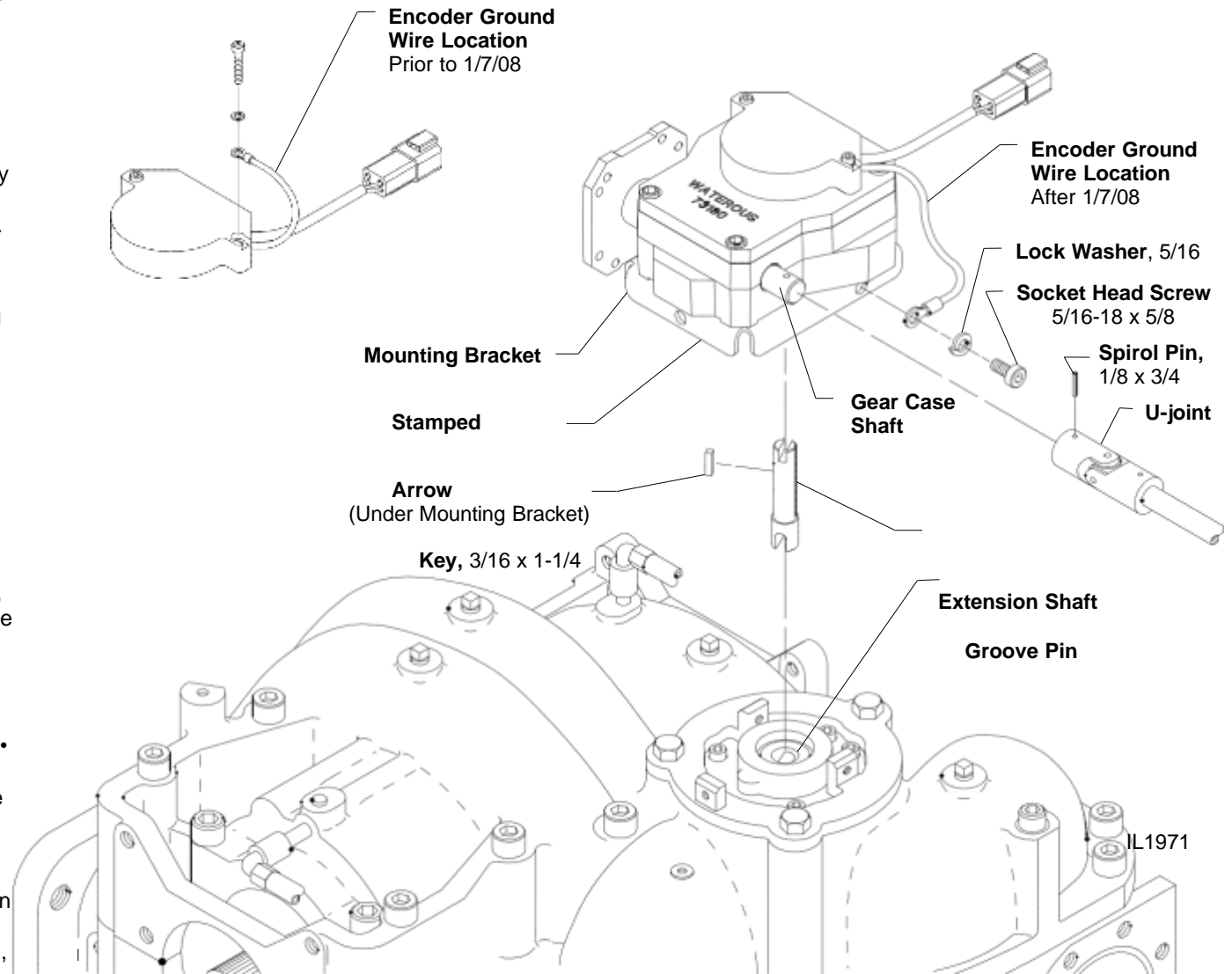

**NOTE: The gear case shaft must be used to turn the extension shaft.**

## Rotary Style - Bottom Mounted Electric Transfer Valve Actuator Removal/Installation (After 2000)

1. If possible, rotate the transfer valve to the VOLUME position before removal.
2. If transfer valve actuator is equipped with optional manual override, remove this first by removing spirol pin, 1/8 x 3/4, from U-joint. Then slide entire assembly out from gear motor shaft.
3. Remove transfer valve actuator assembly by removing socket head screws, 5/16-18 x 5/8 and (3) lock washers, 5/16 and (3) lock washers, 5/16.
4. Extension shaft may come loose from transfer valve actuator. Make sure key, 3/16 x 1-1/4 (3/16 x 3/4 on actuators built prior to 4/21/06), is in place when reinstalling extension shaft. This will insure proper alignment.
5. For repair of the transfer valve actuator subassembly, refer to form F-1031, Section 2315, *Transfer Valve Overhaul Instructions*.
6. When reinstalling transfer valve actuator, make sure extension shaft is turned to the volume position. To find out if actuator is in the volume position, check under mounting bracket for a stamped arrow with the letter "V" for volume. The arrow indicates the direction in which the extension shaft must be fully rotated to be in volume position. Turn opposite way to be in pressure position. Pump mode should also be in volume position to ensure that extension shaft and groove pin from transfer valve ball will properly align when reinstalling actuator to pump. Use alignment marks as shown on attached page, "Bottom View of Transfer Valve Ball in Volume Position."

**NOTE: The gear motor shaft must be used to turn the extension shaft.**

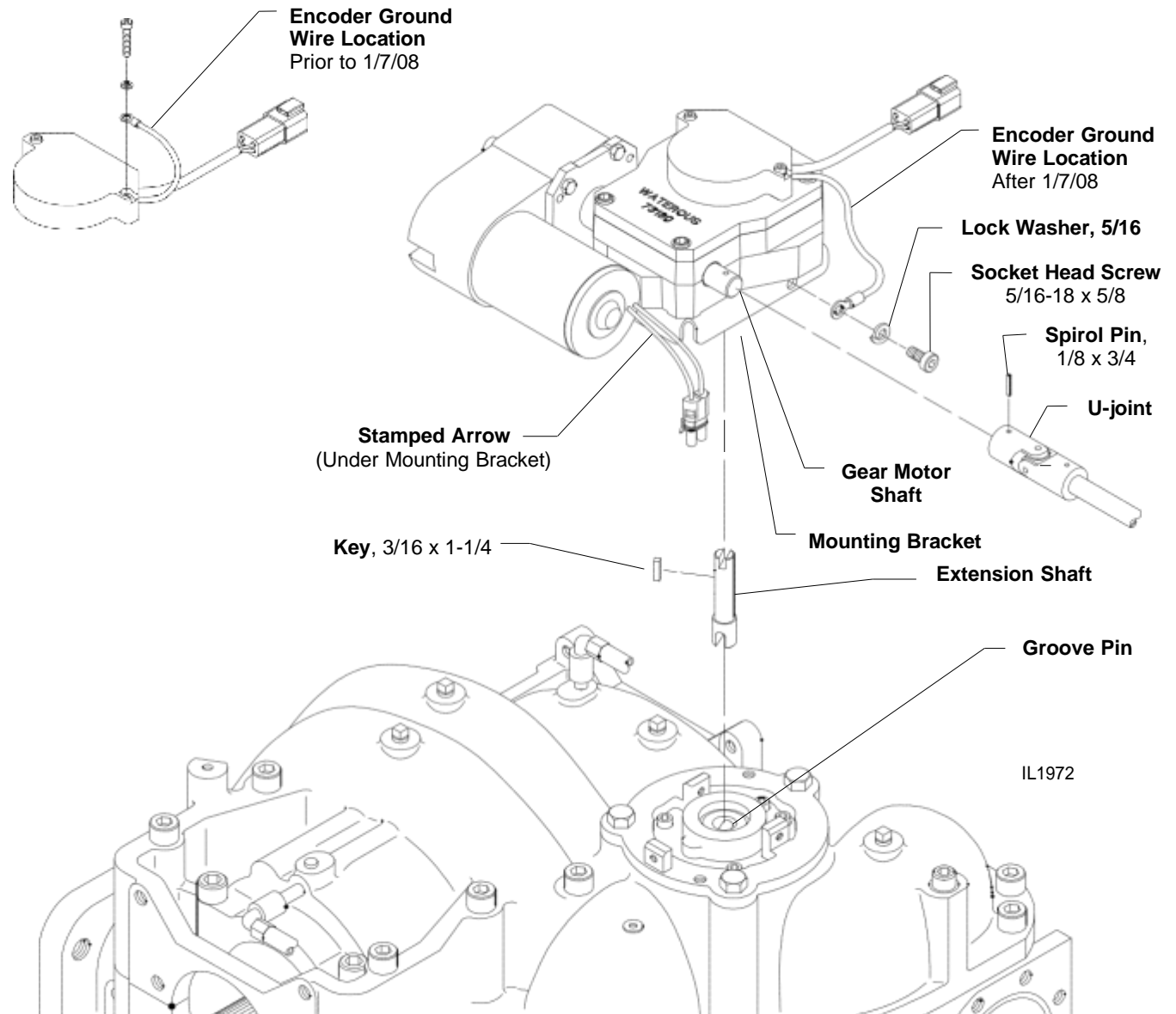

## Rotary Style - Top Mounted Manual Transfer Valve Actuator Removal/Installation (After 2000)

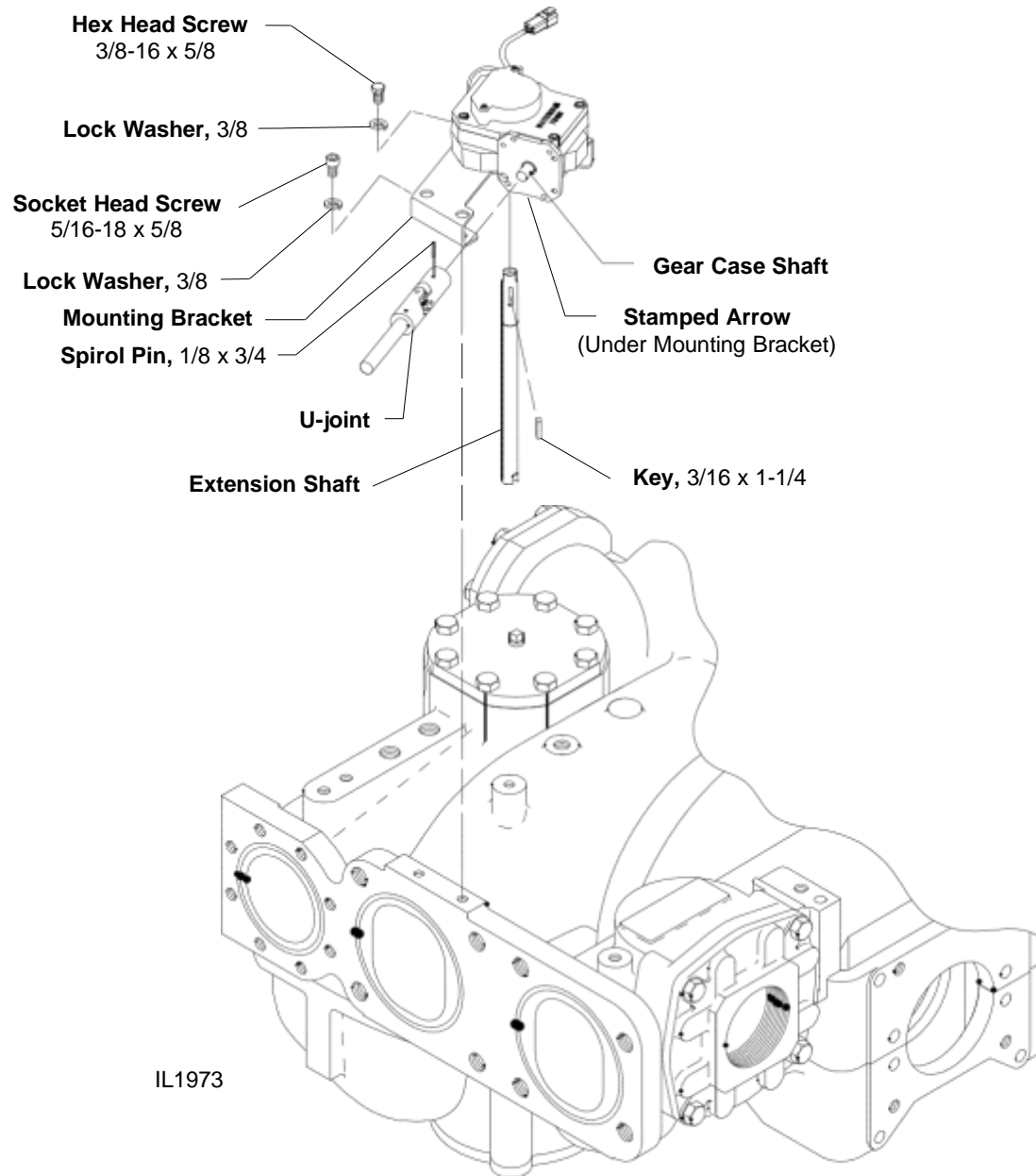

1. If possible, rotate the transfer valve to the VOLUME position before removal.
2. Remove manual assembly by removing spirol pin, 1/8 x 3/4, from U-joint. Then slide entire assembly out from gear case shaft.
3. Remove transfer valve actuator assembly by removing (1) hex head screw, 3/8-16 x 5/8, (2) socket head screws, 5/16-18 x 5/8 and (3) lock washers, 3/8.
4. Extension shaft may come loose from transfer valve actuator. Make sure key, 3/16 x 1-1/4, is in place when reinstalling extension shaft. This will ensure proper alignment.
5. For repair of the transfer valve actuator sub-assembly, refer to form F-1031, Section 2315, *Transfer Valve Overhaul Instructions*.
6. When reinstalling transfer valve actuator, make sure extension shaft is turned to the volume position. To find out if actuator is in the volume position, check under mounting bracket for a stamped arrow with the letter "V" for volume. The arrow indicates the direction in which the extension shaft must be fully rotated to be in volume position. Turn opposite way to be in pressure position. Pump mode should also be in volume position to ensure that extension shaft and groove pin from transfer valve ball will properly align when reinstalling actuator to pump. Use alignment marks as shown on attached page, "Bottom View of Transfer Valve Ball in Volume Position."

**NOTE: The gear case shaft must be used to turn the extension shaft.**

IL1973



## Rotary Style - Top Mounted Electric Transfer Valve Actuator Removal/Installation (After 2000)

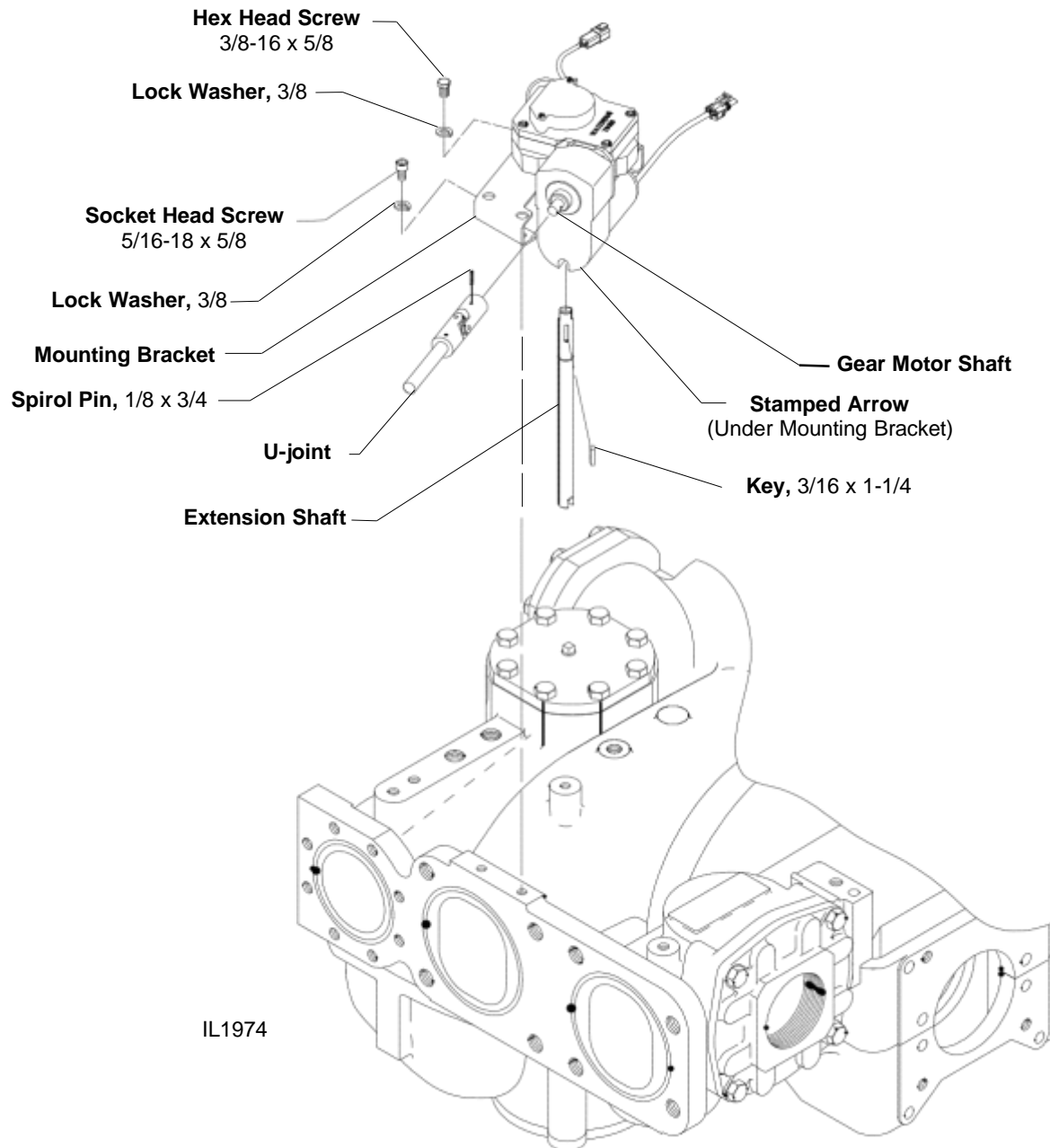

IL1974

1. If possible, rotate the transfer valve to the VOLUME position before removal.
2. If transfer valve actuator is equipped with optional manual override, remove this first by removing spirol pin, 1/8 x 3/4, from U-joint. Then slide entire assembly out from gear motor shaft.
3. Remove transfer valve actuator assembly by removing (1) hex head screw, 3/8-16 x 5/8, (2) hex socket head screws, 3/8-16 x 5/8 and (3) lock washers, 3/8.
4. Extension shaft may come loose from transfer valve actuator. Make sure key, 3/16 x 1-1/4, is in place when reinstalling extension shaft. This will ensure proper alignment.
5. For repair of the transfer valve actuator sub-assembly, refer to form F-1031, Section 2315, *Transfer Valve Overhaul Instructions*.
6. When reinstalling transfer valve actuator, make sure extension shaft is turned to the volume position. To find out if actuator is in the volume position, check under mounting bracket for a stamped arrow with the letter "V" for volume. The arrow indicates the direction in which the extension shaft must be fully rotated to be in volume position. Turn opposite way to be in pressure position. Pump mode should also be in volume position to ensure that extension shaft and groove pin from transfer valve ball will properly align when reinstalling actuator to pump. Use alignment marks as shown on attached page, "Bottom View of Transfer Valve Ball in Volume Position."

**NOTE: The gear motor shaft must be used to turn the extension shaft.**

## Transfer Valve Removal/Replacement for Rotary Style Actuator (After 2000)

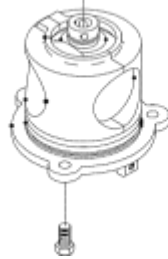
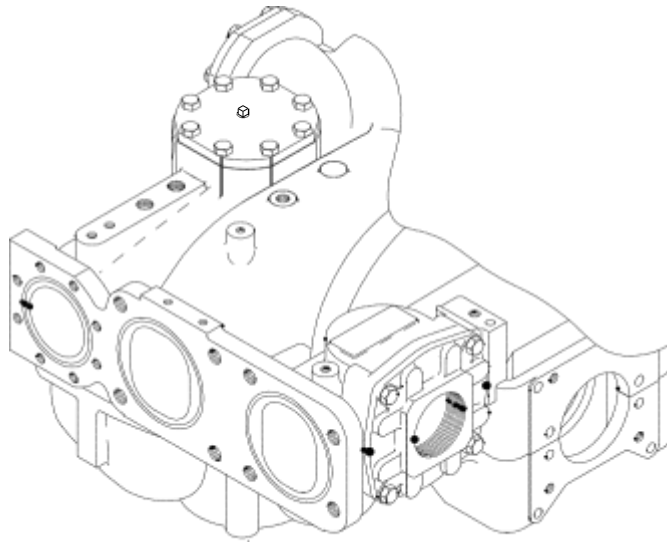

IL1975

Socket Head Screw,  
5/16-18 x 3/4 (4)

Hex Head Screw,  
1/2-13 x 1 (3)

Jacking Screw Holes

Transfer Valve Cover

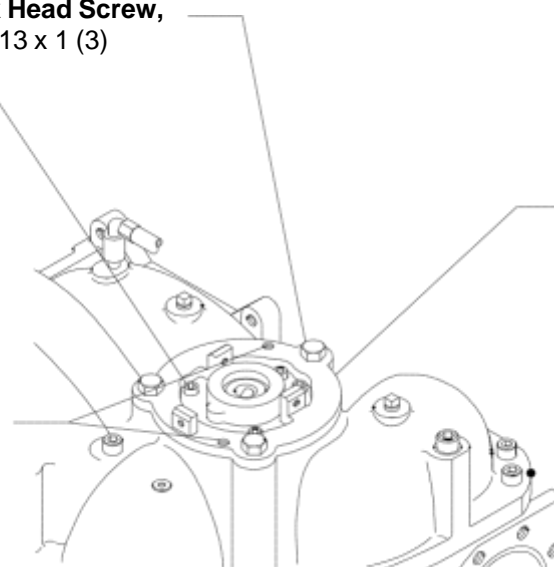

**NOTE: The transfer valve only needs to be removed and disassembled if it needs to be repaired.**

There is repair kit available for replacing the seals in the transfer valve.

1. Remove the (3) hex head screws, 1/2-13 x 1 that attach the transfer valve cover to the pump body. Do not remove the (4) socket head screws, 5/16-18 x 3/4 until the transfer valve has been removed from the pump assembly.
2. Use jacking screw holes to remove cover/transfer valve assembly from the body assembly.

## Transfer Valve Removal / Installation for Rotary Style Actuator (After 2000)

**NOTE:** The transfer valve only needs to be removed and disassembled if it needs to be repaired or updated.

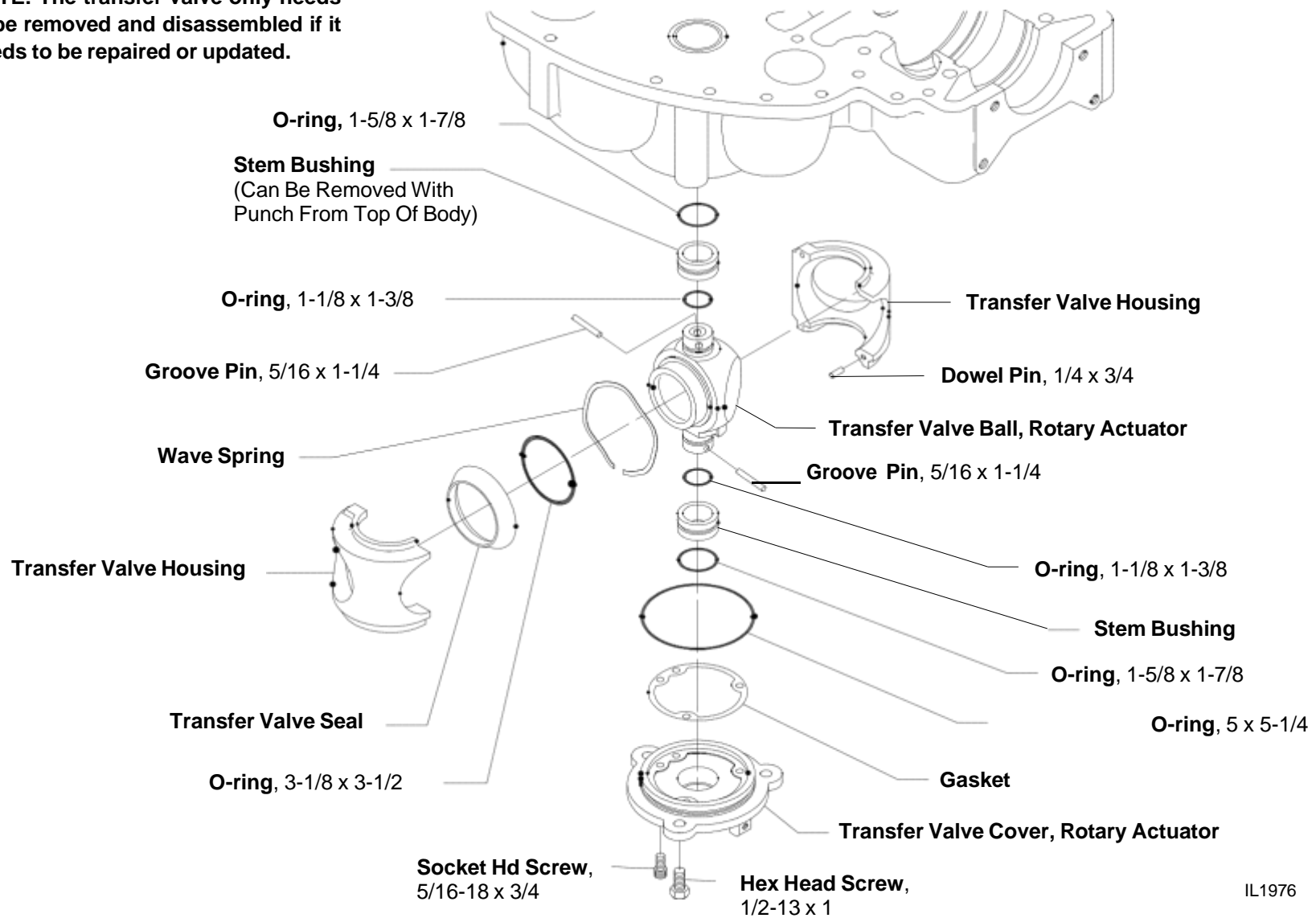

## View Of Assembled Transfer Valve without Transfer Valve Cover for Rotary Style Actuator (After 2000)

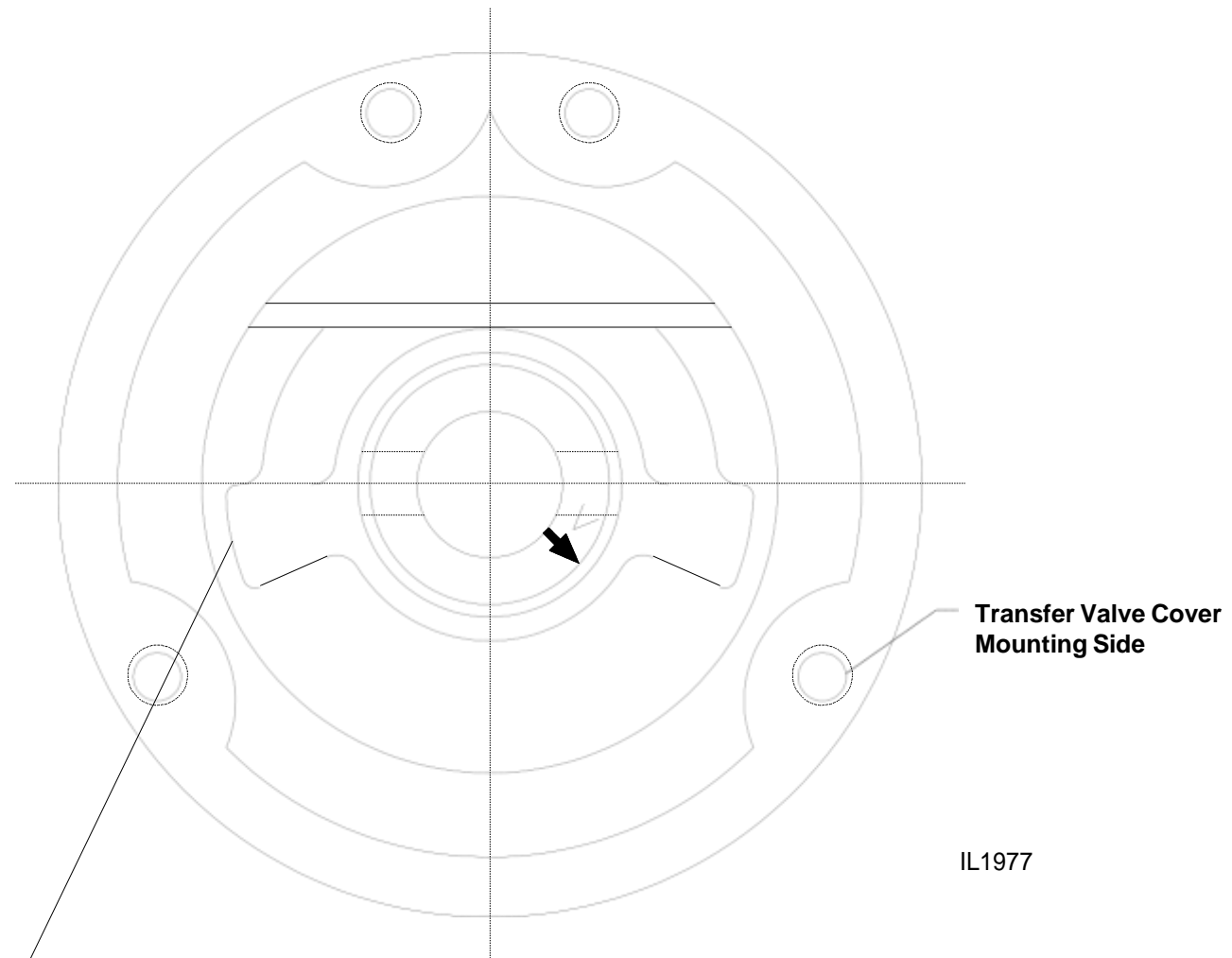

When reassembling transfer valve, make sure cast stops on transfer valve ball are located on transfer valve cover mounting side. This will ensure that transfer valve ball is not assembled upside down.

## Bottom View Transfer Valve in Volume Position for Rotary Style Actuator (After 2000)

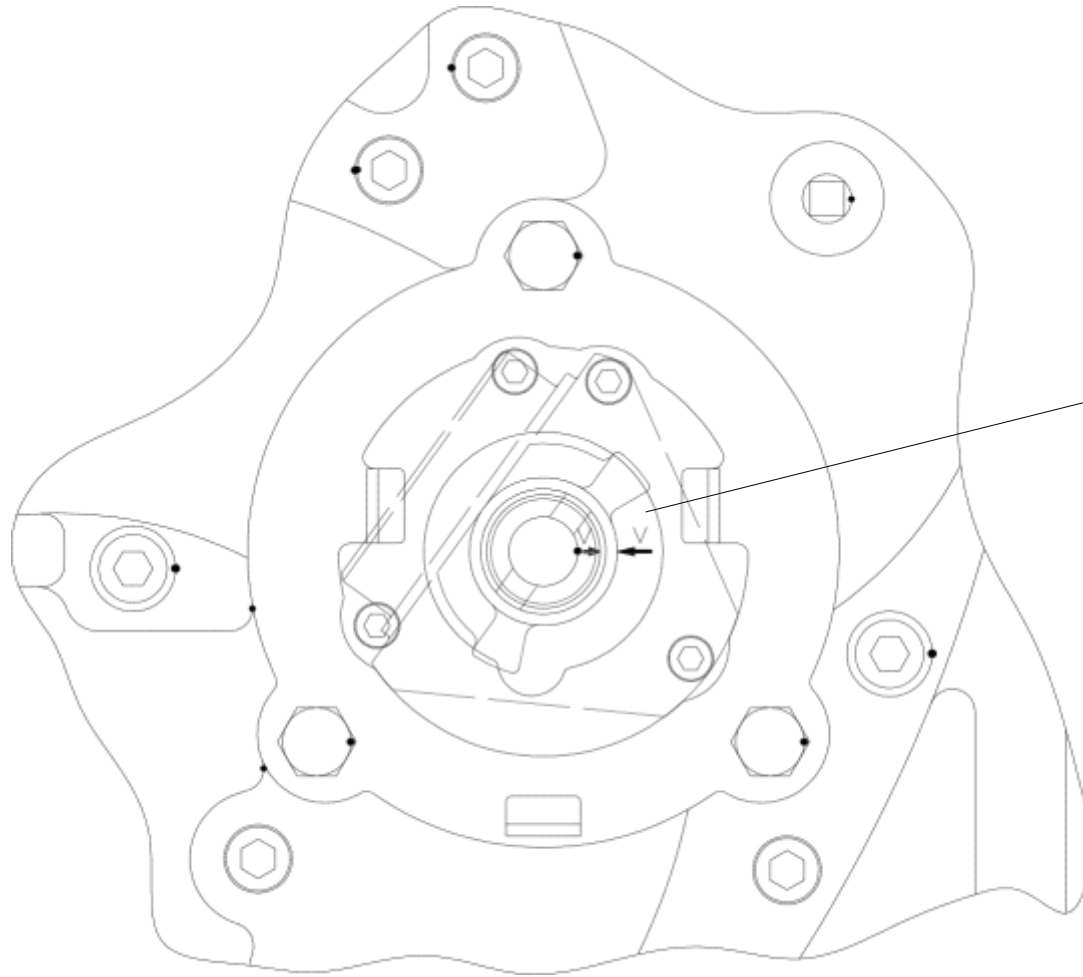

Assemble transfer valve ball in the Volume Position as shown. Stamped arrows with the letter "V" on the transfer ball and transfer valve cover must be aligned to be in Volume Position. This is to ensure that the transfer valve ball is in alignment with the extension shaft when reinstalling the transfer valve actuator to pump.

IL2072

## Reciprocating Actuator Removal/Installation - Bottom Mounted Manual Transfer Valve (Prior to 2000)

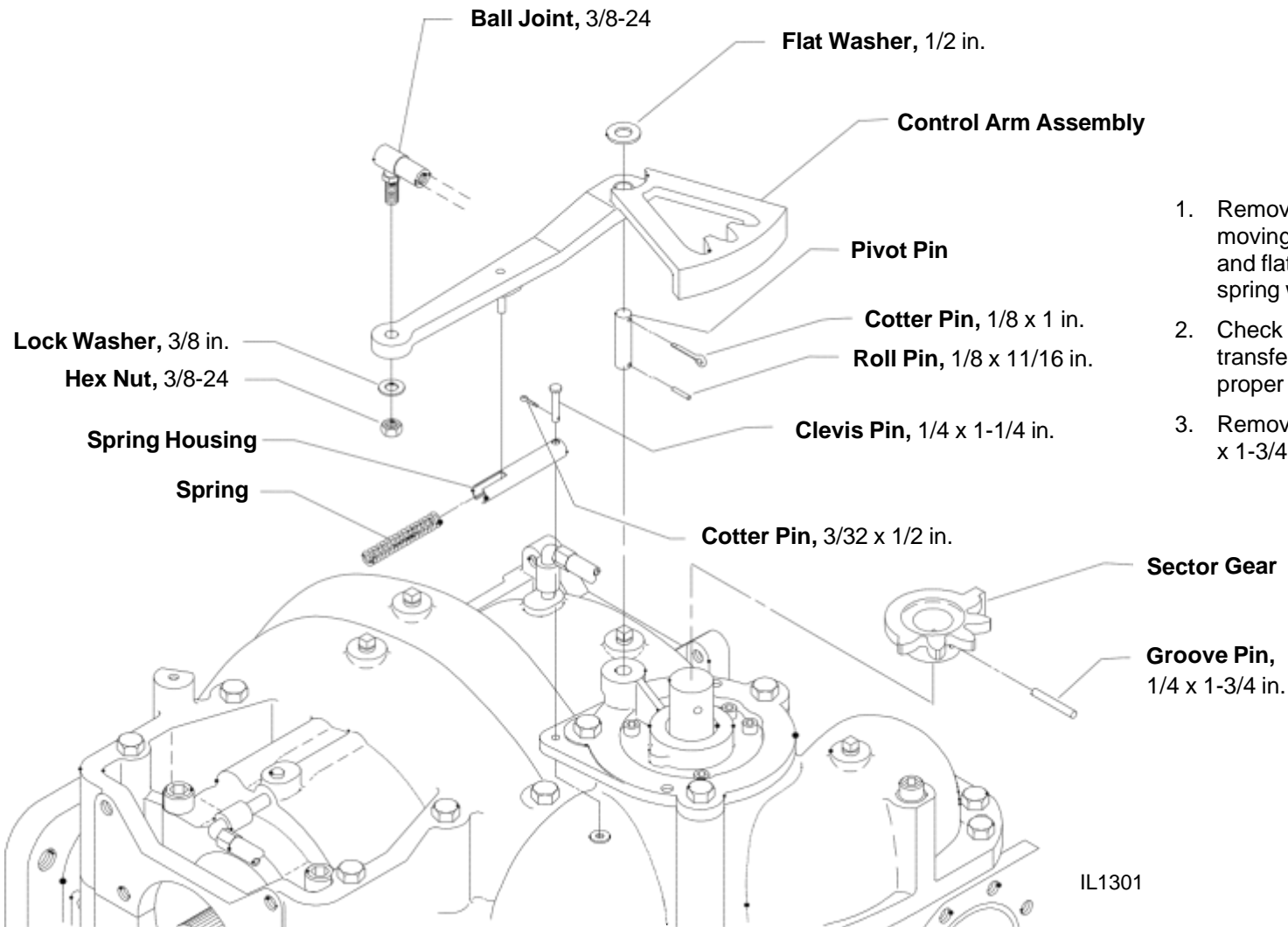

1. Remove control arm assembly by removing ball joint, 1/8 x 1 in. cotter pin and flat washer. Be careful not to lose spring when removing arm.
2. Check to make sure sector gear and transfer valve stem are marked to aid in proper reassembly.
3. Remove sector gear by driving out 1/4 x 1-3/4 in. groove pin.

## Reciprocating Actuator Removal/Installation - Bottom Mounted Electric Transfer Valve (Prior to 2000)

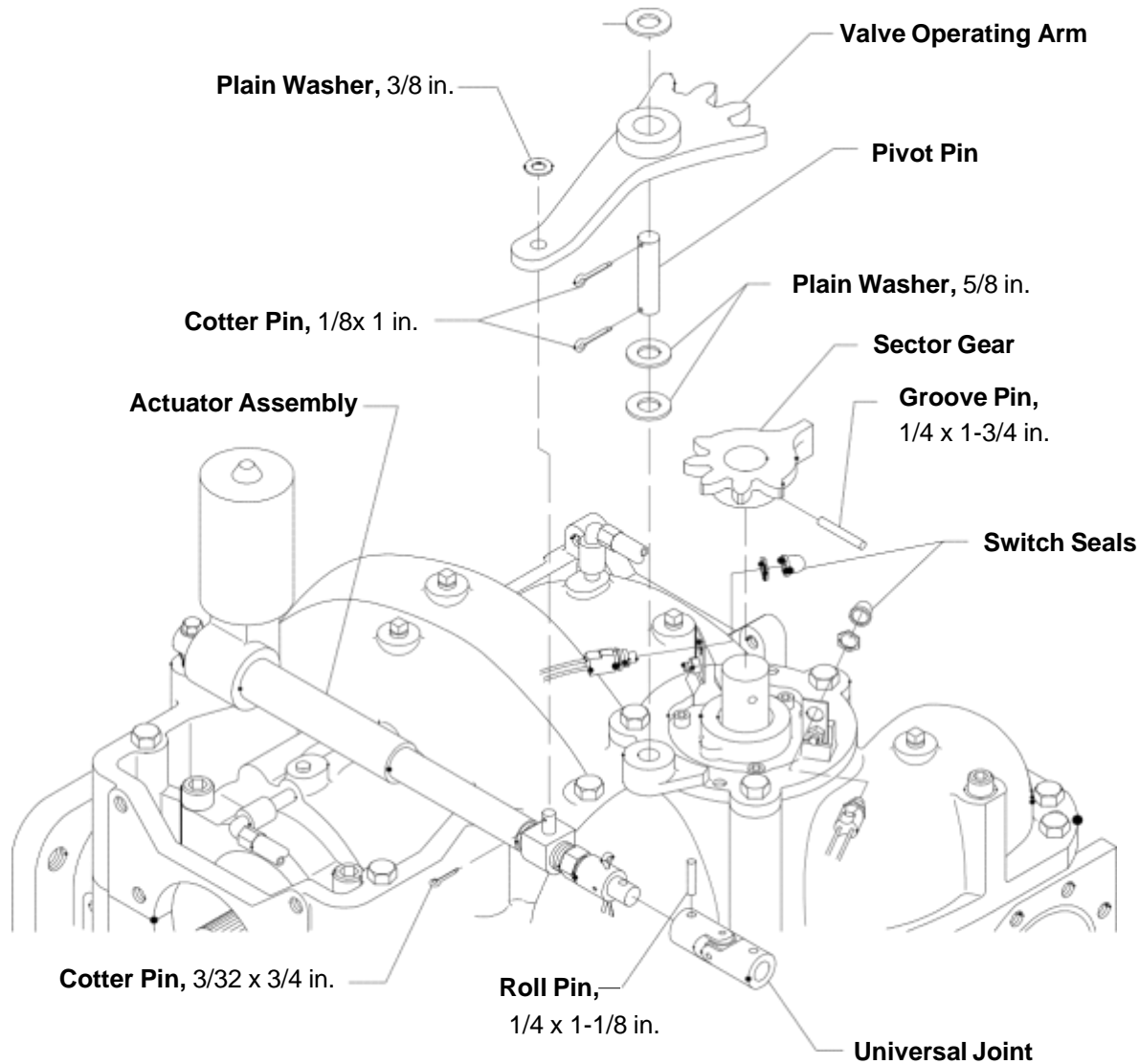

1. Disconnect actuator assembly from operating arm by removing 3/32 x 3/4 in. cotter pin and 3/8 in. plain washer.
2. Swing aside the actuator. It may be necessary to remove the override from the end of the actuator, (if so equipped) by removing 1/4 x 1-1/8 in. roll pin and universal joint.
3. Remove operating arm from the transfer valve cover by removing 1/8 x 1 in. cotter pin and 5/8 in. plain washers.
4. Check to make sure sector gear and transfer valve stem are marked to aid in proper reassembly.
5. Remove sector gear by driving out 1/4 x 1-3/4 in. groove pin.
6. Remove switch seal and disconnect switch assembly.

IL1302

## Reciprocating Actuator Removal/Installation - Top Mounted Manual Transfer Valve (Prior to 2000)

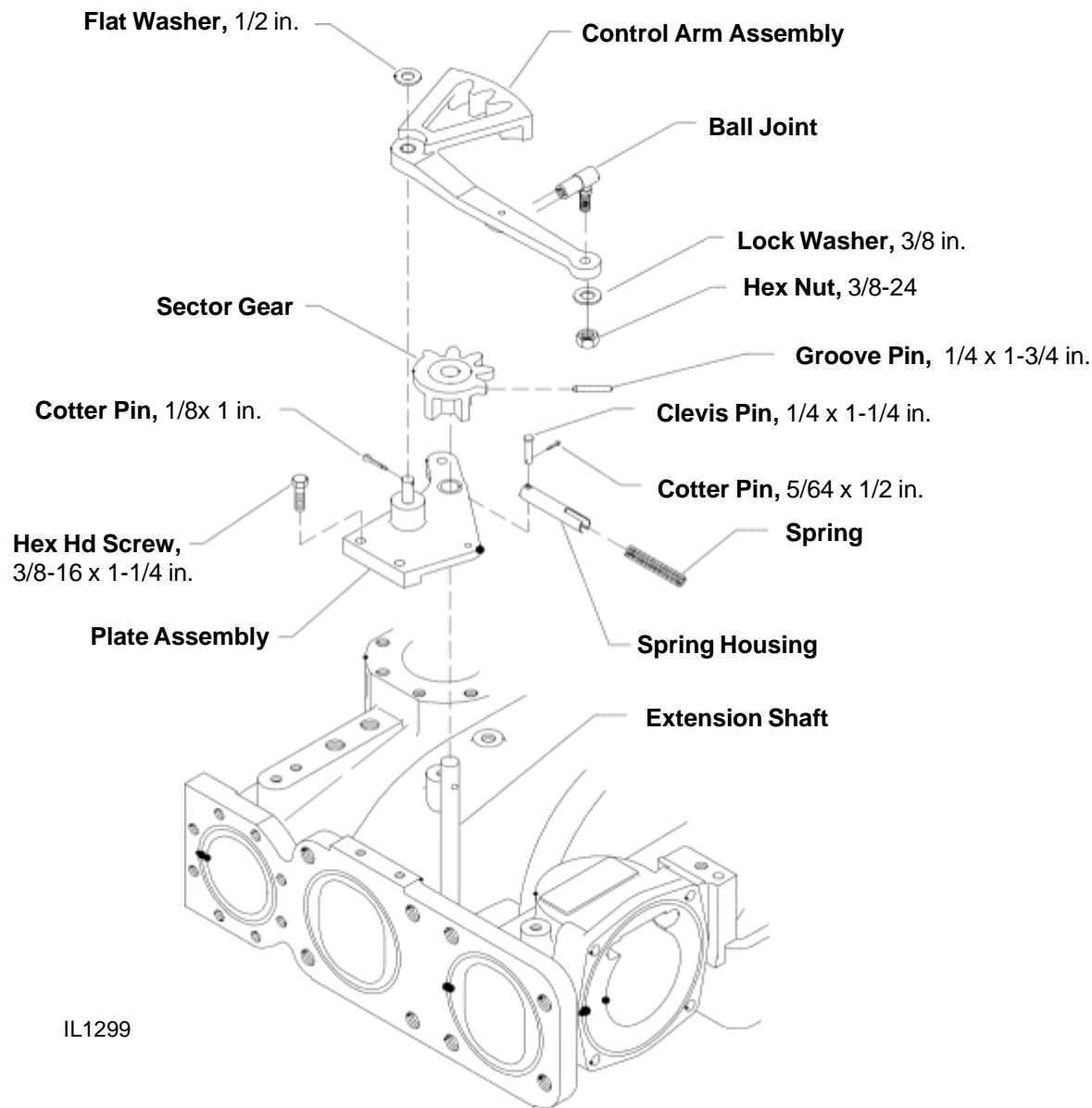

1. Remove control arm assembly by removing ball joint and 1/8 x 1 in. cotter pin and flat washer. Be careful not to lose spring when removing arm assembly.
2. Check to make sure sector gear and extension shaft are marked to aid in proper reassembly.
3. Remove 1/4 x 1-3/4 groove pin and sector gear from extension shaft.

IL1299



# Reciprocating Actuator Removal/Installation - Top Mounted Electric Transfer Valve (Prior to 2000)

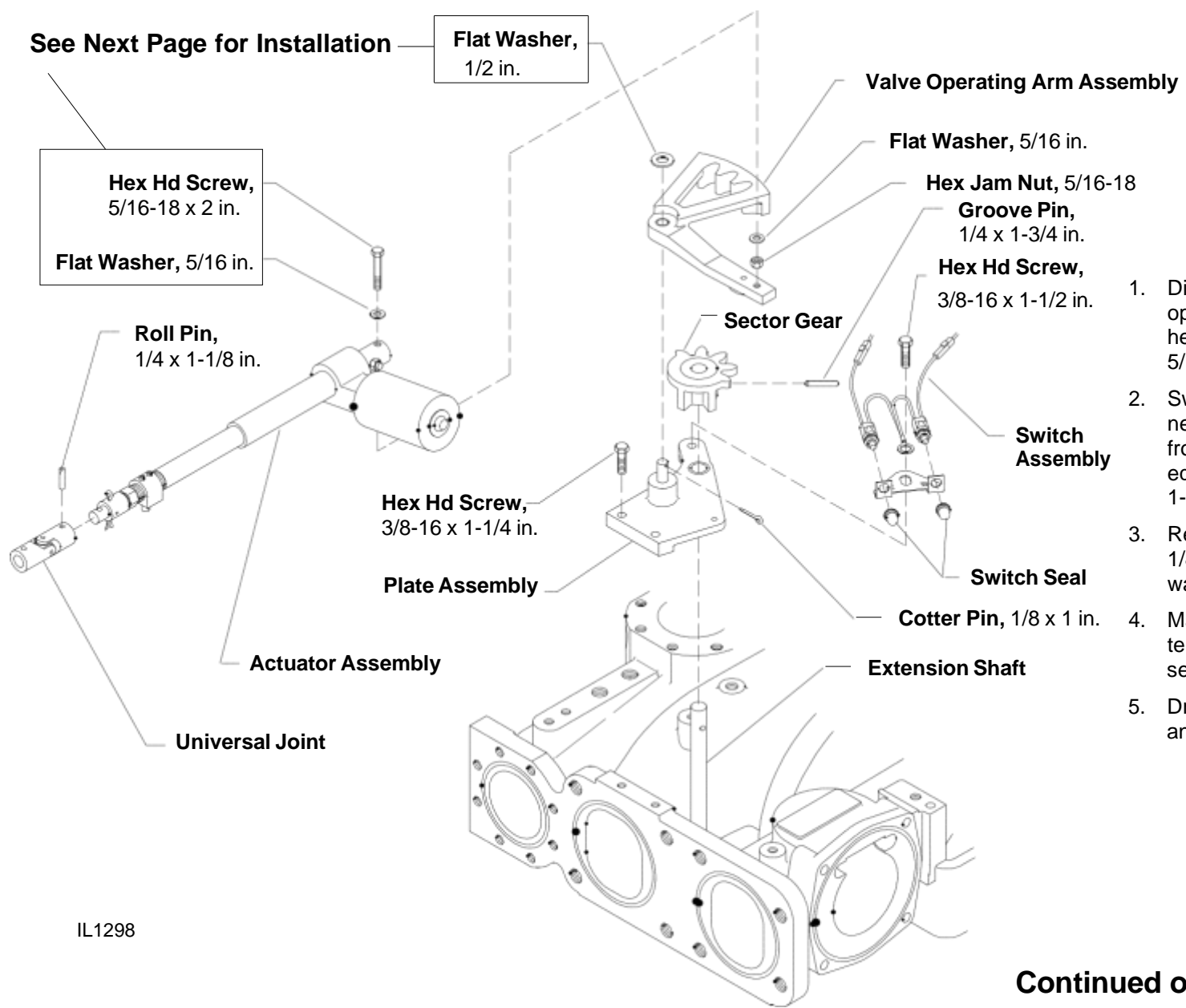

1. Disconnect actuator assembly from operating arm by removing 5/16-18 hex jam nut, 2 flat washers and 5/16-18 x 2 in. hex hd screw.
2. Swing aside the actuator. It may be necessary to remove the override from the end of the actuator, (if so equipped) by removing the 1/4 x 1-1/8 in roll pin and universal joint.
3. Remove operating arm by removing 1/8 x 1 in. cotter pin and 1/2 in. flat washer.
4. Mark the sector gear and end of extension shaft to aid in proper reassembly.
5. Drive out 1/4 x 1-3/4 in. groove pin and remove sector gear.

IL1298

Continued on Next Page

## Reciprocating Actuator Installation, Top Mounted Electric Actuator (Prior to 2000) - Continued

1. Install Grade 5 hex hd screw and washers in actuator as shown.
2. Thread jam nut onto hex hd screw. **Do not tighten.** Thread only as far as needed to provide 1/32 in. clearance between brass washer and actuator.
3. Thread hex hd screw into valve operating arm up to jam nut. Tighten jam nut against valve operating arm.
4. Check for actuator free play. If actuator does not pivot freely on hex hd screw, remove and provide more clearance between brass washer and actuator by adjusting jam nut. Repeat steps 3 & 4.
5. Connect motor to power supply.
6. Connect Manual Override, if required.

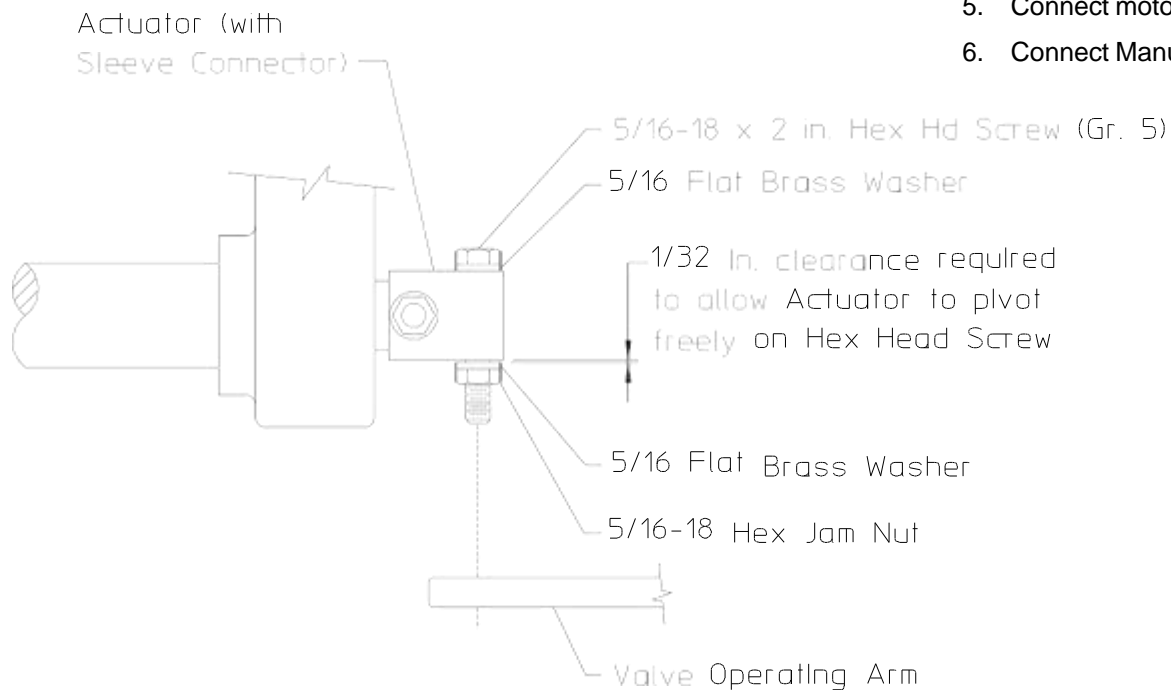

IL2137

## Transfer Valve Removal / Installation for Reciprocating Actuator (Prior to 2000)

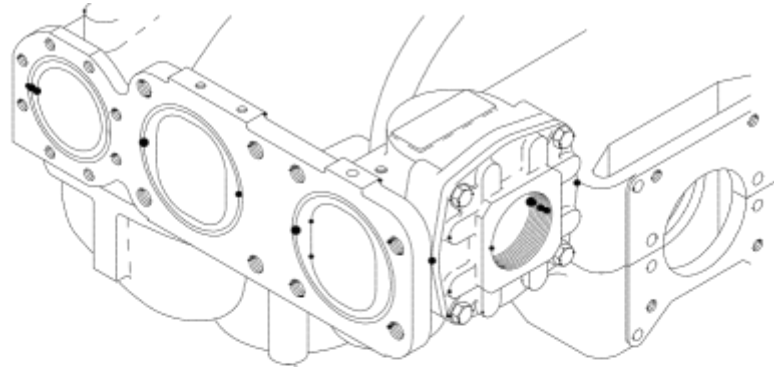

**NOTE:** The transfer valve only needs to be removed and disassembled if it needs to be repaired.

There is a repair kit available for replacing the seals in the transfer valve.

1. Remove the three 1/2-13 x 1 in. hex head screws that attach the transfer valve cover to the pump body. Do not remove the four 5/16-18 x 3/4 in. socket head screws.
2. Use the two jacking screw holes to remove the transfer valve from the pump body.

See page 49 for correct orientation of sector gear and arm.

See page 50 for connecting top mounted actuator to valve operating arm.

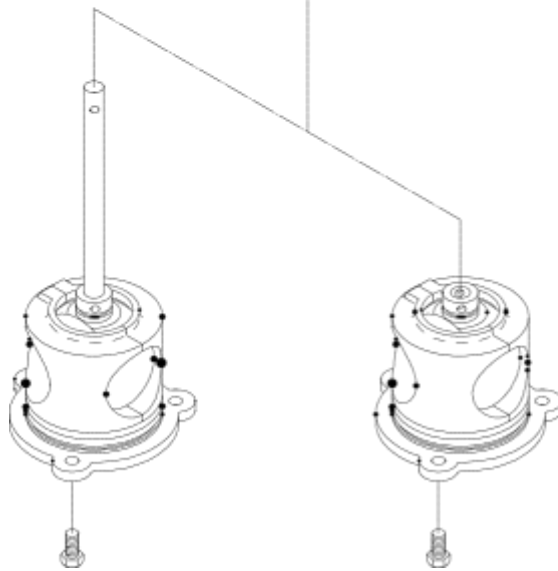

**Top Mounted  
Transfer Valve**

**Bottom Mounted  
Transfer Valve**

IL1294

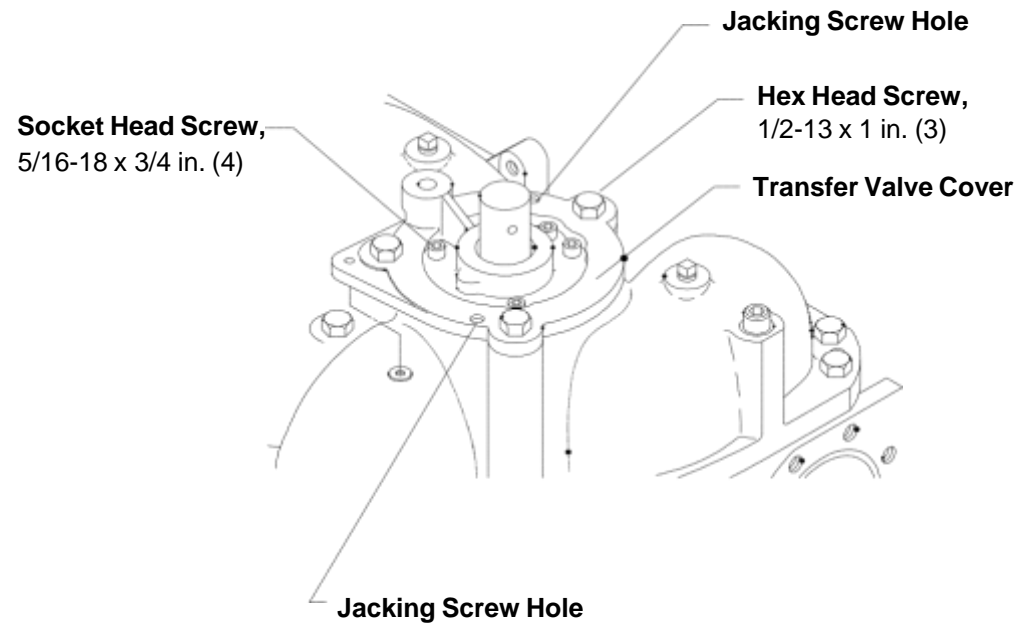

# Transfer Valve Removal / Installation for Reciprocating Actuators (Prior to 2000)

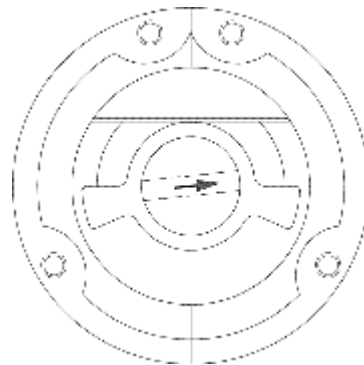

**NOTE:** Locate transfer valve ball stops in position shown.

**Top View of Assembled Transfer Valve**

IL1240

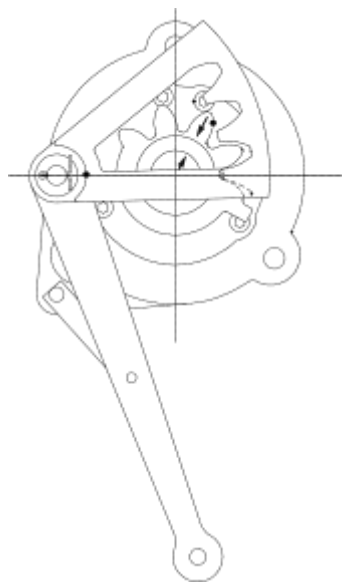

**Manual Transfer Valve**

IL1241

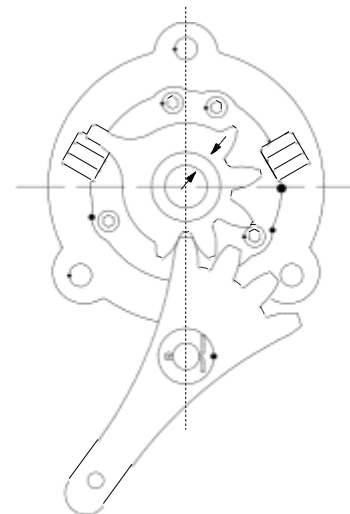

**Electric Transfer Valve**

IL1242

## Transfer Valve Repair for Reciprocating Actuator (Prior to 2000)

**NOTE:** The transfer valve only needs to be removed and disassembled if it needs to be repaired or updated.

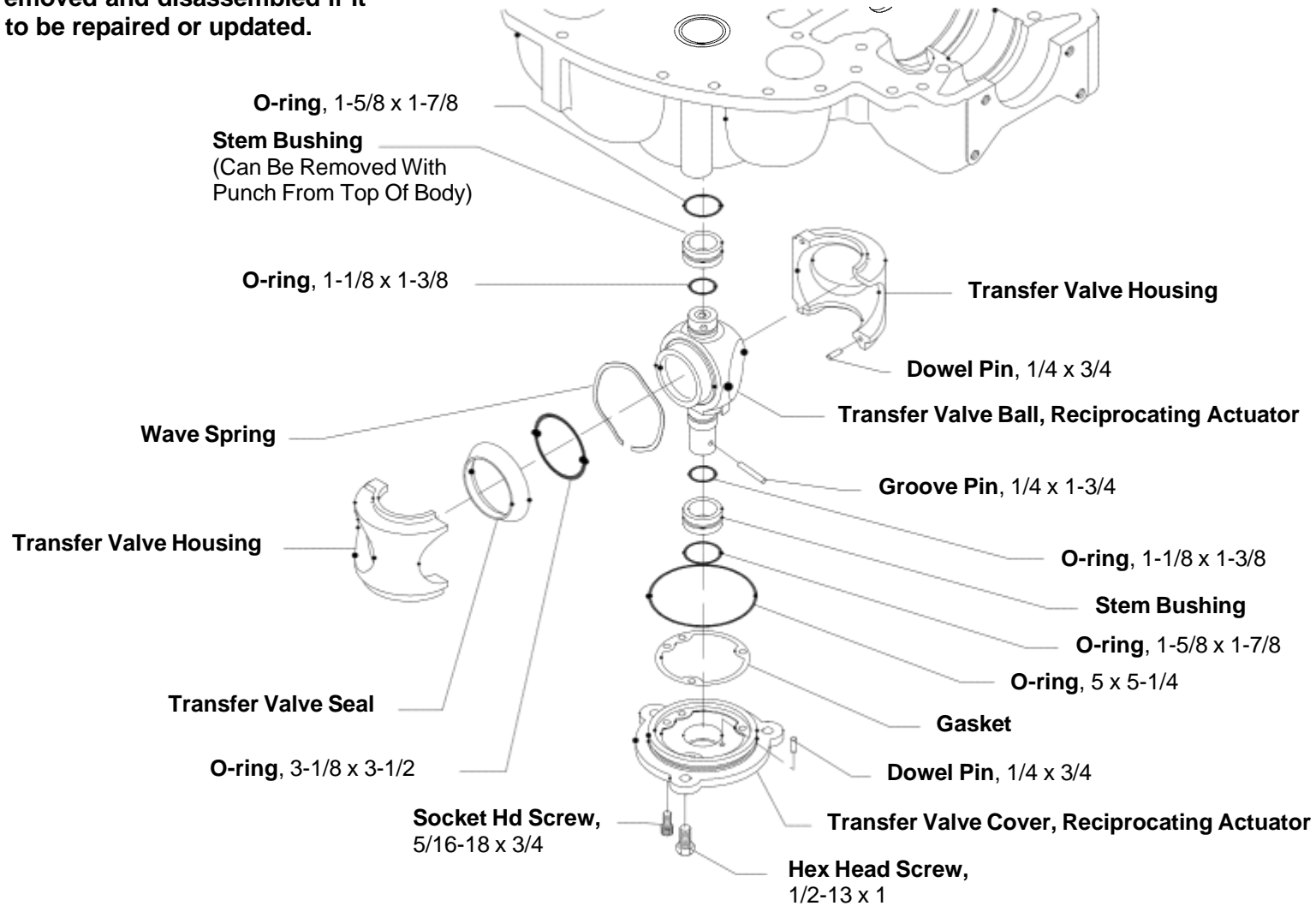

IL1244