

CP3-500 Body and Impeller Shaft Assembly

Overhaul Instructions

Form No.	Section	Issue Date	Rev. Date
F-1031	4215	04/28/95	01/03/07

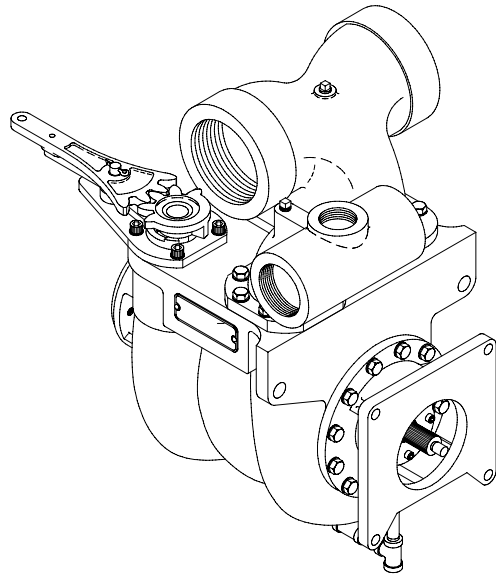

WATEROUS
Fire Pumps – Since 1886



Table of Contents

- Introduction 1
- General Overhaul Information** 1
 - Tools and Equipment 1
 - Preliminary Testing 1
 - Cleaning 1
 - Pump Bodies and Impellers 1
 - Bearings, Gaskets, Seals and O-rings 1
 - Impeller Shafts 1
 - Installing Ball Bearings 1
- Disassembling Transmission from Pump 2
- Disassembling Intake and Discharge Adapters 3
- Disassembling Mechanical Seal Piping 4
- Transfer Valve 5
- Mechanical Seal Removal from Transmission End 6
- Disassembling Inboard Head 7
- Disassembling Outboard Bearing 8
- Bearing Puller 9
- Mechanical Seal Removal from Outboard End 10
- Disassembling Outboard Head and Impeller 11
- Impeller and Wear Rng Repair Dimensions 12
- Interstage Seal Removal 13
- Reassembling Outboard head and Impeller 14
- Mechanical Seal Assembly on Outboard End 15
- Reassembling Outboard Bearing 16
- Bearing Assembly Tool 17
- Reassembling Inboard Head and Impeller 18
- Mechanical Seal Assembly on Transmission End 19
- Reassembling Pump and Transmission 21

Illustrations

- 1. Disassembling Transmission from Pump 2
- 2. Disassembling Intake and Discharge Adapters 3
- 3. Disassembling Mechanical Seal Piping 4
- 4. Transfer Valve 5
- 5. Mechanical Seal Removal from Transmission End 6
- 6. Disassembling Inboard Head 7
- 7. Disassembling Outboard Bearing 8
- 8. Bearing Puller 9
- 9. Mechanical Seal Removal from Outboard End 10
- 10. Disassembling Outboard head and Impeller 11
- 11. Installing Undersize Wear Rings 12
- 12. Interstage Seal Removal 13
- 13. Reassembling Outboard Head and Impeller 14
- 14. Mechanical Seal Assembly on Outboard End 15
- 15. Reassembling Outboard Bearing 16
- 16. Bearing Assembly Tool 17
- 17. Reassembling Inboard Head and Impeller 18
- 18. Mechanical Seal Assembly on Transmission End 19
- 19. Reassembling Pump and Transmission 21

Introduction

This instruction contains the information needed to overhaul and repair Waterous CR series centrifugal fire pumps.

The text uses reference numbers when discussing specific parts. These numbers refer to the parts called out on the Service Parts List which is supplied with the pump.

General Overhaul Information

Tools and Equipment

The following tools and equipment are needed to overhaul a pump:

1. Usual automotive mechanic's hand tools.
2. An arbor press for assembling or disassembling components.
3. An engine lathe for turning impeller hubs.
4. A suitable hoist and slings.
5. Torque capability up to 325 lb-ft.

While no special tools and equipment are required, a few special items are illustrated or described so the mechanic can make them or they are available from the apparatus manufacturer or the Waterous Company. These special items are not absolutely necessary, but they will make the mechanic's work much easier.

Preliminary Testing

Before disassembling a pump, test it thoroughly, if possible, and record the results. A comparison of this test with periodic tests recommended in form F-1031, Section 1000 can often reveal specific pump troubles. Excessive speed, for instance, indicates that impellers and/or wear rings are probably worn.

Cleaning

The continued satisfactory operation of a pump depends to a great extent upon the cleanliness of its internal parts. Sand, dirt or other abrasive material will wear bearings, gears and related parts. Before disassembling a pump for repairs, be sure to clean its exterior. Make sure the working space, benches and tools are clean. Use only clean, lint-free cloths to wipe off components. Before reassembling a pump or its components, be sure to clean them thoroughly.

Pump Bodies and Impellers

Flush out these components and related parts with clean water. Use a stiff brush to remove loose scale, caked sediment, etc. Be sure to remove all

traces of old gaskets. Examine pump bodies, covers, adapters and fittings for cracks, severe corrosion or other damage. Almost all damage to these parts results from improper use or maintenance, or from freezing. Replace defective parts.

Bearings, Gaskets, Seals and O-rings

Parts of this nature are frequently damaged during removal or disassembly. In addition, they sometimes deteriorate or lose their effectiveness because of age or misuse. Replacing these parts whenever overhauling a pump is a good policy.

Impeller Shafts

Examine shaft for severe scratches, grooves or corrosion - especially under packing or mechanical seals. If scratches are not severe, and are not under packing and seals, clean them with a fine-cut file. Grooves are usually permissible if they are not sharp or too deep. Even slight longitudinal scratches will cause leaks and should be removed.

Installing Ball Bearings

Most Waterous pumps are designed so that ball bearings fit tightly on their shafts and have relatively loose fits in the bearing housings. When mounting these bearings on shafts, always apply force to the inner races. When bearings have a tight fit in the housings, and a heavy force is necessary to install them, be sure to apply force only to the outer bearing races. For either type of fit, applying force to the wrong bearing race may damage the balls and race.

6. Position the impeller shaft assembly in a vertical position in an arbor press with the spline end of the shaft up and the impeller end of the outer race of bearing (S15) supported by the table of the press. Press the shaft (S9) out of the bearings (S13 & S11), spacer (S12) and oil seal sleeve (S14).

Disassembling Transmission from Pump

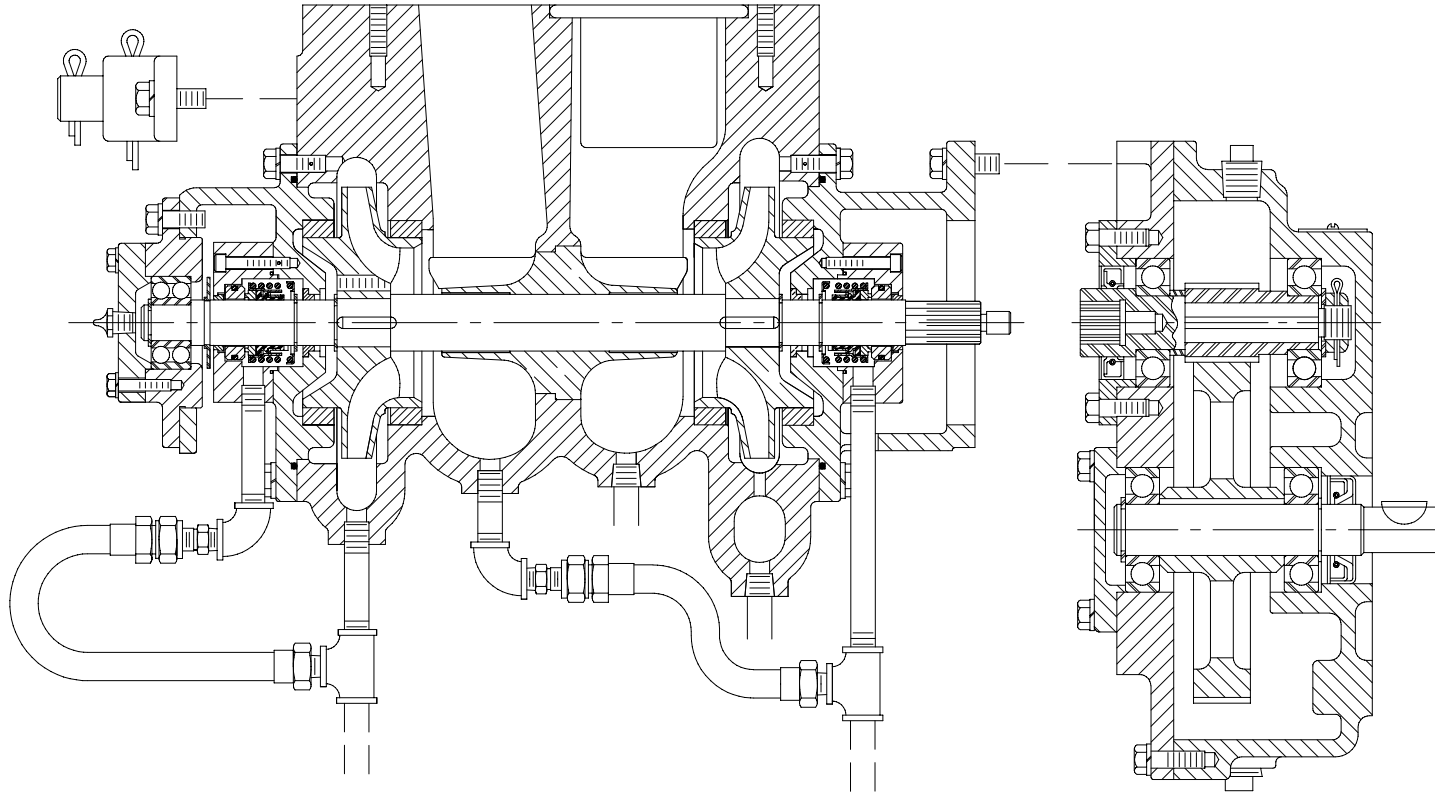

IL1331

7. Remove the four cap screws and lock washers that attach the transmission to the head assembly.
8. Pull transmission straight back from head.
9. Remove suspension bracket from pump body.

Disassembling Intake and Discharge Adapters

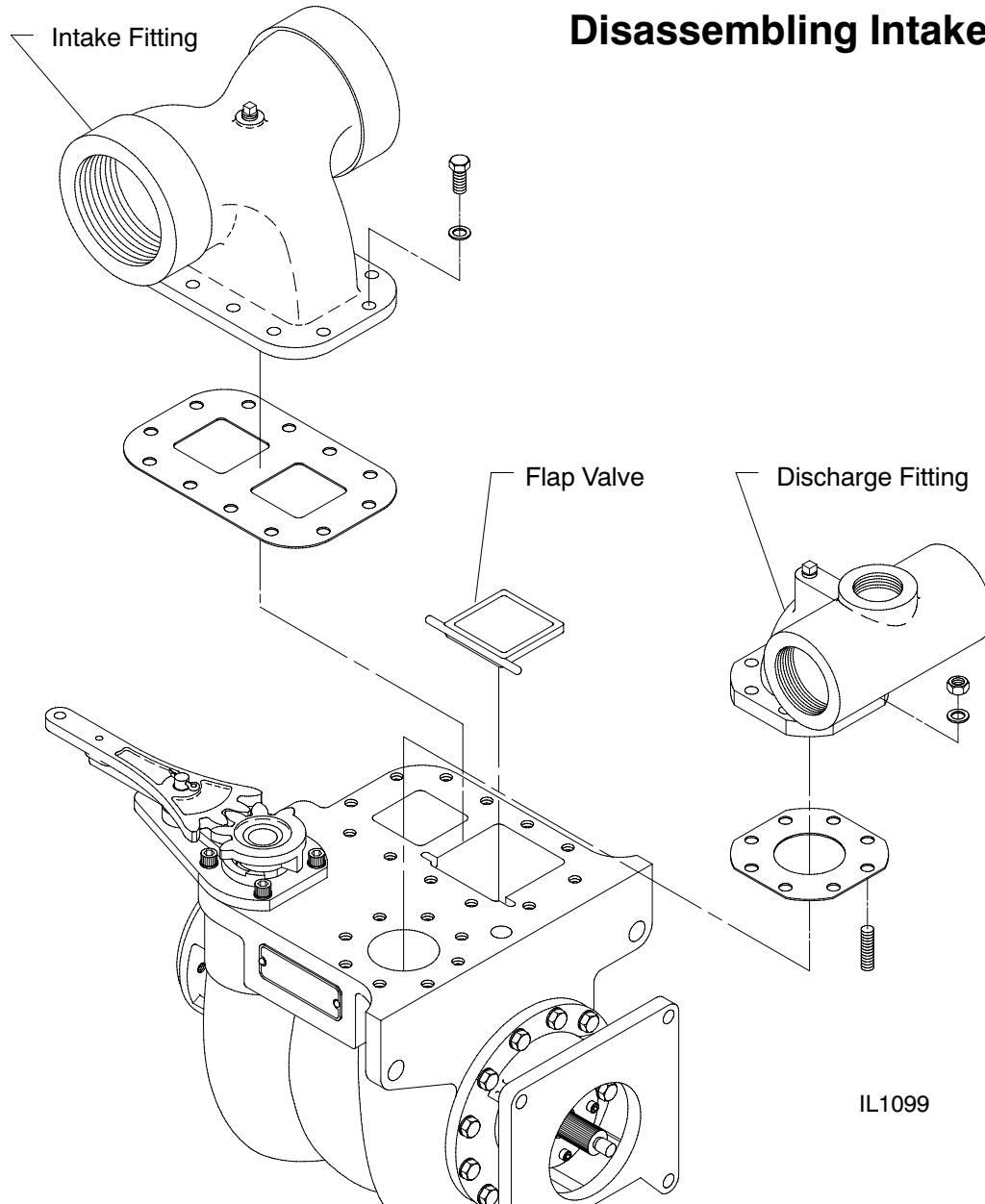

1. Remove the hex hd screws and nuts that attach the intake and discharge fittings to the pump body.
2. Remove the fittings and the gaskets.
3. Remove the flap valve and check for damage or corrosion.

Disassembling Mechanical Seal Piping

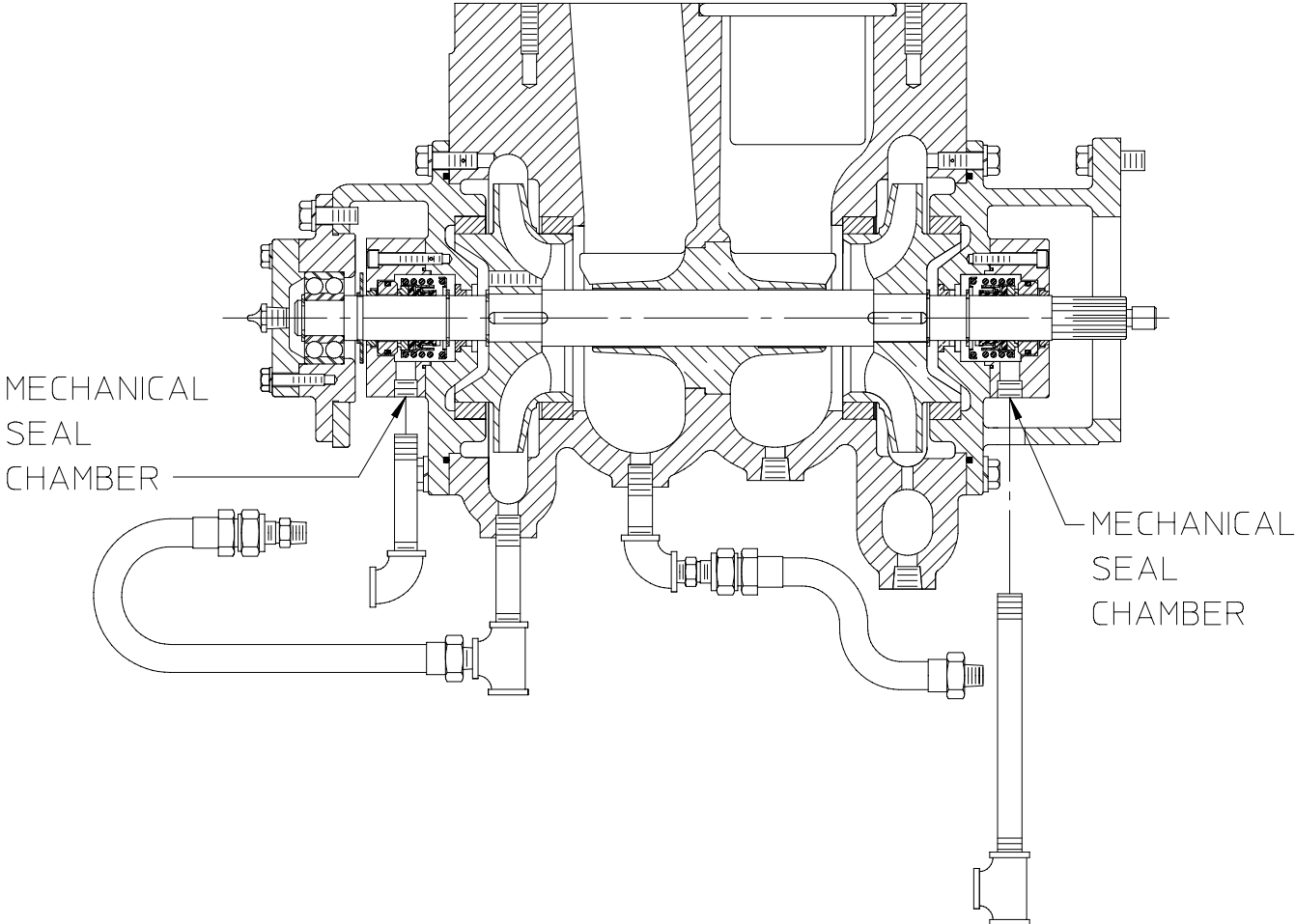

1354

Transfer Valve

Note: The transfer valve only needs to be removed and disassembled if it needs to be repaired.

Before disassembling transfer valve make sure the arrows are still visible on the transfer valve stem and sector gear. If the arrows are worn off, mark the stem and sector gear so they line up correctly during reassembly.

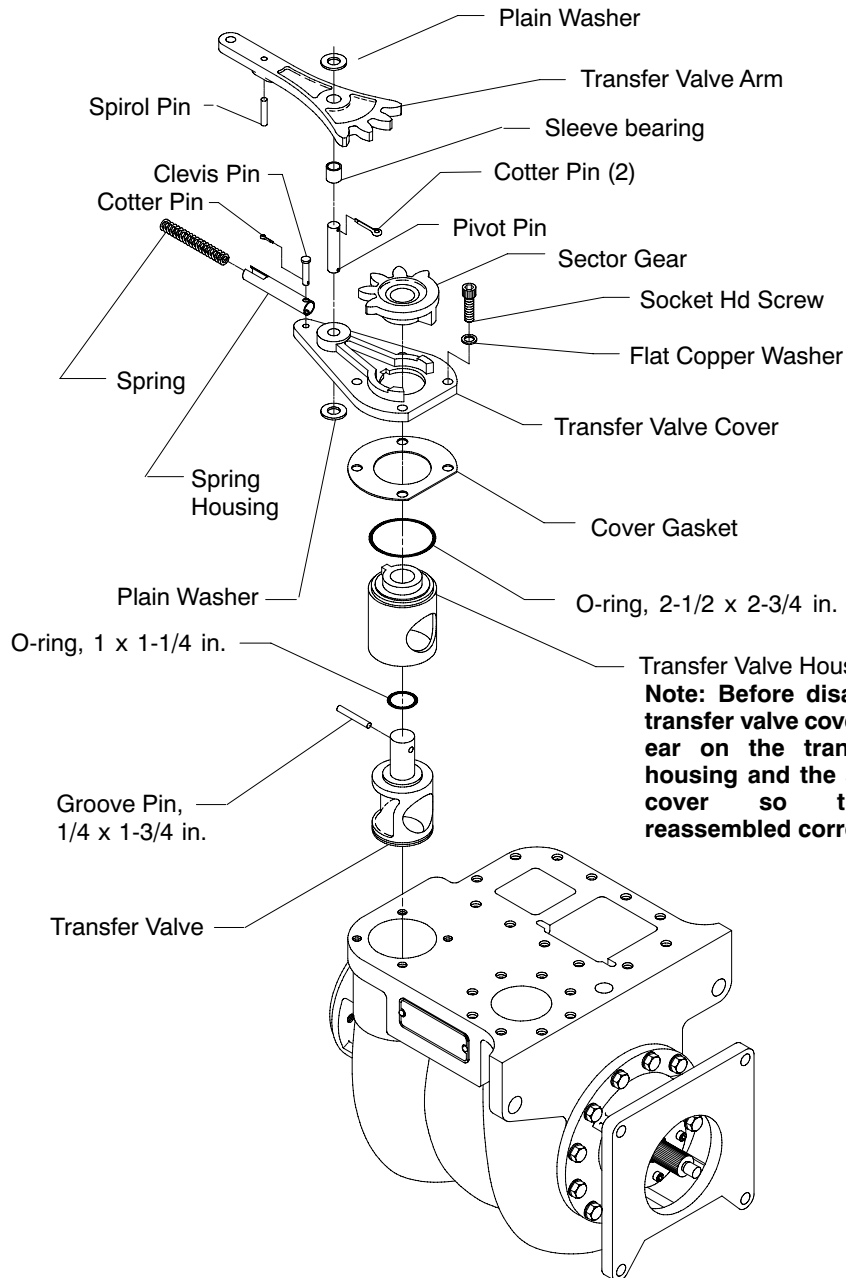

Note: Before disassembling transfer valve cover, mark the ear on the transfer valve housing and the slot on the cover so they are reassembled correctly.

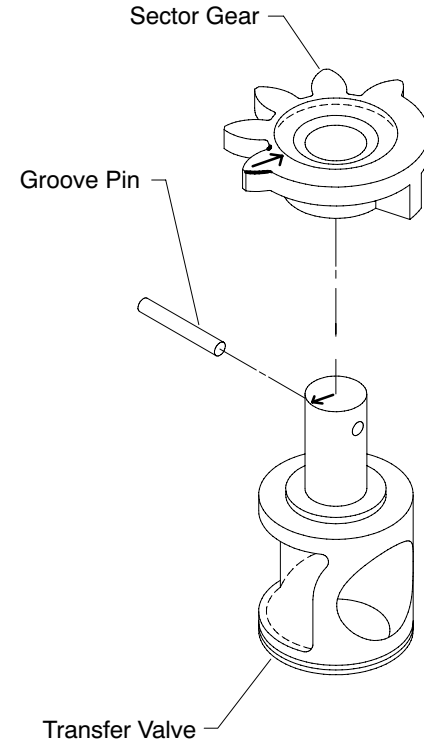

Note: Make sure the arrows on the sector gear and transfer valve line up and the groove pin is perpendicular to the arrow when the transfer valve is reassembled.

Mechanical Seal Removal from Transmission End

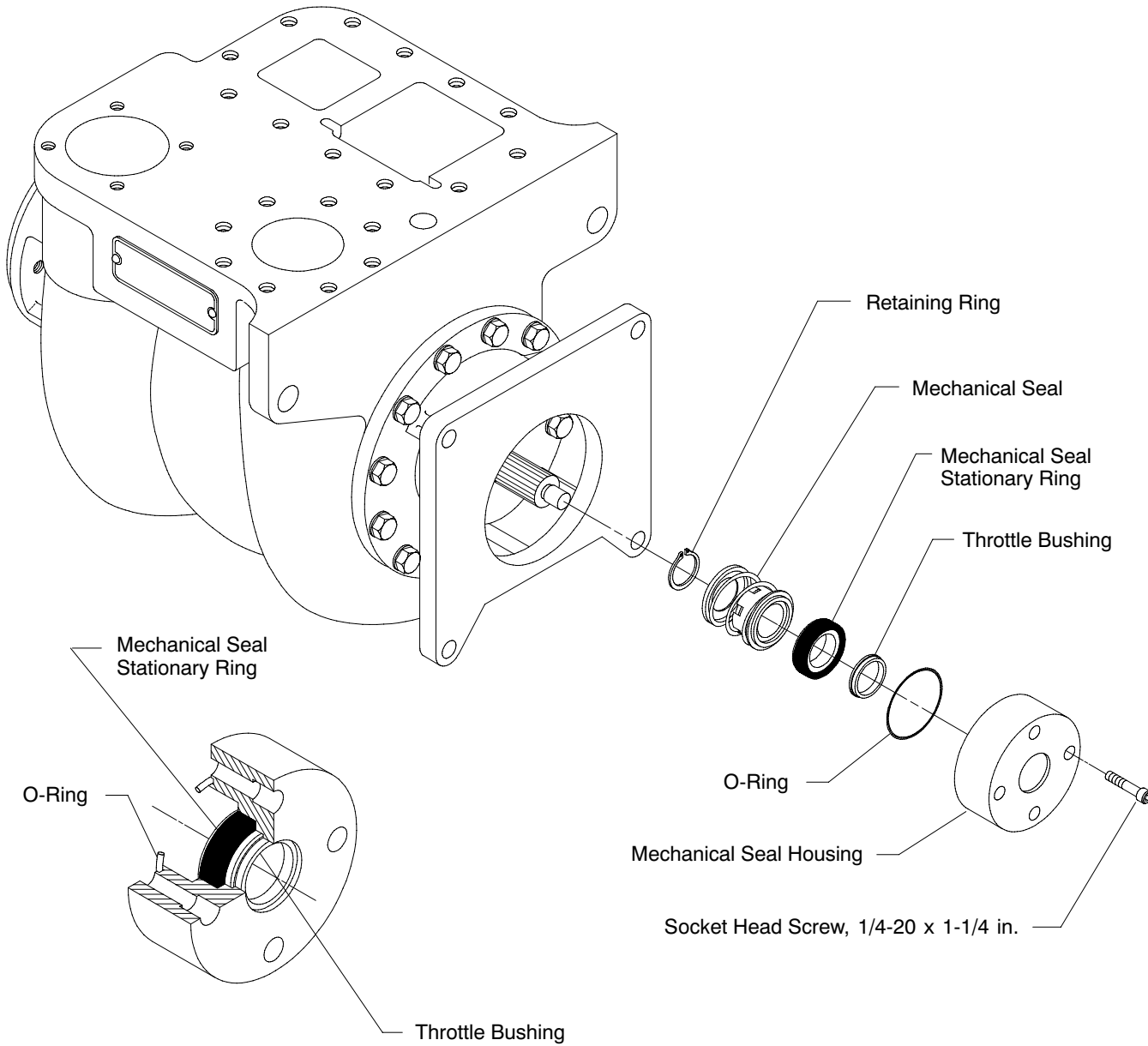

1. Remove the four socket head screws that attach the mechanical seal housing.
2. Remove the mechanical seal housing.
3. Remove the mechanical seal
4. Remove retaining ring from behind mechanical seal.
5. Push out throttle bushing to remove mechanical seal stationary ring.

1105, 1117

Disassembling Inboard Head

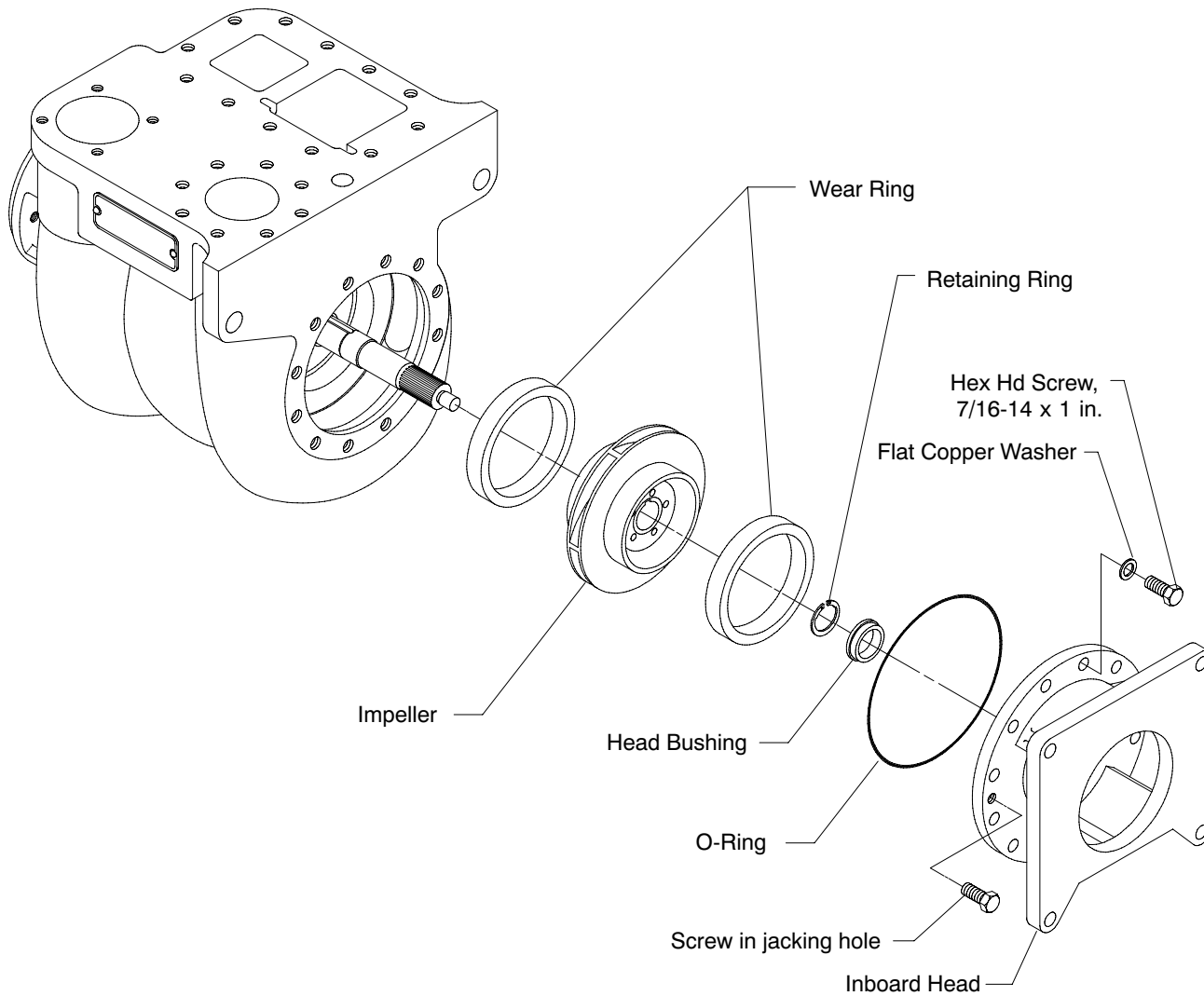

1. Remove the 12 hex hd screws and washers that attach inboard head to body.
2. Use jacking screws to remove inboard head.
3. Remove O-ring.
4. Check the head bushing and replace if worn. The original inside diameter of this bushing is 1.084/1.085.
5. Remove retaining ring.
6. Remove impeller and check wear rings, remove only if worn. See page 11 for wear ring repair dimensions.

Note: The impeller is a press fit on the shaft.

IL1106

Disassembling Outboard Bearing

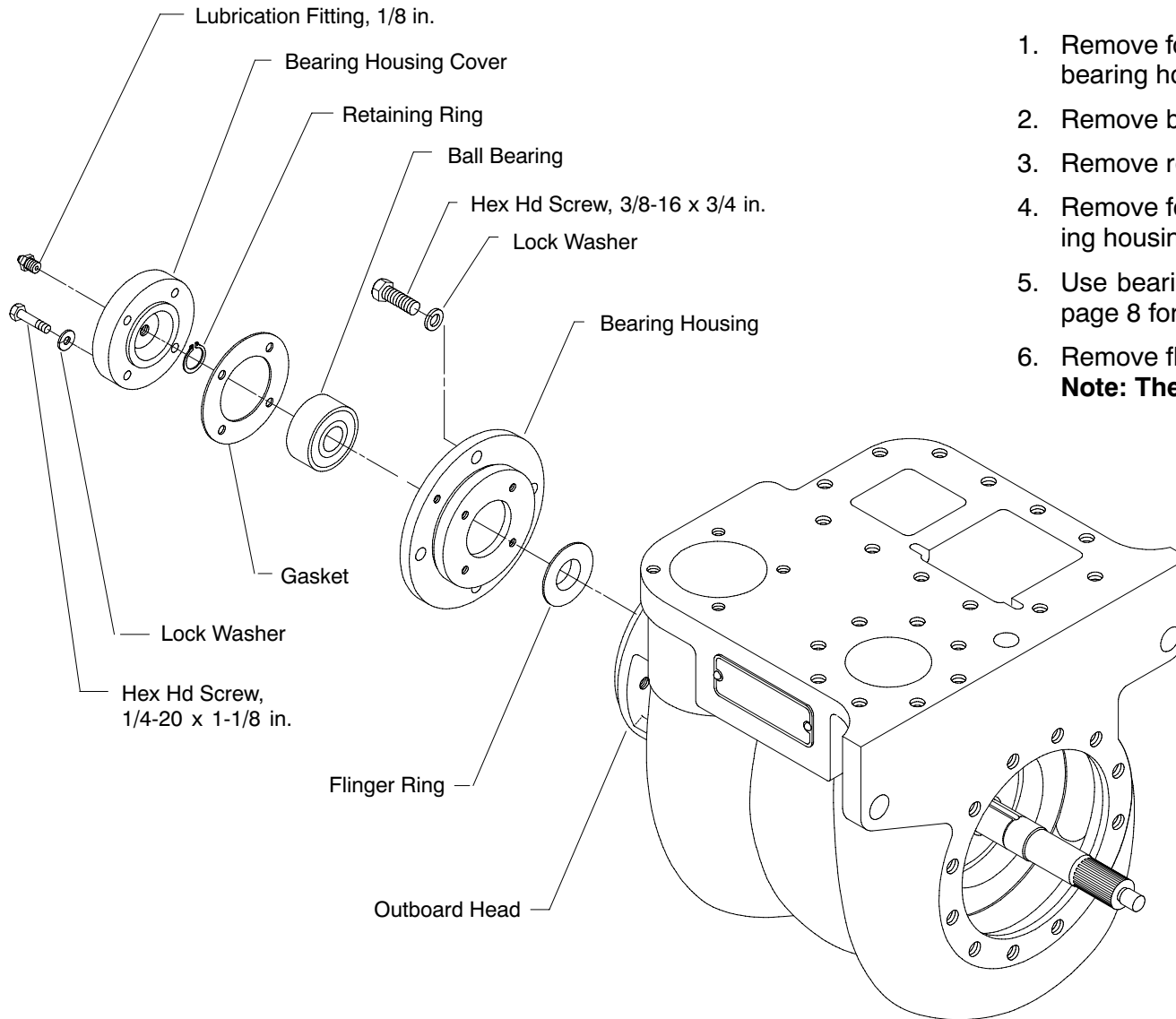

1. Remove four hex hd screws and lock washers that attach bearing housing cover to bearing housing
2. Remove bearing housing cover and gasket.
3. Remove retaining ring.
4. Remove four screws and lock washers that attach bearing housing to outboard head.
5. Use bearing puller to remove bearing from shaft. (See page 8 for bearing puller.)
6. Remove flinger ring.
Note: The flinger ring is on the shaft with a press fit.

IL1107

Bearing Puller

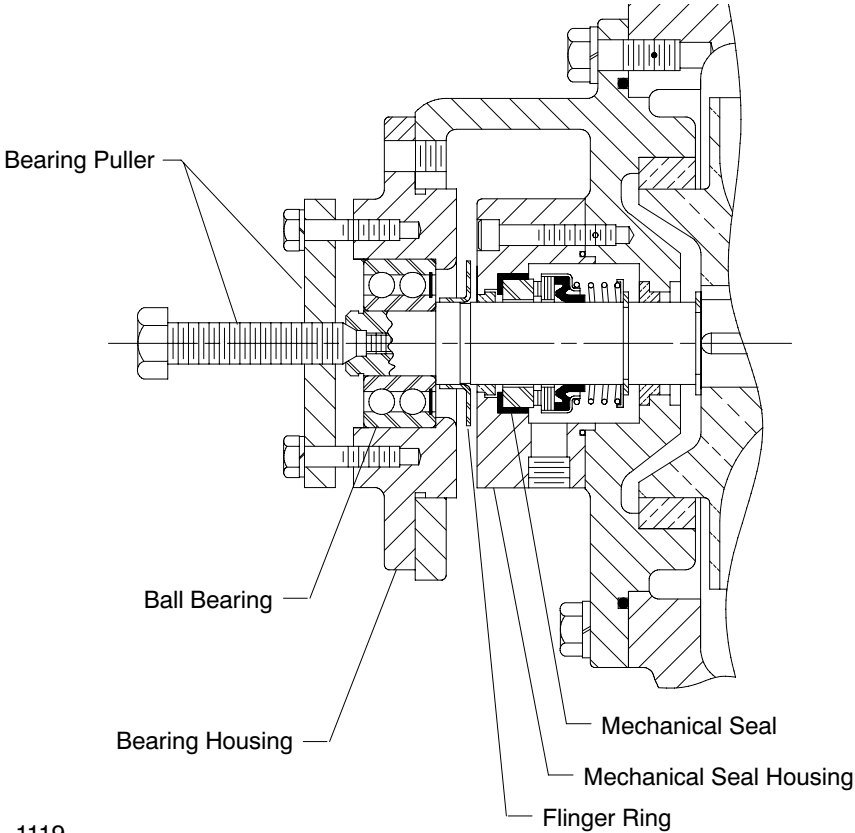

1119

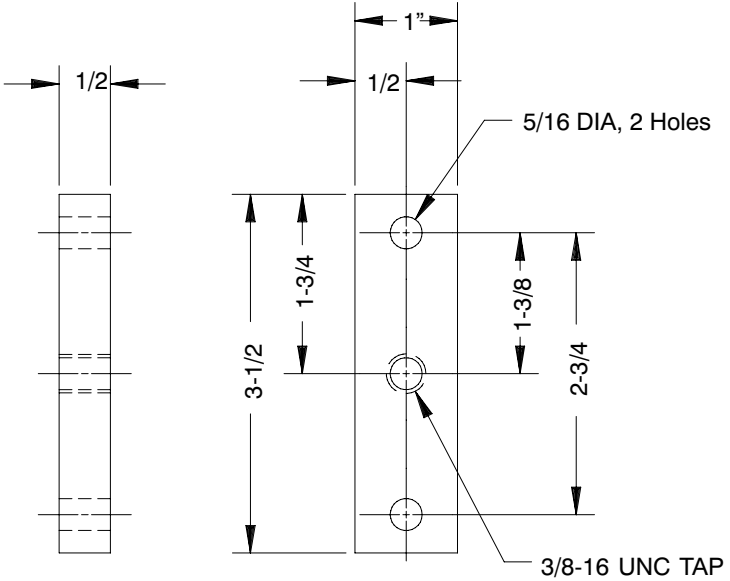
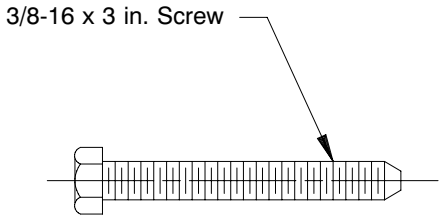

1121

Mechanical Seal Removal from Outboard End

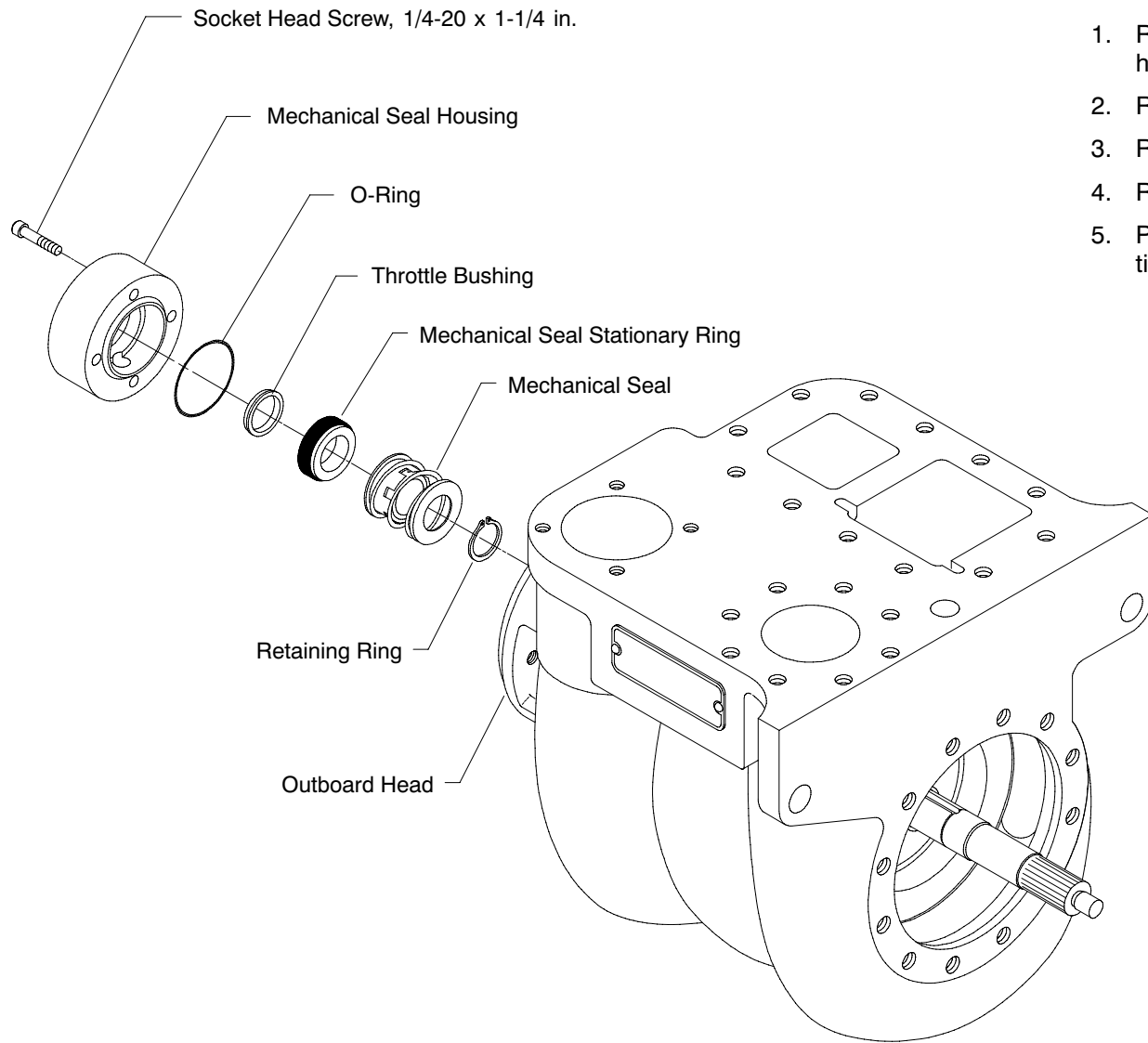

1. Remove socket head screws that attach mechanical seal housing to outboard head.
2. Remove mechanical seal housing.
3. Remove mechanical seal.
4. Remove retaining ring from behind mechanical seal.
5. Push out throttle bushing to remove mechanical seal stationary ring.

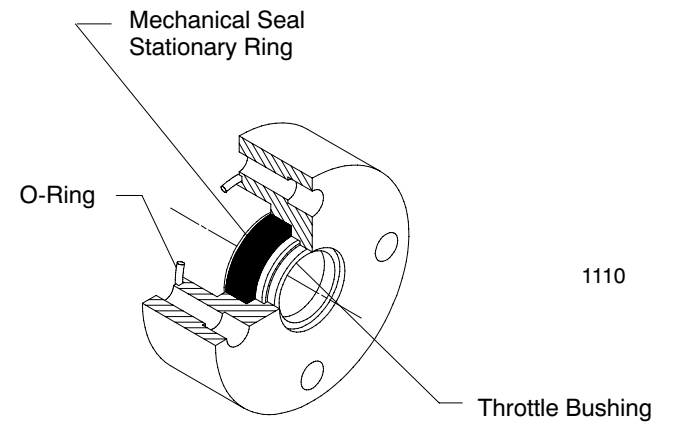

1110

Disassembling Outboard Head and Impeller

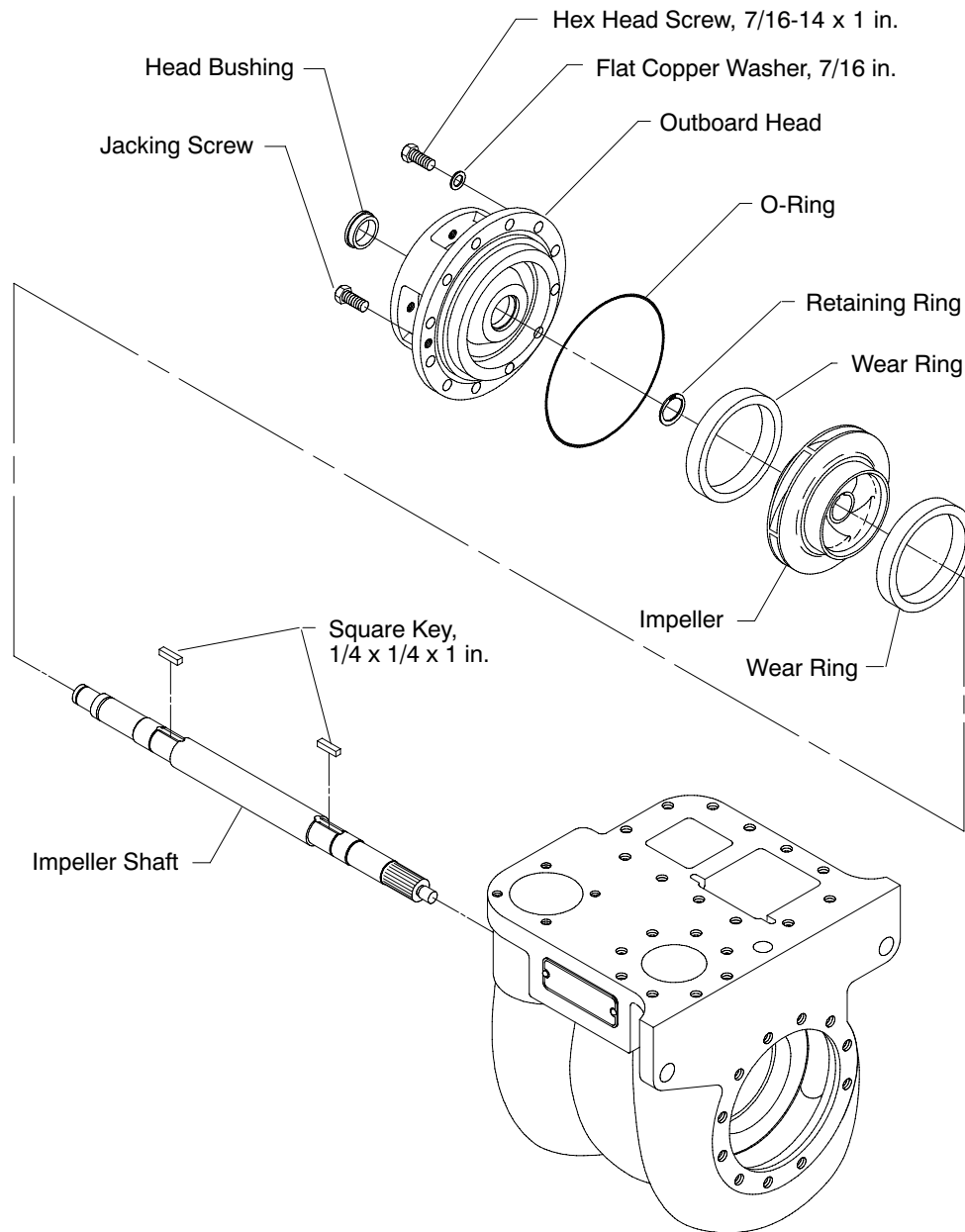

1. Remove the 12 hex hd screws and washers that attach inboard head to body.
 2. Use jacking screws to remove inboard head.
 3. Remove O-ring.
 4. Check the head bushing and replace if worn. The original inside diameter of the bushing is 1.084/1.085.
 5. Remove retaining ring.
 6. Remove impeller and check wear rings, remove only if worn. See page 11 for wear ring repair dimensions.
- Note: The impeller is a press fit on the shaft.**

Impeller and Wear Ring Repair Dimensions

Impeller Number	Original Hub Dia	Factory Clearance	Maximum Clearance*	Original Wear Ring Number	Reworked Hub Dia A	New Wear Ring Number
70966-1 70967-1	3.748/3.747	0.013/0.010	0.0195	61363	3.723/3.721 3.698/3.696 3.673/3.671	61363-25 61363-50 61363-75
72244-1 72245-1	2.875/2.874	0.013/0.010	0.0195	61436	2.850/2.848 2.825/2.823 2.800/2.798	61436-25 61436-50 61436-75

*This is the suggested maximum wear ring clearance before reworking or replacing the impeller and wear rings.

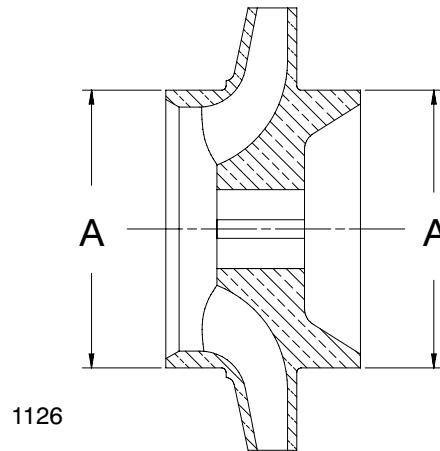

Installing Undersize Wear Rings

1. Check wear rings and impeller hubs for deep grooves or scratches.
 2. If inspections shows that the wear ring clearances are excessive (diametral clearance in excess of .019), or if the impeller hubs are scored or grooved, use the dimension in the table above to rework the hubs.
 3. The diametral clearance is determined by averaging the results of four measurements taken at 90° increments.
 4. Repair rings are available 0.025, 0.050 or 0.075 inches undersize. The table gives the original hub dimension for each impeller and the rework dimensions for each degree of undersize.
- If pump uses “L” shaped wear rings (61436), install them with the wide machined face of the rings away from the impellers.**

Interstage Seal Removal

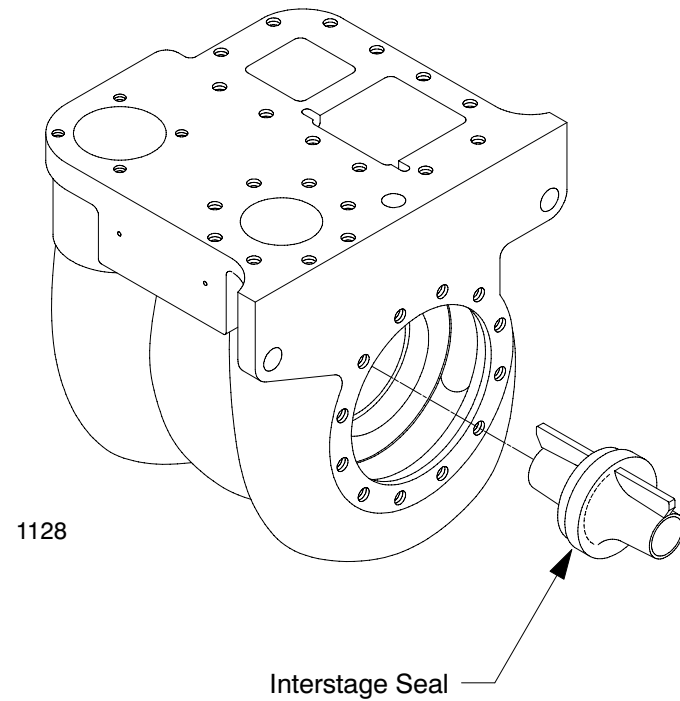
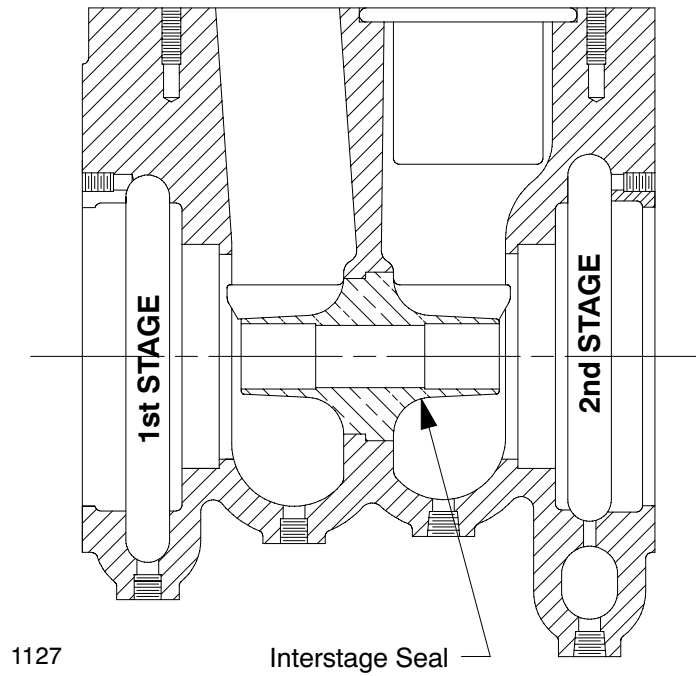

The interstage seal seldom needs to be replaced. If the total clearance between the interstage seal and the impeller shaft is much greater than 0.030 inches, replacing the seal may be desirable.

The interstage seal can only be removed from the second stage end using a press.

Reassembling Outboard Head and Impeller

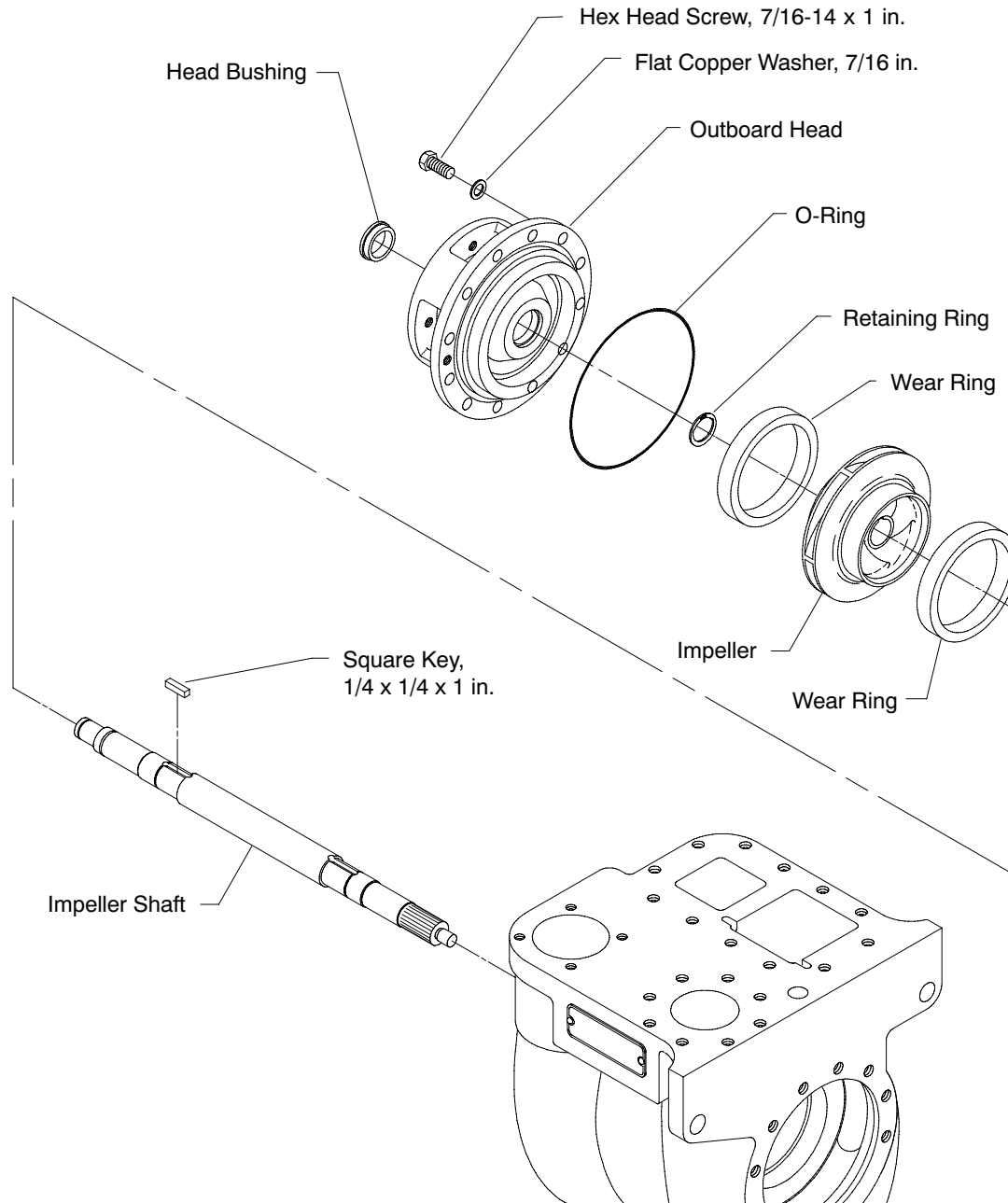

1. Replace the wear rings in the outboard head and pump body.
2. Replace the key on the outboard end of the shaft.
3. Press the impeller on the shaft with the eye opening facing in.
4. Install retaining ring.
5. Install impeller and shaft in the pump body.
6. Install head bushing in the outboard head.
7. Place O-ring in groove of outboard head, holding it in place with grease.
8. Assemble outboard head to pump body using twelve copper washers and hex head screws.

Mechanical Seal Assembly on Outboard End

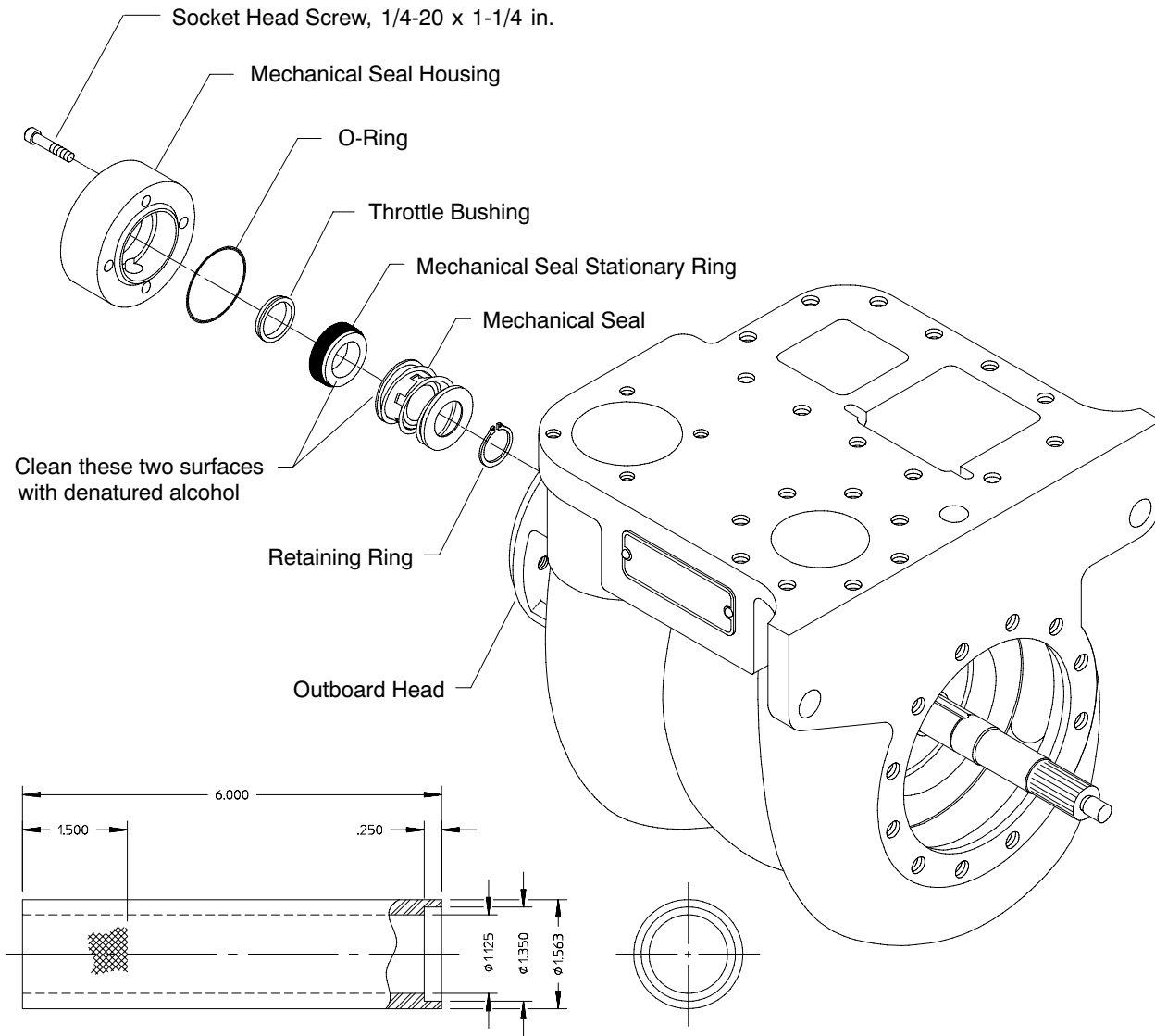

MECHANICAL SEAL INSTALLATION TOOL

CAUTION

The mechanical seal primary and stationary rings are made of brittle material. The material can be cracked or chipped. Extra care must be taken when handling these rings.

Note: If Waterous Mechanical Seal Lubricant part no. 52608 is not available, P80 rubber lubricant, straight dish soap or glycerin may be substituted.

1. Replace retaining ring.
2. Install mechanical seal on shaft using mechanical seal lubricant.
3. Replace throttle bushing and mechanical seal stationary ring in the mechanical seal housing.
4. Replace O-ring on the mechanical seal housing.
5. Clean face of mechanical seal and stationary ring with denatured alcohol.
6. Use the four socket head screws to install the mechanical seal housing on the outboard head with the hole for the piping facing down.

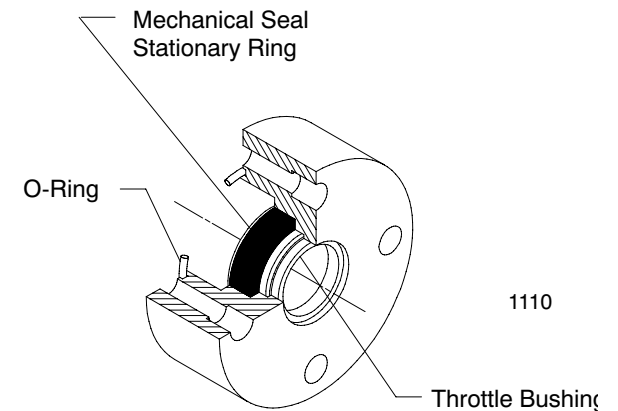

1110

Reassembling Outboard Bearing

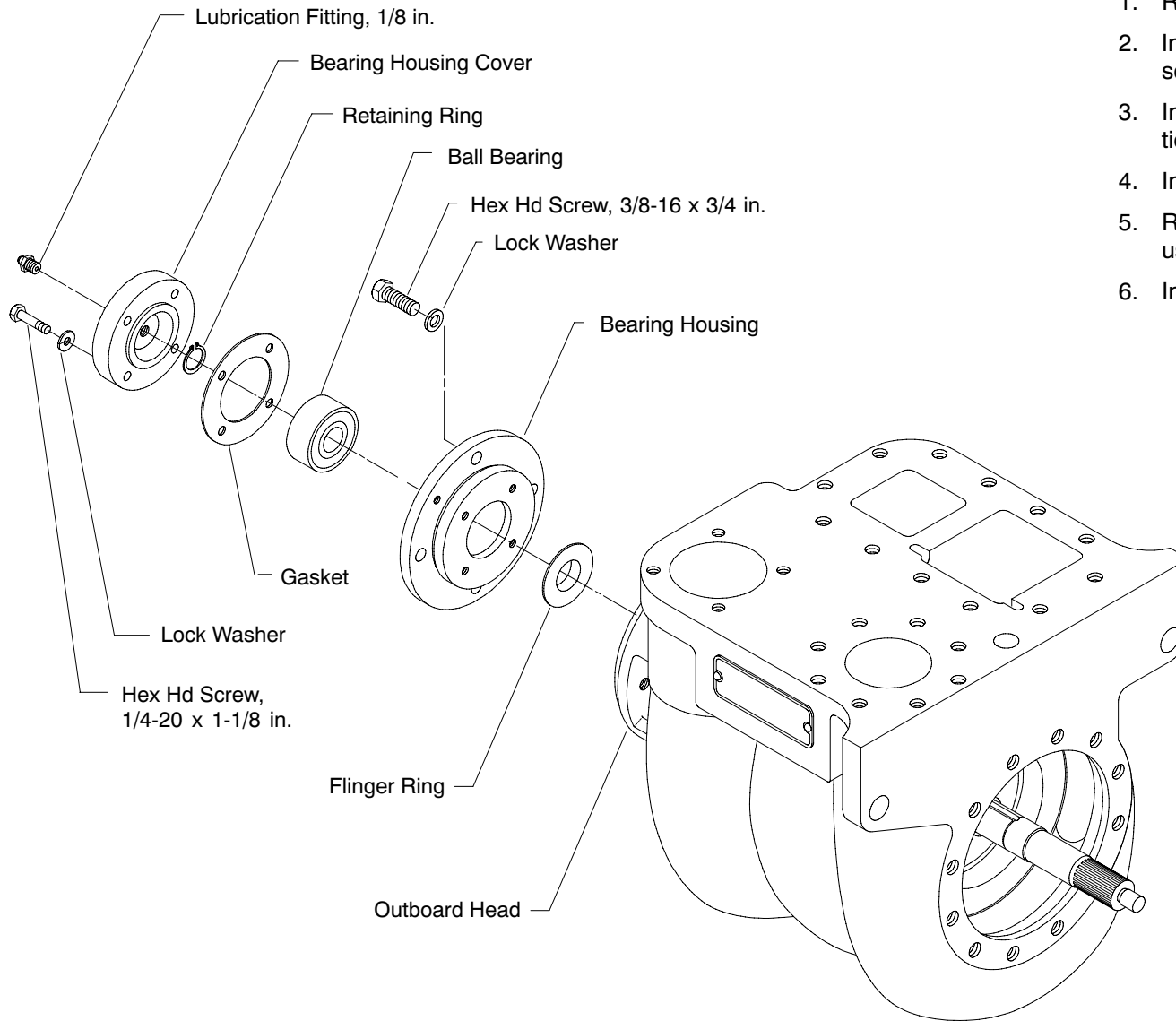

1. Replace flinger ring, large diameter in.
2. Install bearing housing using four lock washers and screws.
3. Install bearing, shield side in, using bearing installation tool shown on page 16.
4. Install retaining ring.
5. Replace cover gasket and install bearing housing using four hex head screws and lock washers.
6. Install lubrication fitting and grease bearing.

Bearing Assembly Tool

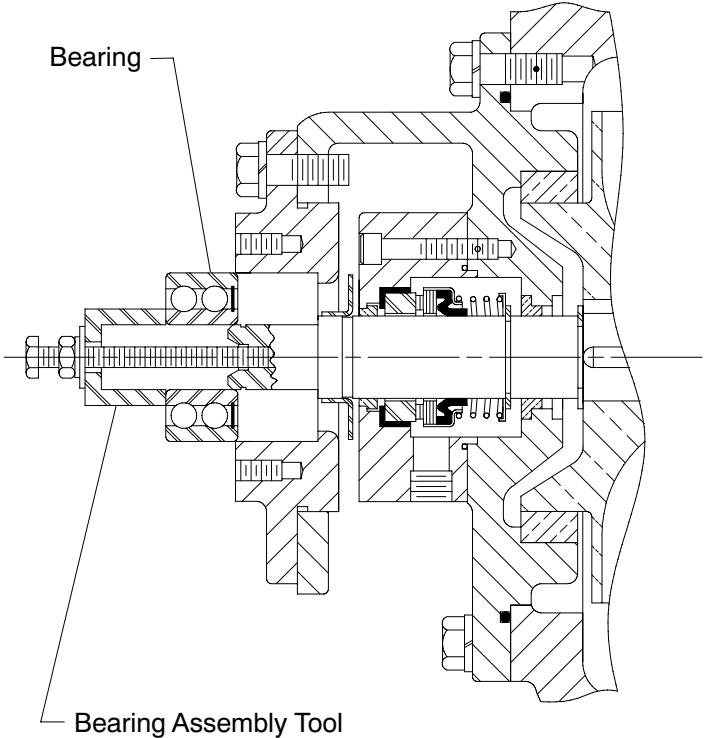

1120

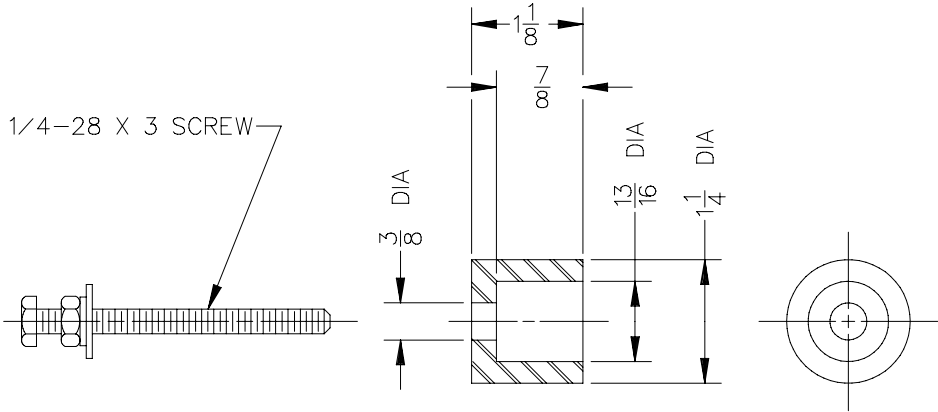

1146

Reassembling Inboard Head and Impeller

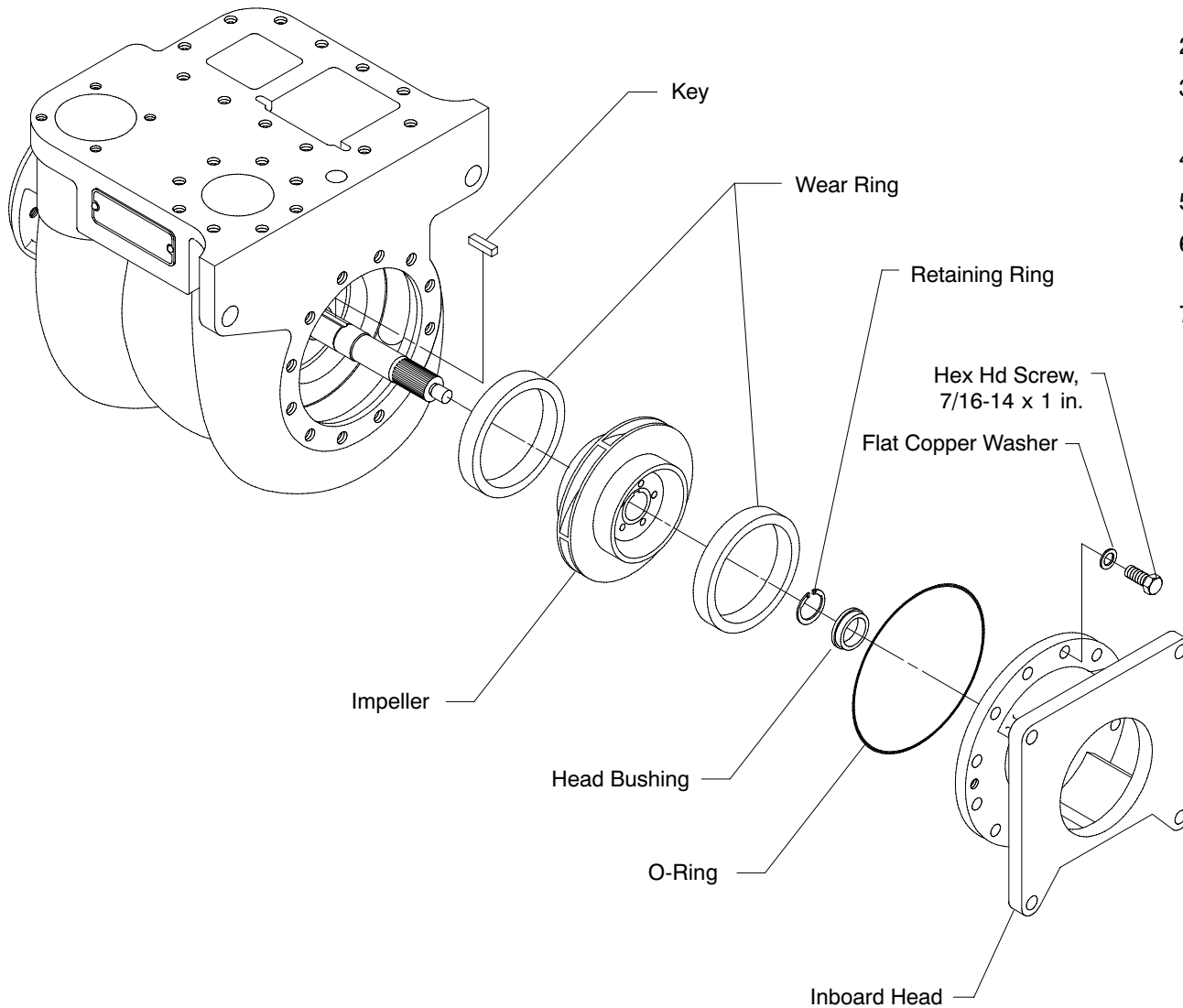

1. Replace the wear rings in the outboard head and pump body.
2. Replace the key on the impeller shaft.
3. Press impeller on the impeller shaft with eye opening facing in.
4. Install retaining ring.
5. Install head bushing.
6. Place O-ring in groove of inboard head, holding it in place with grease.
7. Assemble inboard head to pump body using twelve copper washers and hex head screws.

Mechanical Seal Assembly on Transmission End

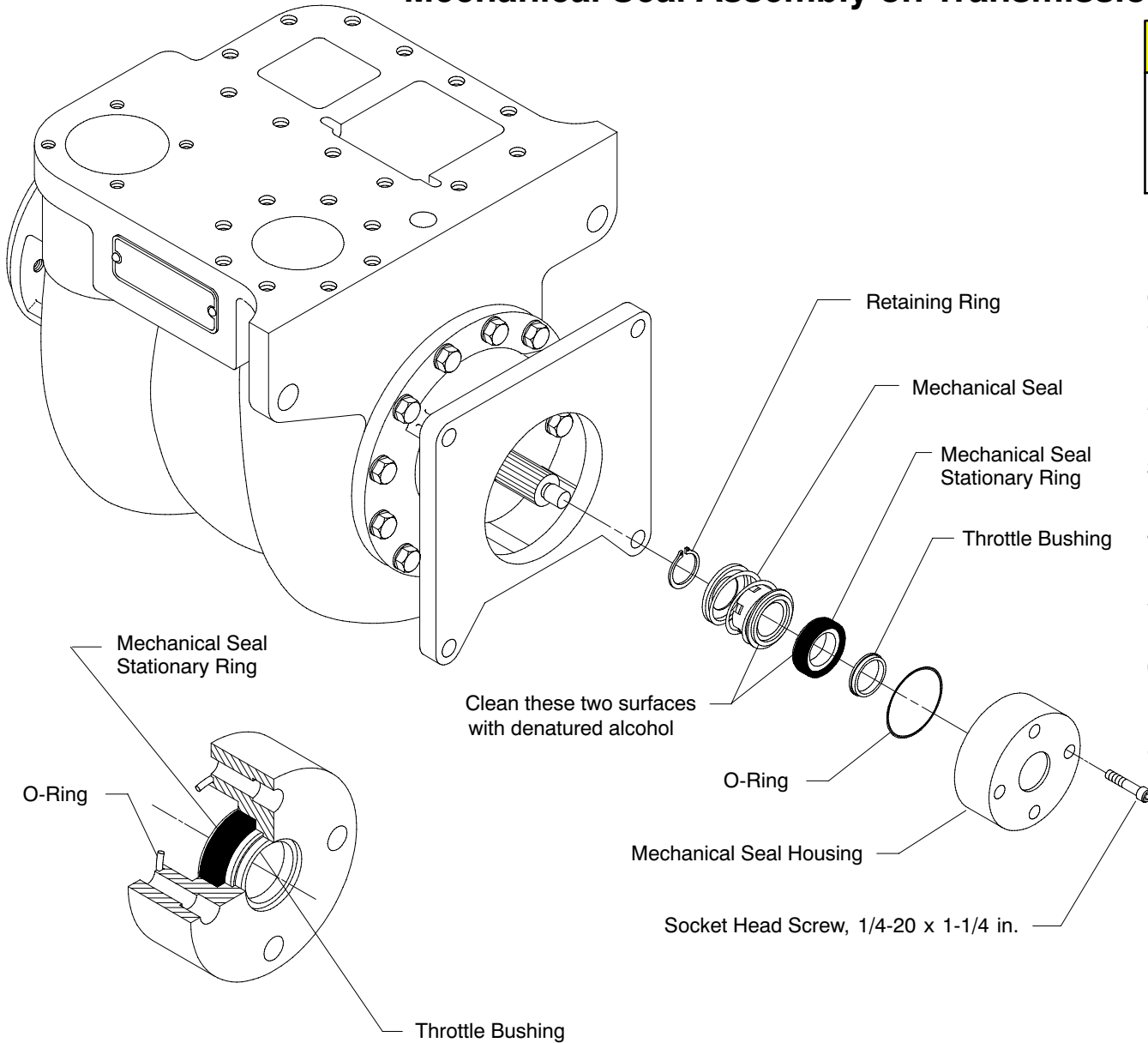

CAUTION

The mechanical seal mating ring is made of silicon carbide. The material is brittle and can be cracked or chipped. Extra care must be taken when handling the mating ring.

Note: If Waterous Mechanical Seal Lubricant part no. 52608 is not available, P80 rubber lubricant, straight dish soap or glycerin may be substituted.

1. Replace retaining ring.
2. Install mechanical seal on shaft using mechanical seal lubricant.
3. Replace throttle bushing and mechanical seal stationary ring in the mechanical seal housing.
4. Replace O-ring on the mechanical seal housing.
5. Clean face of mechanical seal and stationary ring with denatured alcohol.
6. Use the four socket head screws to install the mechanical seal housing on the inboard head with the hole for the piping facing down.
7. Rotate impeller shaft to make sure it runs freely.

1105, 1117

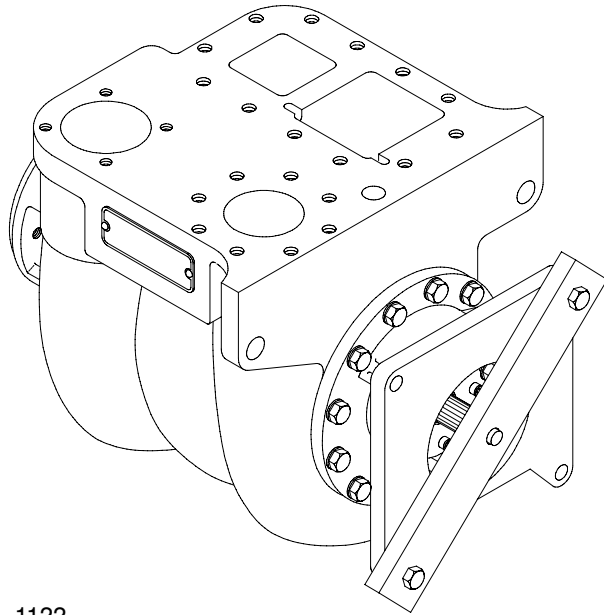

If the impeller shaft does not have a tapped hole on the outboard bearing end to use the bearing installation tool, the transmission end has to be assembled before the outboard bearing can be installed. Use the fixture shown below to hold the impeller shaft in place during bearing installation.

1122

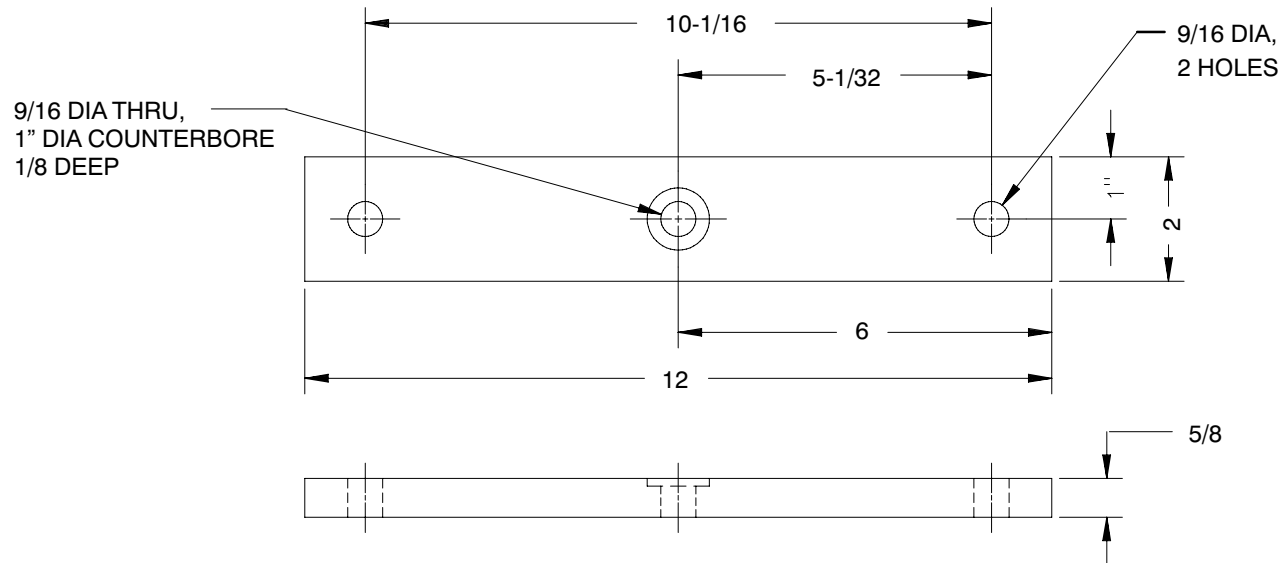

1123

Reassembling Pump and Transmission

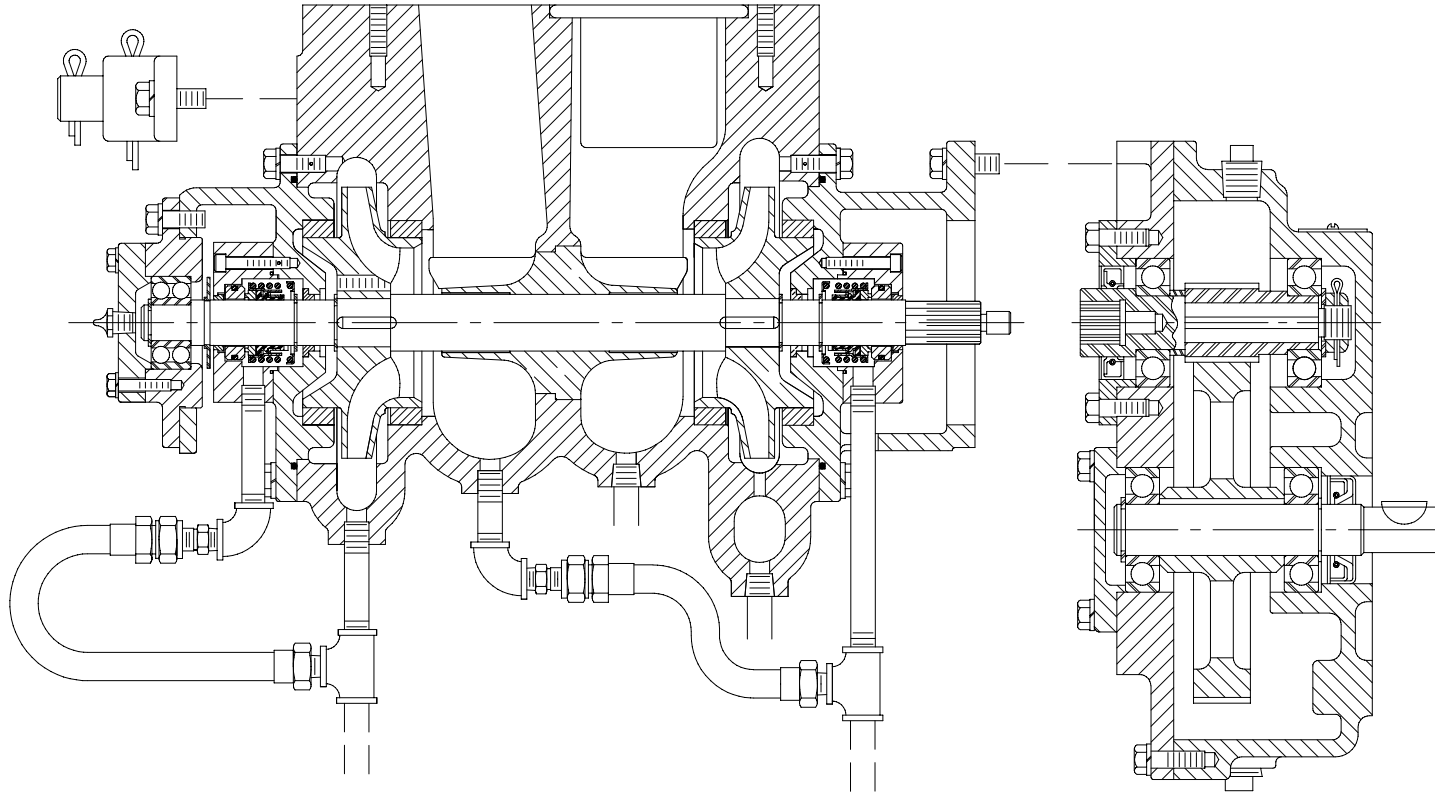

1331

1. Install the piping to the mechanical seal chambers.
2. Attach the transmission to the head assembly using the four cap screws and lock washers removed during disassembly.
3. Replace the suspension bracket on the pump body.