

# Overhaul Instructions

## S100 Series Centrifugal Fire Pumps

Form No.	Section	Issue Date	Rev. Date
F-1031	4219	02/22/02	1/19/18

### Table of Contents

Section	Page
Introduction	4
Ordering Repair Parts	4
Pump Models	5
General Overhaul Information	6
Disassembly	See Page 2
Reassembly	See Page 3

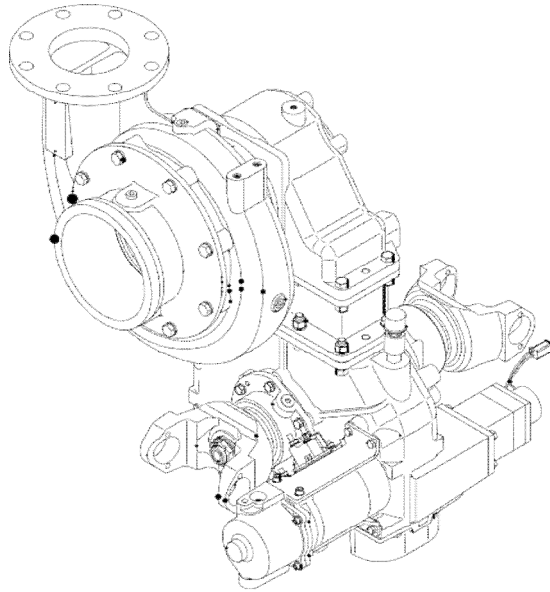

IL\_3292



# Table of Contents

## Disassembly

<b>Remove Pump and Transmission from Vehicle .....</b>	<b>7</b>
<b>Remove Pump Intake Fitting:</b>	
S100C10, S100C20 and S100PA Series Models (with End Suction Intake) .....	7
S101C20 Series Models (with Crosspipe Intake) .....	7
S100 Direct Drive Models (with End Suction Intake) .....	7
<b>Remove Impeller and Mechanical Seal:</b>	
S100C10, S100C20, S100PA Series Models (with End Suction Intake) and S101C20 Series Models (with Crosspipe Intake) .	8
S100D Direct Drive Models (with End Suction Intake) .....	8
<b>Remove Pump Body:</b>	
S100C10, S100C20, S100PA Series Models (with End Suction Intake) and S101C20 Series Models (with Crosspipe Intake) .	9
S100D Direct Drive Models (with End Suction Intake) .....	9
<b>Remove Seal Mating Ring and Oil Seal from Body.....</b>	<b>10</b>
<b>Remove Impeller Shaft from Bearing Housing.....</b>	<b>10</b>

**For Reassembly of the Pump, See the Index on the next page.**

# Reassembly

<b>Inspection and Repair</b> .....	<b>11</b>
<b>Reassembly Steps:</b>	
S100C10, S100C20, S100PA and S101C20 Series Models .....	12
S100D Direct Drive Models .....	12
<b>Install Impeller and Mechanical Seal</b> .....	<b>13</b>
Mechanical Seal Lubricant Application .....	13
<b>Install Intake Fittings:</b>	
S100C10, S100C20, S100PA and S100D Series Models .....	14
S101C20 Series Models .....	14
<b>Cross-Section Views:</b>	
S100C10, S100C20 and S100PA (with End Suction Intake) .....	15
S101C20 Series Models (with Crosspipe Intake) .....	15
S100D Direct Drive Models (with End Suction Intake) .....	16
<b>Final Assembly Steps</b> .....	<b>17</b>
<b>Lubrication</b> .....	<b>17</b>
<b>Testing:</b> .....	<b>17</b>
Hydrostatic .....	18
Operational .....	18

## Introduction

This instruction covers the overhaul of Waterous S100 Series single stage fire pumps. The S100 Series can be rated at 1250, 1500, 1750 or 2000 GPM.

Two different S100 models are available as follows:

Model	Intake	Discharge
S100	8 in. Victaulic® End Suction	4 in. ANSI Flange or 5 in. ANSI Flange
S101	Crosspipe which is mounted directly to chassis frame rails.	or Discharge Manifold

(See the next page for diagrams of pumps)

Your S100 Series pump may equipped with one of the following pump drives:

**C10 Series (prior to 09/01/09):** The C10 transmission is an aluminum, split-shaft, chain driven transmission that transmits power from the truck's transmission to either the fire pump or the drive axle of the truck.

**PA Series:** The PA transmission an aluminum chain drive transmission designed to be driven off the ten-bolt power take-off (PTO) provision available on the left side of the Allison MD or HD automatic transmission.

**C20 Series (after 09/01/09):** The C20 transmission is an aluminum, split-shaft, chain driven transmission that transmits power from the truck's transmission to either the fire pump or the drive axle of the truck.

**D Series:** Direct drive from a power take-off (PTO).

## Ordering Repair Parts

Refer to S100 Series Pump Body and Impeller Shaft Service Parts Lists furnished with our pump for identification of individual components. When ordering repair parts, furnish the reference number of the component (from Service Parts List) along with the Pump Model and Serial Number.

**Refer to the serial plate diagrams below for Model and Serial Number locations:**

### Serial Plate Located on Operator's Panel

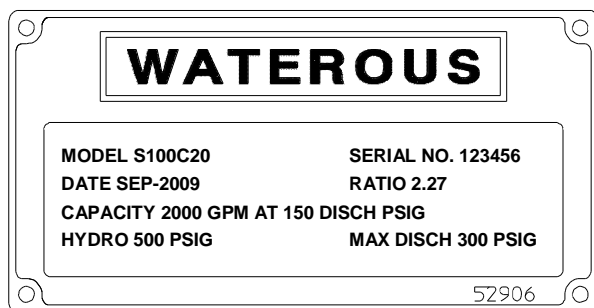

IL3270

### Serial Plate Located on Pump

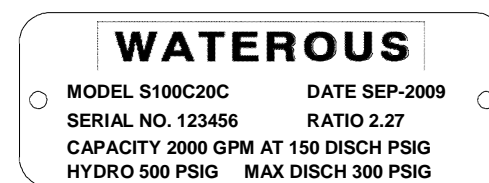

IL3269

## Pump Models

### S100C10 or S100C20 Series

End Suction Intake  
C10 or C20 Series Chain Drive Transmission

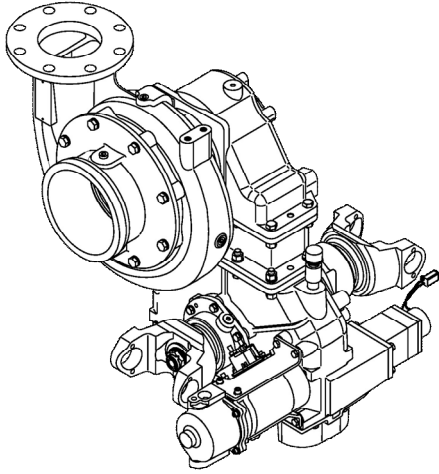

IL3292

### S100D Series

End Suction Intake  
Direct Drive

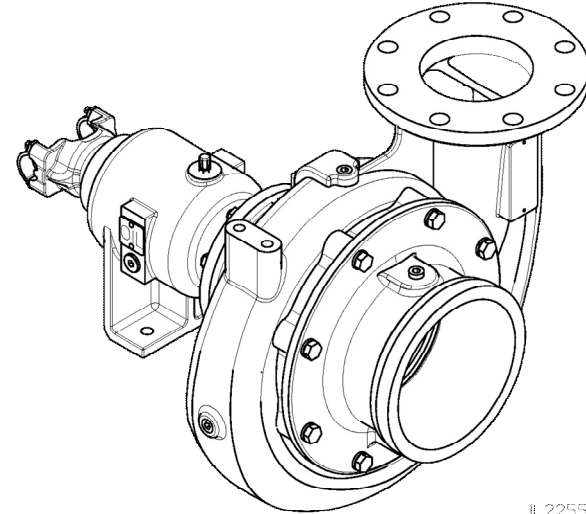

IL2255

### S100PA Series

End Suction Intake  
PA Series Chain Drive Transmission

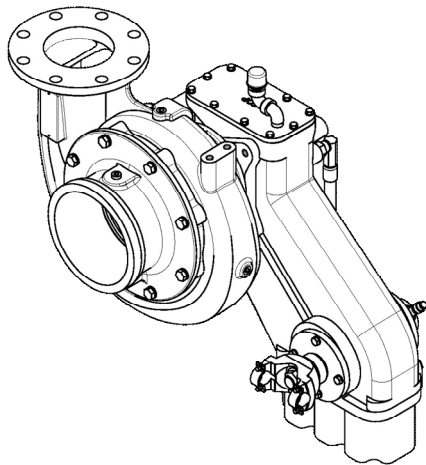

IL3294

### S101C20 Series

Crosspipe Intake  
C20 Series Chain Drive Transmission

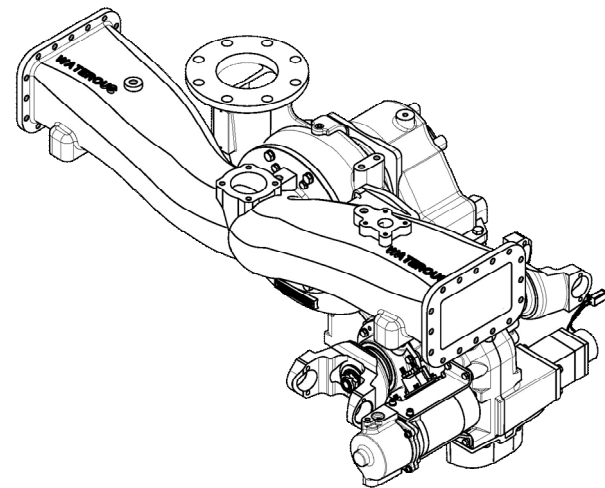

IL3293

## General Overhaul Information



### WARNING

#### **Pressure Hazard. May result in personal injury.**

Prior to connection or removal of hoses, caps or other closures with pump intake or pump discharge connections, relieve pressure by opening drains or bleeder valves. Bleeder valves should also be used while filling a hose connected to an intake with water.



### WARNING

#### **Rotating Parts Hazard or Unexpected Truck Movement. May result in serious personal injury or death.**

Stop the engine, set parking brake and chock the wheels before attempting to remove or repair the transmission.



### WARNING

#### **Pump Body / Transmission Temperature Hazard. May result in serious burns.**

The pump body / transmission may be warm from operation. Make sure that the pump body / transmission has cooled sufficiently prior to removal or repair.

### ***Tools and Equipment***

The following tools and equipment may be needed to overhaul a pump:

1. Usual automotive mechanic's hand tools.
2. An arbor press for assembling or disassembling components.
3. An engine lathe for turning impeller hubs.
4. A suitable hoist and slings.
5. Torque capability up to 325 lb-ft.

While no special tools and equipment are required, a few special items are illustrated or described so the mechanic can make them or they are available from the apparatus manufacturer or the Waterous Company. These special items are not absolutely necessary, but they will make the mechanic's work much easier.

### ***Preliminary Testing***

Before disassembling a pump, test it thoroughly, if possible, and record the results. A comparison of this test with periodic tests recommended in form F-1031, Section 1000 can often reveal specific pump troubles. Excessive speed, for instance, indicates that impellers and/or wear rings are probably worn.

### ***End Yoke and Companion Flange Nuts***

Do not reuse self-locking nuts. Apply lubrication to the threads before removing. Apply anti-seize to the threads before installing a new self-locking nut.

### ***Cleaning***

The continued satisfactory operation of a pump depends to a great extent upon the cleanliness of its internal parts. Sand, dirt or other abrasive material will wear gears and related parts. Before disassembling a pump for repairs, be sure to clean its exterior. Make sure the working space, benches and tools are clean. Use only clean, lint-free cloths to wipe off components. Before reassembling a pump or its components, be sure to clean them thoroughly.

### ***Pump Body and Impeller***

Flush out these components and related parts with clean water. Use a stiff brush to remove loose scale, caked sediment, etc. Examine pump body, adapters and fittings for cracks, severe corrosion or other damage. Almost all damage to these parts results from improper use or maintenance, or from freezing. Replace defective parts.

### ***Bearings, Seals and O-rings***

Parts of this nature are frequently damaged during removal or disassembly. In addition, they sometimes deteriorate or lose their effectiveness because of age or misuse. Replacing these parts whenever overhauling a pump is a good policy.

### ***Impeller Shaft***

Examine shaft for severe scratches, grooves or corrosion - especially under the mechanical seal. If scratches are not severe, and are not under the seal, clean them with a fine-cut file. Grooves are usually permissible if they are not sharp or too deep. Even slight longitudinal scratches will cause leaks and should be removed.

# Disassembly

## Remove Pump and Transmission from Vehicle

The pump and transmission must be removed as a unit from the vehicle. Refer to transmission overhaul instructions for additional details.

1. Drain the lubricant from the transmission or bearing housing.
2. Disconnect all accessories such as drain valves, priming pumps and shift units.
3. Disconnect the propeller shaft or shafts to the transmission or bearing housing.
4. Disconnect pump intake and discharge piping.
5. Remove the pump and transmission or pump and bearing housing as one unit.

## Remove Pump Intake Fitting

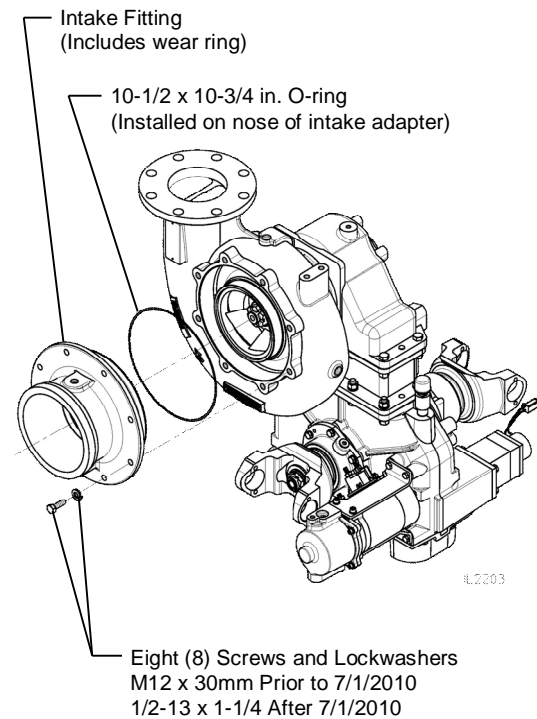

**S100C10, S100C20 and  
S100PA Series Models**  
(with End Suction Intake)

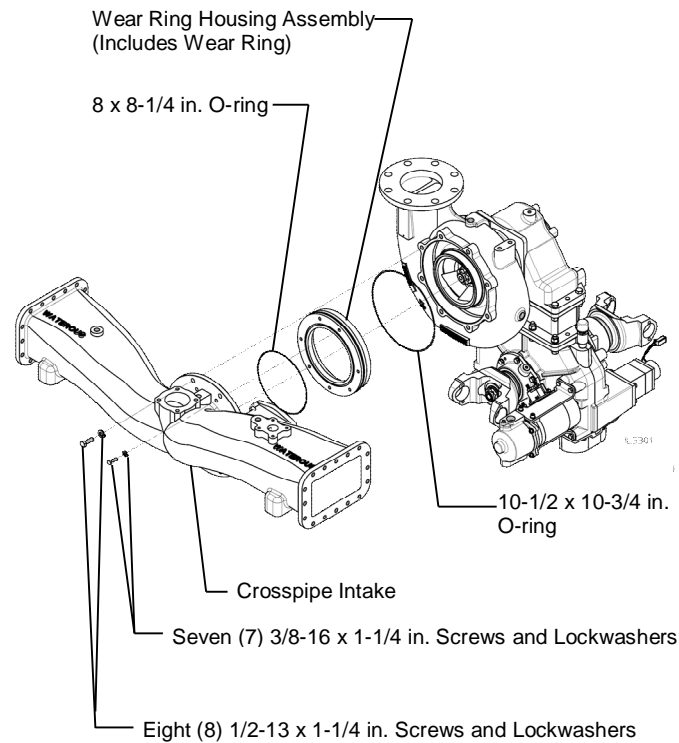

**S101C20 Series Models**  
(with Crosspipe Intake)

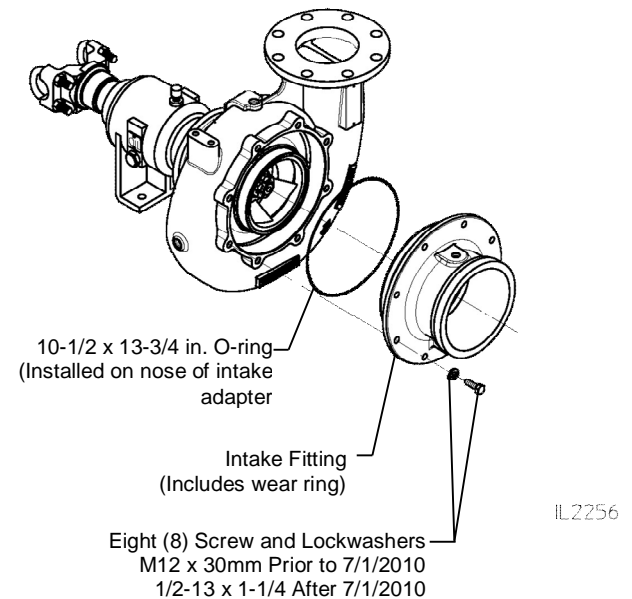

**S100D Direct Drive Models**  
(with End Suction Intake)

# Disassembly (Continued)

## Remove Impeller and Mechanical Seal

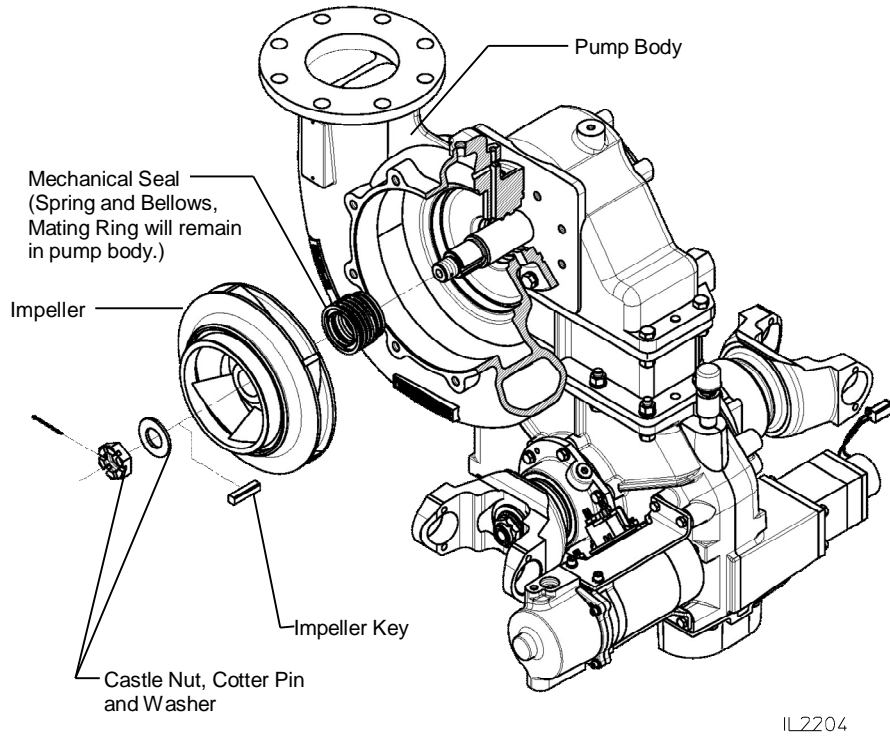

**S100C10, S100C20 and S100PA Series Models**  
(with End Suction Intake)  
and  
**S101C20 Series Models**  
(with Crosspipe Intake)

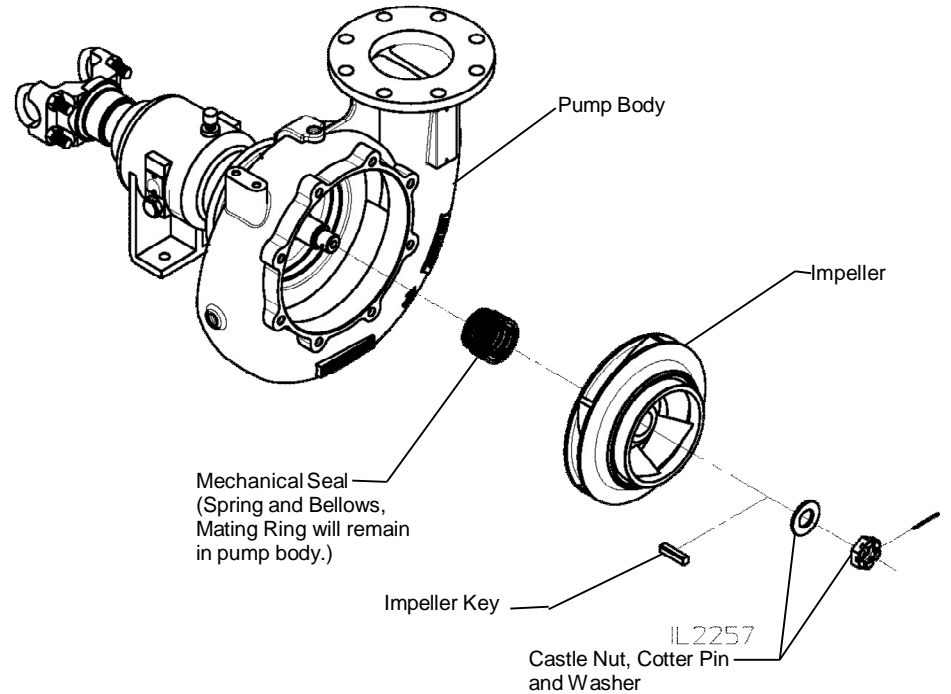

**S100D Direct Drive Models**  
(with End Suction Intake)



# Disassembly (Continued)

## Remove Pump Body

### C10 Transmission:

Eight (8) M12 x 30mm Screws and Lockwashers

### C20 Transmission:

Eight (8) 1/2-13 x 1-1/4 in. Screws and Lockwashers

### PA Transmission:

Eight (8) 1/2-13 Studs (Remain in Transmission)

Eight (8) 1/2-13 Nuts and Lockwashers

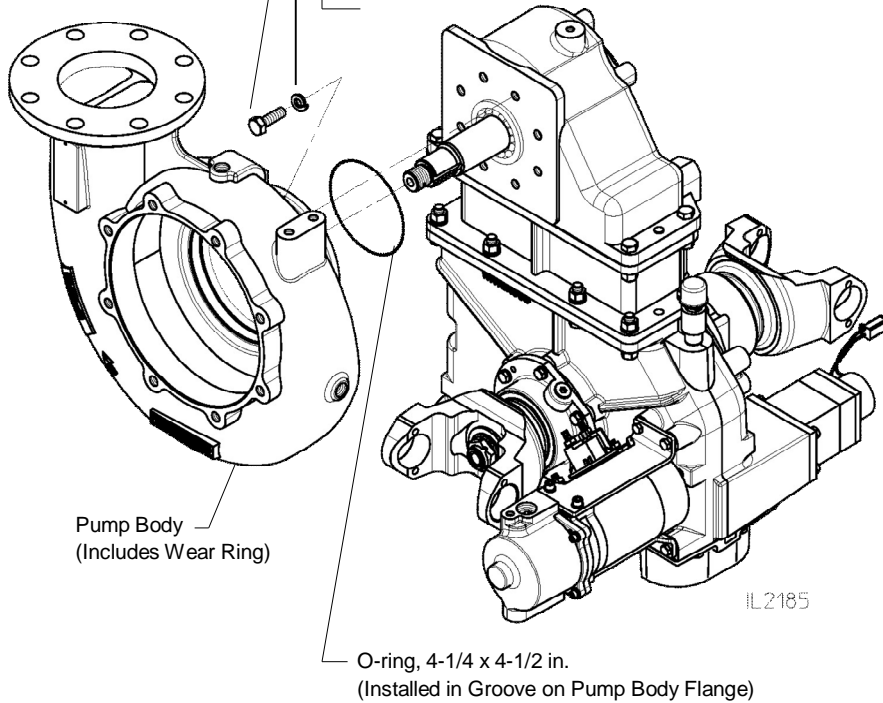

### S100C10, S100C20 and S100PA Series Models

(with End Suction Intake)

and

### S101C20 Series Models

(with Crosspipe Intake)

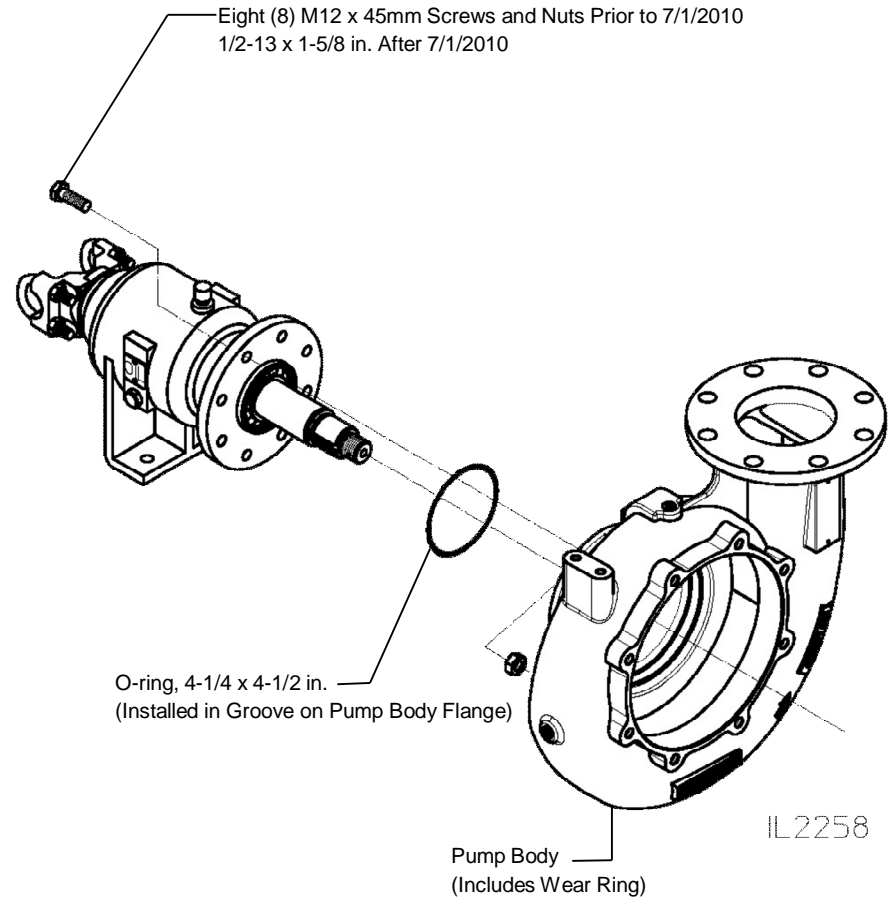

### S100D Direct Drive Models

(with End Suction Intake)

# Disassembly (Continued)

## Remove Seal Mating Ring and Oil Seal from Body

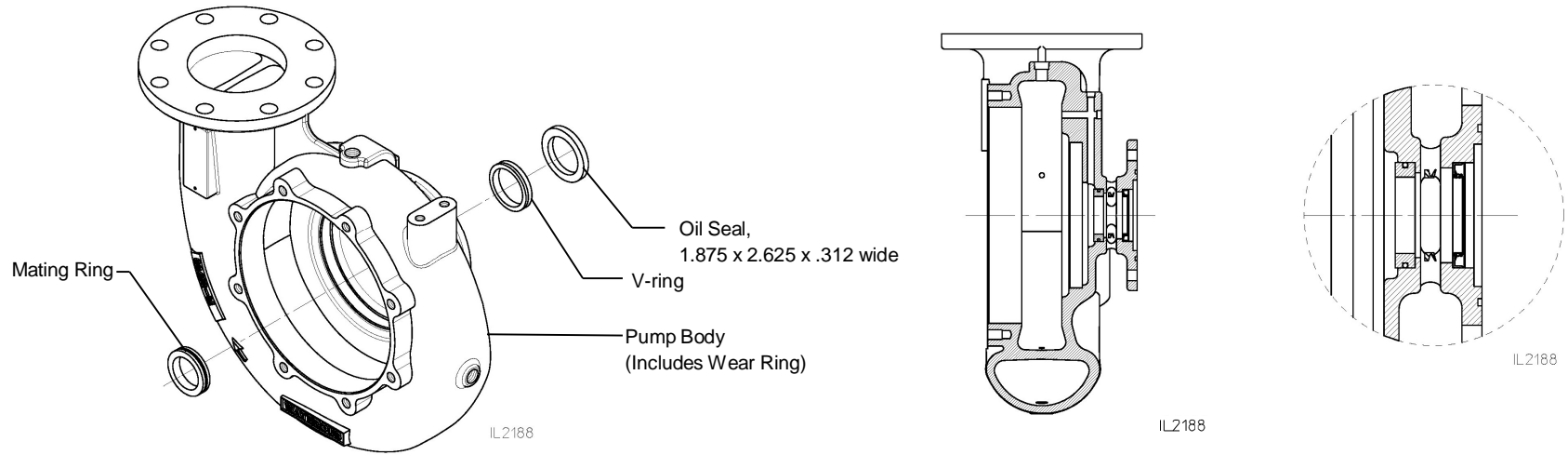

## Remove Impeller Shaft from Bearing Housing

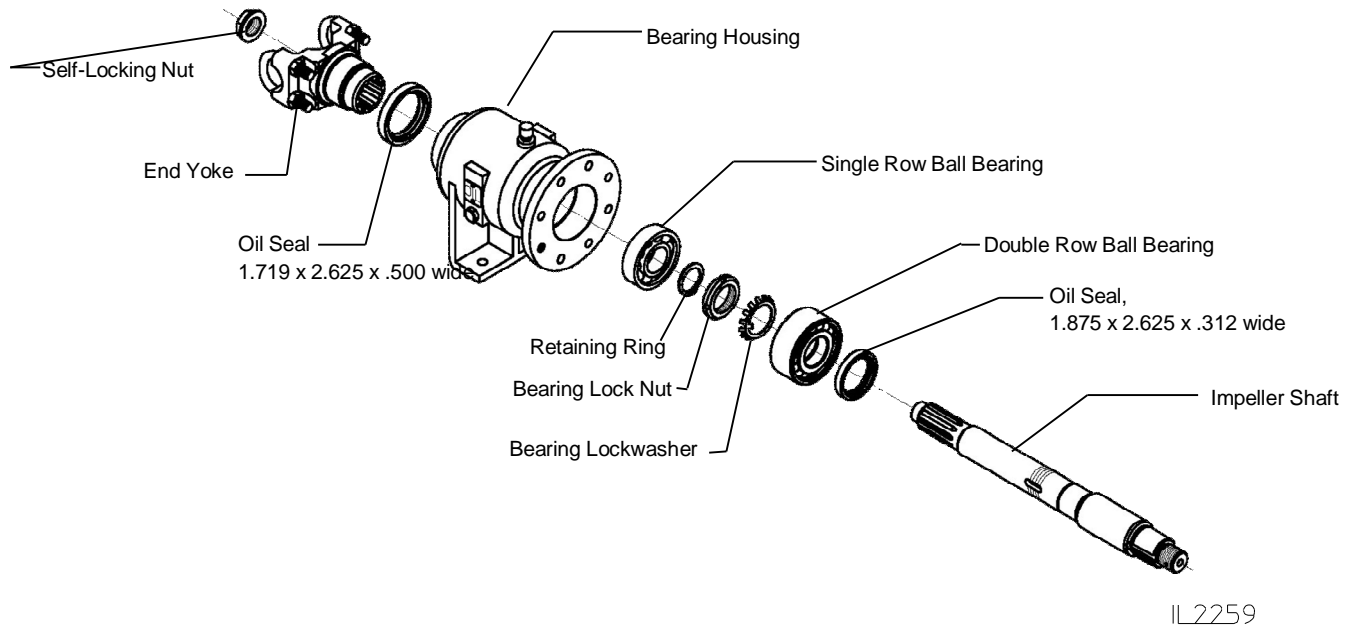

## Impeller, Wear Rings, Impeller Shaft, Volute Body and Intake Adapter

### Impeller and Wear Rings

Check wear rings and impeller hubs for deep grooves or scratches. Spiral grooves or grooves parallel to the impeller shaft increase leakage. Diametric clearances in excess of .029 inches may warrant wear ring replacement. Original factory clearance is .025 to .029 diametrically. The diametric clearance should be determined by averaging the results of four measurements taken at 90 degree increments as follows:

Clean and remove small burrs or other protrusions from the wear ring inner diameters and the impeller hub O.D. and I.D. Position each wear ring on the impeller hub on which it was used. Hold the wear ring firmly against one side of the hub and measure total clearance on the opposite side, using a feeler gauge. Do not bottom the wear ring against the bottom of the groove in the impeller.

### Installing Undersize Wear Rings

For all impellers which have separate wear rings, the replacement rings are available as follows:

- 0.025 in. undersize
- 0.050 in. undersize
- 0.075 in. undersize

If inspection shows that the wear ring clearances are excessive or the impeller hubs are scored or grooved, turn the impeller hub on a lathe to an acceptable dimension. Table 1 shows the original hub dimensions for each impeller and the rework dimensions for each degree of undersize.

**NOTE: Wear rings may be removed by crisscrossing two pry bars under opposite sides of the wear ring. Pry up the wear ring by applying equal pressure to both pry bars.**

**Table 1. Impeller and Wear Ring Repair Dimensions**

Original Impeller Hub Diameter	Original Wear Ring Part No.	New Wear Ring Part No.	Rework Diameter of Impeller Hub
6.734 / 6.736	73144	73144-25	6.709 / 6.707
		73144-50	6.684 / 6.682
		73144-75	6.659 / 6.657

Keep the hub diameters within 0.015 in. TIR of the impeller shaft bore. If the impeller hubs do not clean up at first undersize dimension, turn the hub down to the next degree of undersize. Replace the impeller if the hubs do not clean up at the last undersize dimension.

Before pressing new wear rings in place, remove all corrosion from body and head counterbores and apply Loctite 609 to the outer ring surfaces. With a suitable arbor, carefully press the rings into the body and head counterbores. Make sure the rings are seated firmly against the counterbore shoulders.

### Impeller Shaft

Examine shaft for signs of severe scratches, grooves or corrosion, especially under the oil seal or mechanical seals. If scratches are not severe, and are not under seals, they can be ignored. Check for cracks, pitting, twisted splines or damaged keyway.

Scratches in the area of the bellows of the mechanical seal can possibly be removed by spinning the shaft in a lathe and polishing with a fine emery cloth. The journal for the oil seal may be similarly cleaned, however, spiral type polishing may lead to oil leaks.

### Volute Body and Intake Adapter

Examine these for cracks, severe corrosion or other damage. Almost all damage to these parts results from improper use or maintenance, or from freezing. Replace defective parts.

Clean out drainage hole in volute body, located between the seat for the oil seal and mating seal ring of the mechanical seal.

# Reassembly

## Reassembly Steps

Reassembly of the S100 is essentially the same as the disassembly procedure, except it is reversed. Note that if undersize wear rings are required, they should be installed during reassembly. Also, if a new impeller is needed, install new standard size wear rings for the impeller.

**NOTE: These instructions are written based on installation of new wear rings, either standard size or under size. The wear ring hubs on the impeller are sized to suit.**

### S100C10, S100C20, S100PA and S101C20 Series Models

1. Slide both wear rings onto the impeller with the tapered (concave) end towards the impeller. With the inner wear ring overhanging the impeller by 1/4 inch there should be radial shake between the wear ring and impeller. Similar radial shake should exist between the outer wear ring and impeller with the wear ring overhanging the impeller by 1/8 inch. Do not bottom the wear rings with the impeller when checking for radial shake.
2. Inspect the bore for the wear ring in the intake adapter and volute body for any raised burrs or nicks that may have occurred when removing the old wear rings. Remove any burrs or nicks before installing new wear rings.
3. Position the intake adapter on a bench with the bore for the wear ring facing up. Position the wear ring in the bore with the square end down. Apply Loctite 609 to assist in wear ring retention. With a soft hammer, begin seating the ring squarely into the bore and then drive it down by hitting it evenly from side to side until it bottoms against the shoulder at the bottom of the bore.
4. Install the wear ring in the volute body the same way as that installed in the intake adapter.
5. Install oil seal in the volute body. Make sure the lip of the seal is facing toward the transmission.
6. Grease the O-ring area on the volute.
7. Install the O-ring in the volute.
8. Install the pump body onto the transmission securing it in place with the eight (8) hex head screws or hex nuts and lockwashers.
  - **S100C10 uses eight (8) M12 x 30mm screws and lockwashers. Torque to 64-69 lb-ft.**
  - **S101C20 uses eight (8) 1/2-13 x 1-1/4 in. screws and lockwashers. Torque to 75 lb-ft.**
  - **S100PA uses eight (8) 1/2-13 nuts and lockwashers that attach to 1/2-13 studs that remain in the transmission. Torque to 75 lb-ft.**

#### CAUTION

As the journal on the shaft for the oil seal begins to enter the oil seal, make sure the seal lip does not turn under or the garter spring in the seal does not pop out of position.

9. Install the V-ring on the impeller shaft. Use a screwdriver, punch or similar tool to push the V-ring through the mechanical seal bore and into place near the oil seal.

### S100D Direct Drive Models

1. Slide both wear rings onto the impeller with the tapered (concave) end towards the impeller. With the inner wear ring overhanging the impeller by 1/4 inch there should be radial shake between the wear ring and impeller. Similar radial shake should exist between the outer wear ring and impeller with the wear ring overhanging the impeller by 1/8 inch. Do not bottom the wear rings with the impeller when checking for radial shake.
2. Inspect the bore for the wear ring in the intake adapter and volute body for any raised burrs or nicks that may have occurred when removing the old wear rings. Remove any burrs or nicks before installing new wear rings.
3. Position the intake adapter on a bench with the bore for the wear ring facing up. Position the wear ring in the bore with the square end down. Apply Loctite 609 to assist in wear ring retention. With a soft hammer, begin seating the ring squarely into the bore and then drive it down by hitting it evenly from side to side until it bottoms against the shoulder at the bottom of the bore.
4. Install the wear ring in the volute body the same way as that installed in the intake adapter.
5. Install oil seal in the volute body. Make sure the lip of the seal is facing toward the transmission bearing housing.
6. Grease the O-ring area on the volute.
7. Install the O-ring in the volute.
8. Reassemble the impeller shaft assembly by pressing the ball bearing (double row) on the shaft. Secure in place by using the bearing lock nut and washer.
9. Install retaining ring.
10. Press the ball bearing (single row) on the shaft.
11. Install the oil seal in the bearing housing.
12. Slide the impeller shaft assembly into the bearing housing and secure in place by installing the end yoke and self-locking nut. Anti-seize should be applied to the threads before installing a self-locking nut. Do not reuse self-locking nuts. Note: Torque nut to 400-450 lb-ft.
13. Install the pump body onto the bearing housing securing it in place with the eight (8) M12 x 45mm screws and hex nuts. Torque to 64-69 lb-ft.
14. Install the pump body onto the transmission securing it in place with the eight hex head screws and lockwashers.

#### CAUTION

As the journal on the shaft for the oil seal begins to enter the oil seal, make sure the seal lip does not turn under or the garter spring in the seal does not pop out of position.

15. Install the V-ring on the impeller shaft. Use a screwdriver, punch or similar tool to push the V-ring through the mechanical seal bore and into place near the oil seal.

## Reassembly (Continued)

### Install Impeller and Mechanical Seal

#### CAUTION

The mechanical seal mating ring is made of silicon carbide. The material is brittle and can be cracked or chipped. Extra care must be taken when handling the mating ring.

**NOTE: If Waterous Mechanical Seal Lubricant part no. 52608 is not available, P80 rubber lubricant, straight dish soap or glycerin may be substituted.**

1. Apply a light coat of seal lubricant to the O-ring on the seal mating ring of the mechanical seal.

**NOTE: To protect the rubber bellows of the mechanical seal, place a piece of masking tape over the keyway on the impeller shaft, making sure that the tape is able to be removed after bellows has passed over the keyway.**

2. Slip the seal mating ring over the end of the impeller shaft with the finish lapped face of the seal ring facing up. Slide the seal mating ring along the shaft and push it into and seat it in the bore in the volute body. If it can not be pushed in by hand, it may be tapped into place by using a block of wood between the ring and a hammer. Protect the sealing face during installation.
3. Wipe the face of the previously installed mating seal ring of the mechanical seal with denatured alcohol and a clean lint-free cloth or tissue paper.

4. Wipe a few drops of seal lubricant on the inside of the bellows of the mechanical seal and wipe the face of the carbon ring with a lint-free cloth or tissue paper. Slide the seal onto the shaft until the carbon ring contacts the mating ring.
5. Install the spring over the seal assembly.
6. Install the key in the impeller shaft and then install the impeller, flat washer and impeller nut and snug up the nut. Rotate the impeller to assure seating of the mechanical seal spring into the counterbore on the backside of the impeller. If the spring is not properly seated it will snap into place when the impeller is rotated.
7. Tighten the impeller nut and line up slot in the nut with the hole in the shaft.
8. Install and secure the cotter pin.

#### Mechanical Seal Lubricant Application

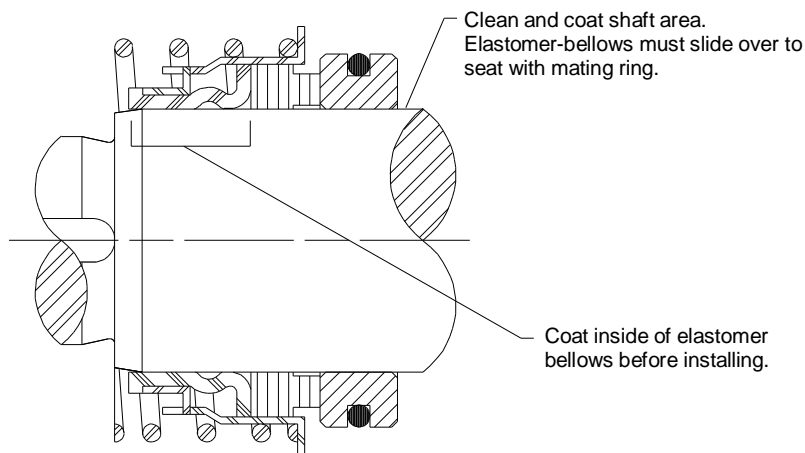

IL 1024

# Reassembly (Continued)

## Install Intake Fitting

### S100C10, S100C20, S100PA and S100D Series Models

- Grease O-ring and install on the intake adapter.
- Position the intake adapter on the volute body. Line up holes and install the eight (8) M12 x 30mm (prior to 7/1/2010) 1/2-13 x 1-1/4 in. (after 7/1/2010) screws and lockwashers screws and lockwashers. Tighten until the surface of the adapter meets the surface of the volute body.
- Rotate the impeller shaft. Make sure the wear rings and the impeller are not rubbing against each other.
- If the impeller turns freely, tighten the screws evenly from side to side (torque to 64-69 lb-ft).

**NOTE: If the impeller rubs against the wear rings, remove the adapter and determine the cause. The following can cause rubbing:**

- Raised burr or nick on either the hub of the impeller or on the wear ring.
- Wear ring is cocked when installed and is deformed sufficiently to rub on the impeller.
- Impeller hub is not reworked to correct size for use with the new undersize wear ring.

After correcting the problem of rubbing between the impeller and wear rings, reinstall the intake adapter.

### S101C20 Series Models

- Grease both O-rings and install on the wear ring housing.
- Line up the wear ring housing onto the crosspipe intake and secure using seven (7) 3/8-16 x 1-1/4 in. screws and lockwashers (torque to 31 lb-ft.)
- Position the crosspipe on the volute body. Line up holes and install the eight (8) 1/2-13 x 1-1/4 in. screws and lockwashers. Tighten until the surface of the adapter meets the surface of the volute body.
- Rotate the impeller shaft. Make sure the wear rings and the impeller are not rubbing against each other.
- If the impeller turns freely, tighten the screws evenly from side to side (torque to 64-69 lb-ft.).

**NOTE: If the impeller rubs against the wear rings, remove the adapter and determine the cause. The following can cause rubbing:**

- Raised burr or nick on either the hub of the impeller or on the wear ring.
- Wear ring is cocked when installed and is deformed sufficiently to rub on the impeller.
- Impeller hub is not reworked to correct size for use with the new undersize wear ring.

After correcting the problem of rubbing between the impeller and wear rings, reinstall the intake adapter.

### S100C10, S100C20 and S100PA Series Models

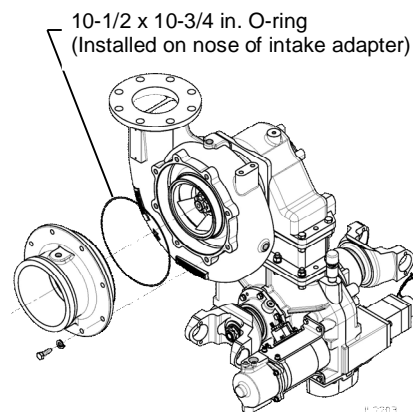

### S100D Direct Drive Models

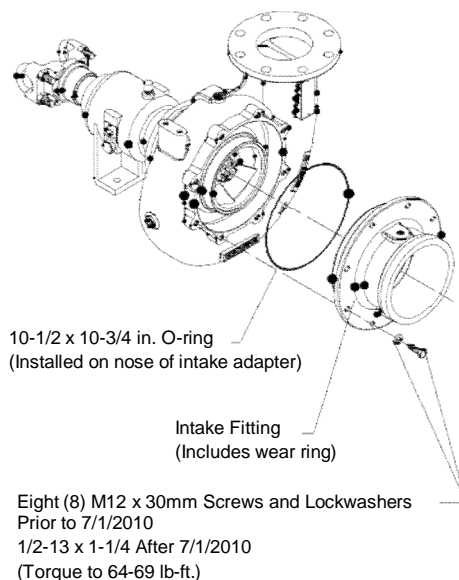

### Wear Ring Housing Assembly (Includes Wear Ring)

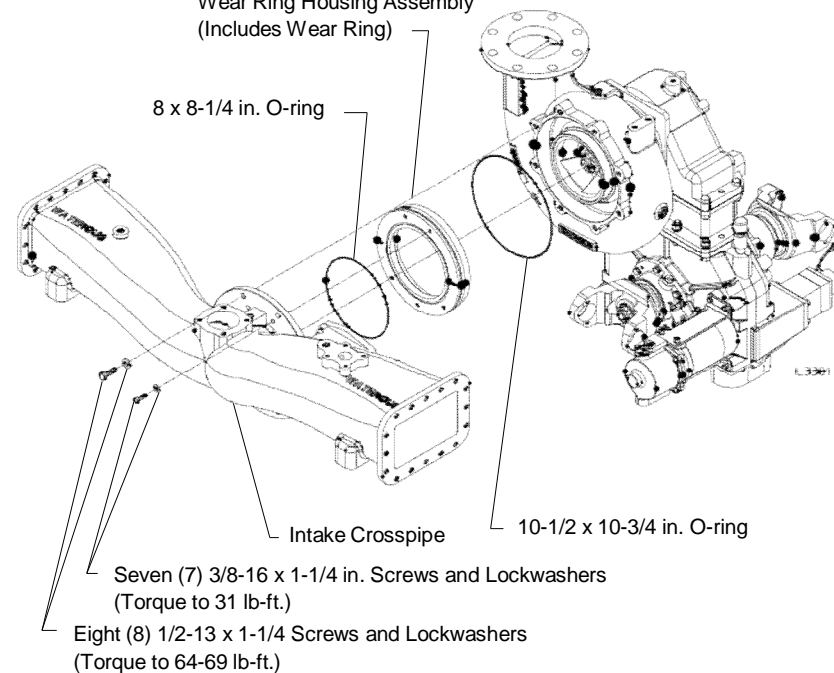

# Reassembly (Continued)

## Cross-Section Views

S100C10, S100C20 and S100PA Series Models (with End Suction Intake)

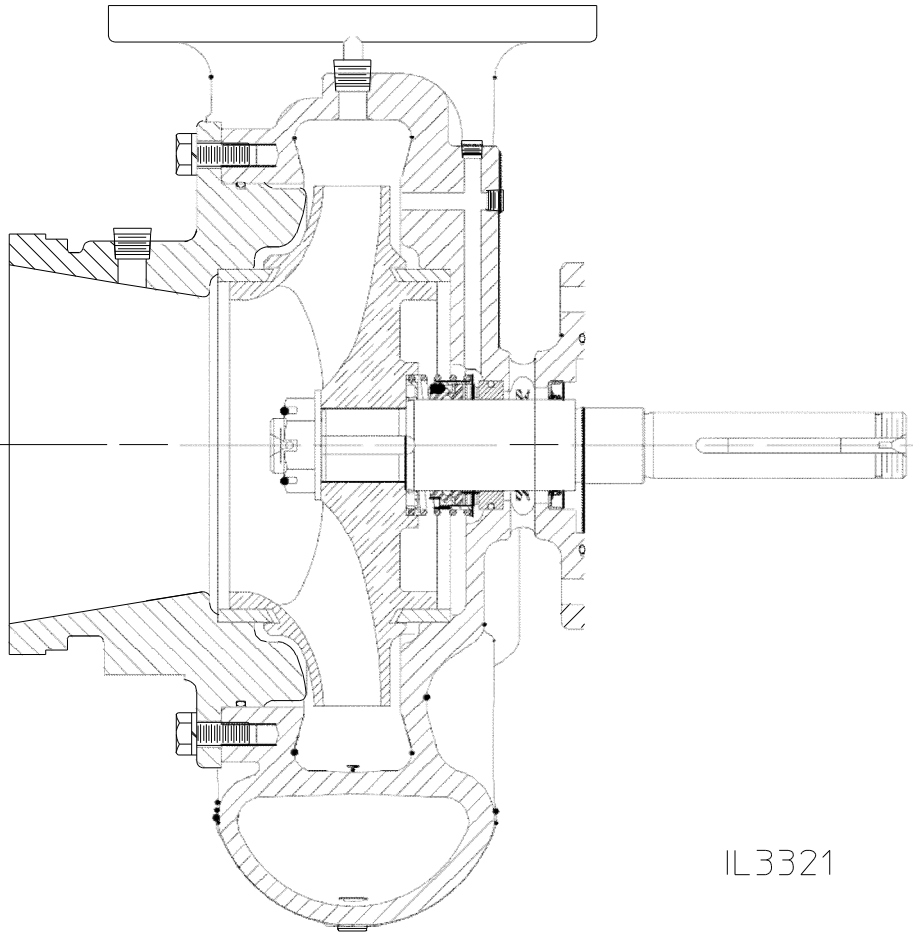

S101C20 Series Models (with Crosspipe Intake)

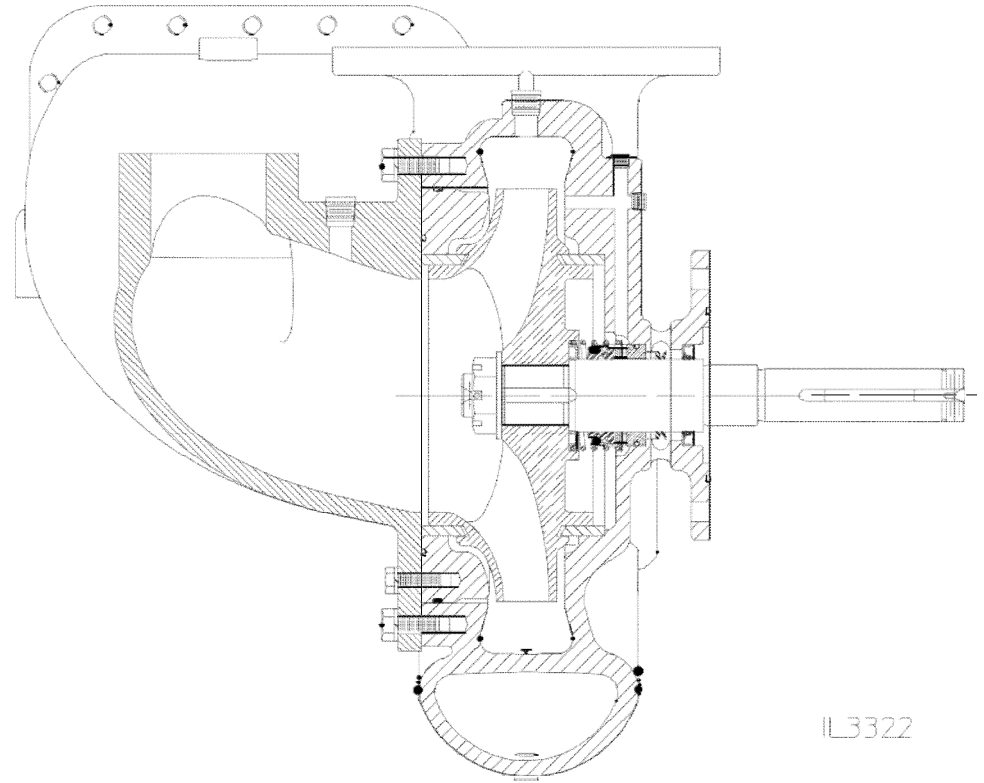

# Reassembly (Continued)

## Cross-Section Views

S100D Direct Drive Models (with End Suction Intake)

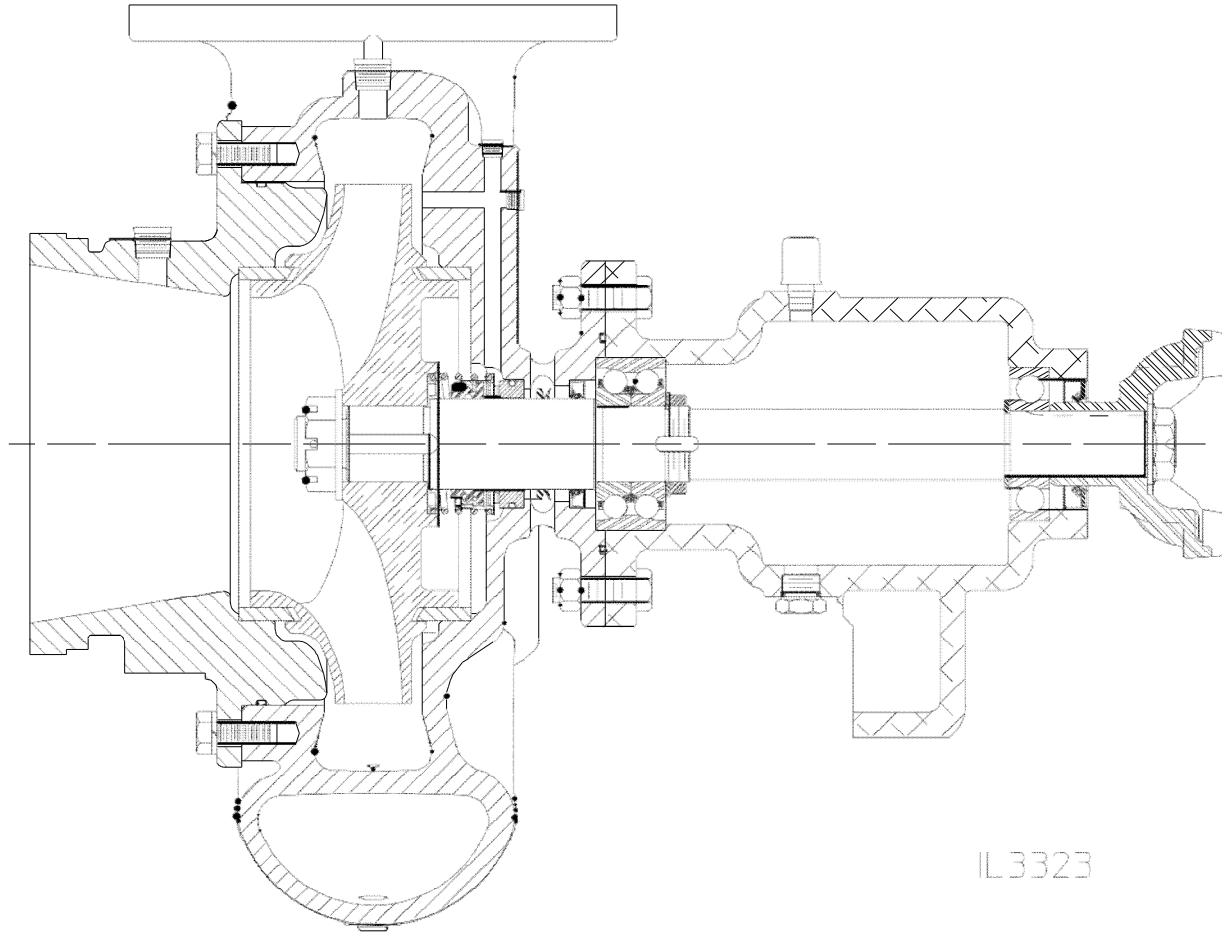



# Reassembly (Continued)

## Final Assembly Steps

To complete final assembly, perform the following:

1. Install pump and transmission/bearing housing in truck.
2. Connect the intake and discharge piping.
3. Connect propeller or drive shaft to transmission or bearing housing.
4. Connect the cooling and drain lines, electrical wiring and similar equipment to the pump and accessories.

## Lubrication

Fill the transmission or bearing housing with lubricant as follows.

### S100C10, S100C20, S100PA and S101C20 Series Models:

Drive Type	Approximate Quantities	Lubricant Type
C10 Transmission	12 quarts	ATF
C20 Transmission	6 quarts	ATF
PA Transmission	3 quarts	ATF

### S100D Direct Drive Models:

Drive Type	Approximate Quantities	Lubricant Type
Bearing Housing	1/2 quart	ATF or SAE 30 oil (non-detergent)

# Testing

Before returning the pump to service, it is advisable to perform hydrostatic and operational tests to check for leaks and to ensure the pump operates properly.

Hydrostatic	Operational
<ol style="list-style-type: none"><li>1. Connect the pump to a hydrant or other pressurized water supply.</li><li>2. Close all drain lines and open the discharge and priming valves.</li><li>3. Open hydrant until the water runs out through the discharge valves and discharge pipe in priming pump (if used).</li><li>4. Close all valves. Be sure to evacuate all air from the pump.</li><li>5. Check for leaks with a portable light. If leaks are discovered, tighten connections or attaching parts as necessary. Repeat until all leaks are eliminated.</li></ol> <p><b>Note: The mechanical seal may leak under hydrostatic pressure; however, it should stop leaking after the seal faces are run in during operational testing.</b></p> <ol style="list-style-type: none"><li>6. Shut hydrant valve after all leaks are eliminated.</li><li>7. Drain pump completely and disconnect intake hose.</li></ol>	<ol style="list-style-type: none"><li>1. Operate the pump at its maximum intended service pressure. (Refer to NFPA 1911).</li><li>2. Check for leaks with a portable light. If leaks are discovered, stop the pump and tighten connections or tighten attaching parts as necessary. Repeat until all leaks are eliminated.</li><li>3. Check for unusual noises, oil leaks, overheated bearings, etc. while the pump is running. If anything unusual is discovered, stop the pump immediately and determine the cause of the problem.</li></ol>

# Testing