

WATEROUS

Form Number F-2915

Issue Date: May 27, 2021

Revision Date: Jul 6, 2021

CP-4 and CP-4UH Overhaul Instructions

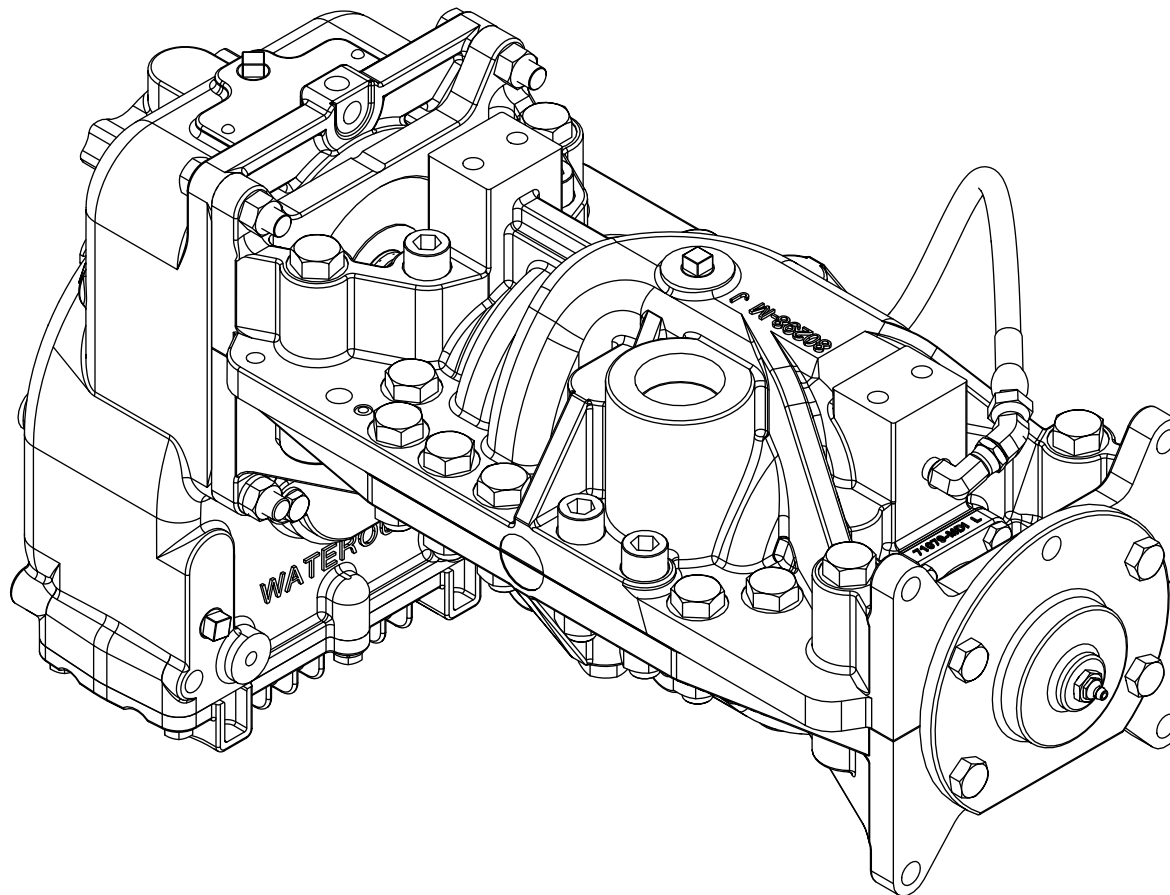

Waterous Company • 125 Hardman Avenue South • South Saint Paul, MN 55075 • (651) 450-5000

www.waterousco.com

Table of Contents

Safety	4	Assembly	21
Safety Precautions	4	Preparing to Assemble the Pump	21
Introduction	5	Tools Required	21
Using this Document	5	Best Practices	21
Viewing the Document Electronically	5	Optional Equipment	21
Printing the Document	5	Assembling the Pump Components	21
Symbols	5	Installing the Pump	21
Identifying Exterior Components—Top	6	Understanding the Illustrations	21
Identifying Exterior Components—Bottom	7	Impeller Shaft Assembly	22
Disassembly	8	Assembling the Bearing Housing	23
Preparing to Disassemble the Pump	8	Assembling the Impeller Shaft	24
Tools Required	8	Installing and Tightening the Packing	27
Preparing the Apparatus	8	Pump Body Assembly	28
Best Practices	8	Installing the Lower Pump Body	30
Removing the Pump	8	Installing the Bearing Cover	31
Disassembling the Pump Components	8	Installing the Upper Pump Body	32
Optional Equipment	8	Installing the Pump Body Hardware	34
Separating the Pump and Transmission	9	Installing the Packing Housing Hardware	35
Removing the Packing Cooler Hose	9	Installing the Flinger Ring and Bearing	36
Removing the Bearing Housing	10	Installing the Bearing Housing	37
Removing the Packing Housing Screws	11	Installing the Packing Cooler Hose	38
Removing the Pump Body Hardware	12	Testing After Installation	39
Removing the Dowel Pins	14		
Removing the Upper Pump Body and Bearing Cover	15		
Removing the Lower Pump Body	16		
Removing the Impeller Shaft Assembly	17		
Removing the Impeller Shaft Components	18		

Safety Precautions

- Read and understand this document before you begin the overhaul.
- Read and understand all the notices and safety precautions.
- Be aware that these instructions are only guidelines and are not meant to be definitive. Contact Waterous when you have questions.
- Do not overhaul this equipment if you are not familiar with the tools and skills needed to safely perform the required procedures.
- Do not modify the equipment.
- Waterous reserves the right to make modifications to the instructions without notice.

WARNING

Unsupported Equipment

- Unsupported equipment may shift or fall during disassembly, causing injury or damage.
- Always support heavy equipment while servicing.

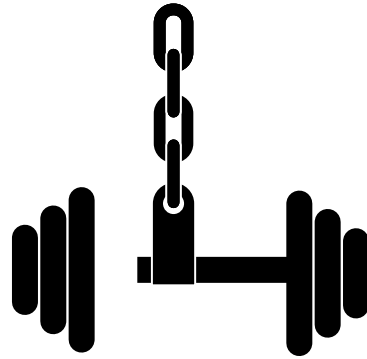

WARNING

Hot Surface

- Hot surface can burn you.
- Do not touch the surface during operation—allow it to cool after operating.

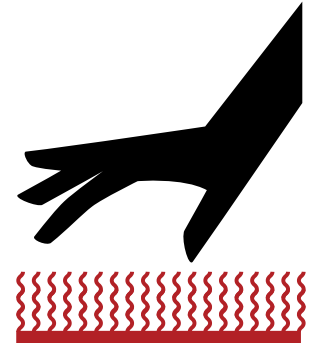

WARNING

High Pressure

- Liquid ejected at high pressure can cause serious injury.
- Drain the pump after use and before servicing.

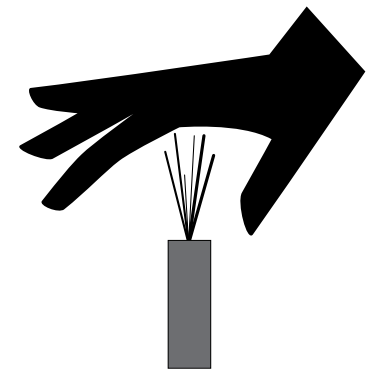

Use this document to overhaul your Waterous equipment. Please understand the following conditions:

- Be aware that these instructions are only guidelines and are not meant to be definitive. Contact Waterous when you have questions.
- Understand that your configuration may require additional steps, that are not described in the illustrations or instructions, to perform the overhaul.
- The equipment described in this document is intended to be overhauled by a person or persons with the necessary skills and knowledge to perform the overhaul.

This document is divided into the following sections:

SAFETY

This section describes general precautions and alert symbols that are in this document.

INTRODUCTION

This section is an overview of the document.

DISASSEMBLY

This section describes disassembly procedures.

ASSEMBLY

This section describes assembly procedures.

Using this Document

Use the guidelines below when viewing this document.

Viewing the Document Electronically

- View this document in landscape orientation.
- Use the table of contents to navigate directly to that section.
- Text **with this appearance** is linked to a reference.

Printing the Document

- The document is viewed the best when printed in color.
- The *print on both sides* and *flip on long edge* features can provide the best results.
- Use a 3-ring binder to store the document.

Symbols

Symbols are used to illustrate additional tools or operations that are required to complete the instruction.



Arbor press—This symbol tells you to use an arbor press to complete this step.



Discard—This symbol tells you to discard or recycle the part in accordance with local regulations.



Finger tight, then full turn—This symbol tells you to secure the hardware to finger tight, then use a wrench to tighten the hardware an additional turn.



High-pressure grease—This symbol tells you to apply high-pressure grease to the surfaces that you are pressing together.



Lubrication—This symbol tells you to apply the appropriate lubricant to the part.



Sealant—This symbol tells you to apply a appropriate sealant to the part.



Torque to specification—This symbol tells you to torque the hardware to the specified value.

Identifying Exterior Components—Top

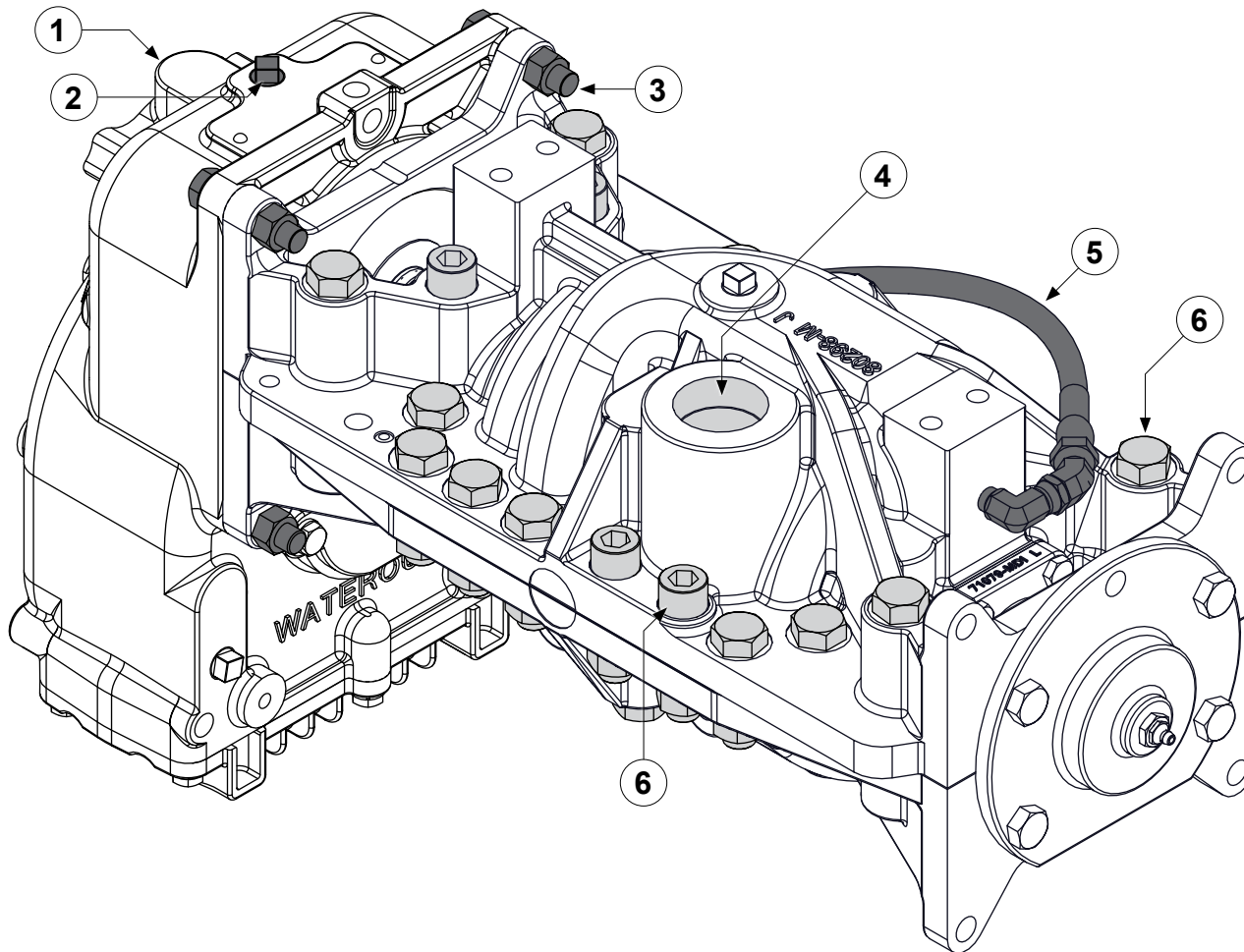

Use the illustration to identify various components on the pump.

- | | |
|---|--------------------------------|
| 1 | Transmission |
| 2 | Oil fill plug |
| 3 | Transmission mounting hardware |
| 4 | Discharge |
| 5 | Packing cooler hose |
| 6 | Flange hardware |

Identifying Exterior Components—Bottom

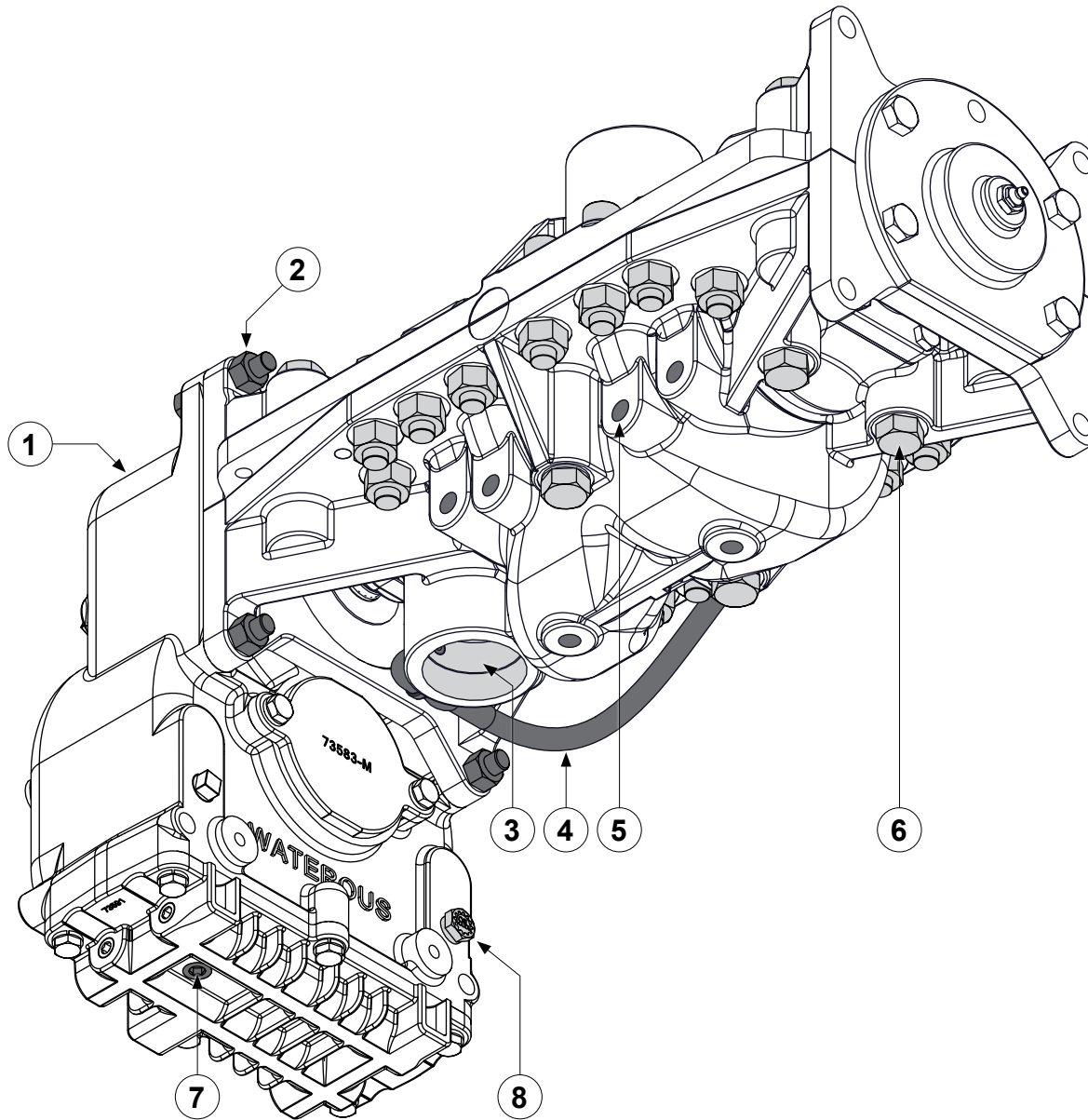

Use the illustration to identify various components on the pump.

- | | |
|---|--------------------------------|
| 1 | Transmission |
| 2 | Transmission mounting hardware |
| 3 | Intake |
| 4 | Packing cooler hose |
| 5 | Drain port |
| 6 | Flange hardware |
| 7 | Oil drain plug |
| 8 | Oil level plug |

Preparing to Disassemble the Pump

- Read and understand the instructions before disassembling the equipment.
- Prepare a workspace suitable to accommodate and support the pump.
- Gather the necessary tools, cleaning cloths, brushes, and penetrating fluids.
- Understand that your configuration may require additional steps that are not described in the illustrations or instructions to perform the disassembly.
- This equipment is intended to be disassembled by a person or persons with the basic knowledge of servicing similar equipment. Contact Waterous for more information.

Tools Required

- Typical automotive mechanics hand tools.
- Suitable arbor press.
- Suitable support and lifting equipment.

Preparing the Apparatus

- Park the apparatus on a level surface in a well-lit area.
- Engage the parking brake.
- Shut off the engine and remove the key from the ignition switch.
- Allow the apparatus to cool before servicing.

Best Practices

- Remove any dirt, sand, grease, or oil from the enclosure before you disassemble the transmission. Surface debris can transfer into the pump interior and prematurely wear internal parts.
- Only use a clean lint-free cloth, a debris-free work surface, and properly maintained tools to perform the disassembly.
- Replace any gaskets and O-ring seals during the overhaul.
- Do not reuse the self-locking nuts.
- Apply penetrating oil to screws and nuts before disassembly.

Removing the Pump

Removing the pump for overhaul varies by application. Your application may require components such as drain lines, support brackets, plumbing connections, and other accessories be removed or disconnected before removing the pump.

Furthermore, some applications require you to remove the transmission and pump together before separating the pump from the transmission. Other applications allow you to separate the pump without removing the transmission from the apparatus. Refer to the transmission instructions before proceeding.

Record the process used to remove the equipment from the apparatus. Use this information to install the equipment into the apparatus after the overhaul.

Disassembling the Pump Components

- Refer to the service parts list (SPL) for part identification and disassemble order.

Note: Documents specific to your application are available through the MyWaterous login at Waterousco.com by entering the serial number for your system. Depending on the application, the serial number for your equipment is located on the operator panel, pump, transmission, or some combination of the three.

- Use established industry practices to disassemble the pump.
- Record or mark components as you remove them to make sure that you install them in the same orientation.
- Discard or recycle drained fluids collected during the overhaul in accordance with local regulations.

Optional Equipment

Be aware that the disassembly instructions may include optional equipment not included in your application.

Separating the Pump and Transmission

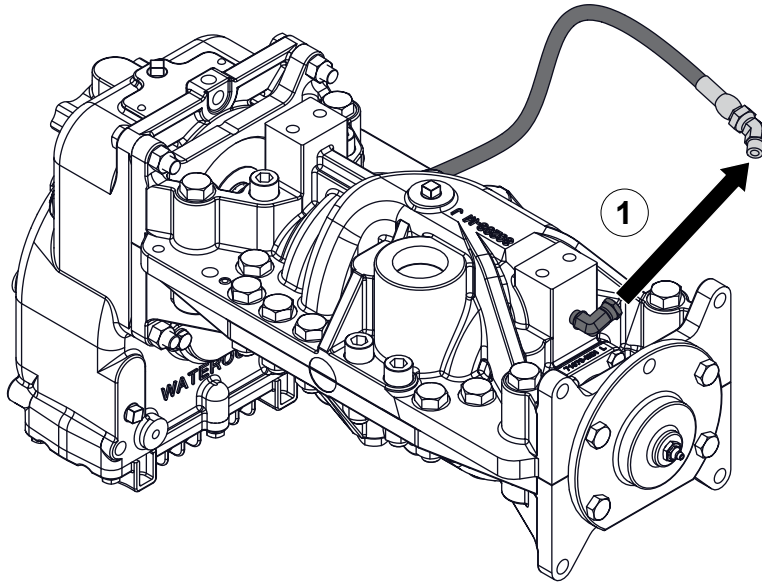

Removing the Packing Cooler Hose

Use the illustrations and instructions to remove the packing cooler hose.

- 1 Remove the hose from the upper pump body fitting.
- 2 Remove the hose from the pump intake fitting.

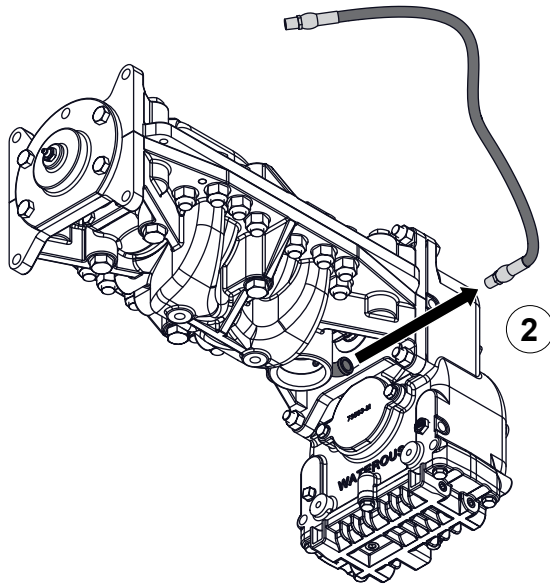

Separating the Pump and Transmission

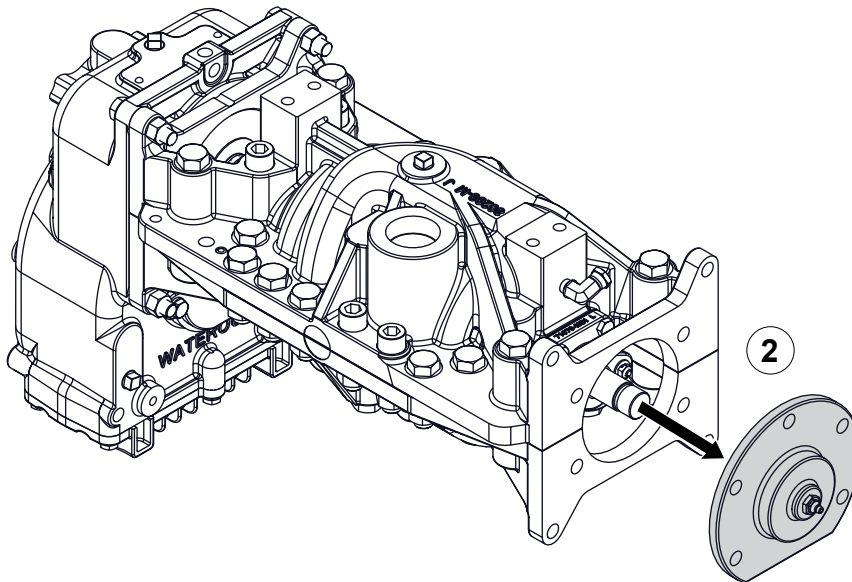
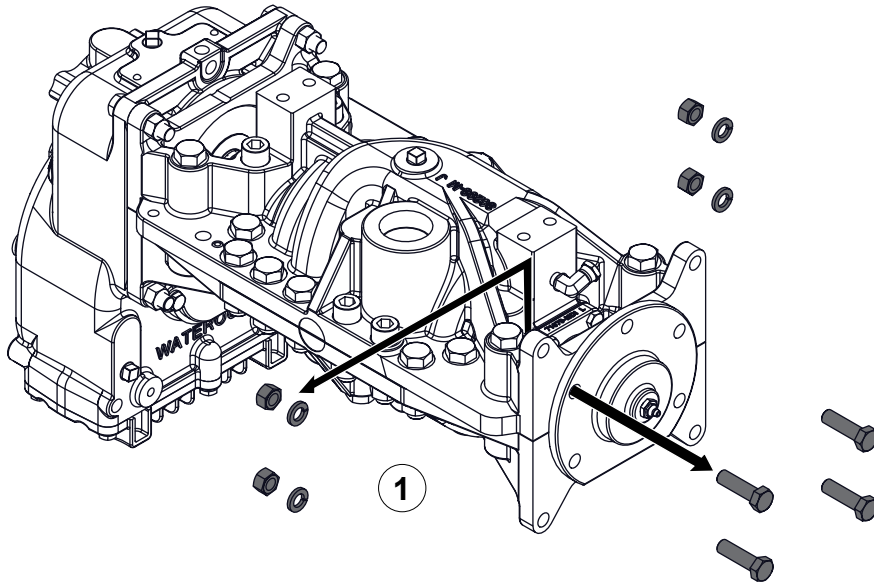

Removing the Bearing Housing

Use the illustrations and instructions to remove the bearing housing.

- 1 Remove the bearing housing hardware.
- 2 Remove the bearing housing and bearing from the pump.

Note: In some cases, the bearing housing and bearing may need to be removed separately.

Separating the Pump and Transmission

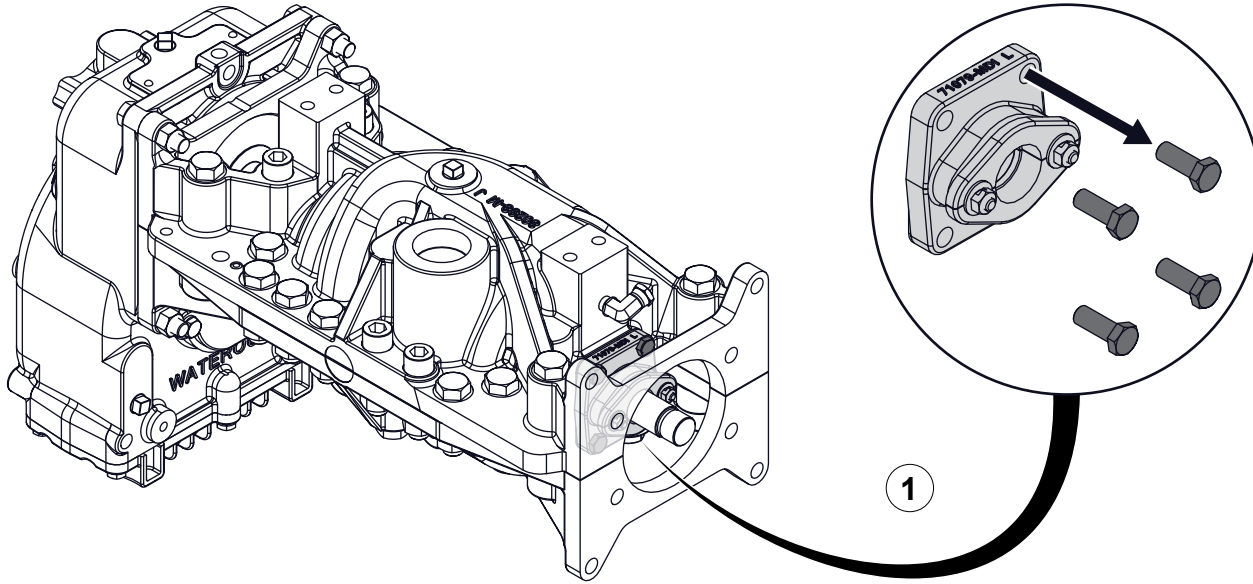

Removing the Packing Housing Screws

Use the illustrations and instructions to remove the packing housing hardware.

- 1 Remove the packing housing screws.
- 2 Remove the packing housing screws.

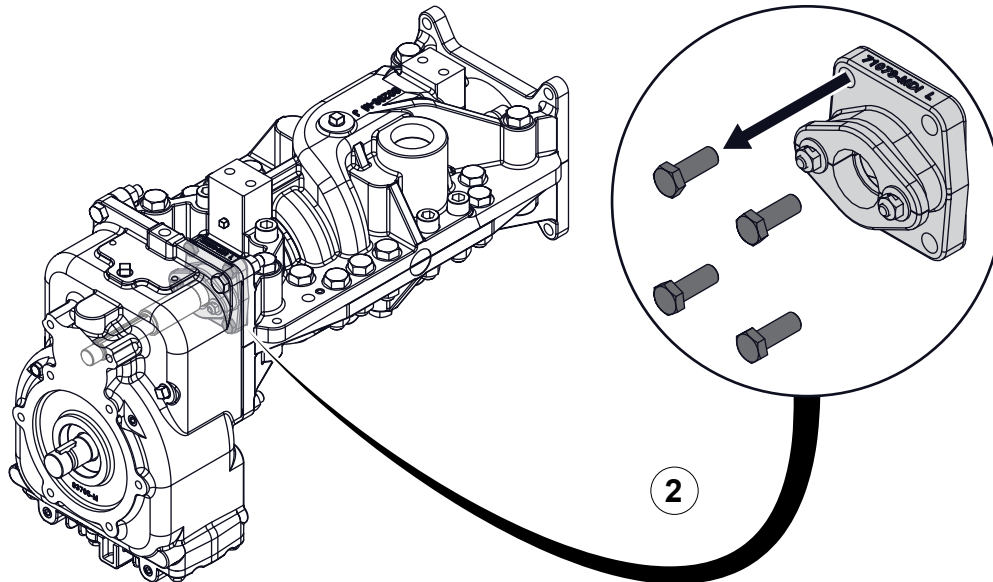

Separating the Pump and Transmission

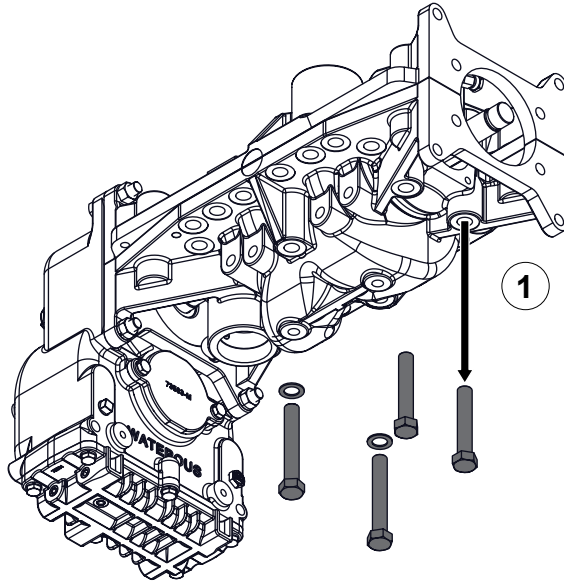

Removing the Pump Body Hardware

Use the illustrations and instructions to remove the pump body hardware.

- 1 Remove the hardware from the lower pump body.
- 2 Remove the hardware from the upper pump body.

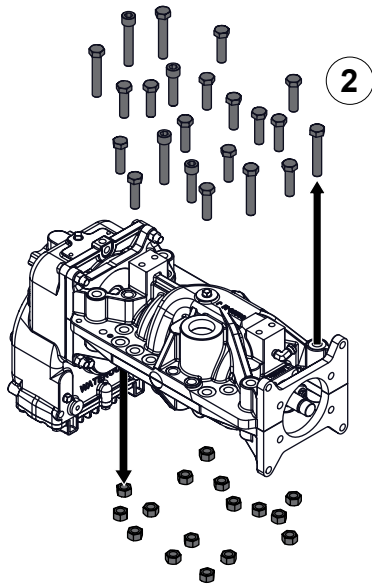

Separating the Pump and Transmission

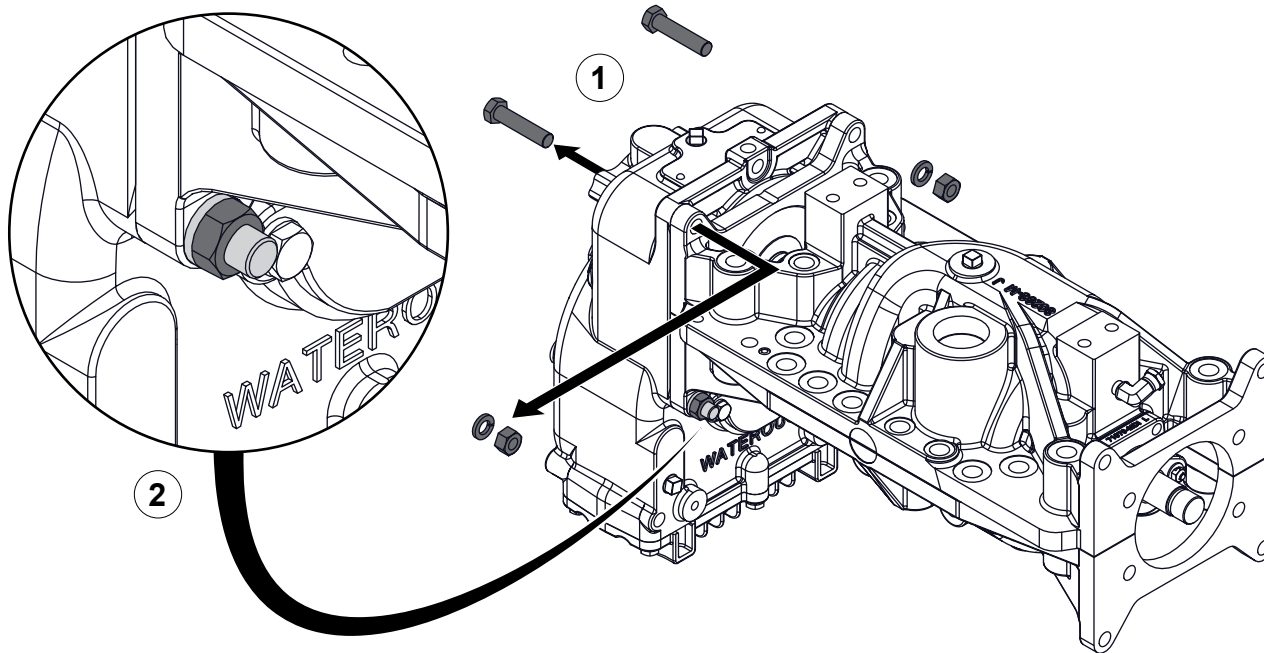

Removing the Transmission Hardware

Use the illustration and instructions to remove the upper transmission mounting hardware.

- 1 Remove the upper transmission mounting hardware.
- 2 Loosen, but do not remove, the lower transmission mounting hardware.

Separating the Pump and Transmission

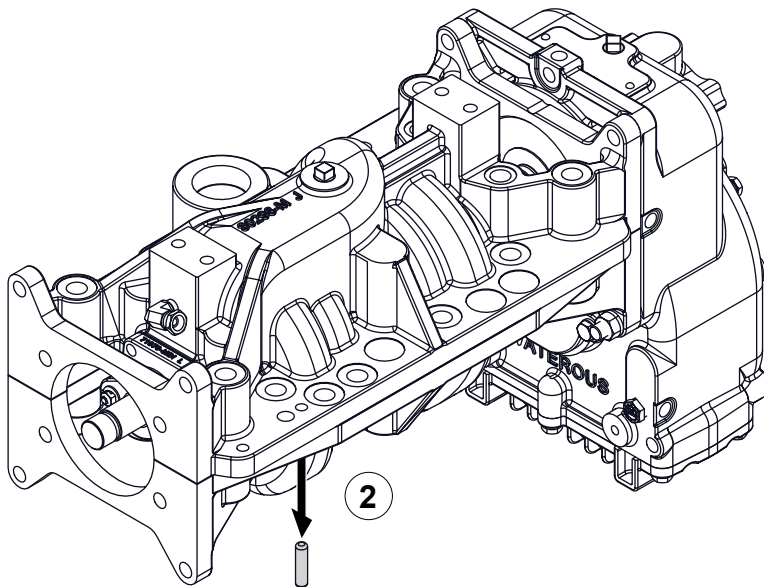
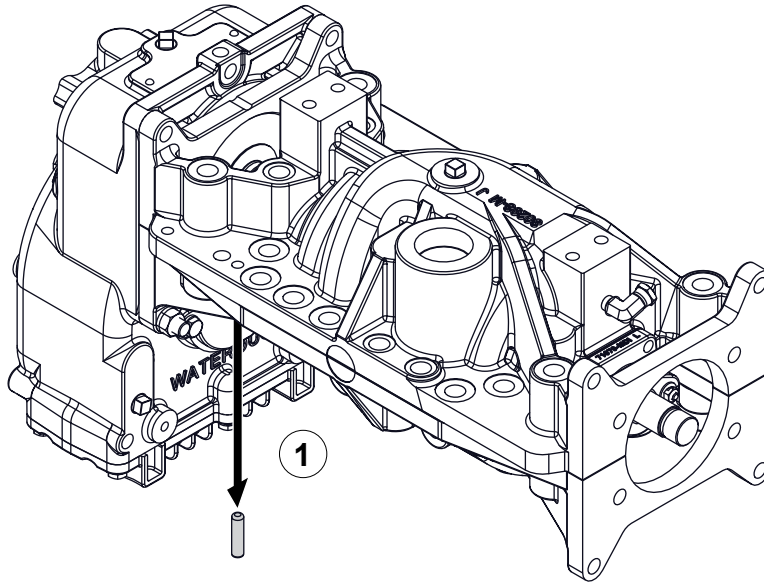

Removing the Dowel Pins

Use the illustrations and instructions to remove the dowel pins from the pump bodies.

- 1 Use a hammer and punch to remove the dowel pin.
- 2 Use a hammer and punch to remove the dowel pin.

Separating the Pump and Transmission

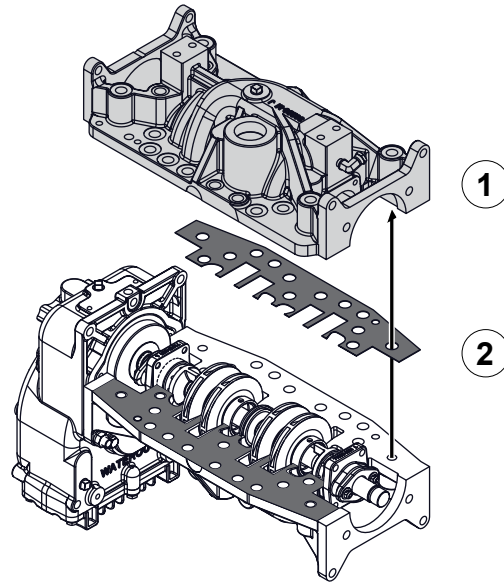

Removing the Upper Pump Body and Bearing Cover

Use the illustrations and instructions to remove the upper pump body, gasket, and bearing cover.

- 1 Remove the upper pump body.

Note: If needed, there are jacking screw holes to aid in separating the pump bodies.

- 2 Remove and discard the gasket material.
- 3 Remove the mounting hardware, bearing cover, and O-ring, then discard the O-ring.

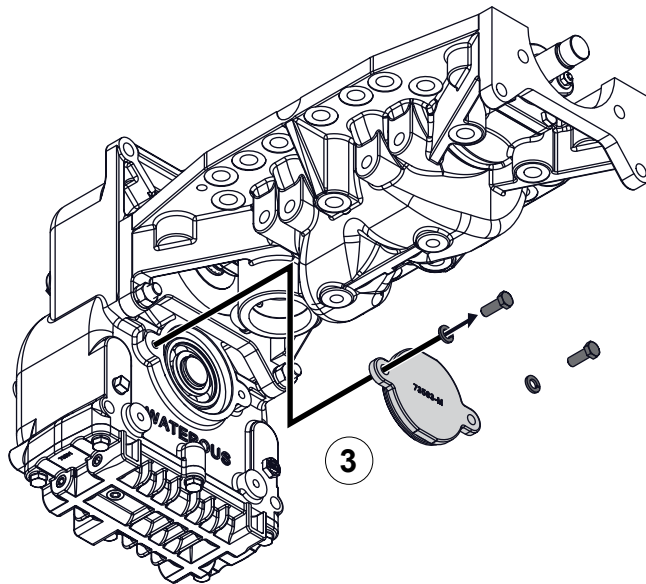

Separating the Pump and Transmission

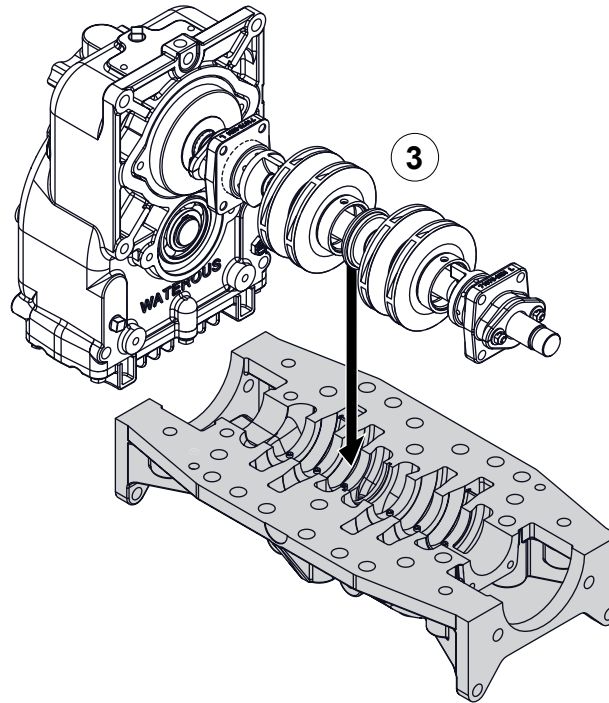
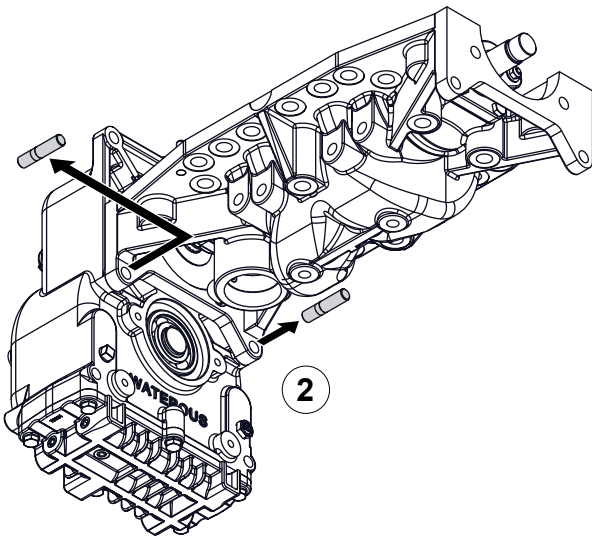
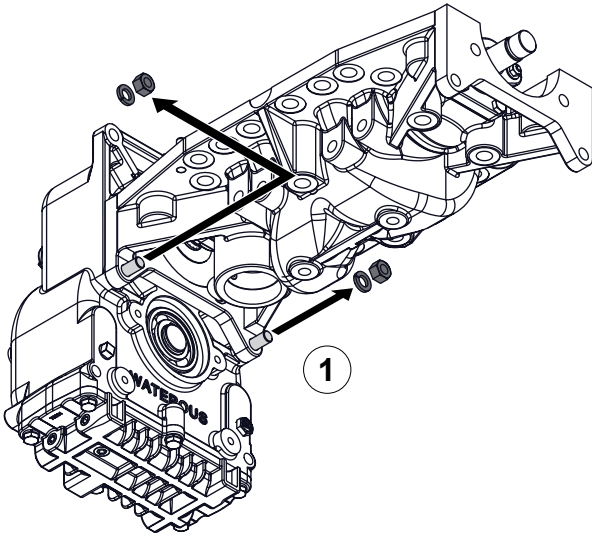

Removing the Lower Pump Body

Use the illustrations and instructions to remove the remaining transmission mounting hardware and lower pump body.

- 1 Remove the nuts and washers.
- 2 Remove the threaded studs.
- 3 Remove the lower pump body.

Separating the Impeller Shaft Components

Removing the Impeller Shaft Assembly

Use the illustrations and instructions to remove the impeller shaft assembly.

- 1 Use locally sourced jacking screws (3/8-24 UNF with a minimum length of 1-1/2 inches) to separate the impeller shaft assembly and transmission case.
- 2 Remove the impeller shaft assembly from the transmission case.

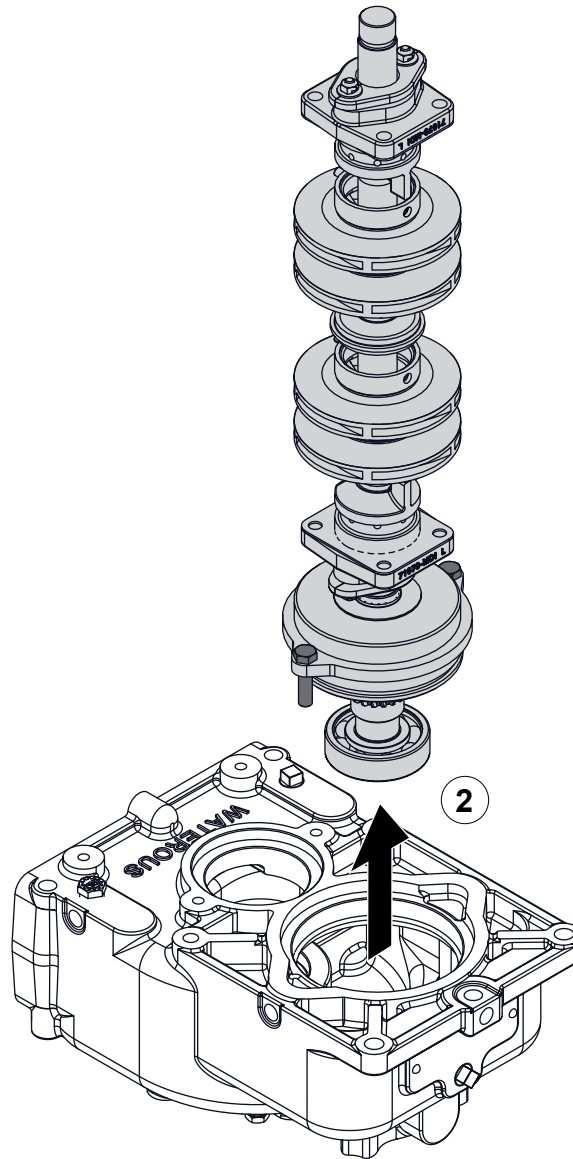
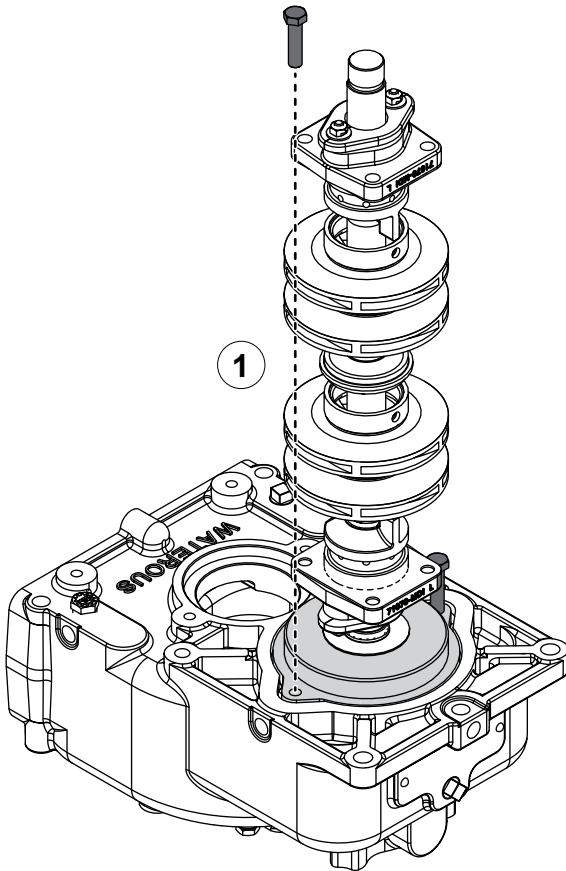

Removing the Impeller Shaft Components

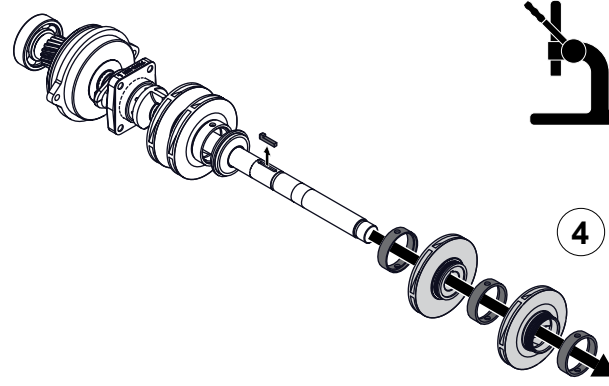
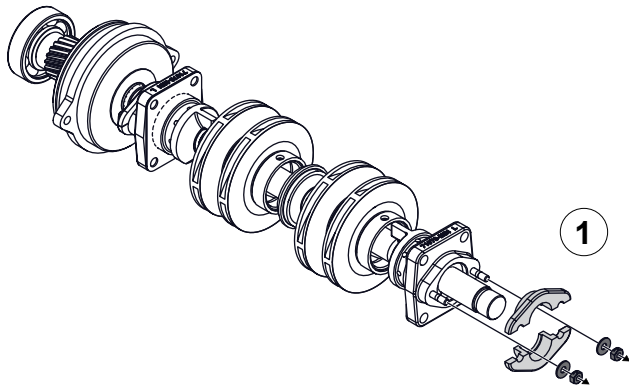

Use the illustrations and instructions to disassemble the impeller shaft.

- 1 Remove the hardware and gland halves.
- 2 Remove the packing rings and packing housing. Discard the gasket.
- 3 Remove the retaining ring.
- 4 Use an arbor press to remove the wear rings and impellers up to the interstage seal. Remove the key after removing the second impeller.

Note: Make sure to note the orientation of the impellers as you remove them for later in the assembly.

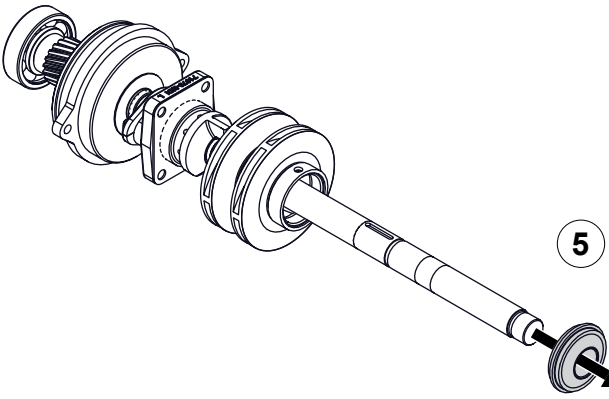
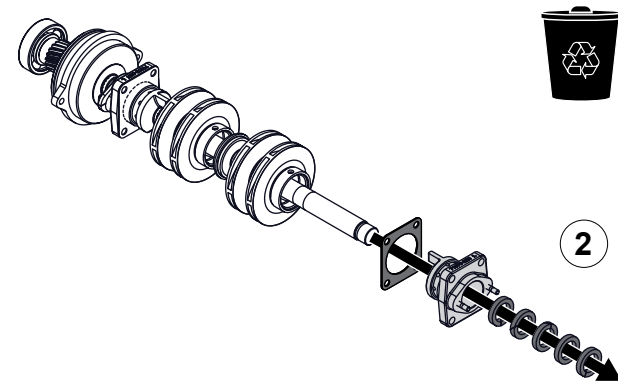

- 5 Remove the interstage seal.
- 6 Remove the retaining ring.

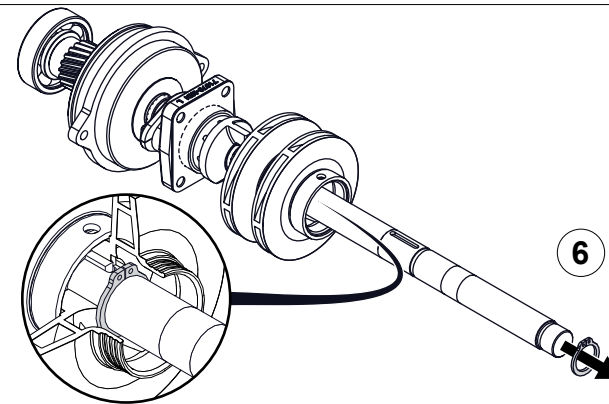
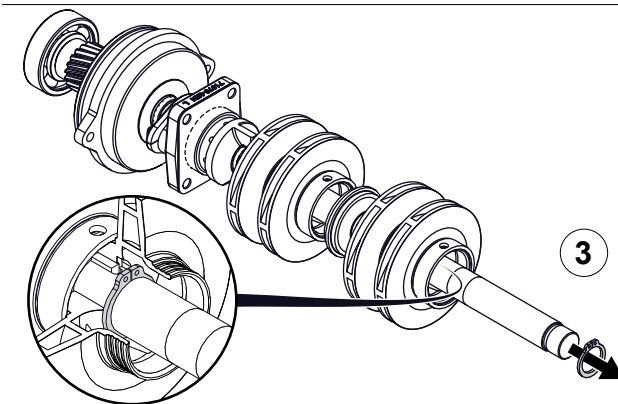

Removing the Impeller Shaft Components

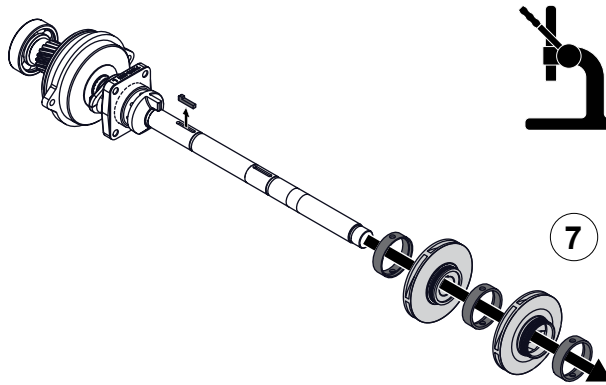

Use the illustrations and instructions to disassemble the impeller shaft.

- 7 Use an arbor press to remove the wear rings and impellers up to the packing housing. Remove the key after removing the second impeller.
- 8 Discard the gasket, then remove the packing housing, packing rings, gland halves, and hardware.
- 9 Remove the flinger ring.
- 10 Remove the hardware, bearing, driven gear, bearing spacer, and key.
- 11 Remove the bearing housing.

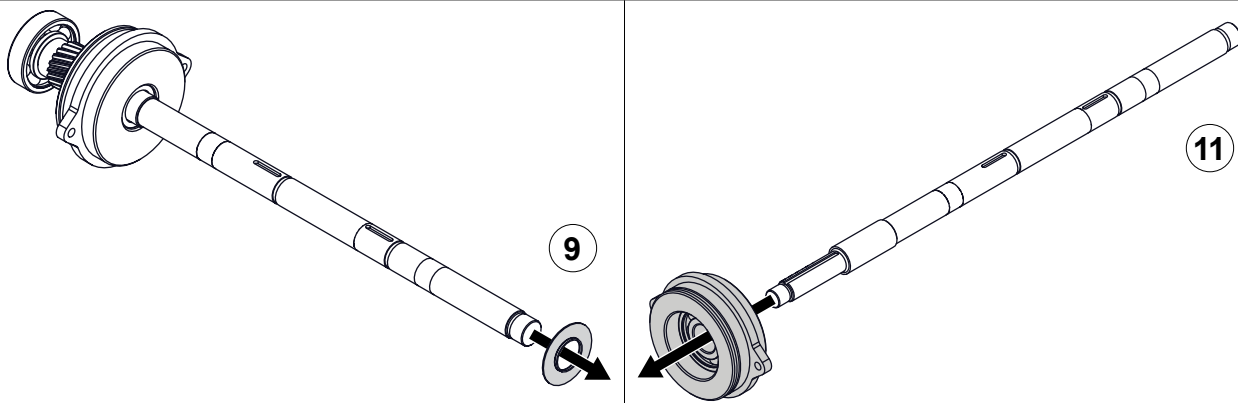
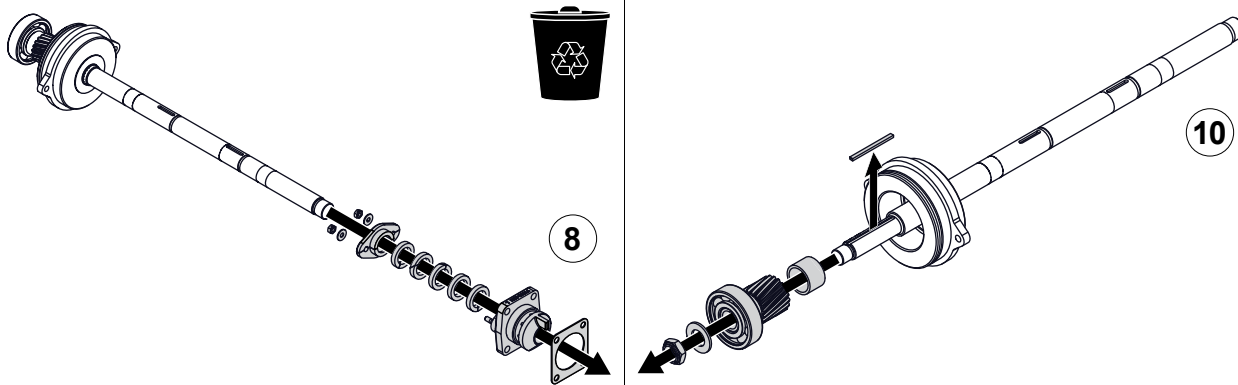

Preparing to Assemble the Pump

- Read and understand the instructions before assembling the pump.
- Prepare a workspace suitable to accommodate and support the pump.
- Gather the necessary tools and assembly aids.
- Gather the necessary overhaul components, such as lubricant, bearings, seals, and O-rings—only use equivalent components.
- Understand that your configuration may require additional steps that are not described in the illustrations or instructions to perform the assembly.
- This equipment is intended to be assembled by a person or persons with the basic knowledge of servicing similar equipment. Contact Waterous for more information.

Tools Required

- Typical automotive mechanics hand tools.
- Suitable arbor press.
- Torque wrench capable of 200 ft-lb (271 N·m).
- Suitable support and lifting equipment.

Best Practices

- Remove any dirt, sand, grease, or oil from the enclosure before you begin the assembly. Surface debris can transfer into the pump interior and prematurely wear internal parts.
- Replace any gaskets and O-ring seals during the assembly.
- Do not reuse the self-locking nuts.
- Apply anti-seize to the self-locking nut threads before installation.

Optional Equipment

Be aware that the assembly instructions may include optional equipment not included in your application.

Assembling the Pump Components

- Refer to the service parts list (SPL) for part identification.
- The SPL specific to your application is determined by the following:
 - The transmission drive method.
 - Whether the transmission drives a CAFS compressor.

Note: Documents specific to your application are available through the MyWaterous login at [Waterousco.com](https://www.waterousco.com) by entering the serial number for your system. Depending on the application, the serial number for your equipment is located on the operator panel, pump, transmission, or some combination of the three.

- Use established industry practices to assemble the pump.
- Tighten hardware to industry standard torque specification—unless otherwise noted.
- Make sure that you do not over-tighten plugs.
- Install retaining rings with the rounded face toward the component you are retaining.
- Replace items such as O-rings, bearings, gaskets, oil seals, lubricants, and locknuts with their equivalent.

Installing the Pump

Use the information that you recorded when you removed the equipment to install it into the apparatus.

Understanding the Illustrations

The assembly illustrations depict a typical application. Plugs, breathers, cooling hoses, and fittings are not illustrated, as they may be in a different location on your application. Refer to the SPL for your application to identify the various plug locations.

Impeller Shaft Assembly

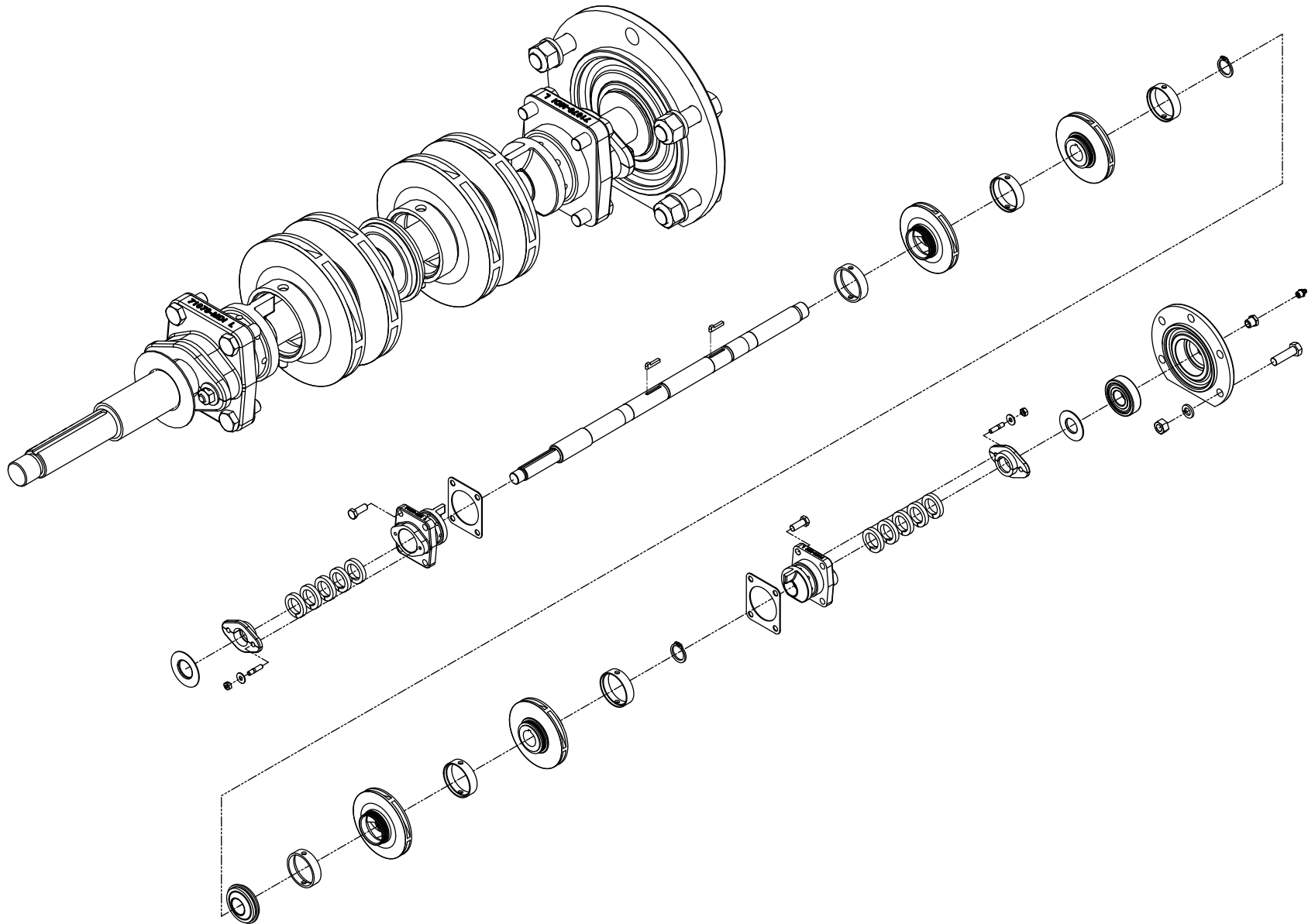

Assembling the Bearing Housing

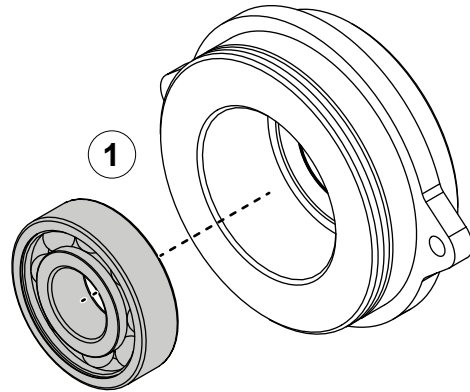
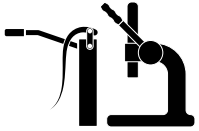

Use the illustrations and instructions to assemble the bearing housing.

- 1 Apply grease to the bearing, then press it into the bearing housing.
- 2 Apply lubricant to the O-ring groove, then install the O-ring around the bearing housing.
- 3 Apply silicon sealant around the oil seal, then install it into the bearing housing.

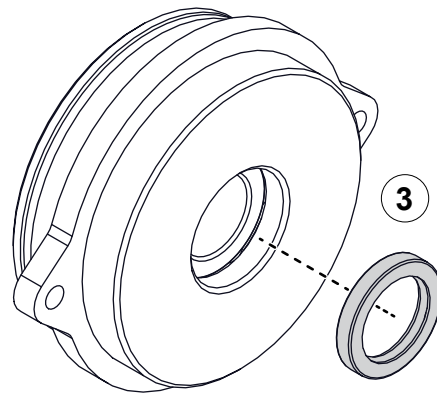
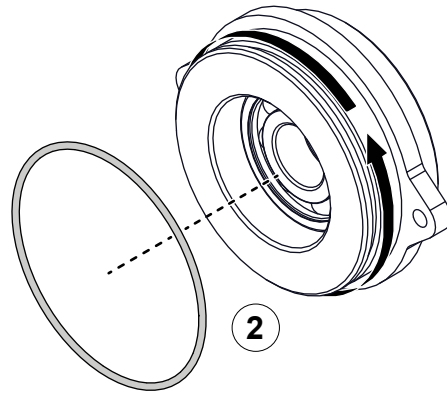

Assembling the Impeller Shaft

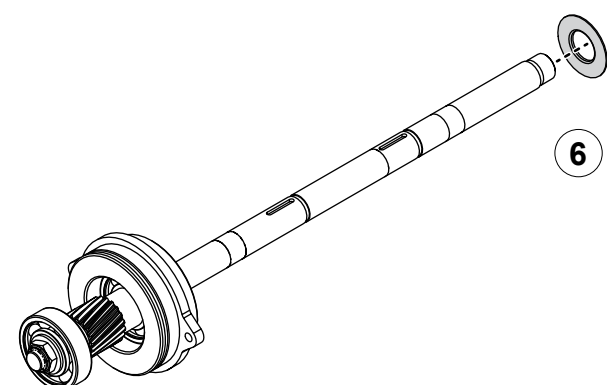
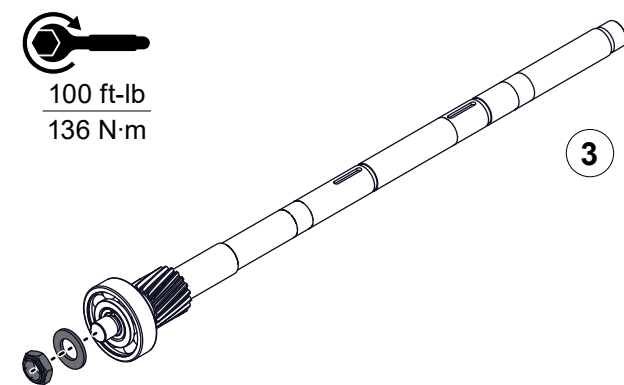
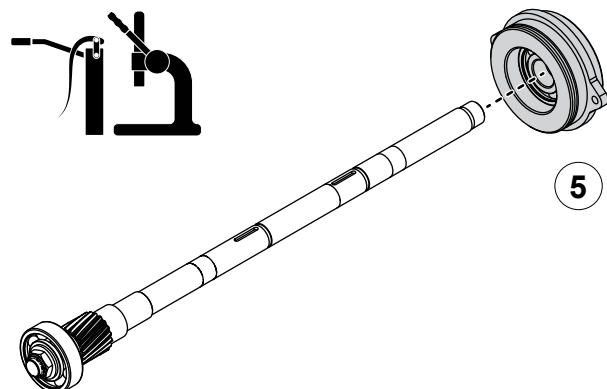
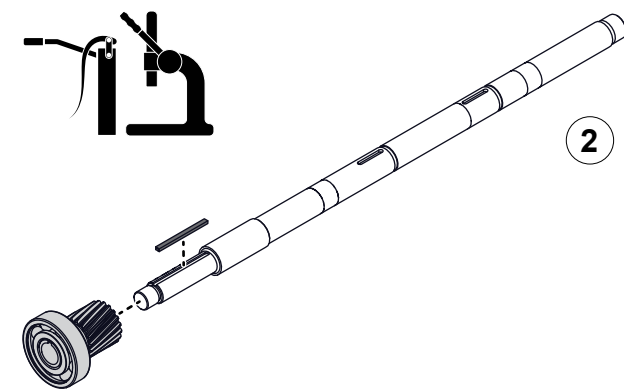
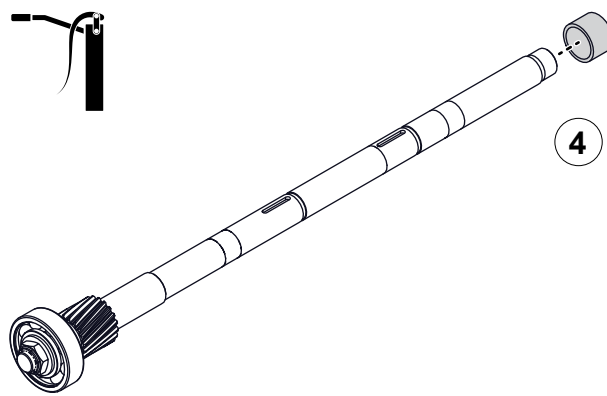
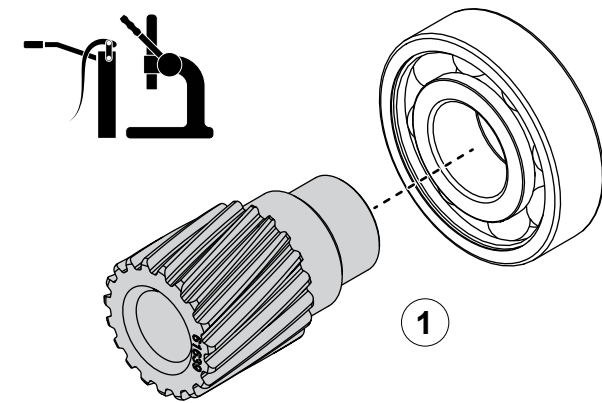

Use the illustrations and instructions to assemble the impeller shaft.

- 1 Apply grease to the driven gear, then press it into the bearing.
- 2 Insert the key into the keyway. Apply grease to the shaft, then press the driven gear onto the shaft.
- 3 Install the washer and locknut onto the end of the shaft, then tighten the locknut.
- 4 Apply grease to the shaft, then install the bearing spacer onto the shaft.
- 5 Apply grease to the bearing, then press the bearing housing onto the shaft.
- 6 Install the flinger ring onto the shaft with the rounded edge toward the bearing housing.

Note: The flinger ring should sit 1/16 inch (1.5875 mm) from the edge of the inner shoulder.

100 ft-lb
136 N·m

Assembling the Impeller Shaft

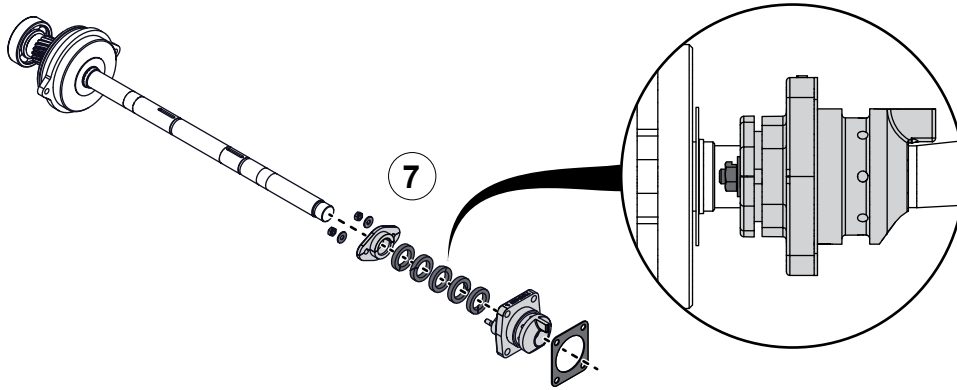

Use the illustrations and instructions to assemble the impeller shaft.

- 7 Install the gland halves, packing rings, packing housing, and gasket onto the shaft, then secure them with the hardware that you removed earlier.

Refer to: **"Installing and Tightening the Packing" on page 27.**

- 8 Use an arbor press to install the wear rings and impellers onto the shaft in the reverse order you removed them. Insert the key into the keyway before installing the first impeller.

- 9 Install the retaining ring onto the shaft.

- 10 Install the interstage seal onto the shaft.

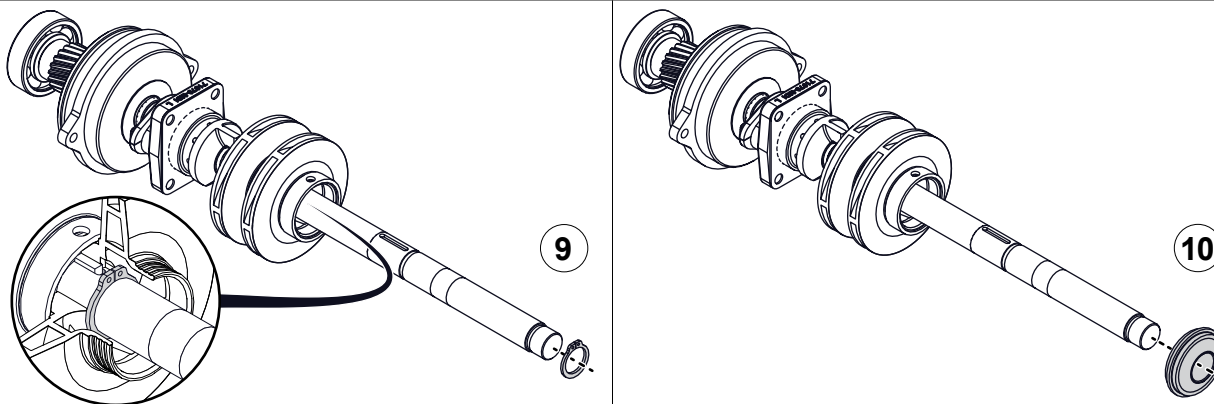
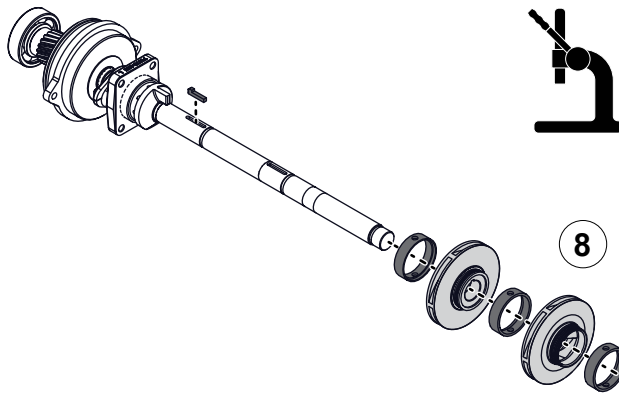

Assembling the Impeller Shaft

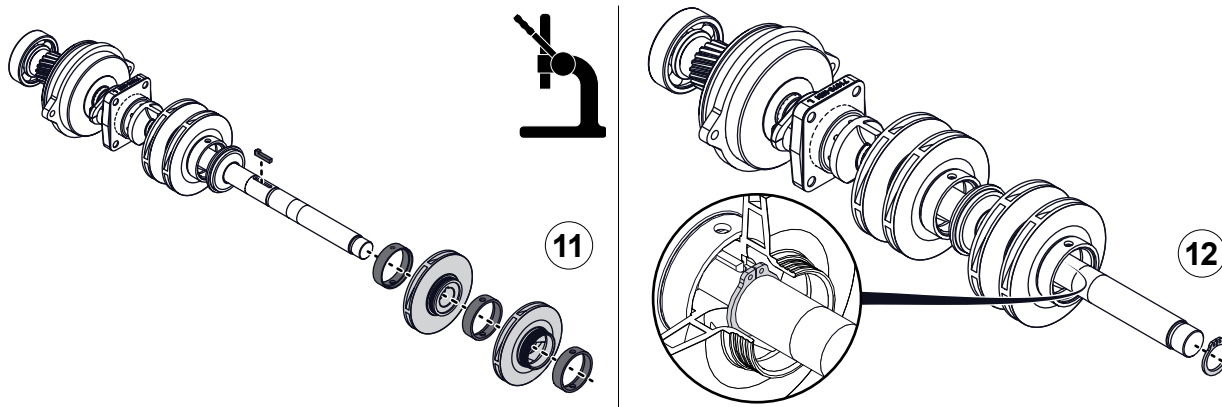

Use the illustrations and instructions to assemble the impeller shaft.

- 11 Use an arbor press to install the wear rings and impellers onto the shaft in the reverse order you removed them. Insert the key into the keyway before installing the first impeller.
- 12 Install the retaining ring onto the shaft.
- 13 Install the gasket, packing housing, and packing rings onto the shaft.
Refer to: **"Installing and Tightening the Packing" on page 27.**
- 14 Install the gland halves onto the packing housing studs, then secure them with the hardware that you removed earlier.
Refer to: **"Installing and Tightening the Packing" on page 27.**

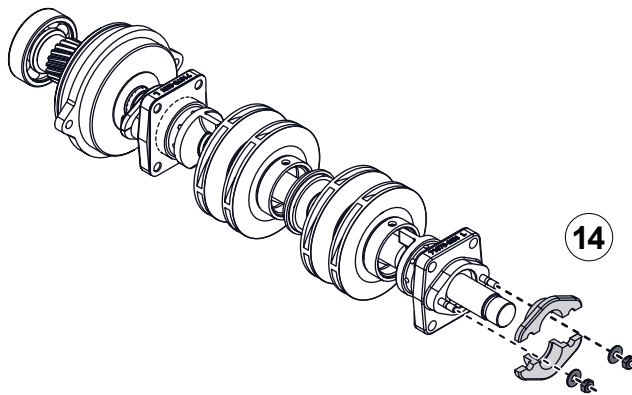
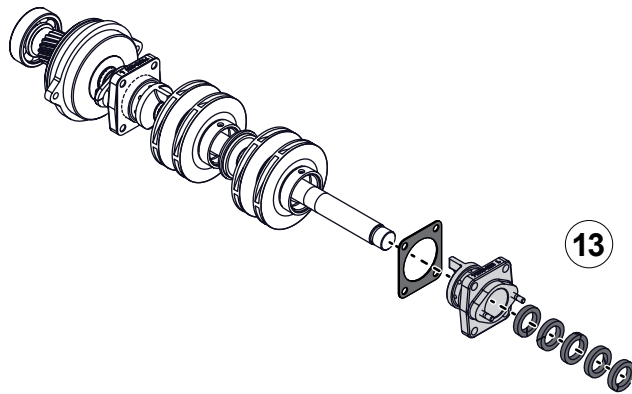

Installing and Tightening the Packing

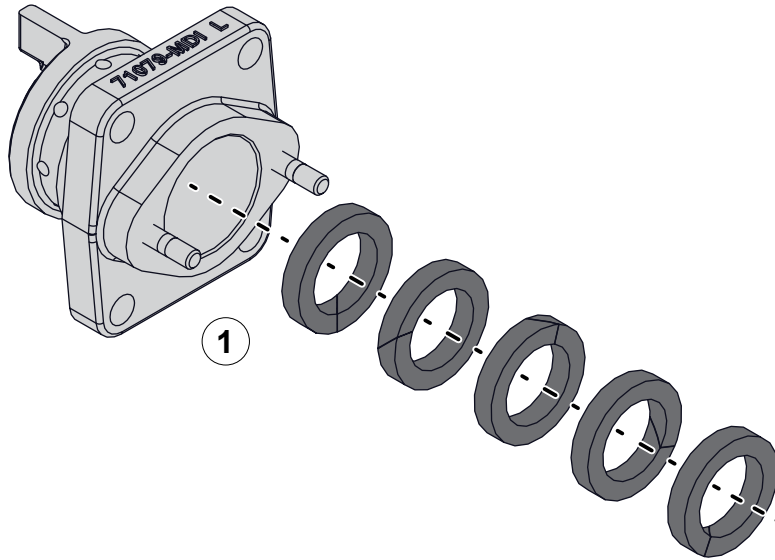

Use the illustrations and instructions to install and tighten the packing.

- 1 When installing the packing rings, stagger the joints so that they are 90° apart.
- 2 To properly set the gland, do the following:
 - Install the nuts onto the packing housing studs so that the milled slots are facing the gland.
 - Finger-tighten the nuts, alternating between them to make sure that the gland stays level.
 - Use a wrench to tighten the nuts one additional turn.

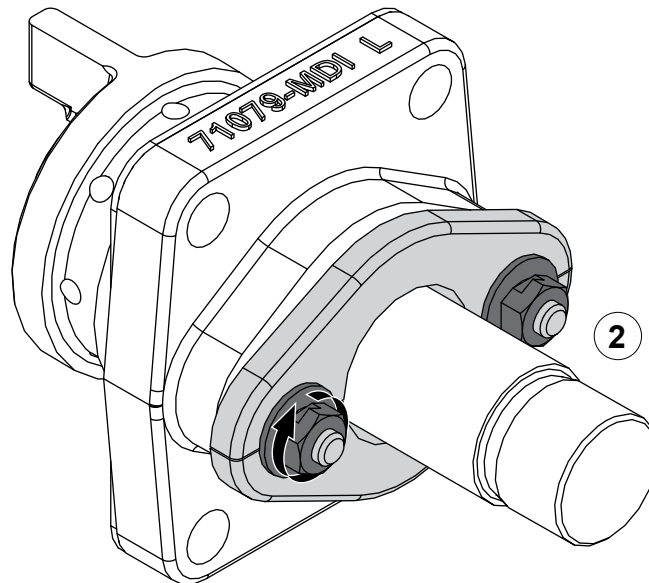

Pump Body Assembly

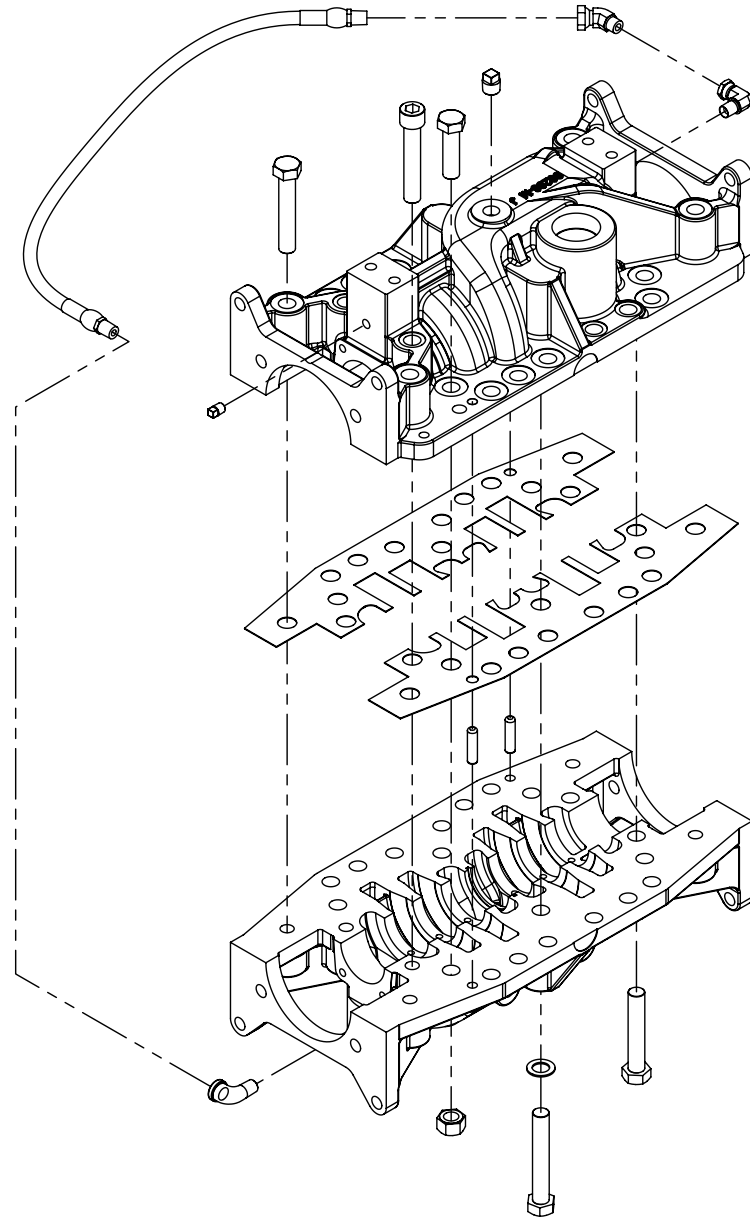
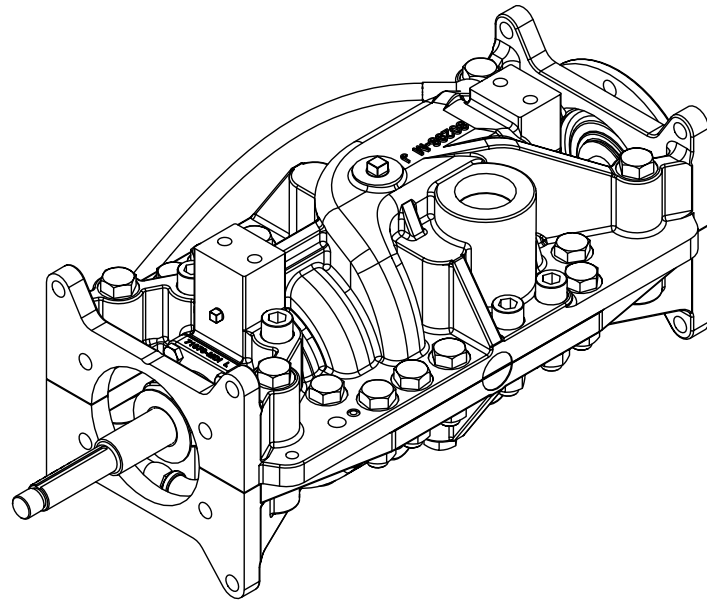

Installing the Impeller Shaft Assembly

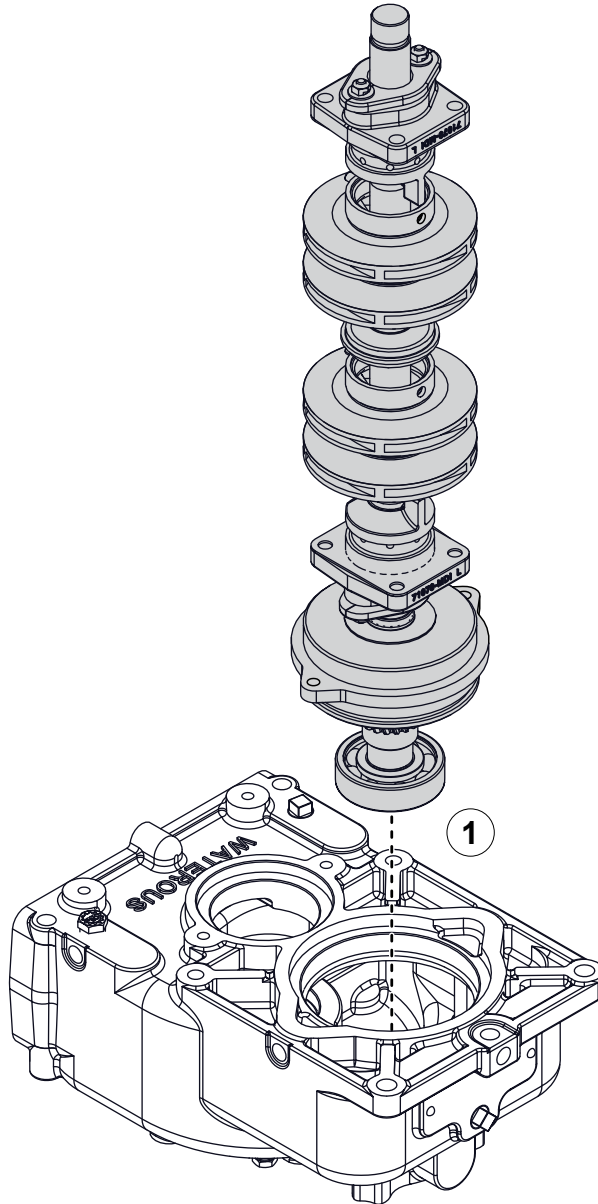
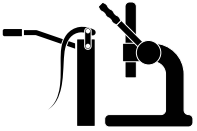

Use the illustrations and instructions to install the impeller shaft assembly.

- 1 Apply grease to the bearing, then press the impeller shaft assembly into the transmission case.

Installing the Lower Pump Body

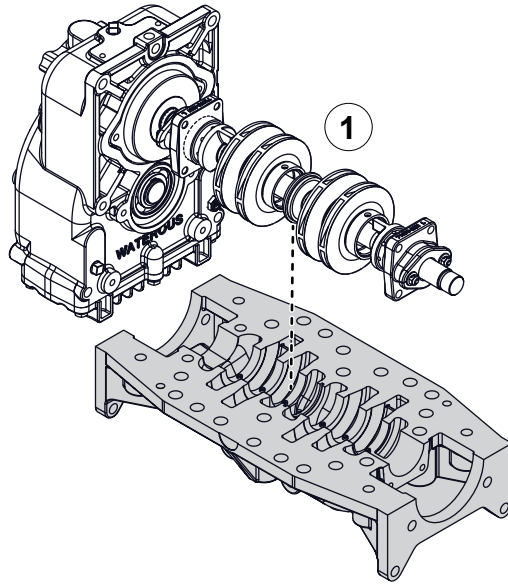

Use the illustrations and instructions to secure the lower pump body to the transmission case.

- 1 Align the lower pump body with the impeller shaft assembly.
- 2 Use the threaded studs that you removed earlier to secure the lower pump body to the transmission case.
- 3 Loosely install the washers and nuts that you removed earlier onto the studs.

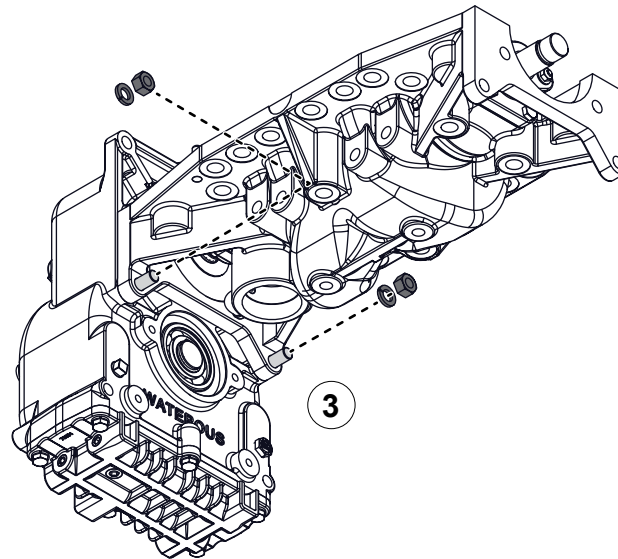
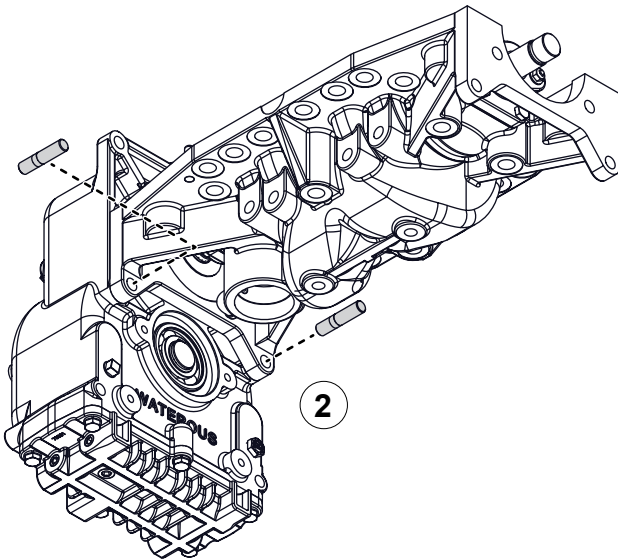

Installing the Bearing Cover

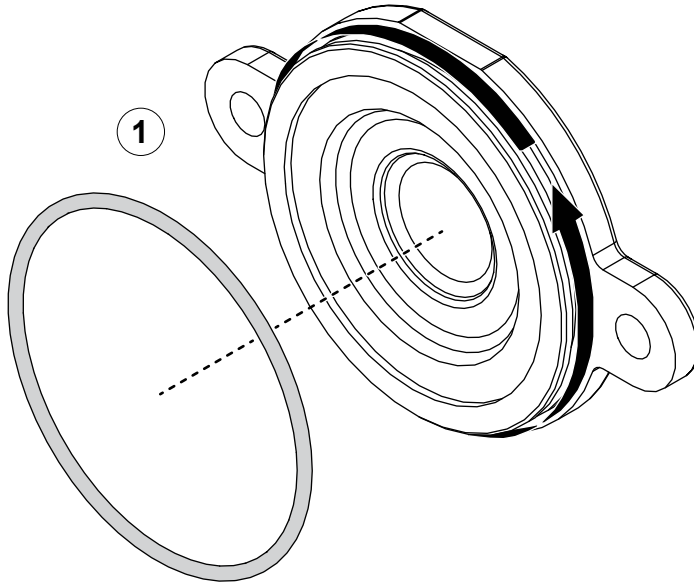

Use the illustrations and instructions to install the bearing cover.

- 1 Apply lubricant to the O-ring groove, then install the O-ring around the bearing cover.
- 2 Use the hardware that you removed earlier to secure the bearing cover to the transmission case.

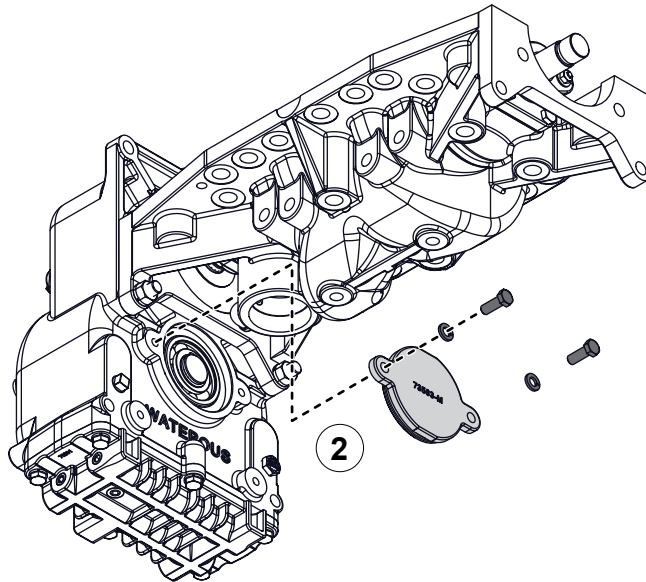

Installing the Upper Pump Body

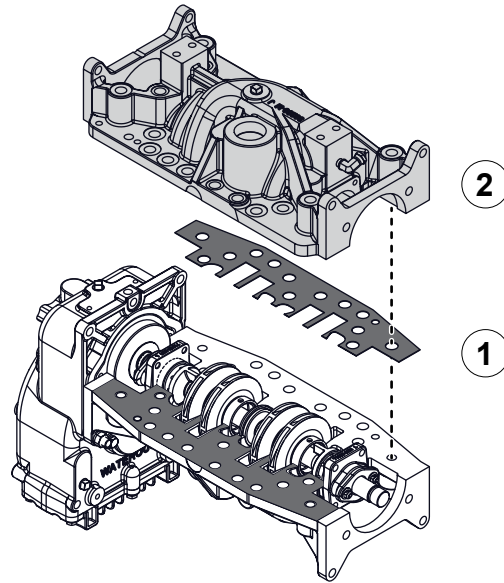

Use the illustrations and instructions to install the upper pump body.

- 1 Remove any remaining gasket material, then align the new gaskets with the lower pump body.
- 2 Align the upper pump body with the lower pump body.
- 3 Use the dowel pin that you removed earlier to connect the pump bodies.
- 4 Use the dowel pin that you removed earlier to connect the pump bodies.

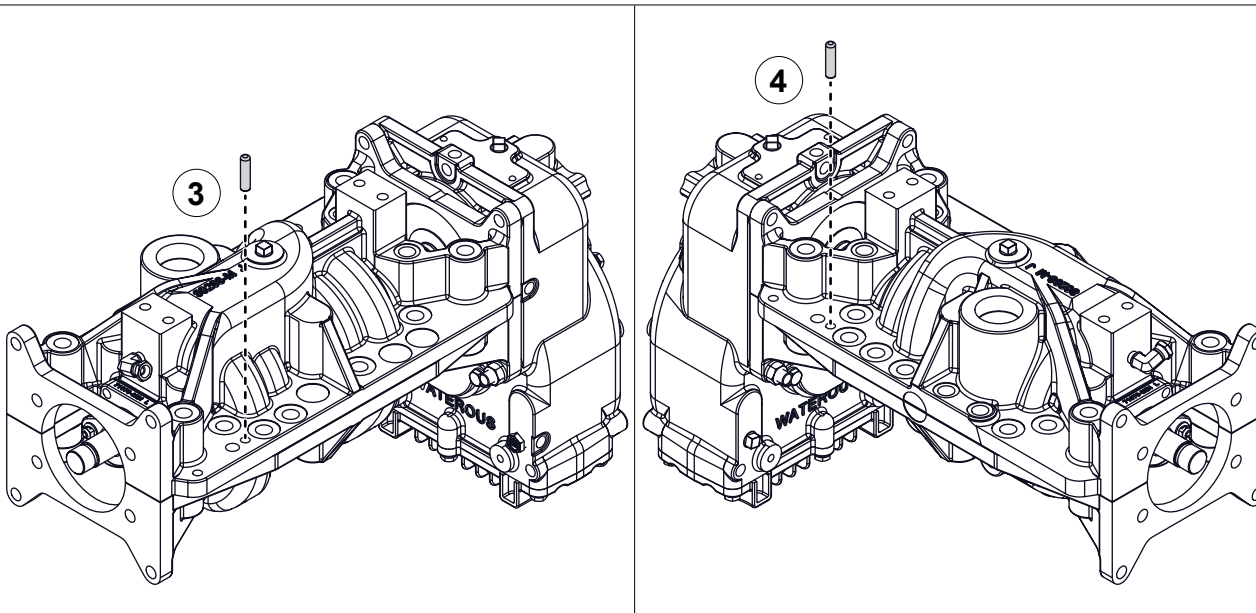

Installing the Upper Pump Body

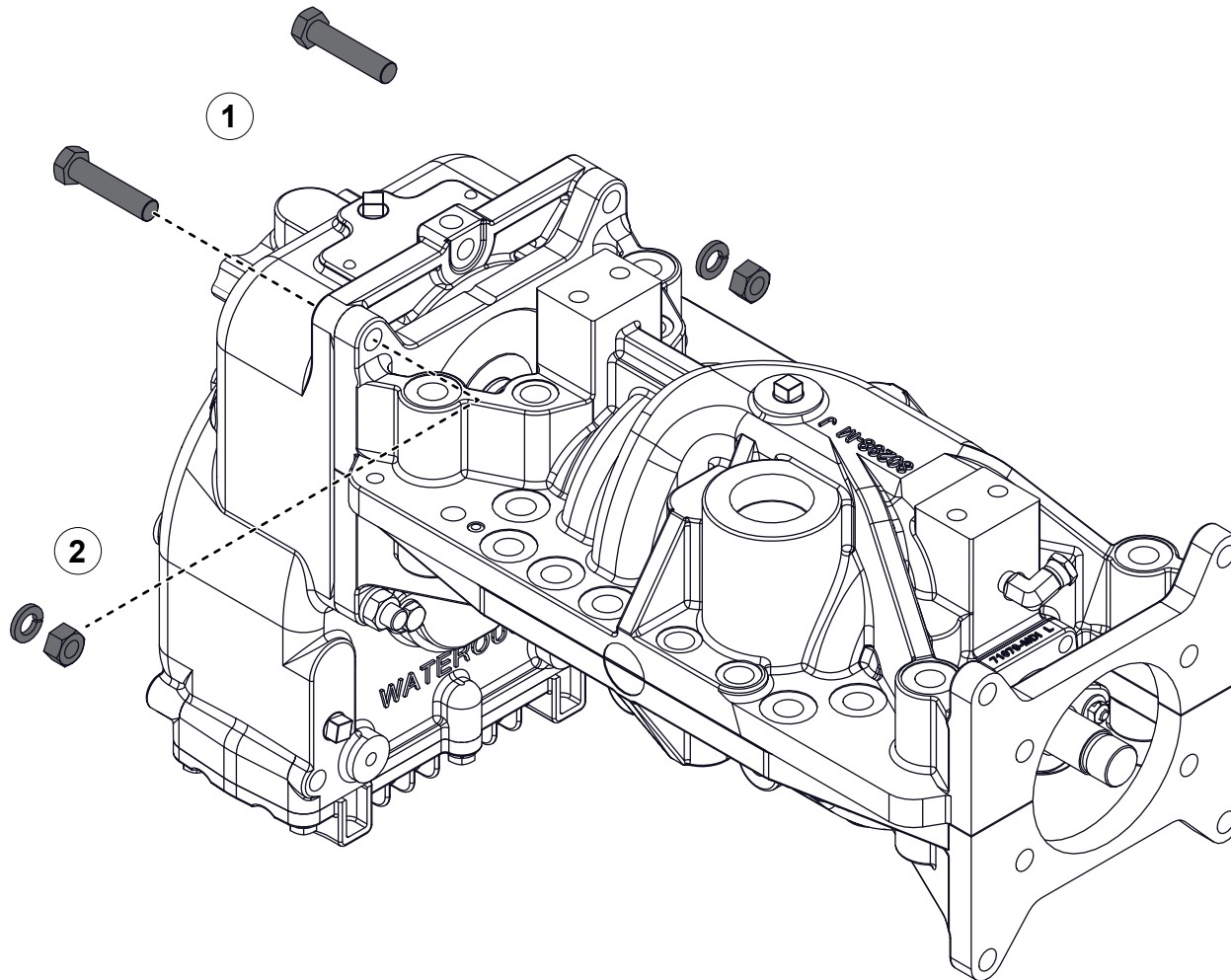

Use the illustration and instructions to install the upper transmission mounting hardware.

- 1 Use the screws that you removed earlier to secure the upper pump body to the transmission case.
- 2 Loosely install the washers and nuts that you removed earlier onto the screw threads.

Installing the Pump Body Hardware



200 ft-lb
271 N·m

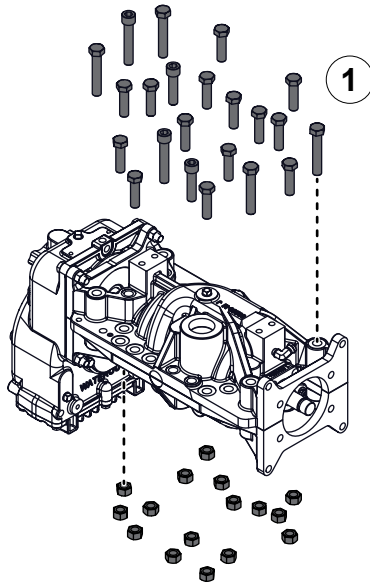

Use the illustrations and instructions to install the upper and lower pump body hardware.

- 1 Use the hardware that you removed earlier to secure the upper pump body to the lower pump body.
- 2 Use the hardware that you removed earlier to secure the lower pump body to the upper pump body.
- 3 Tighten the transmission mounting hardware.



200 ft-lb
271 N·m

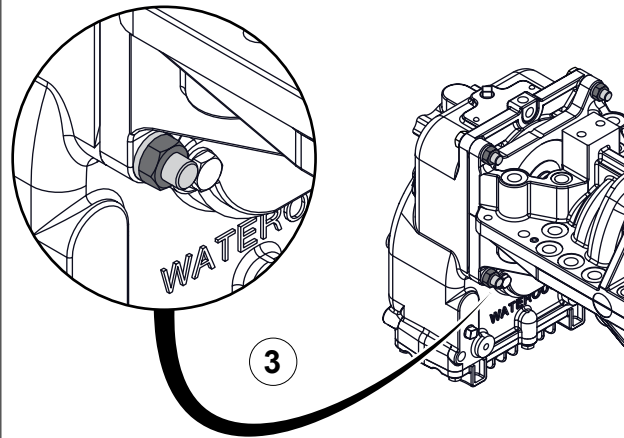
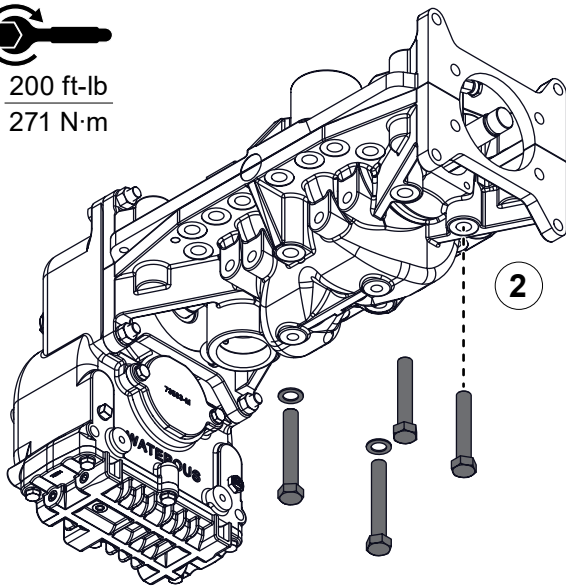

Installing the Packing Housing Hardware

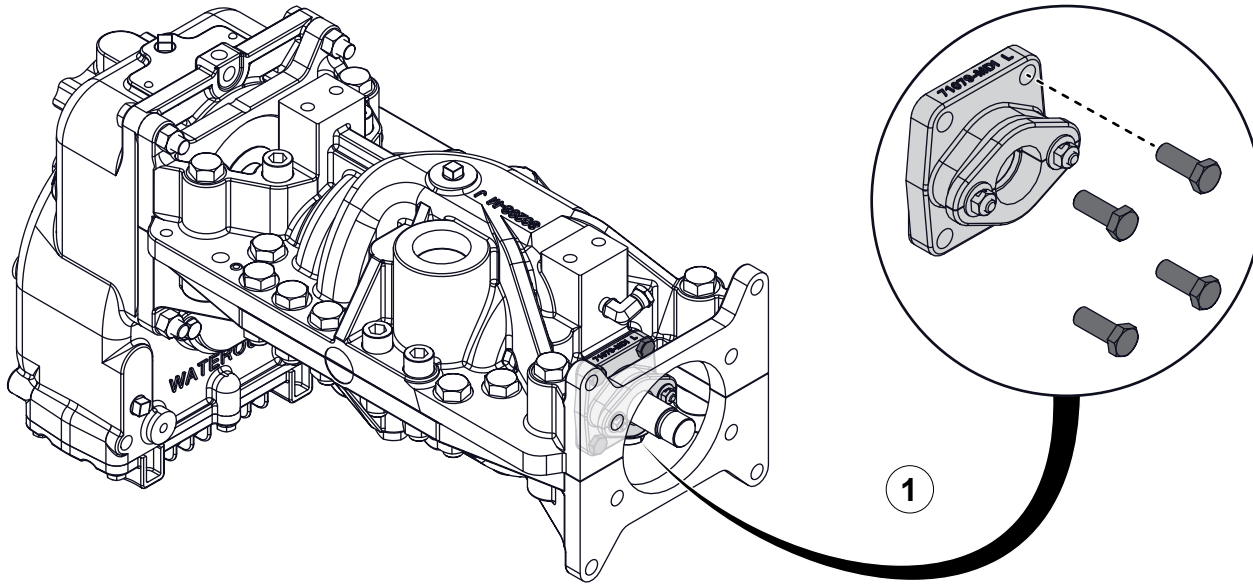

Use the illustrations and instructions to install the packing housing hardware.

- 1 Use the hardware that you removed earlier to secure the packing housing to the pump.
- 2 Use the hardware that you removed earlier to secure the packing housing to the pump.

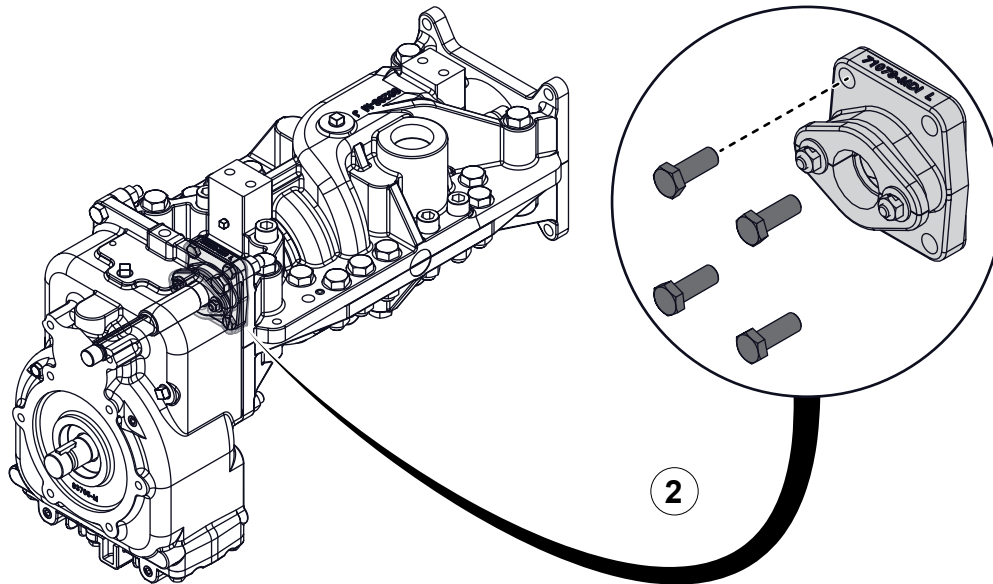

Installing the Flinger Ring and Bearing

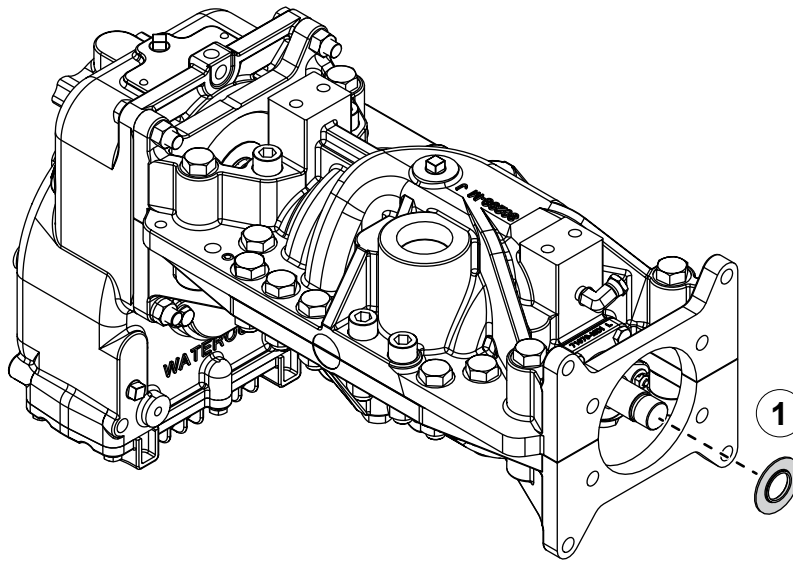

Use the illustrations and instructions to install the flinger ring and bearing.

- 1 Install the flinger ring onto the shaft with the rounded edge toward the packing housing.

Note: The flinger ring should sit flat against the edge of the impeller shaft groove.

- 2 Apply grease to the bearing, then press it onto the shaft.

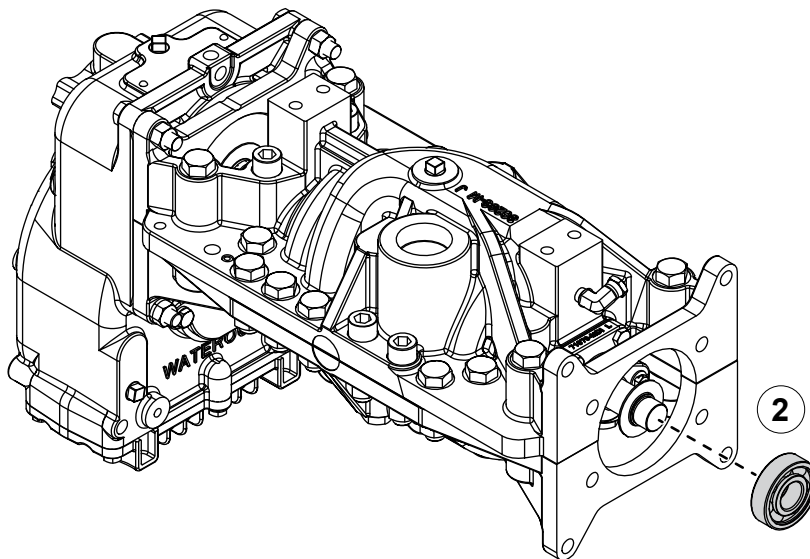
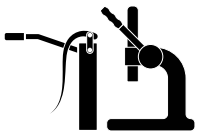

Installing the Bearing Housing

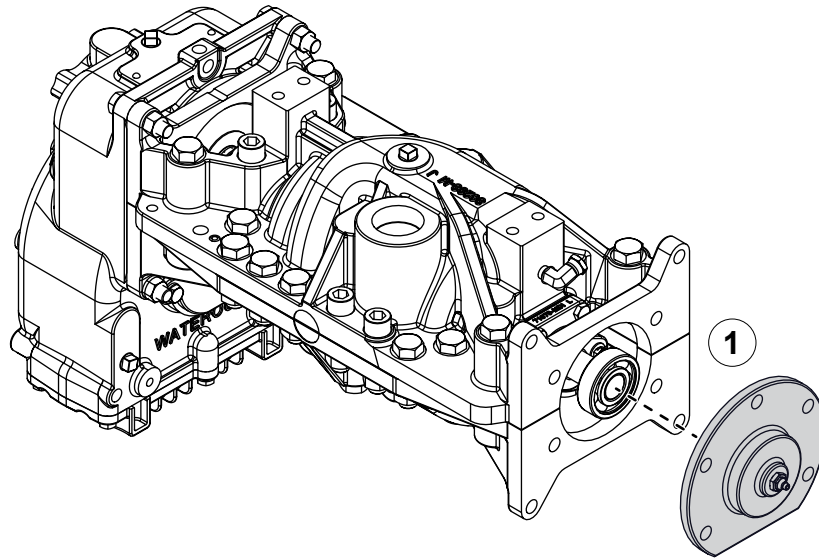

Use the illustrations and instructions to install the bearing housing.

- 1 Align the bearing housing with the pump.
- 2 Use the hardware that you removed earlier to secure the bearing housing to the pump.

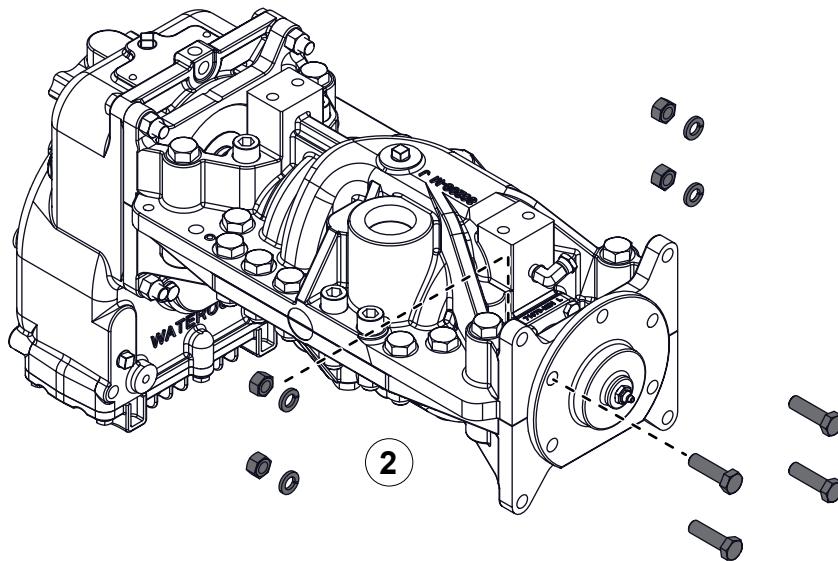

Installing the Packing Cooler Hose

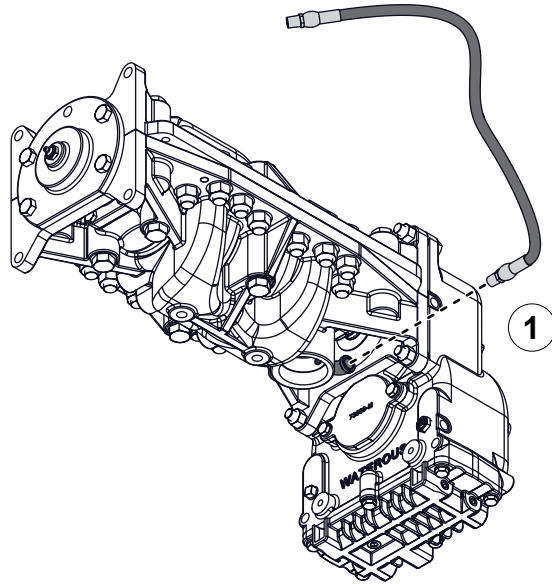

Use the illustrations and instructions to install the packing cooler hose.

- 1 Insert one end of the hose into the pump intake fitting.
- 2 Insert the other end of the hose into the upper pump body fitting.

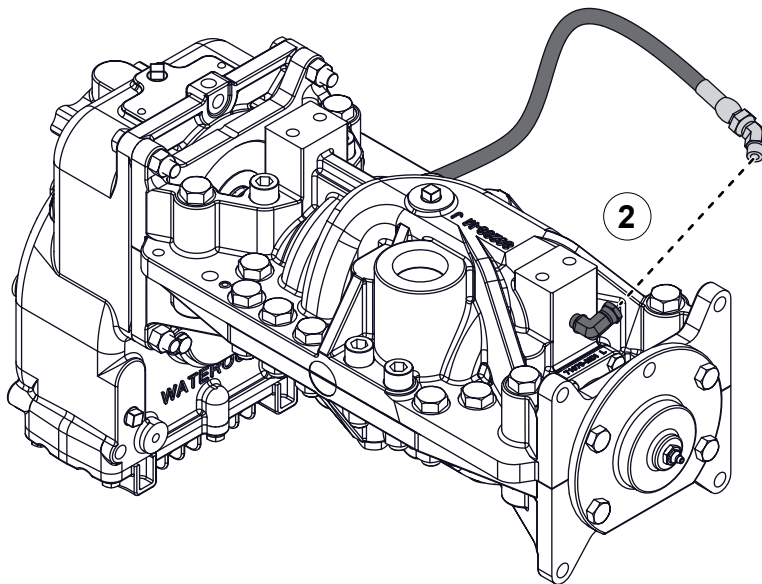

Testing After Installation

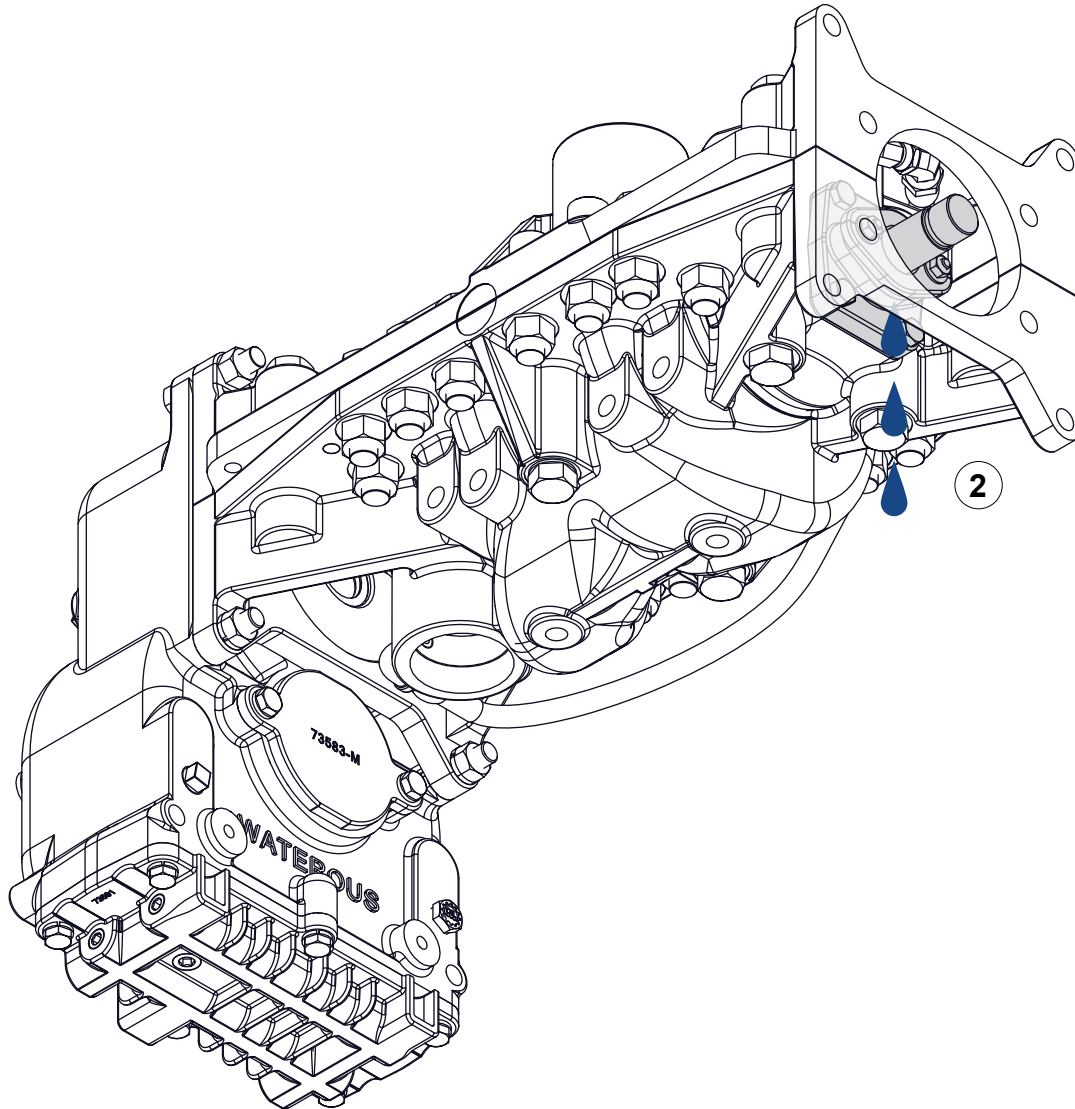

Use the illustration and instructions to adjust the packing after installing the pump into the apparatus.

Note: *Certain parts have been removed from the illustration to provide a clear view of the equipment being tested.*

- 1 Operate the pump at its maximum intended pressure for 10 minutes.
- 2 Observe the drip rate. Optimal leakage is 10 to 120 drops per minute. Maintaining this rate facilitates the cooling of the packing.
- 3 If the drip rate is too high, turn off the pump and gradually tighten the gland nuts, alternating between them to make sure that the gland stays level.
- 4 Operate the pump at its maximum intended pressure for 2 minutes. Observe the drip rate, then repeat the previous step until leakage is within the optimal range.
- 5 Repeat the process with the packing housing at the other end of the pump.
- 6 Make sure that you perform all tests required by the National Fire Protection Association.

WATEROUS

Waterous Company
125 Hardman Avenue South
South Saint Paul, MN 55075
(651) 450-5000
www.waterousco.com