

Table of Contents



Read through the safety information and overhaul instructions carefully before repairing your Waterous TMR Reversing Transmission.

Introduction	2
Ordering Repair Parts	2
General Overhaul Information	3
Disassembly	4
Inspection	4
Reassembly	4
Diagrams:	
Case	6
Driveline	7
Shift Mechanism	8
Chain Connecting Pin	9
Lubrication	10
Final Checks	10

NOTE: Instructions subject to change without notice

Introduction

This instruction provides the necessary steps involved to overhaul the TMR Reversing Transmission. Note that the instructions are divided into Disassembly and Reassembly sections.

Ordering Repair Parts

Refer to Service Parts List SPL81121 furnished with your transmission for identification of individual components.

When ordering repair parts, furnish the reference number of the component (from Service Parts List) along with the transmission model and serial number.

Note that gasket and shim repair kits are available that include all the gaskets, shims and O-rings required for a complete overhaul.

Order Waterous Part Number as follows:

Driveline Size	Order Repair Kit
1-3/4 inch	K 783-1
2 inch	K 783-2

Serial Number Located on Input Shaft Side of Case

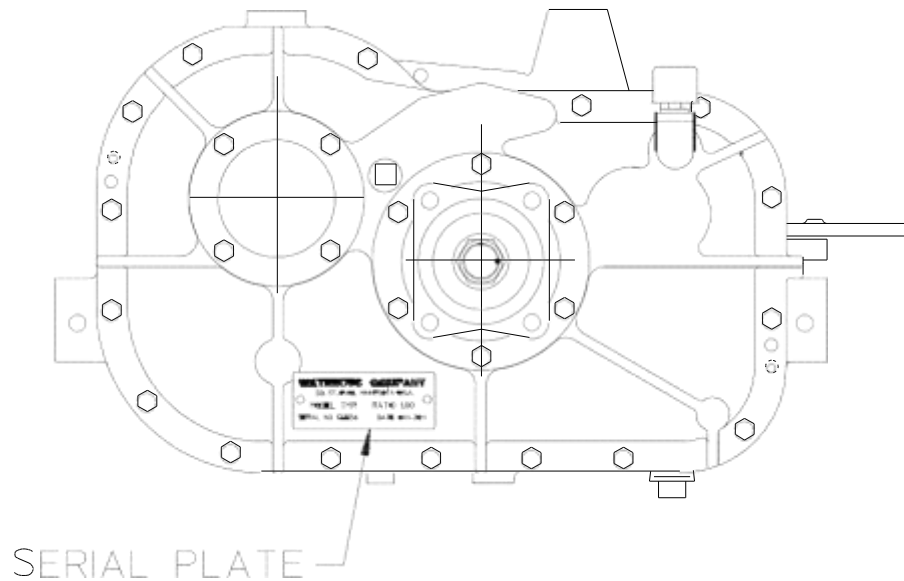

General Overhaul Information



WARNING

Rotating Parts Hazard or Unexpected Truck Movement. May result in serious personal injury or death.

Stop the engine, set parking brake and chock the wheels before attempting to remove or repair the transmission.



WARNING

Transmission Temperature Hazard. May result in serious burns.

The transmission may be warm from operation. Make sure that the transmission has cooled sufficiently prior to removal or repair.

Tools and Equipment

The following tools and equipment may be needed to overhaul your transmission:

1. Usual automotive mechanic's hand tools.
2. An arbor press for assembling or disassembling components.
3. A suitable hoist and slings.
4. Torque capability up to 325 lb-ft.

Cleaning

Satisfactory operation depends to a great extent upon the cleanliness of its internal parts. Sand, dirt or other abrasive material will wear gears and related parts. Before disassembling a transmission for repairs, be sure to clean its exterior. Make sure the working space, benches and tools are clean. Use only clean, lint-free cloths to wipe off components. Before reassembling, be sure to clean all components thoroughly.

Bearings, Gaskets, Seals and O-rings

Parts of this nature are frequently damaged during removal or disassembly. In addition, they sometimes deteriorate or lose their effectiveness because of age or misuse. Replacing these parts whenever overhauling a transmission is a good policy.

Installing Ball Bearings

Most Waterous transmissions are designed so that ball bearings fit tightly on their shafts and have relatively loose fits in the bearing housings. When mounting these bearings on shafts, always apply force to the inner races. When bearings have tight fit in the housings, and a heavy force is necessary to install them, be sure to apply force only to the outer bearing races. For either type of fit, applying force to the wrong bearing race may damage the balls and race.

End Yoke and Companion Flange Nuts

Do not reuse self-locking nuts. Apply lubrication oil to the threads before removing. Apply anti-seize to the threads before installing a new self-locking nut.

Disassembly

Note that the text below uses reference numbers when discussing specific parts. Refer to Pages 6 through 9 for diagrams identifying these parts.

1. Drain lubricant from case (see Page 10 for drain location).
2. Remove transmission from vehicle
3. Remove companion flange (T15) from both ends of transmission.
4. Remove drive shaft bearing housing (T12).
5. Remove input end section (T45A). Note that two (2) 3/8-16-UNC-2 jacking screw holes are provided.
6. Disconnect chain (T47) and remove from sprockets (T50 and T23) as follows: (See diagram on Page 9).
 - a. Remove the small roll pin in the end of connection pin.
 - b. Push the connecting pin completely through the chain towards the gear (output) end of the transmission.
 - c. Push the shorter connecting pin through the chain towards the gear (output) end of the transmission.
 - d. Separate ends of the chain (T47) and remove from sprockets (T50 and T23).
7. Remove both bearing covers (T7 and T67) on output on output end of transmission.
8. Pull countershaft assembly (T57) from center section of case (T45B).
9. Pull drive shaft assembly (T17) from center section of case (T45B).
10. Remove output end section of case (T45C) from three-piece case (T45). Note that two (2) 3/8-16 UNC-2 jacking screw holes are provided.
11. Pull coupling shaft assembly (T62) from center section of case (T45B).
12. Note the arrangement of the internal shift components in center section of case (T45B) before removal, then proceed as follows:
 - a. Remove spirol pin (T34) which connects sector gear (T31) to the shift shaft (T39).
 - b. Pull shift shaft (T39) out of the center case section of case (T45B).
 - c. The remaining shift mechanism components can now be removed.
13. Disassemble counter shaft assembly (T57), drive shaft assembly (T17) and coupling shaft assembly (T62) as necessary for inspection and repair.

Inspection

Examine all components for signs of excessive wear or other defects and replace if necessary. Replace all bearings, seals, gaskets and any worn parts.

Reassembly

Installing Ball Bearings

Keep bearings covered until they are to be installed. Before pressing a bearing on a shaft, coat its bore with grease. Always apply force to the inner race of a ball bearing when pressing on a shaft, never the outer race. Press evenly with a piece of pipe or tube which will just clear the shaft. Be sure the shaft is clean before installing bearing.

Installing Oil Seals

Before installing an oil seal in a housing, apply a thin coat of sealant to the housing oil seal seat. Waterous recommends Loctite Ultra Blue RTV Silicone Sealant or Permatex Super 300. Be sure the seal, shaft and housing are clean. Always install

the seal with the lip facing in. Apply force to the outer edge of the seal and press in evenly.

Installing Gaskets

If a gasket is awkward to hold in place while installing, coat one of the component mating flanges with heavy grease and press the gasket into position against the flange. The grease will hold the gasket in place during reassembly.

End Yoke and Companion Flange Nuts

Do not re-use self-locking nuts. Apply lubrication oil to the threads before removing. Apply anti-seize compound to the shaft threads before installing a new self-locking nut.

Reassembly Steps

Note that the text below references number when discussing specific parts. Refer to Pages 6 through 9 for diagrams identifying these parts.

1. Reassemble counter shaft assembly (T57), drive shaft assembly (T17) and coupling shaft assembly (T62).
2. Install shift mechanism in center section of case (T45B). As shift arm (T41) is installed on shift shaft (T39), make sure spring (T44) is restrained in housing (T43) and is compressed sufficiently to allow pin (T42) to be installed through shift arm (T41) and into the slot in housing (T43).
3. Adjust stop screws (T69) against sector gear (T31) so that the sector gear rotates small pinion gear (T27) (locking arm assembly) just short of 180 degrees of movement from one position to the other. At mid point of travel, the arm of the locking arm assembly (T27) should point directly at the shift shaft (T39). Also make sure separate shift shoe (T26) is installed on the pin of the locking arm assembly (T27) and in the groove in the bottom of shift fork (T25).
4. Actuate the shift mechanism by moving shift arm (T41) in the direction of the output shaft end of the transmission and leave in this position until completion of Steps 5, 6 and 7.
5. Install coupling shaft assembly (T62) in the center section of case (T45B) seating inner bearing (T20) in case bore.
6. Install output end section of case (T45C) to center section of case (T45B). Note that two (2) dowel pins (T79) are used between the flanges. Fastener tightening torque 31 Ft-lb (4X).
7. Install shift collar (T51) onto shoes on shift fork (T25). Note that if the transmission was built prior to February 17, 2003, the shift collar has a chamfer on one end (see Detail A on Page 8) which must be facing the input end of the transmission.
8. Actuate the shift mechanism by moving the shift arm (T41) in the direction of the input end of the transmission and at the same time, guide the shift collar (T51) over the teeth on the end of the coupling shaft (T62).
9. Install coupling shaft bearing housing (T67) less shims (T68) on output end section of case (T46C). Loosen screws and allow cover to back off approximately 1/16 inch from the face of the case (T46C).
10. Install counter shaft assembly (T57) and bearing cover (T7) on outer end section of case (T46C). Fastener tightening torque 31 Ft-lb (4X).
11. Install drive shaft assembly (T17) and bearing cover (T7) on input end section of case (T45A). Fastener tightening torque 31 Ft-lb (4X).
12. Install chain (T47) over sprockets (T50 and T23) and mesh chain ends together. See diagram on Page 8.
13. Install chain connecting pins per diagram on Page 9.
14. Install input end section of case (T45A) on center section of case (T45B). Note that two (2) dowel pins (T78) are used between the flanges.
15. Tap drive shaft assembly (T17) and coupling shaft assembly (T62) toward the input end of the transmission. Push coupling shaft bearing cover (T67) in until it seats against the outer bearing (T20). Measure the gap between the output end section of case (T46C) and bearing cover (T67). Add a minimum of .005 in. to the measured dimension. The gap distance plus .005 in. is the correct minimum amount of shims (T68) to install between the case (T46C) and cover (T67). Remove cover (T67) and install shims (T68) and then reinstall the cover (T67). Fastener tightening torque 31 Ft-lb (4X).
16. Install companion flanges and any miscellaneous hardware previously removed.
17. Tighten companion flange self-locking nuts as follows:
 - 1-3/4 in. Drivelines: 275-325 Ft-lb.
 - 2 in. Drivelines: 475-525 Ft-lb.

Diagrams

Case Diagrams

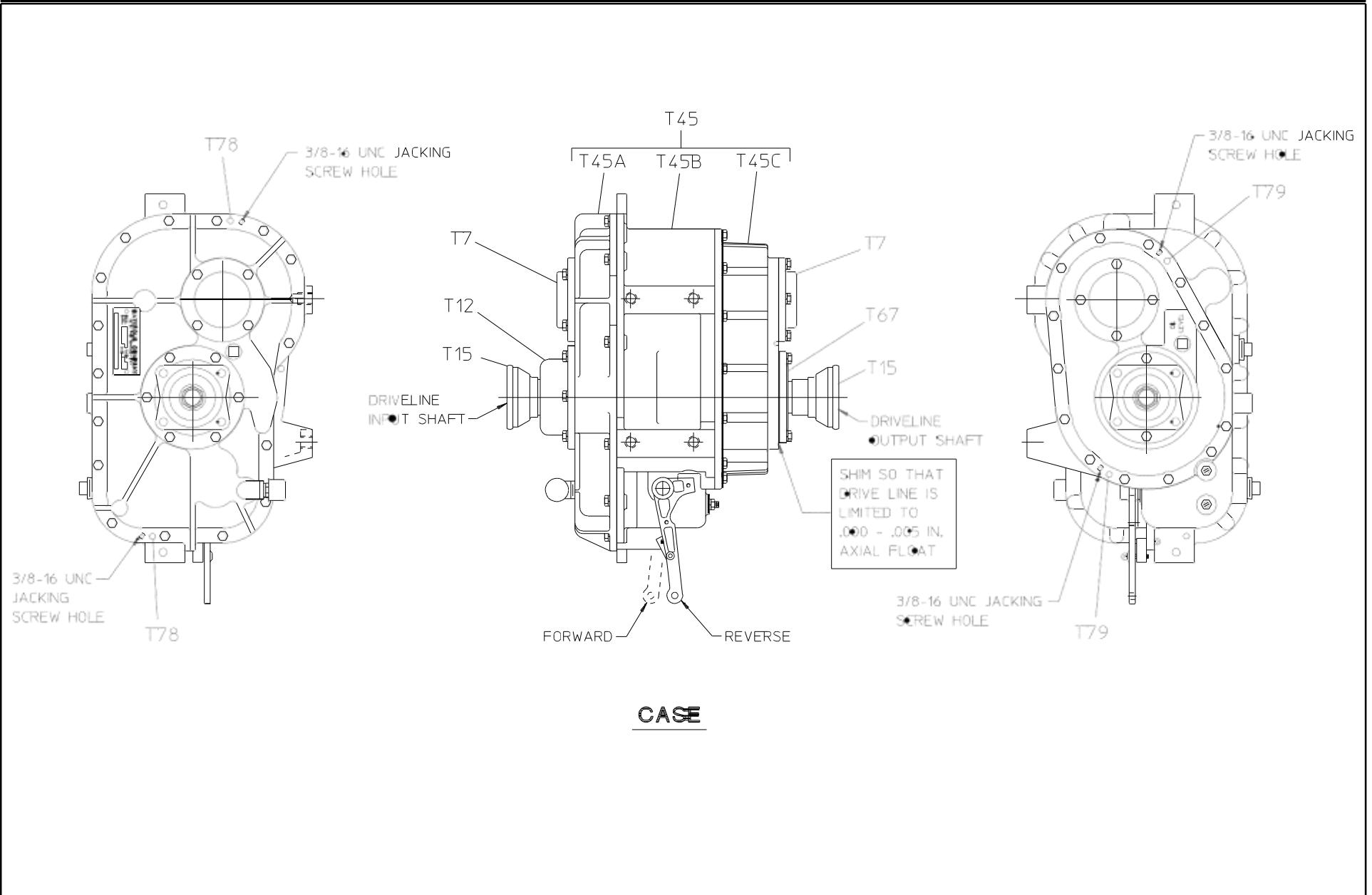

Driveline Diagram

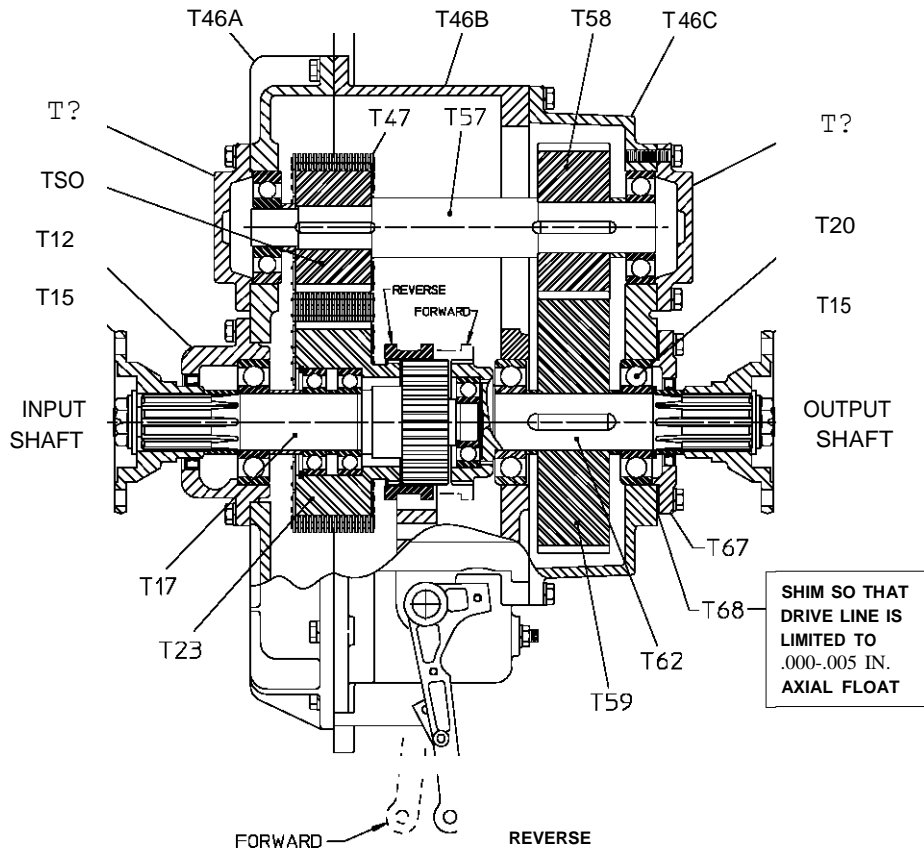

SHIM SO THAT DRIVE LINE IS LIMITED TO .000-.005 IN. AXIAL FLOAT

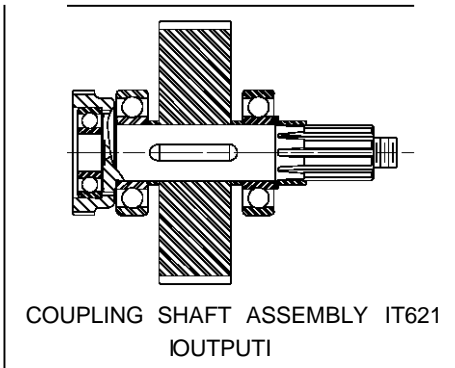
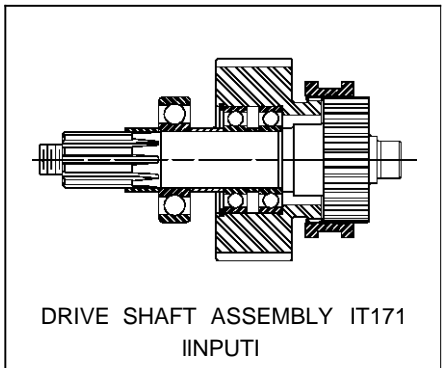
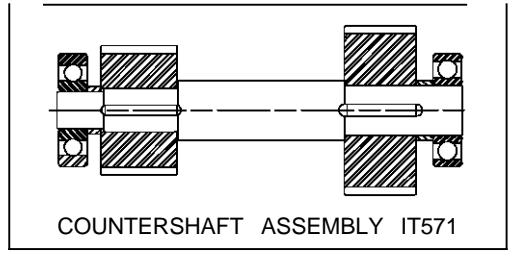

Shift Mechanism Diagram

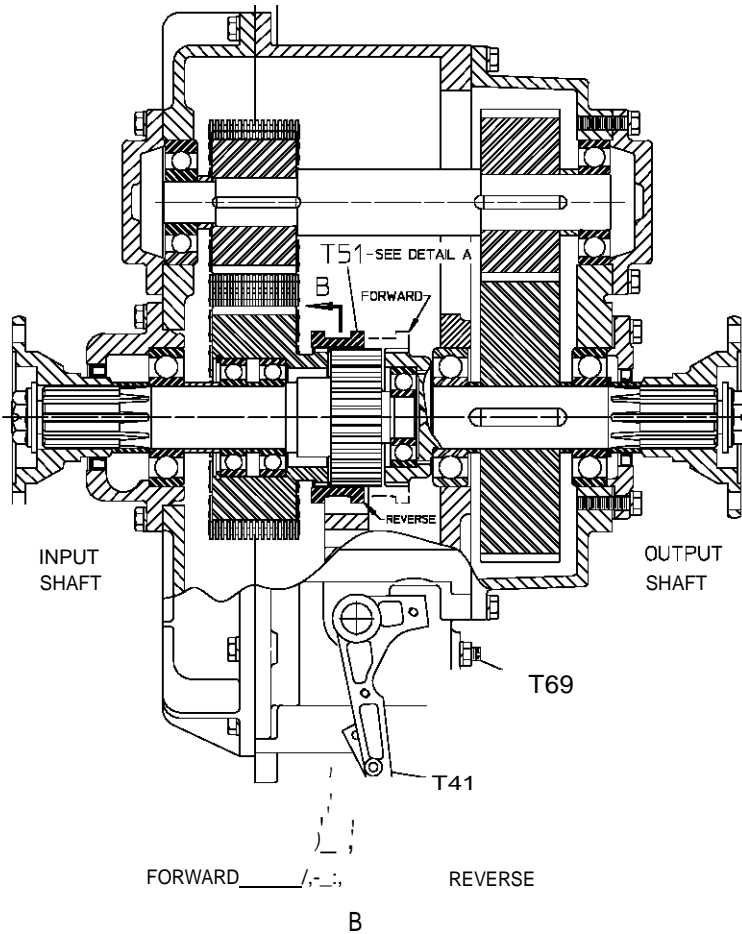

CHAMFERED END
OF SHIFT COLLAR
TO BE TOWARDS
INPUT END OF CASE

T51

DETAIL A
SHIFT COLLAR TS1 ORIENTATION
PRIOR TO FEB 17. 2003

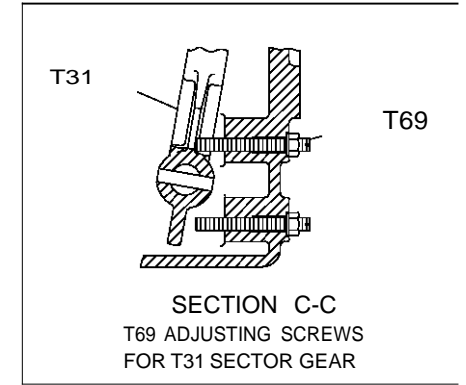
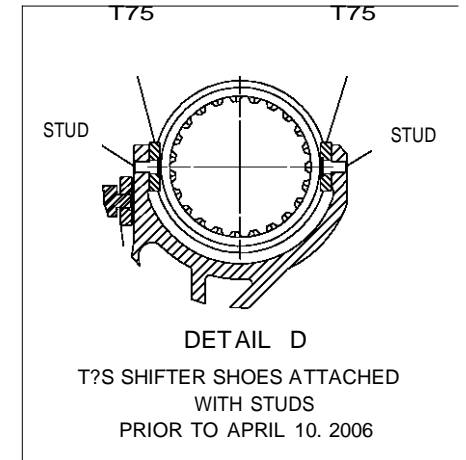
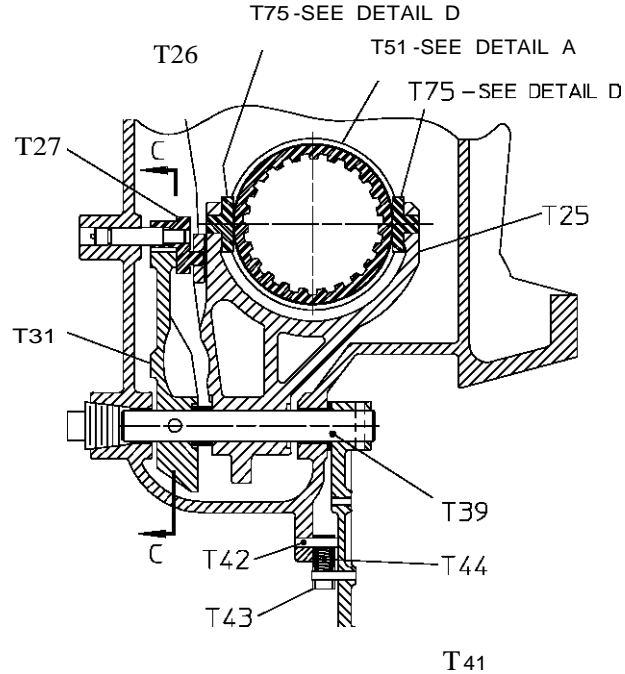

Chain Connecting Pin Diagram

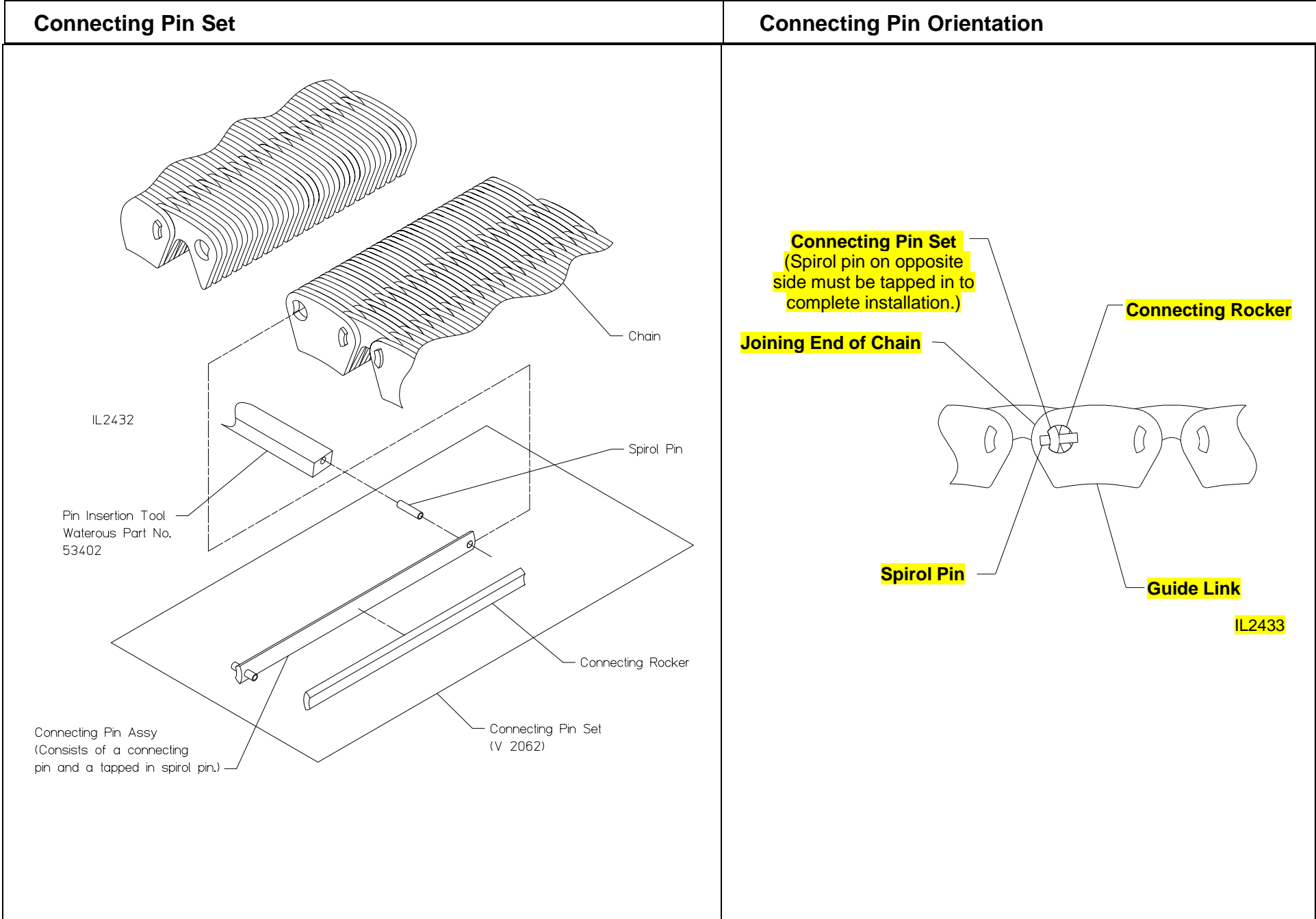

Lubrication

Lubrication

1. Fill transmission to bottom of oil plug with automatic transmission fluid. Transmission holds approximately 5 quarts.

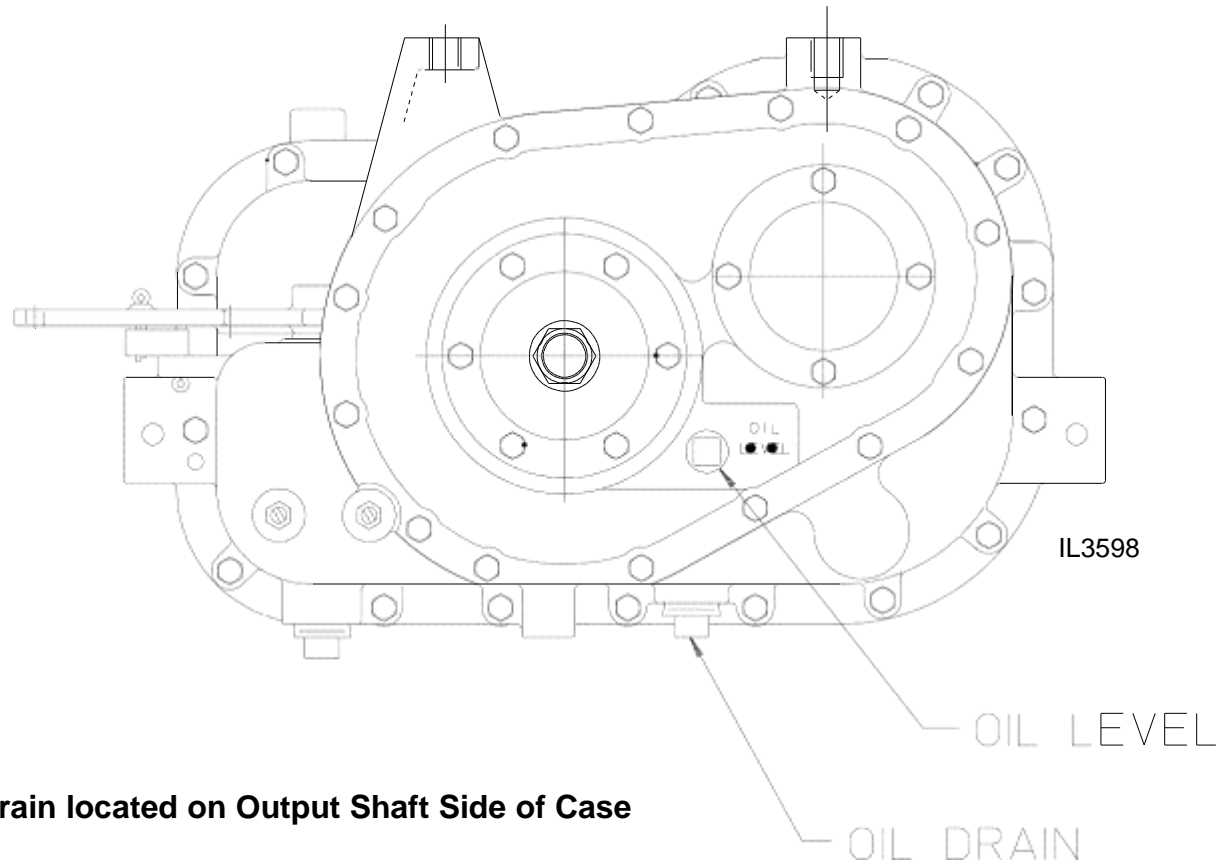

Oil Level and Drain located on Output Shaft Side of Case

Final Checks

1. Recheck all fasteners for proper tightness.
2. Check for any fluid leaks.