

Foam Pump Dimensional Drawings

Models: Aquis 1.5, Aquis 3.0 and Aquis 6.0

Component		See Page
Foam Pump	Aquis 1.5	2
	Aquis 3.0	3
	Aquis 6.0	4
OIT	Manual	5
	Digital	6, 7
Foam Concentrate	Supply Line Strainer	8
	Inject Check Valve	
	Foam Tank Level Switches	
Foam Tee (Includes Flowmeter)		9
Foam Manifold (Includes Flowmeter and Check Valve)		10
Optional Panel Plates		11
Optional Panel Mounted Foam Strainer		12
Optional Master Waterway Check Valve		See DPL83485

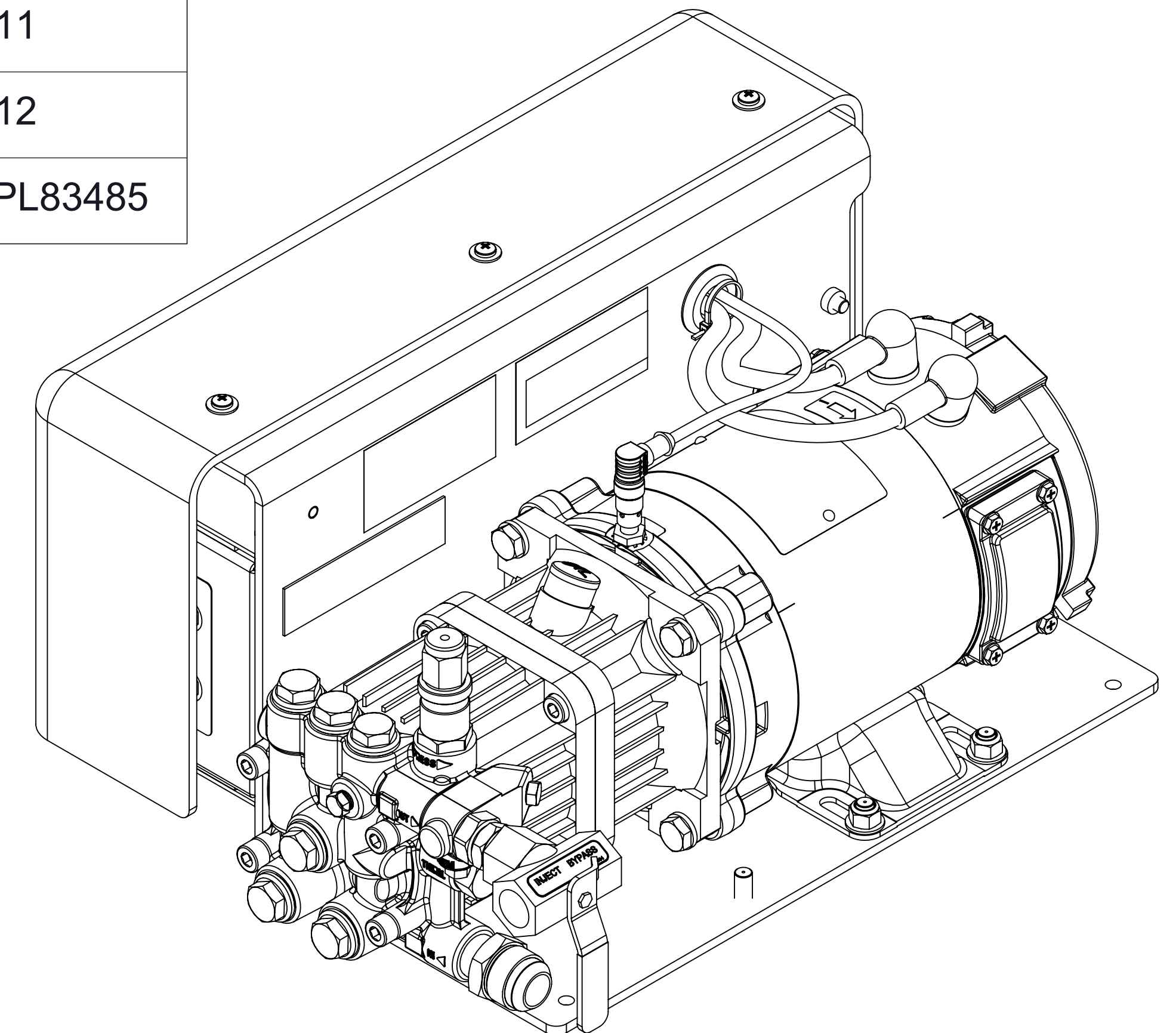

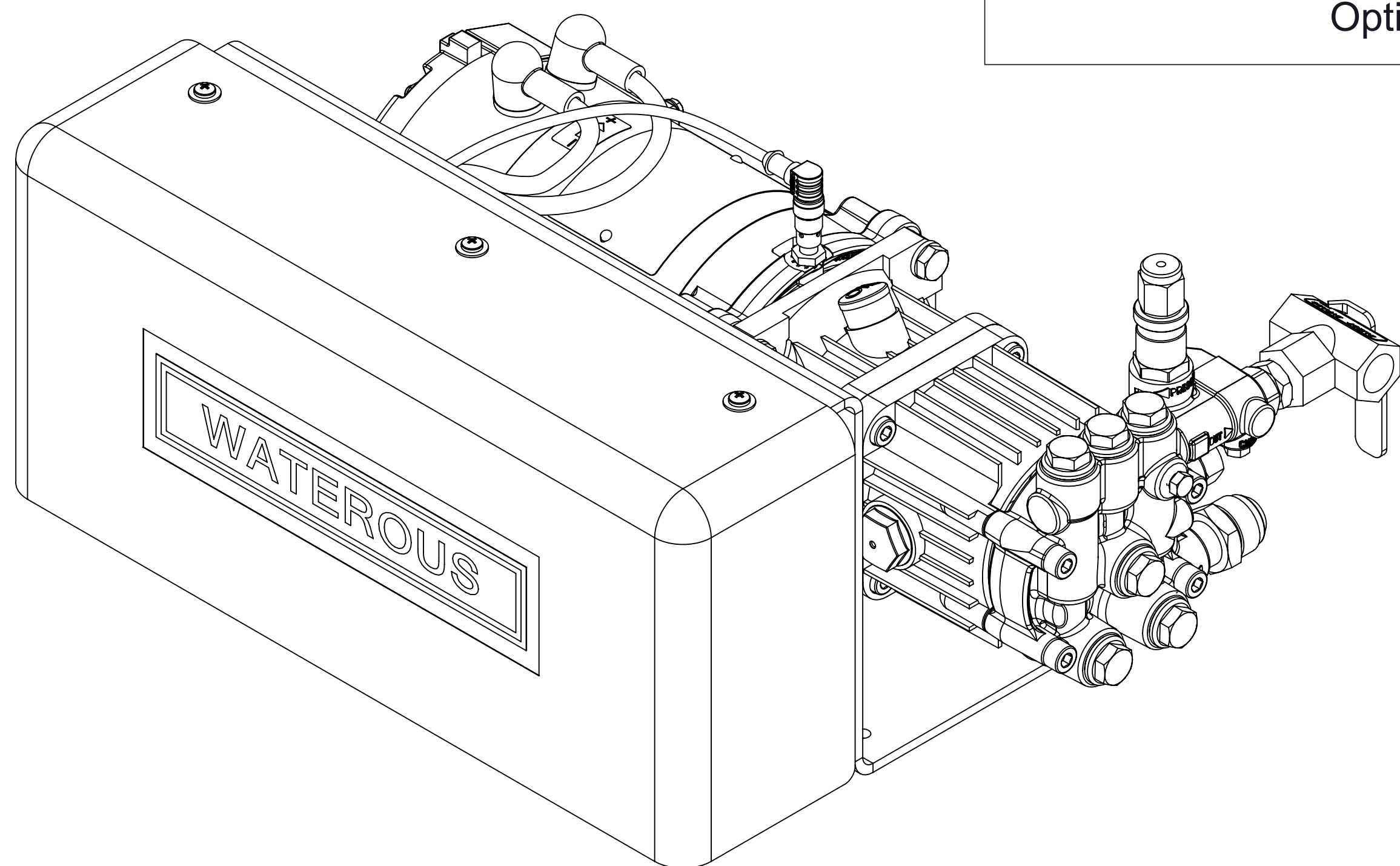
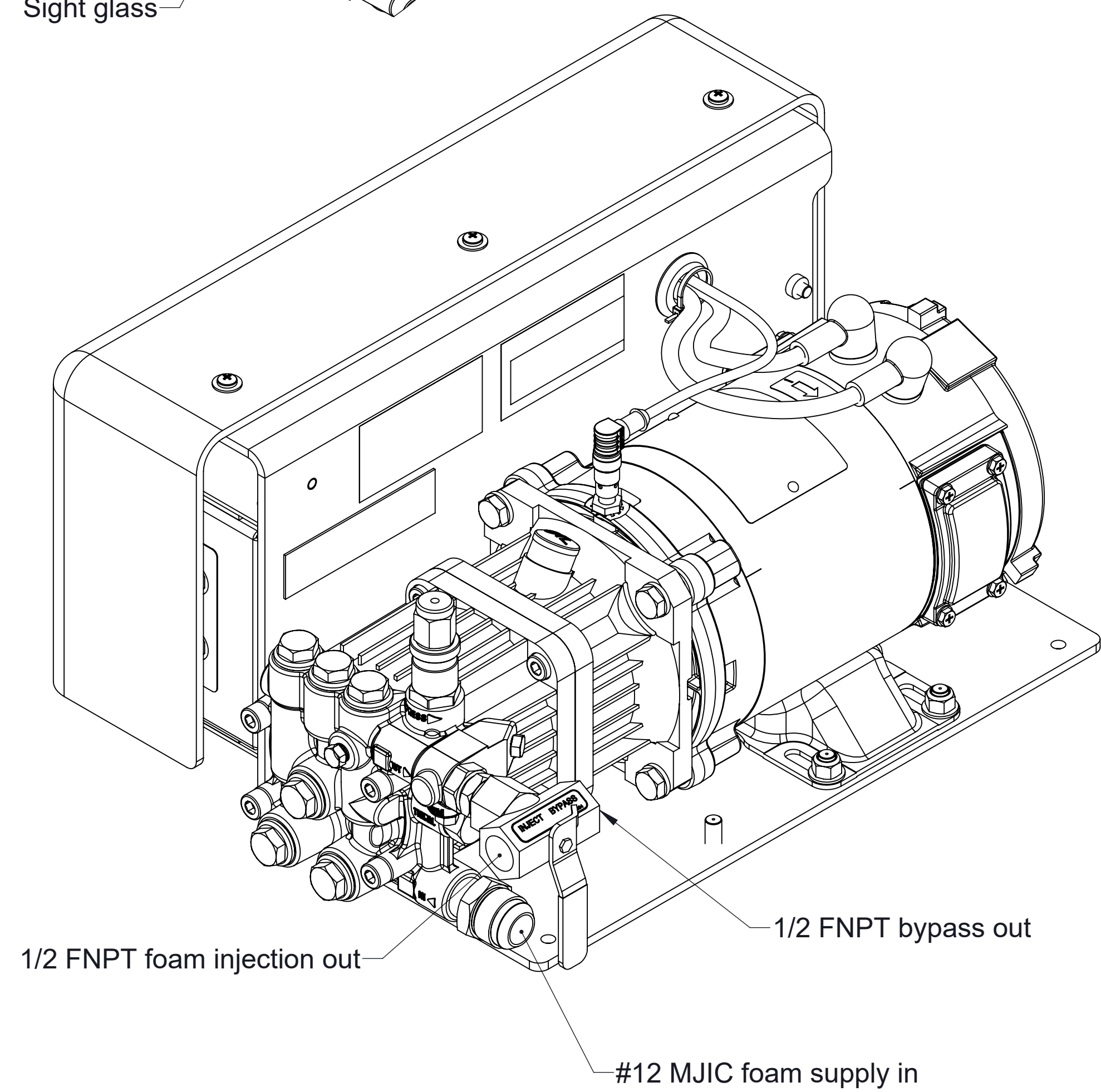
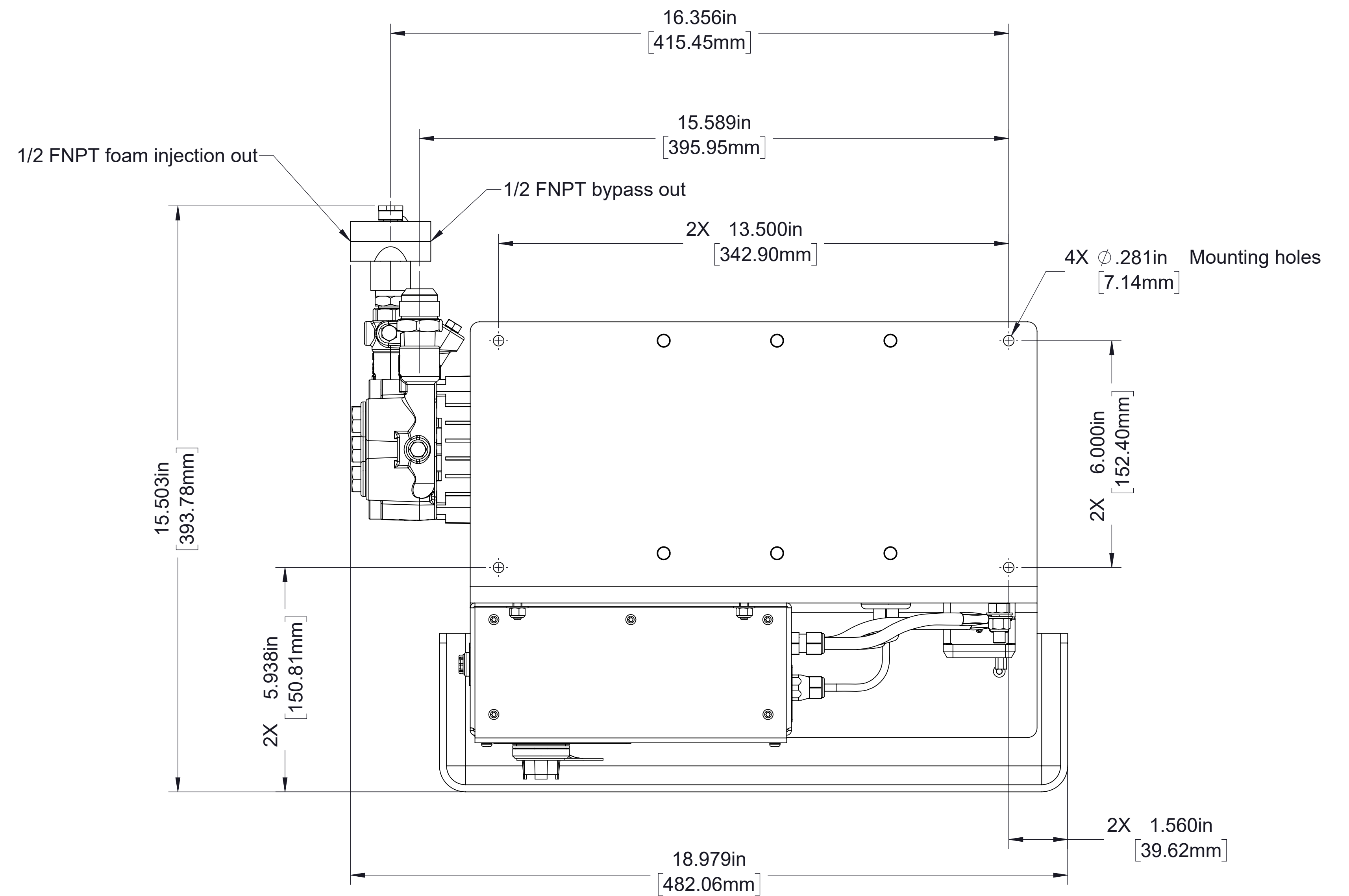
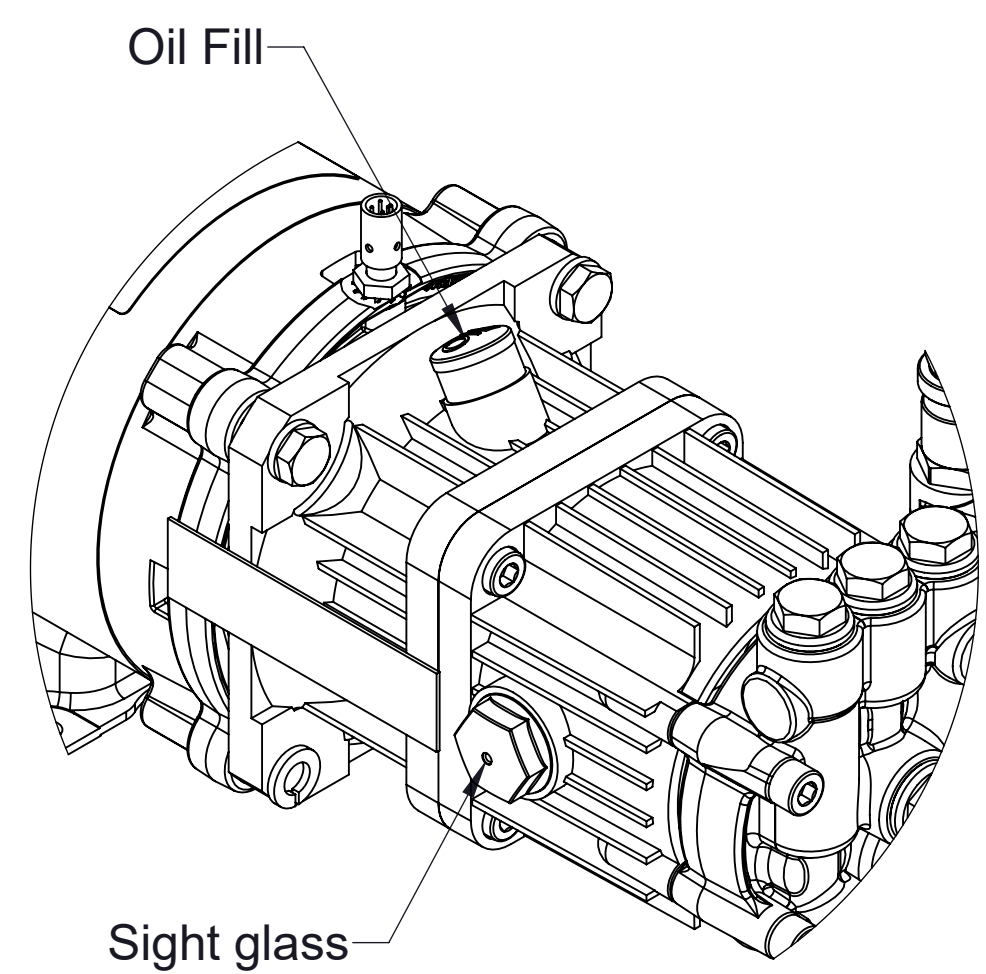
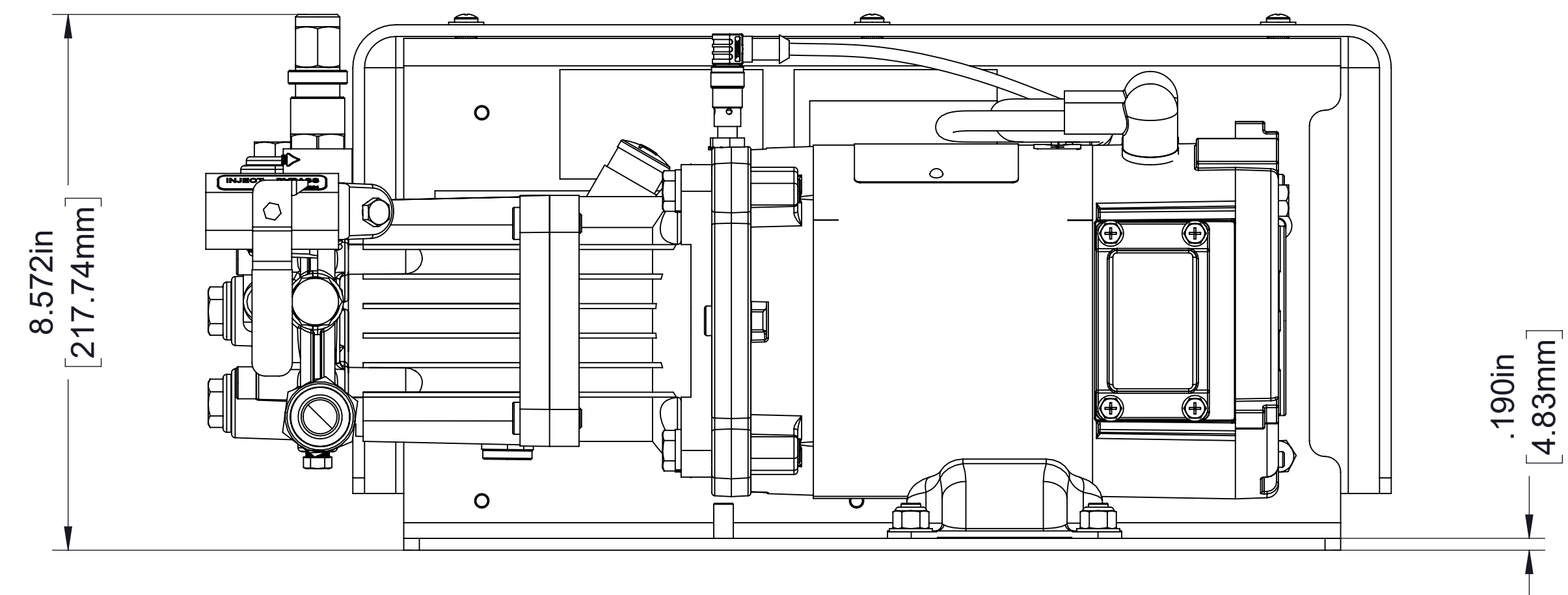
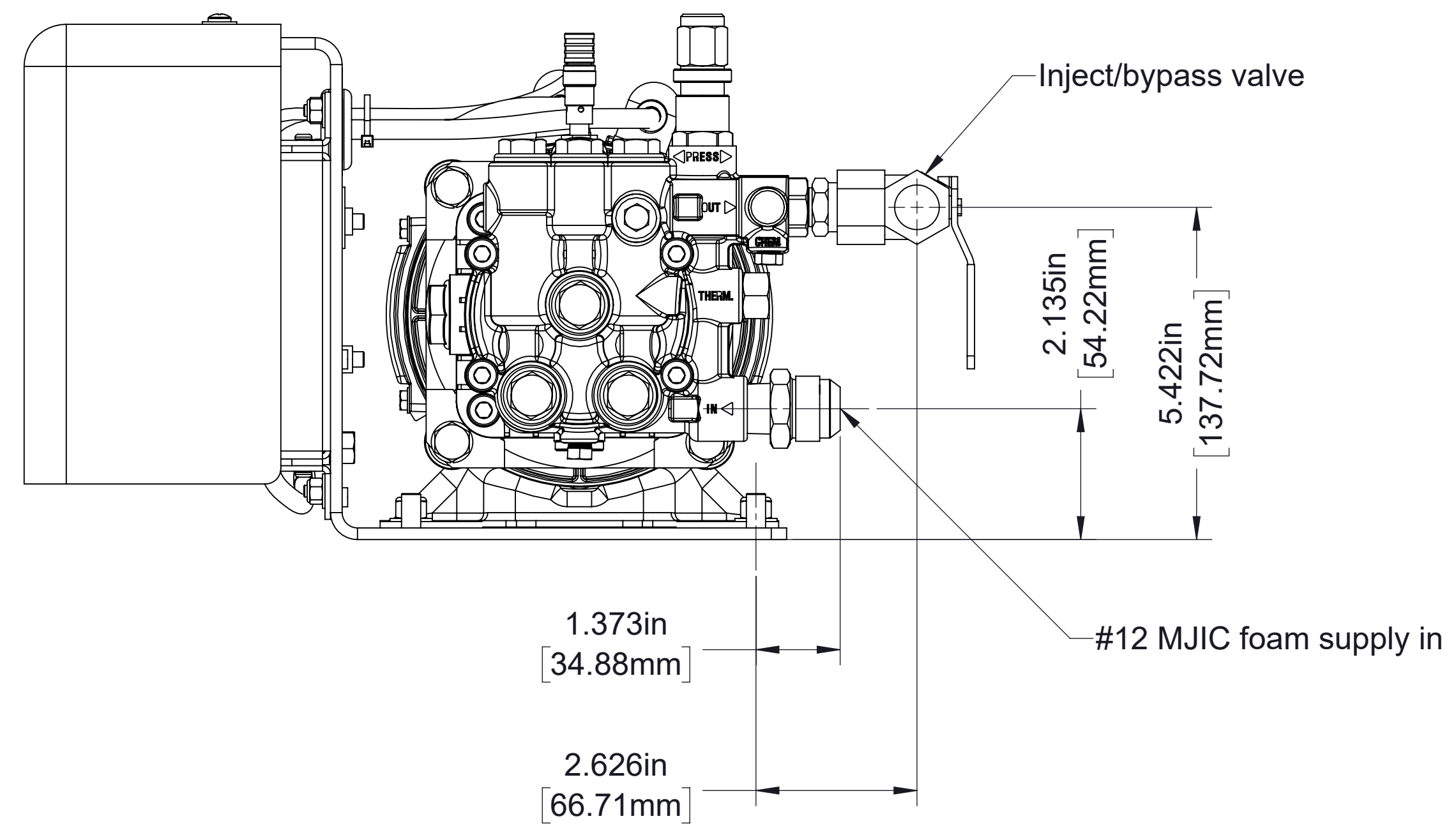

Model-Aquis 1.5

Note: Pump must be mounted on a horizontal surface.

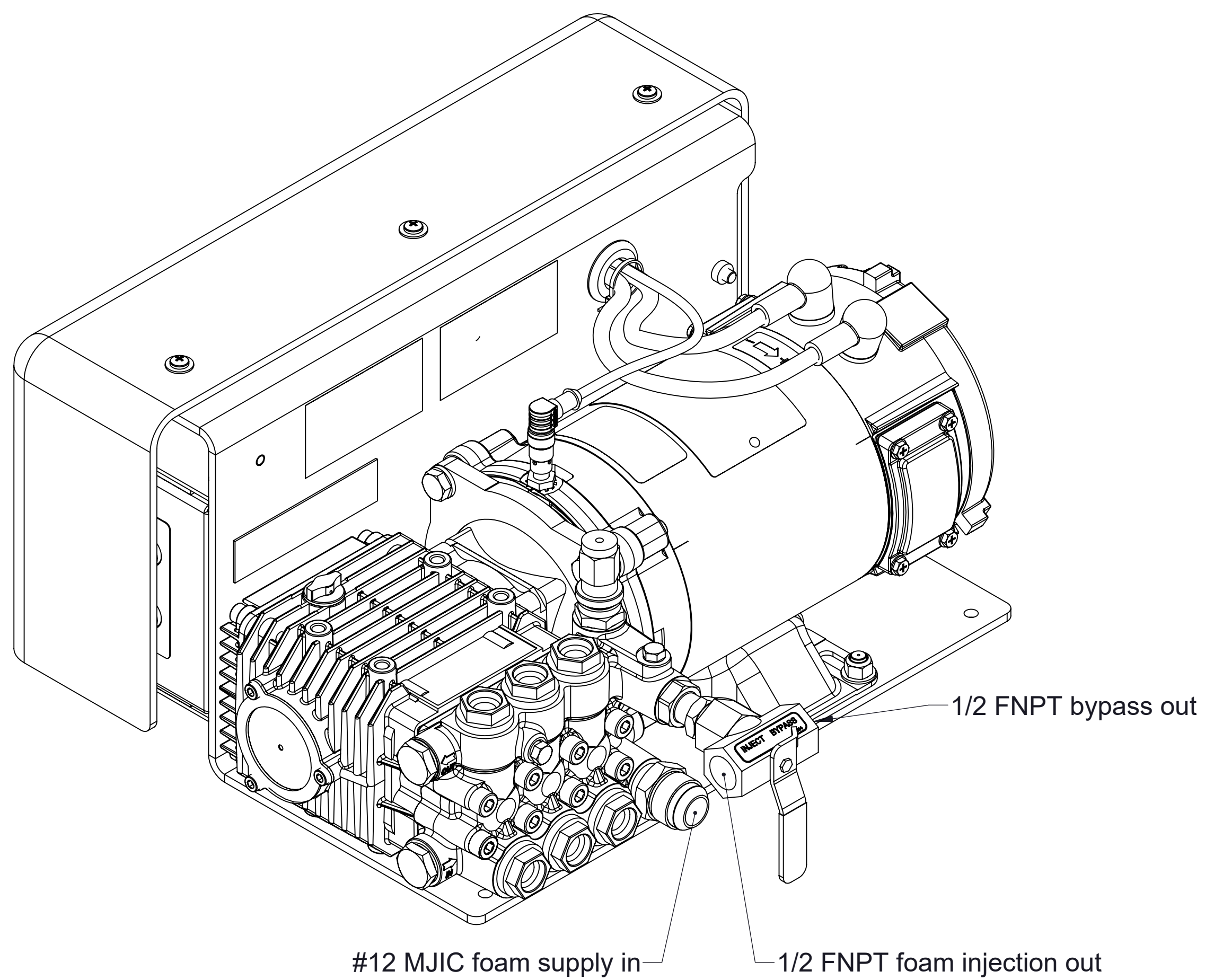
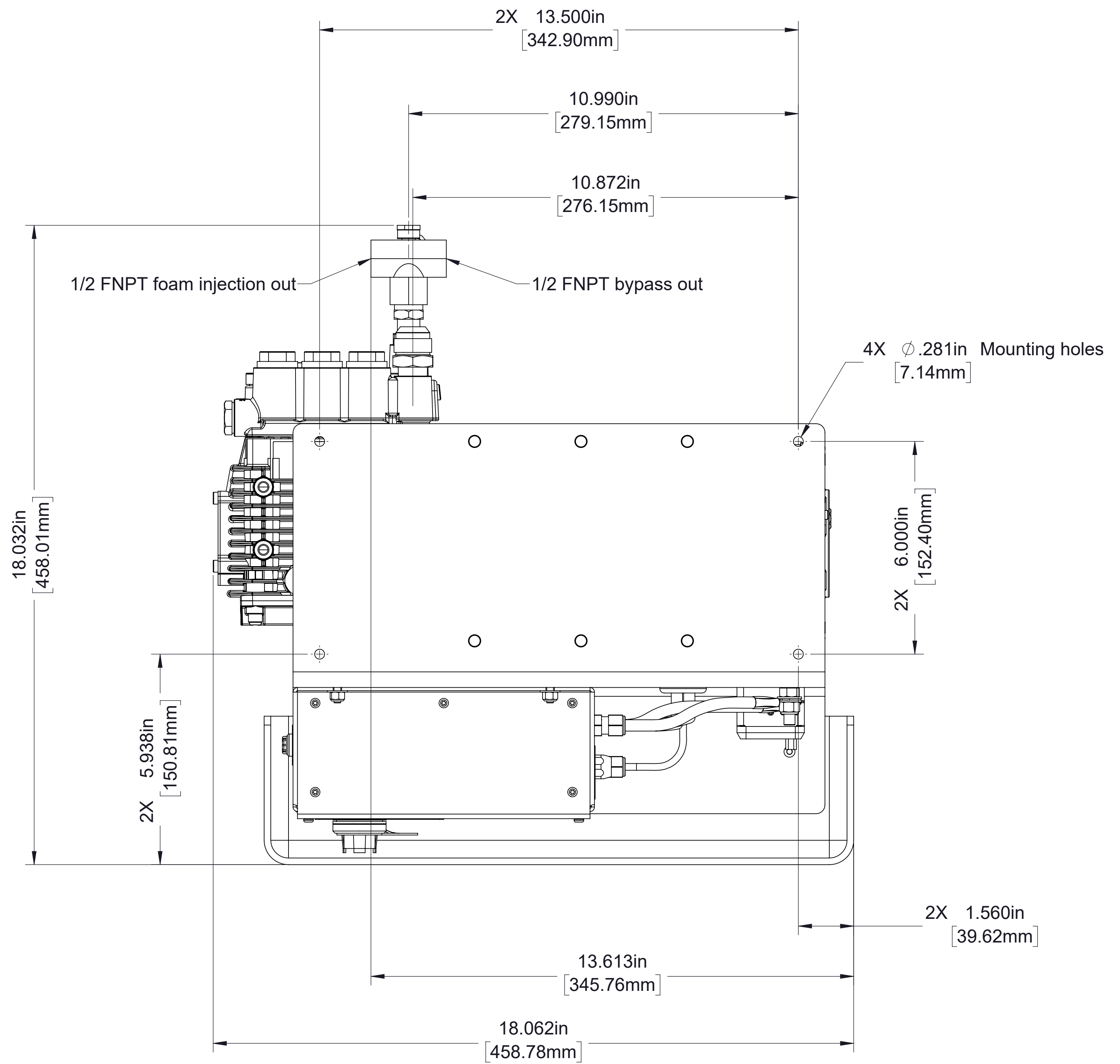
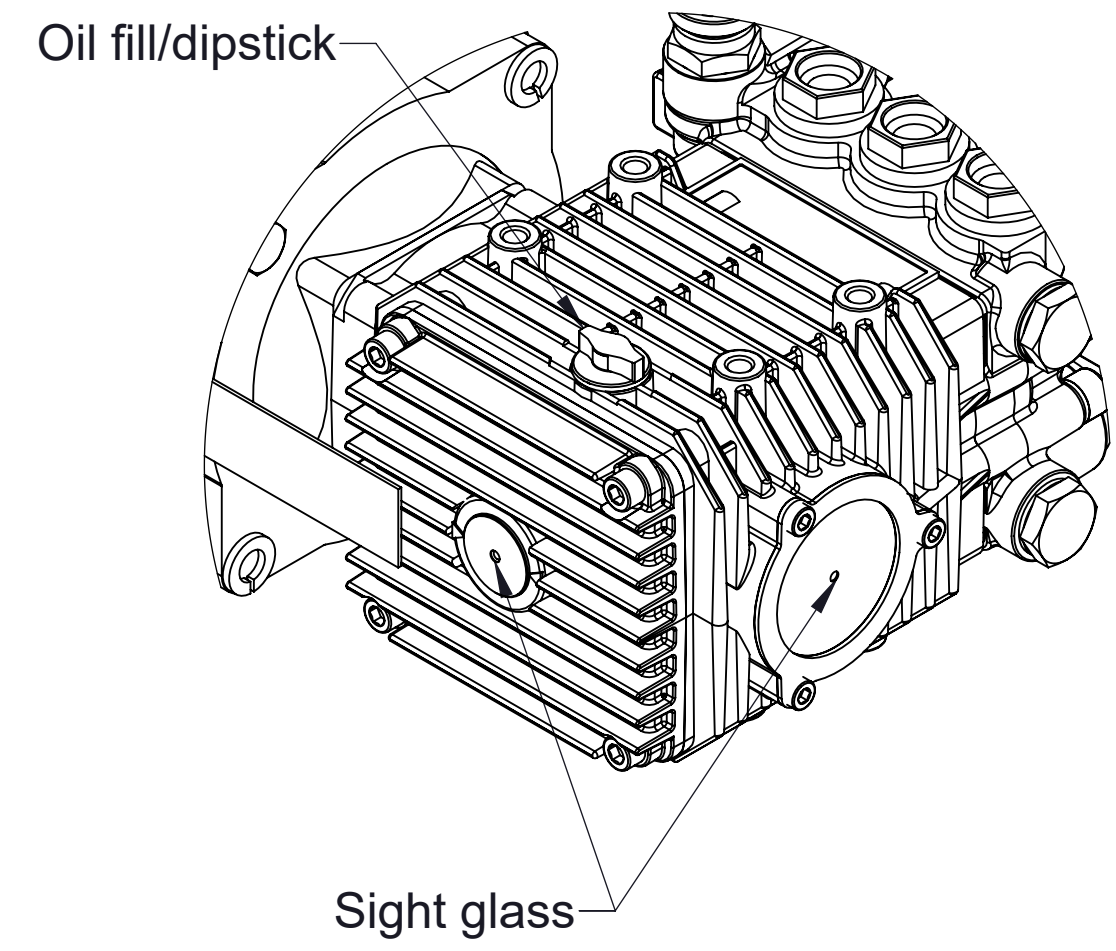
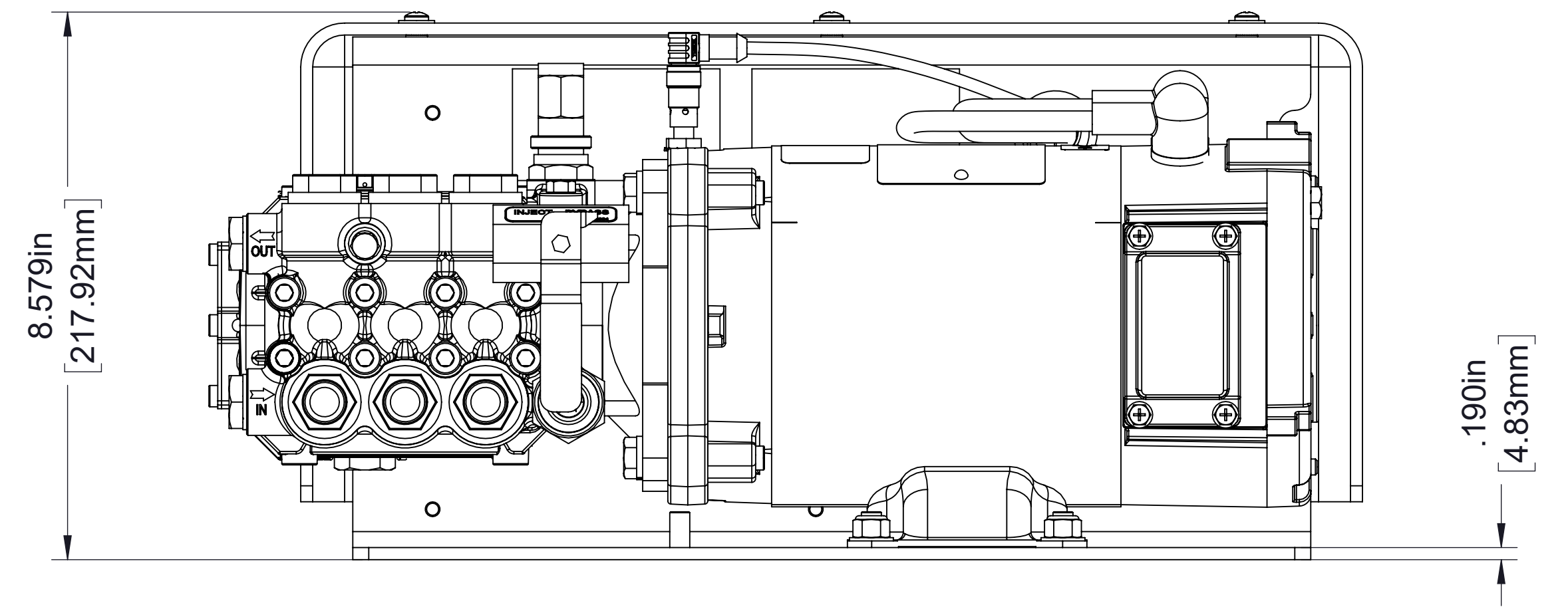
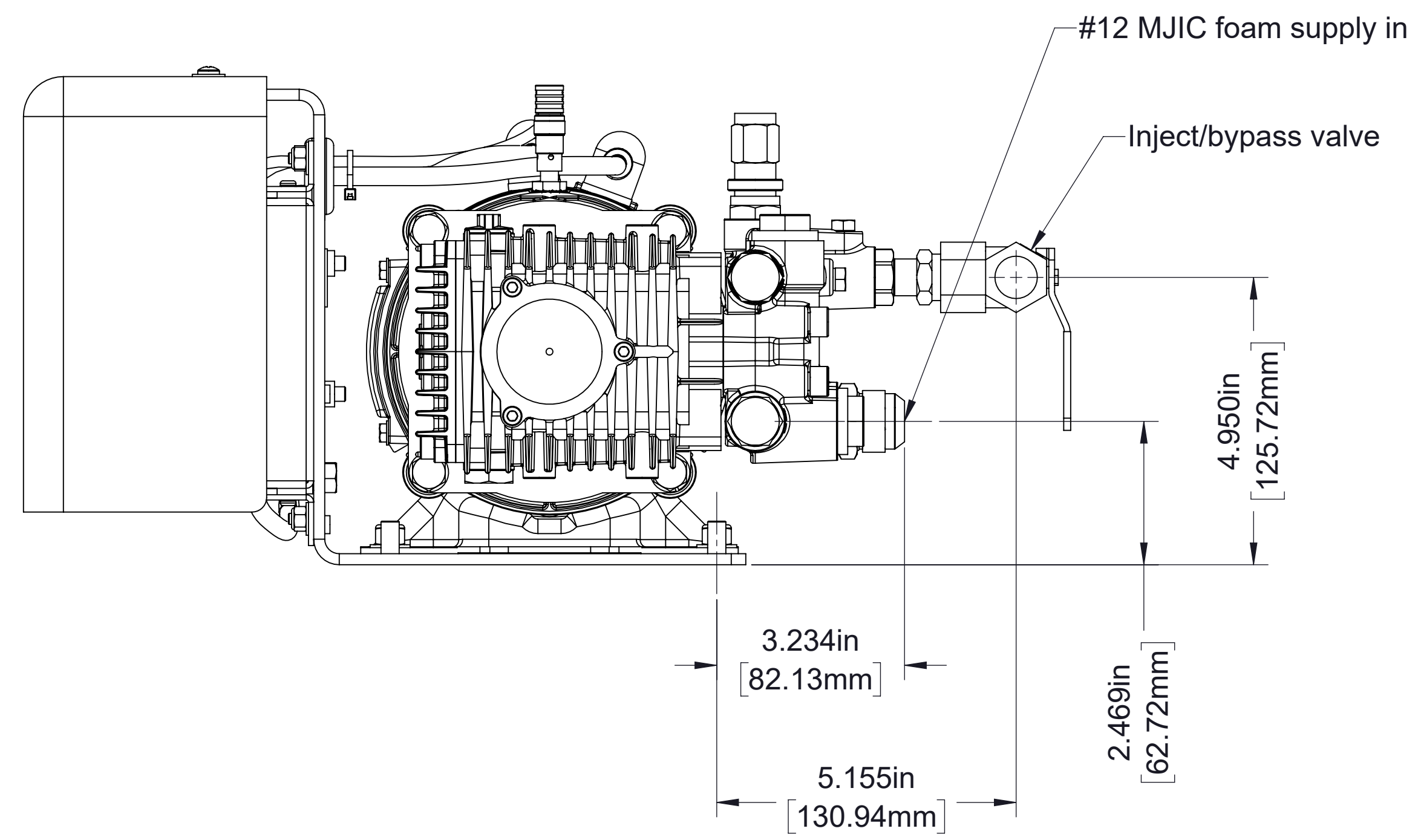

Model-Aquis 3.0

Note: Pump must be mounted on a horizontal surface.

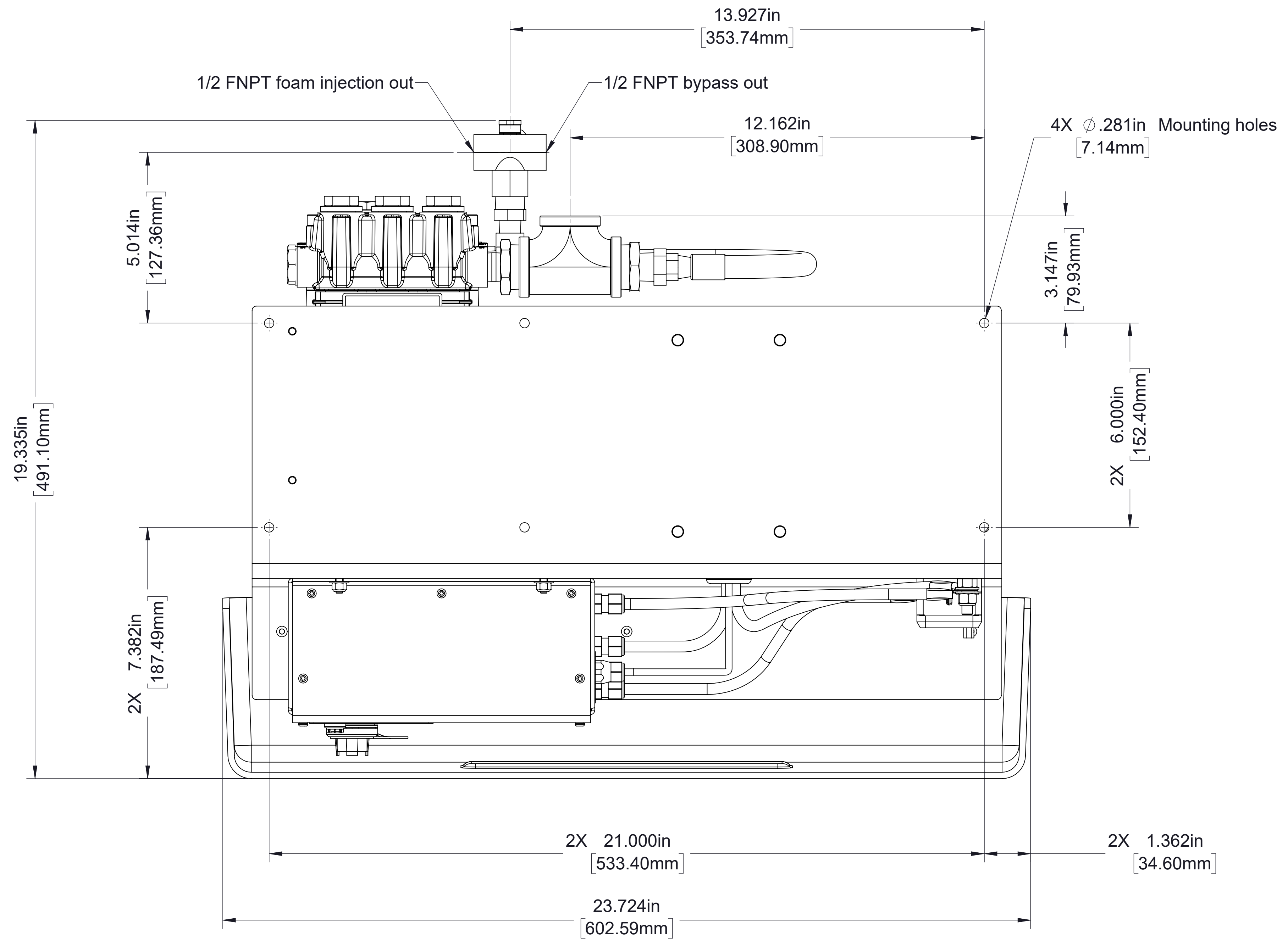
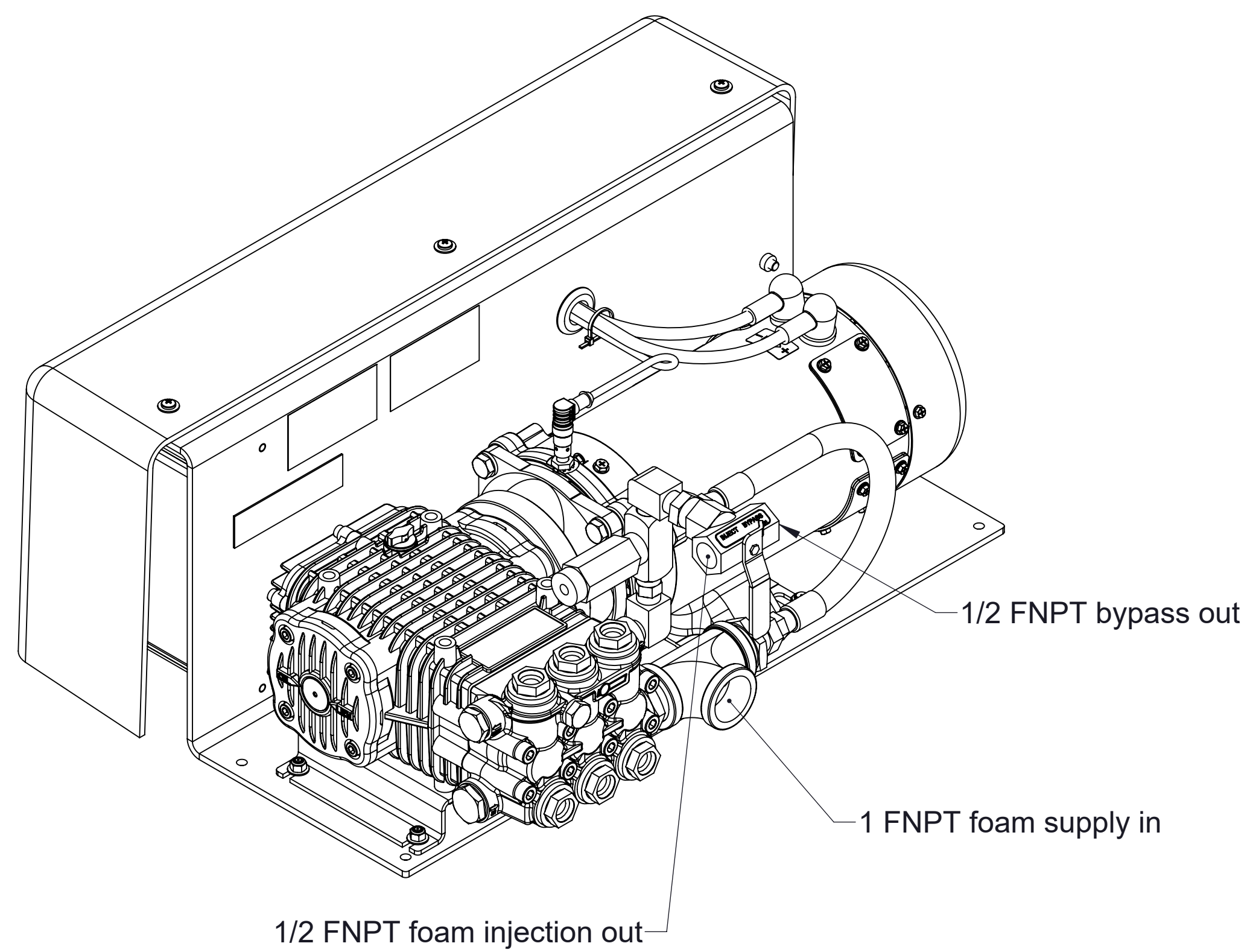
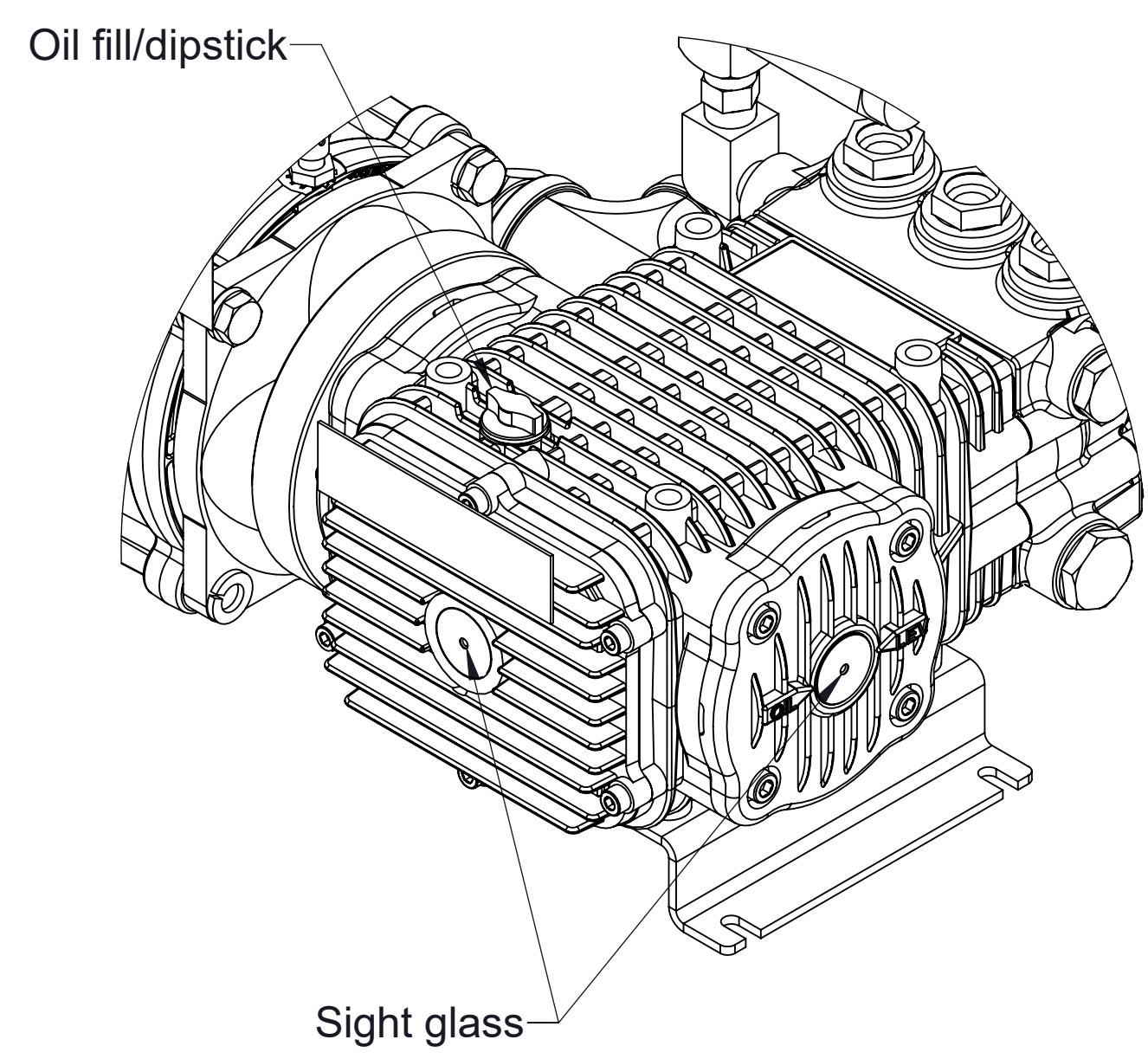
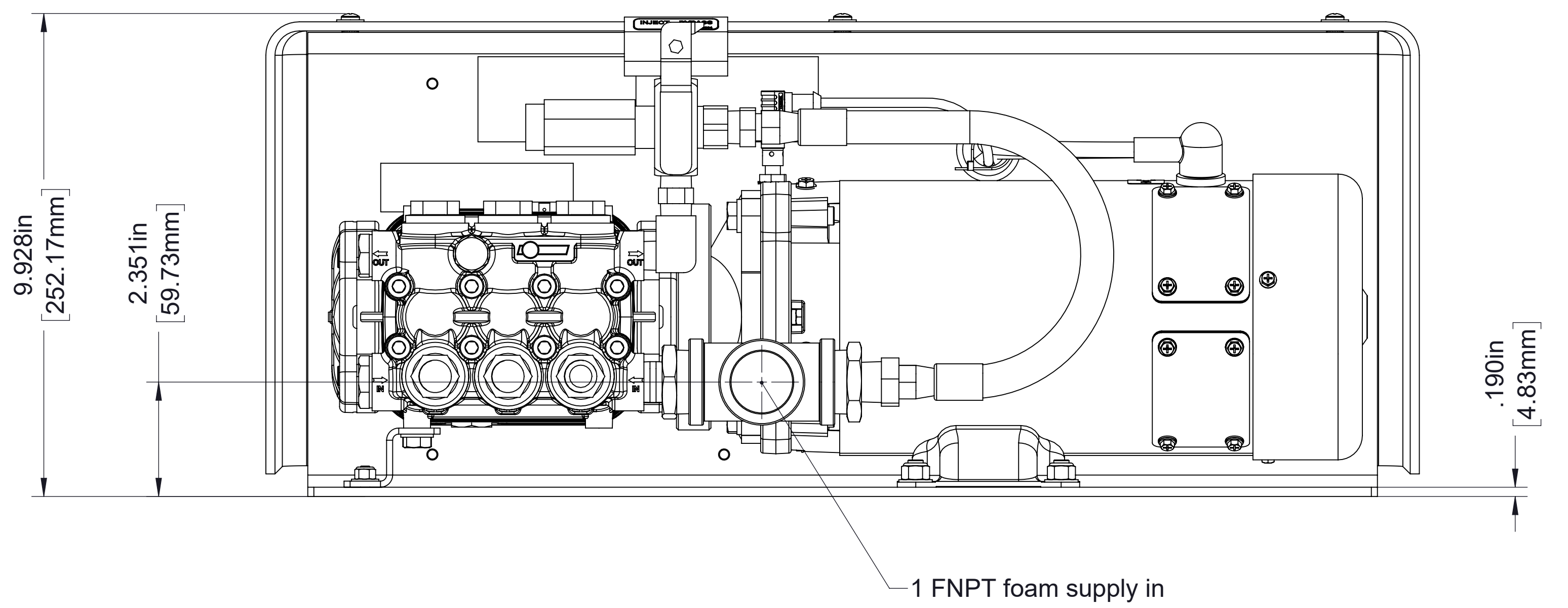
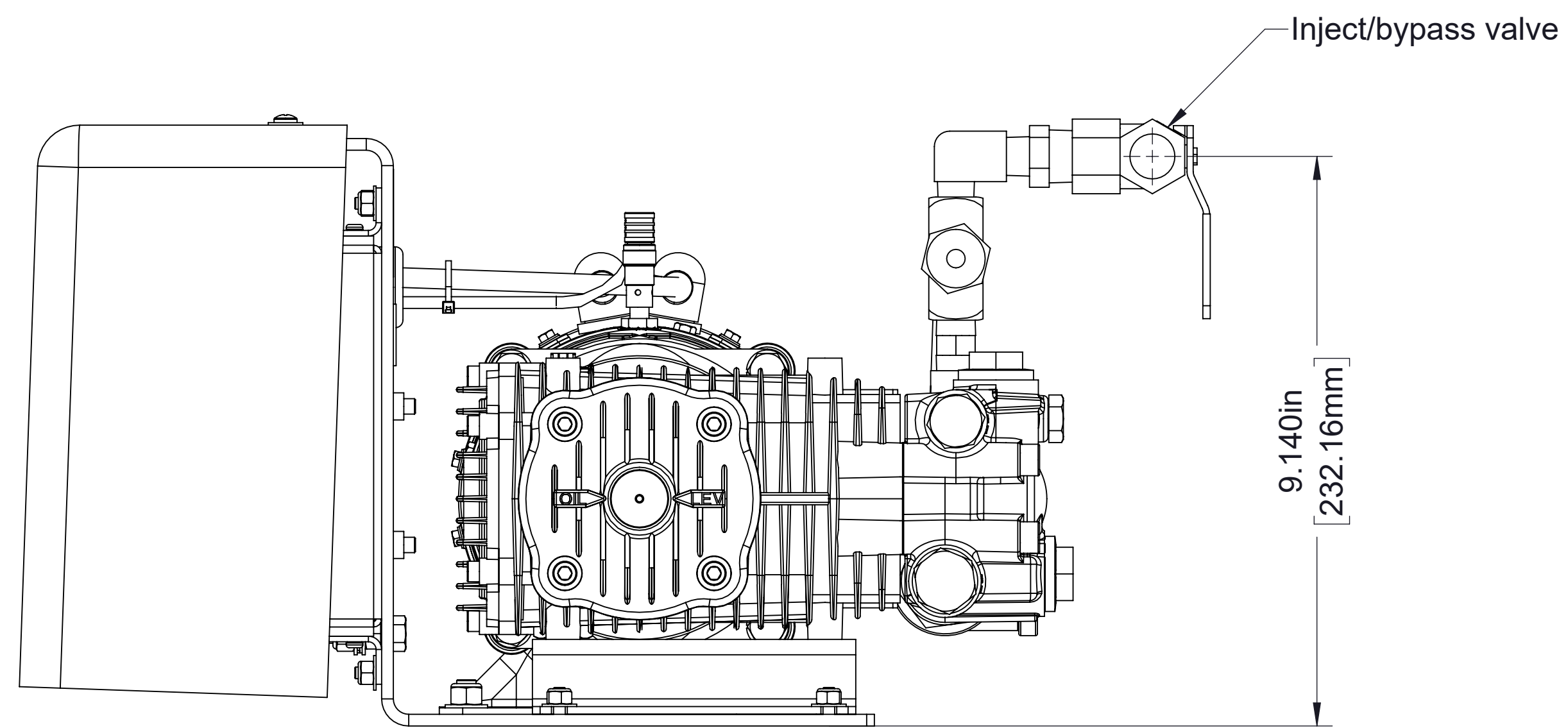

Model-Aquis 6.0

Note: Pump must be mounted on a horizontal surface.

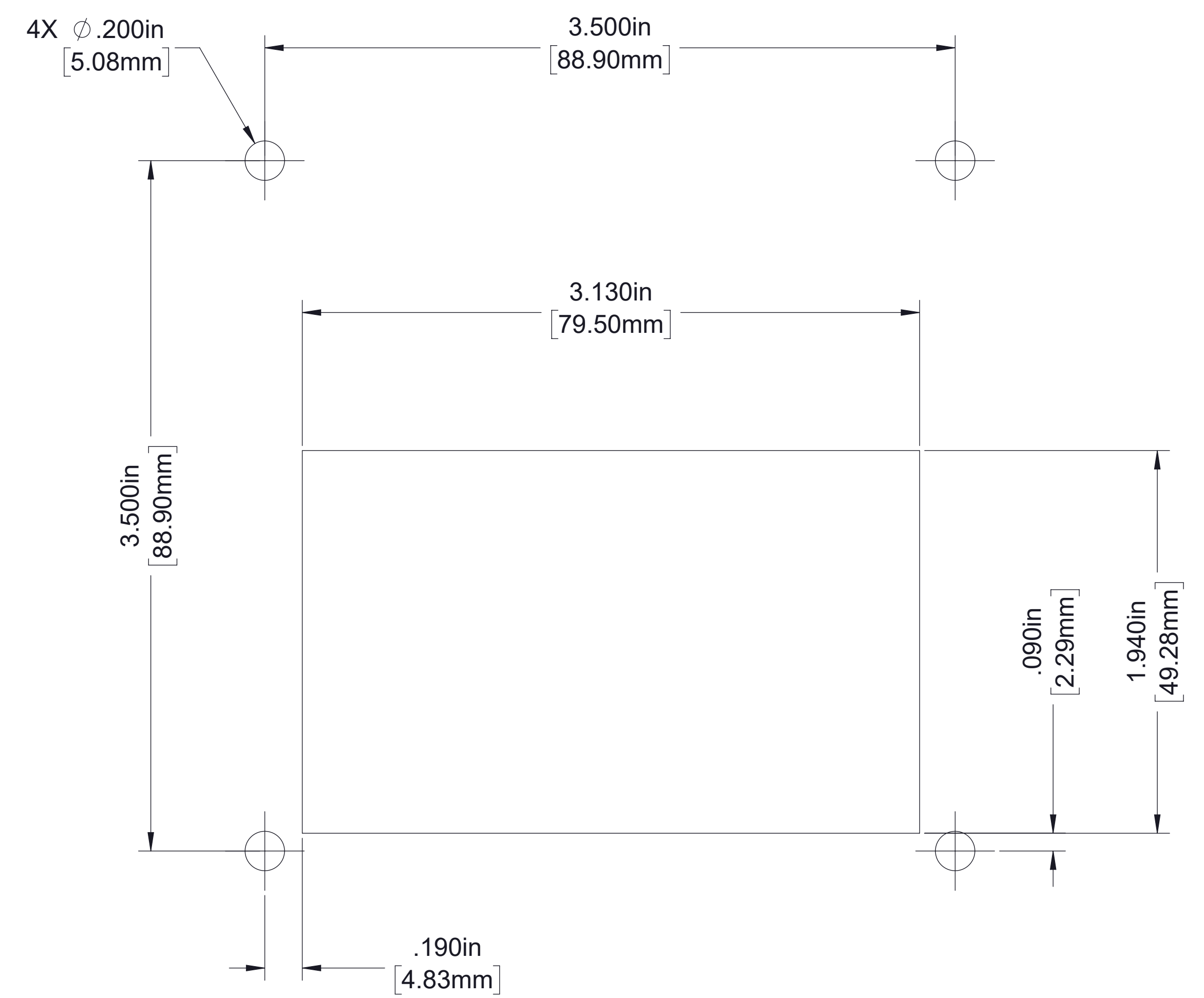
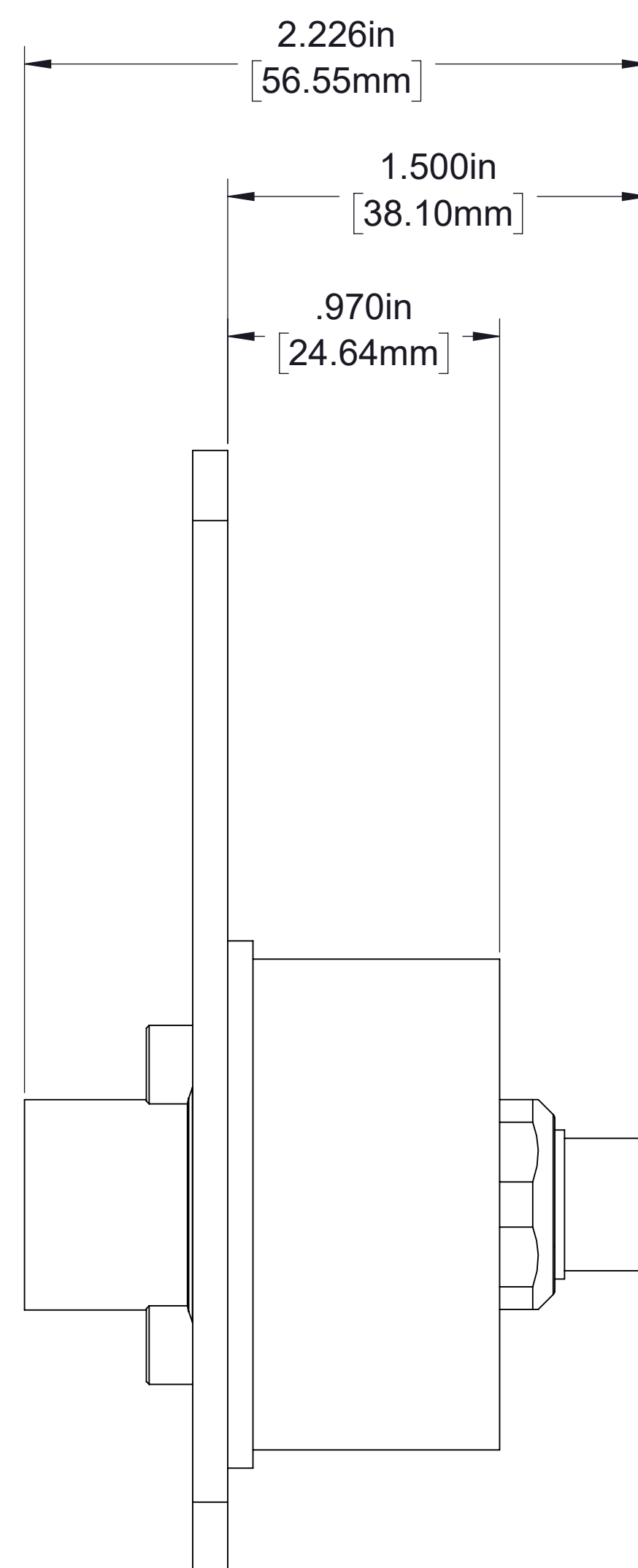
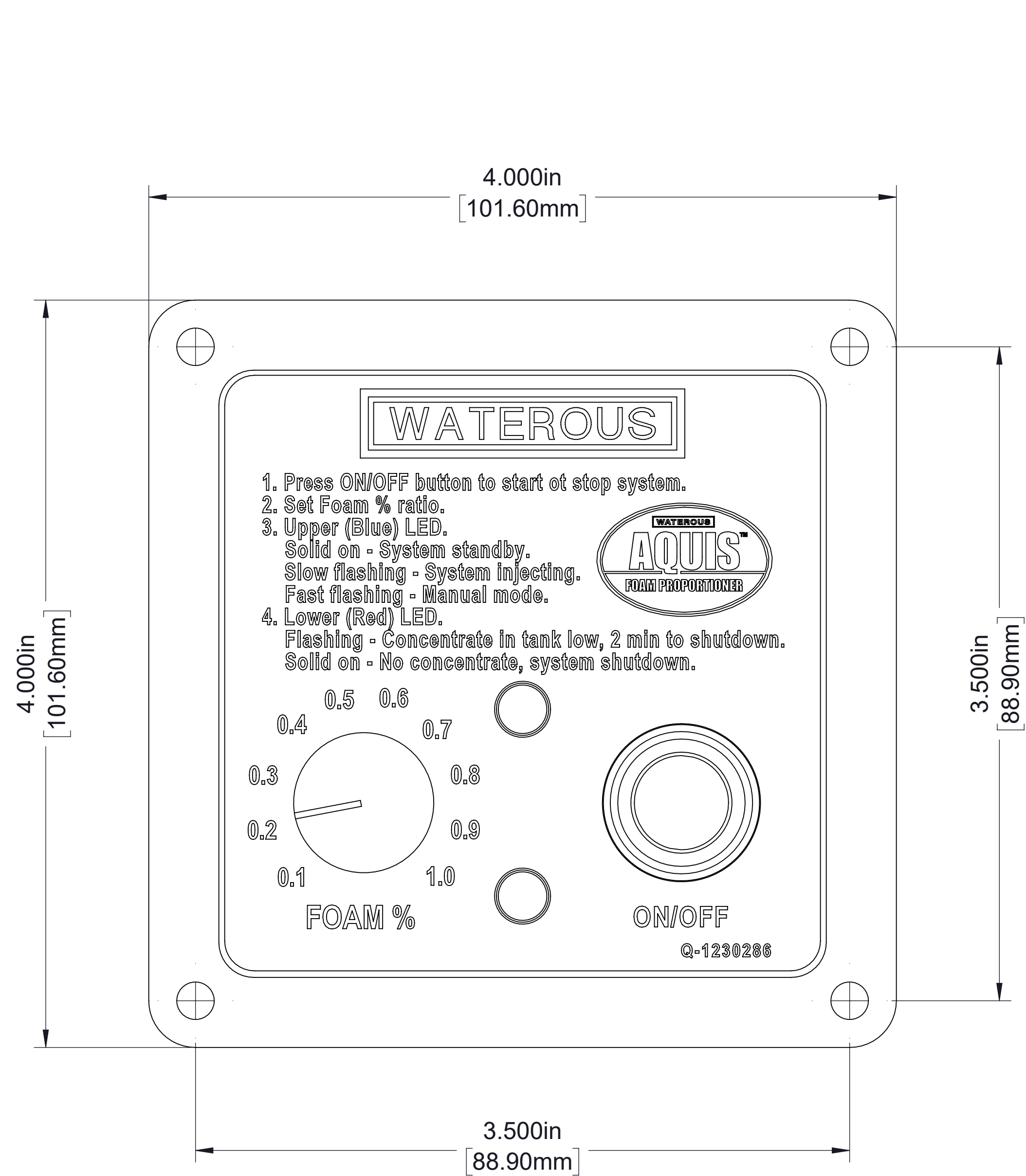

Panel Hole Cutout

Manual OIT

Available cable extensions:
 9.8 ft / 3 meters-part number Q-4310006
 19.6 ft / 6 meters-part number Q-4310007

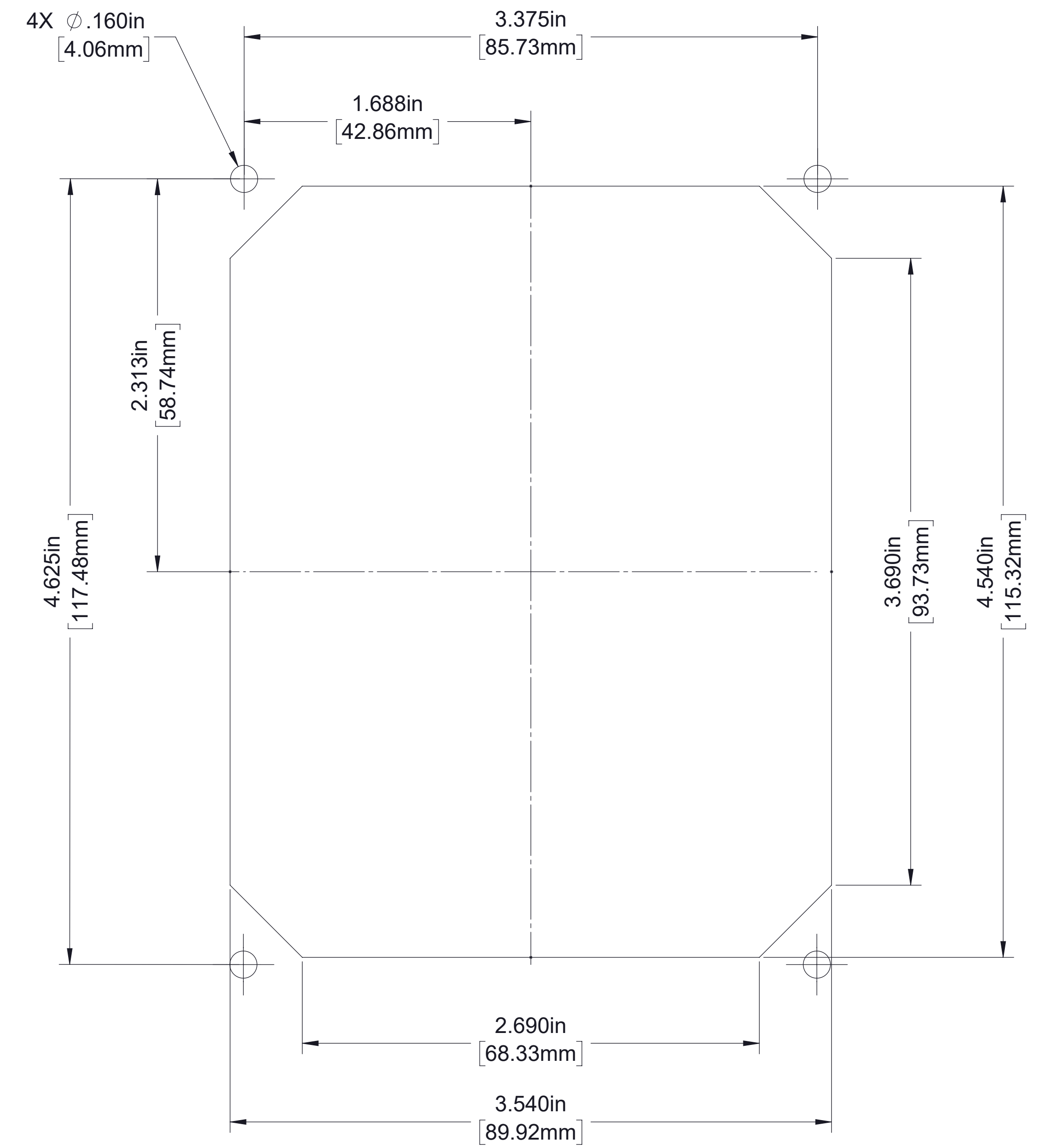
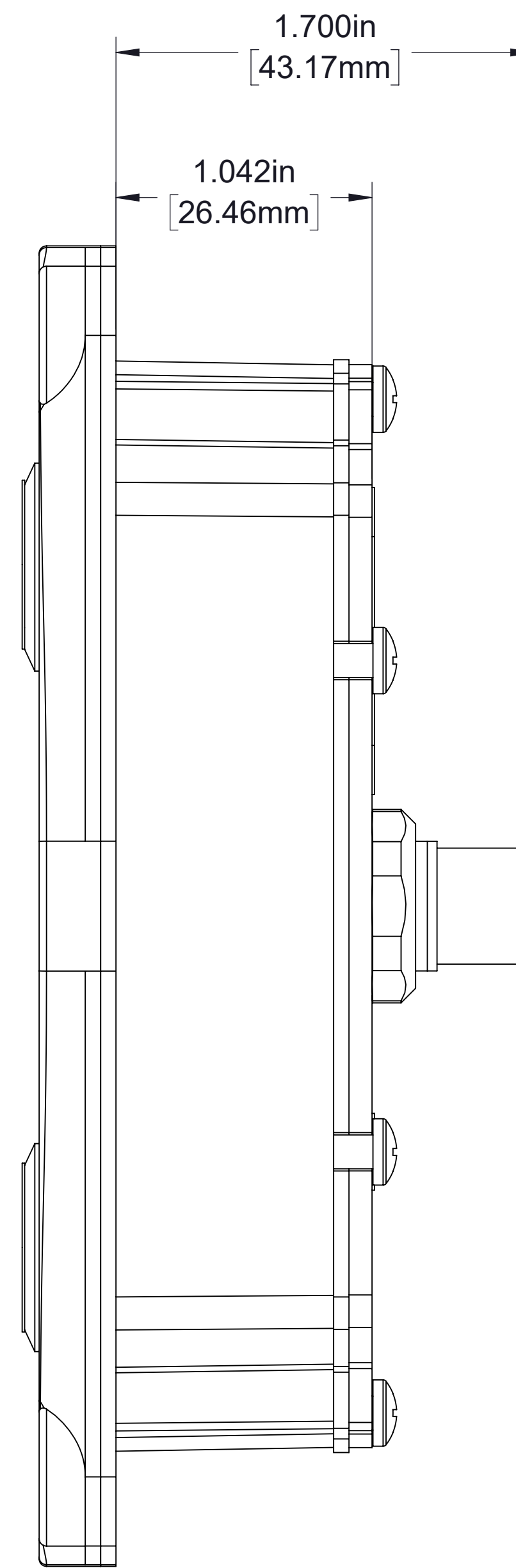
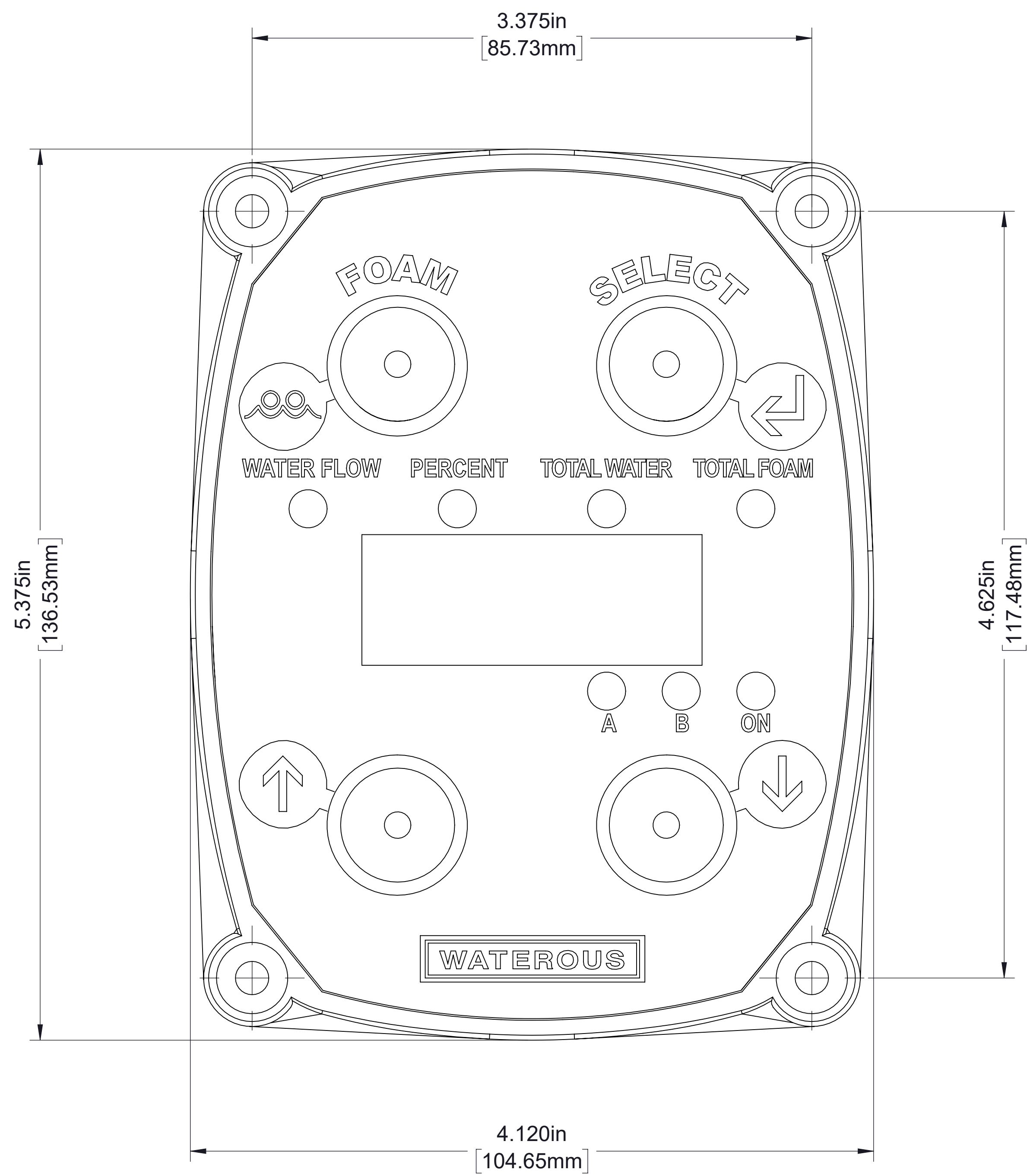

Panel Hole Cutout

(Use the self-tapping screws included to secure the OIT to the panel)

Digital OIT

(See next page for Instruction Plate)

Available cable extensions:
 9.8 ft / 3 meters-part number Q-4310006
 19.6 ft / 6 meters-part number Q-4310007

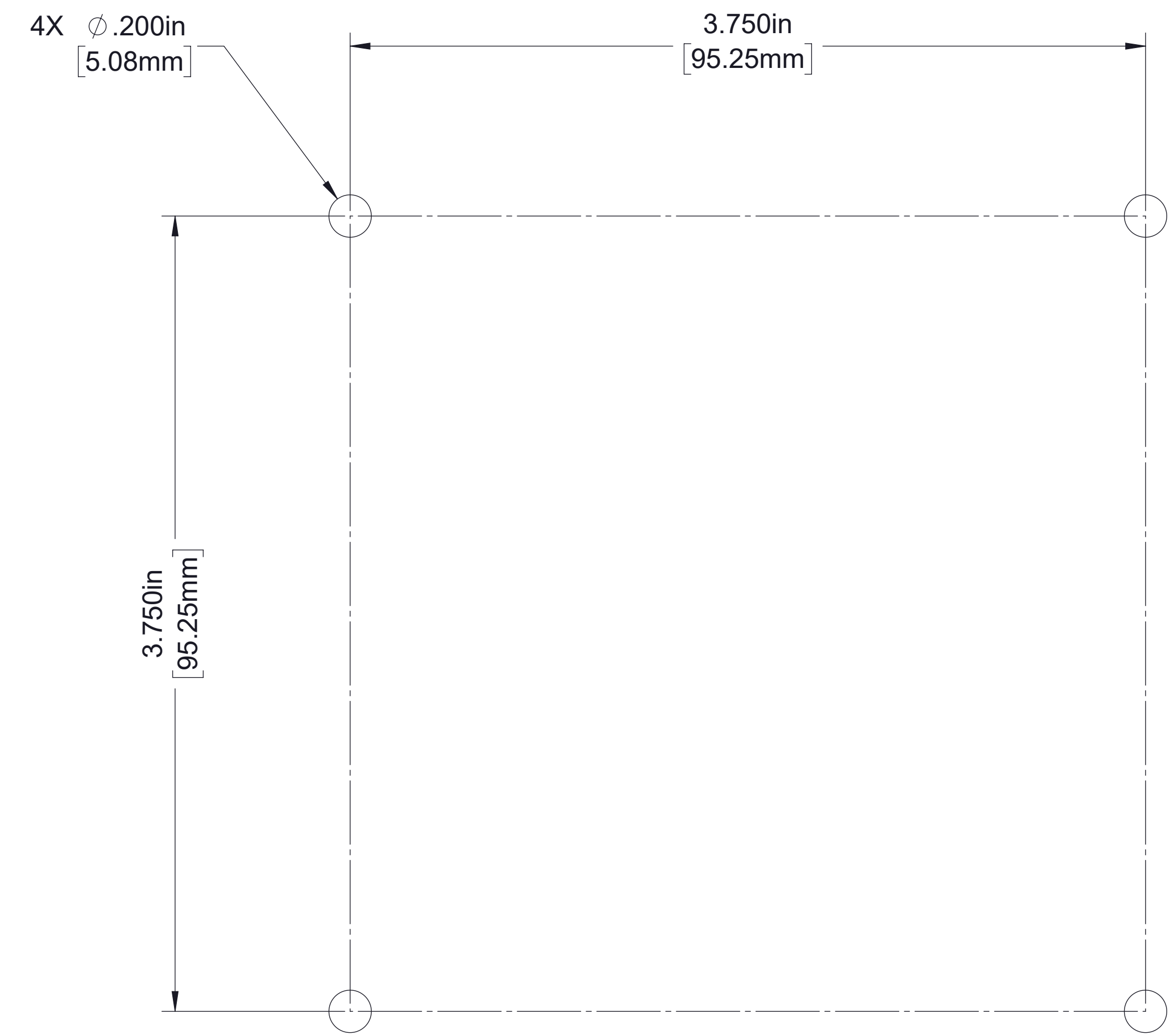
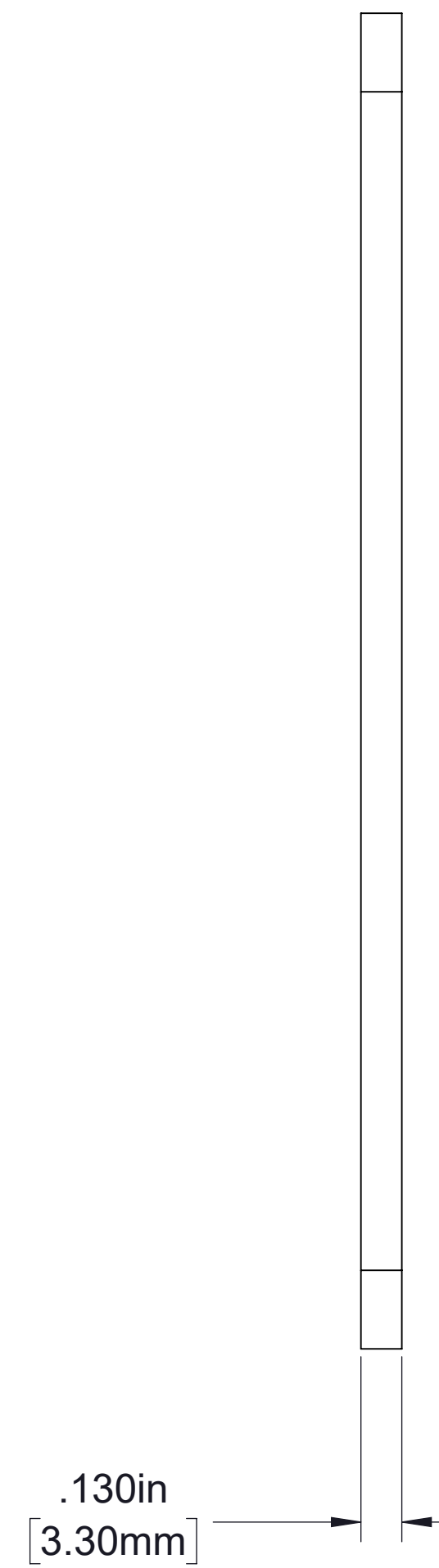
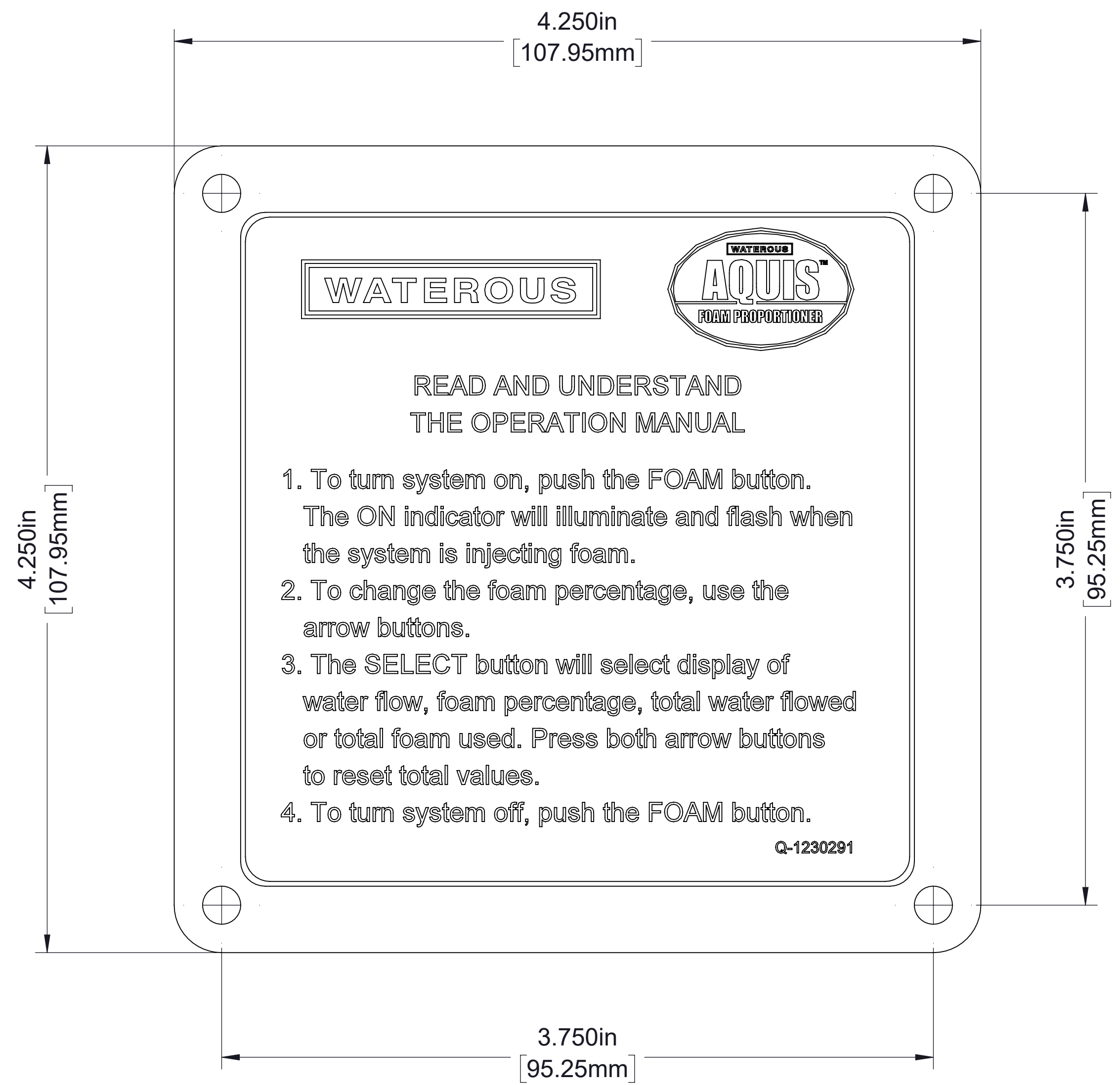

Panel Hole Layout

Instruction Plate for Digital OIT

Part number:
Q-0315322 (English)
63751 (Chinese)

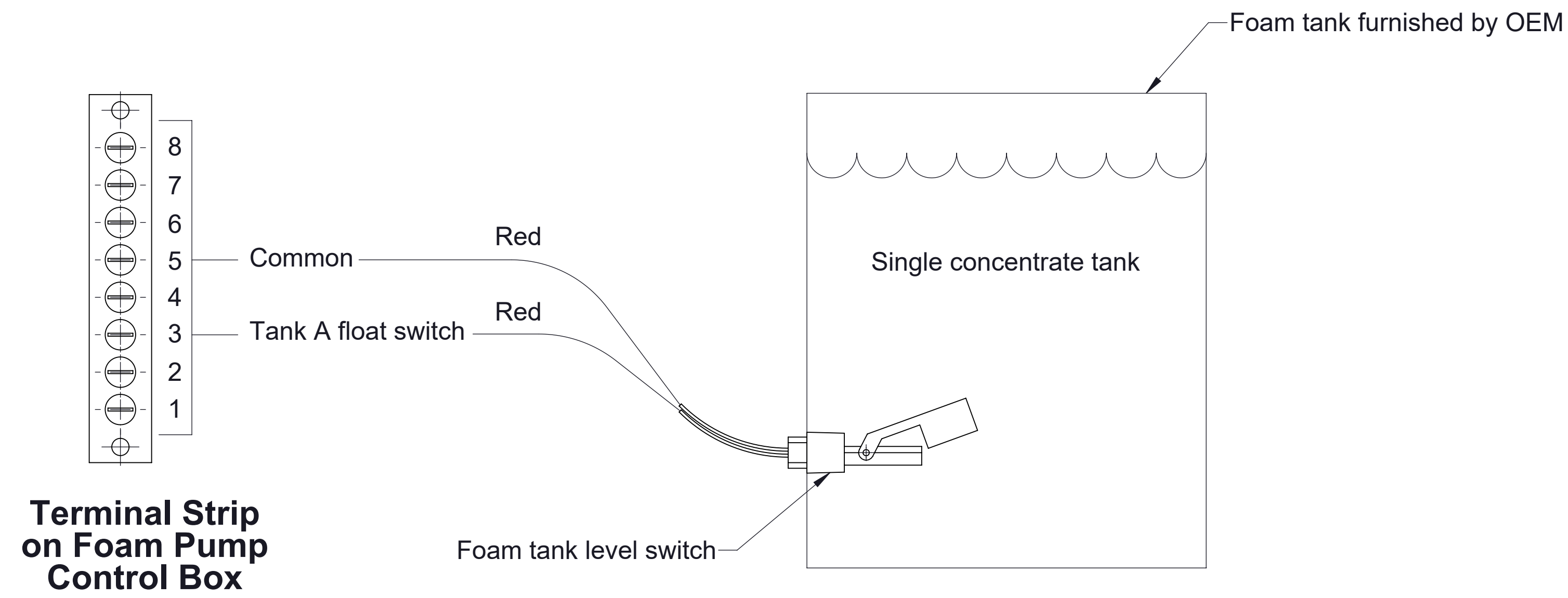

Wire Connections to Foam Pump

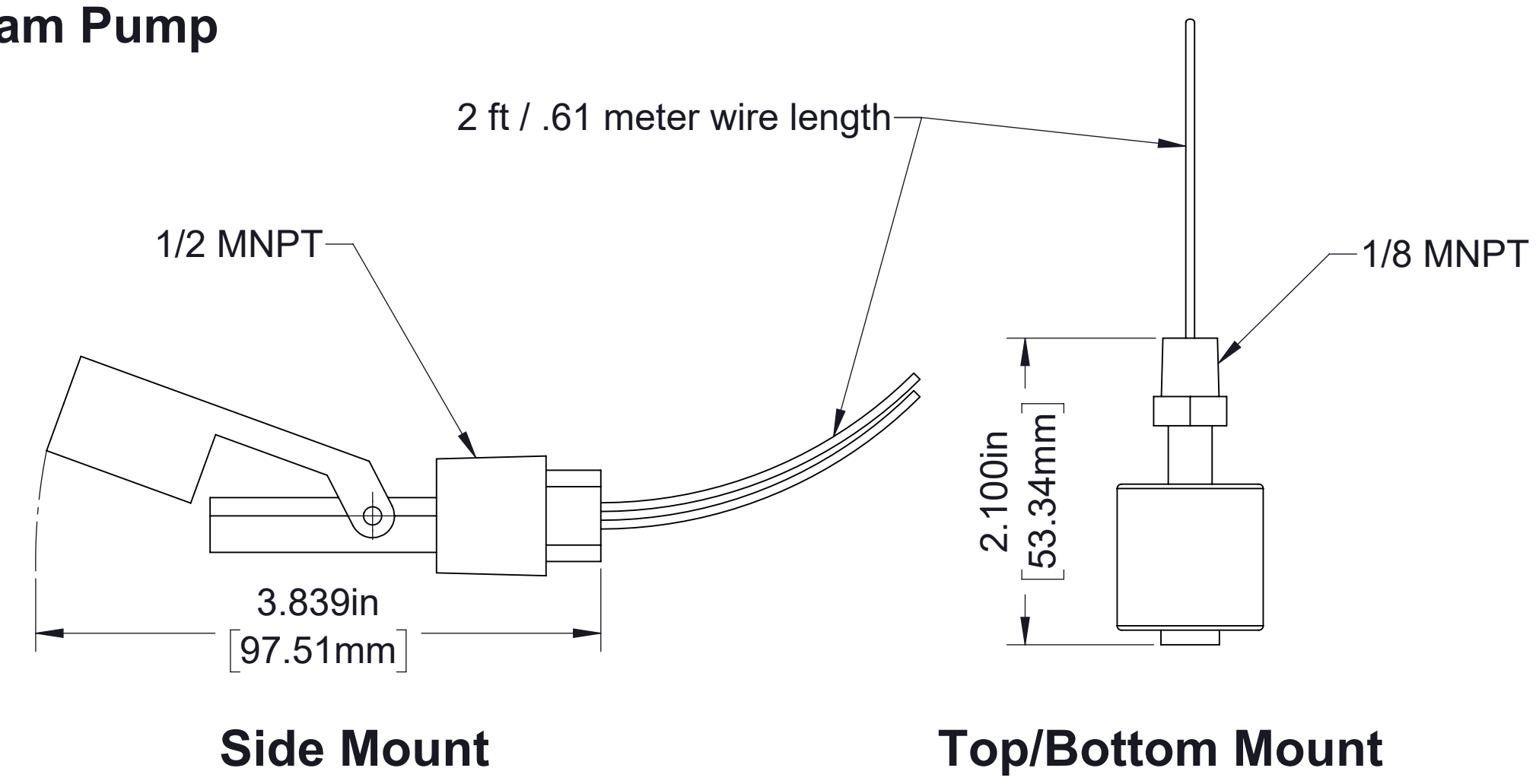

Optional Foam Level Tank Switch

Order part number:
 Q-4190000 (side mount)
 Q-4190001 (top/bottom mount)

Available wire extension-13.1 ft/ 4 meters
 Order part number:
 Q-4310014

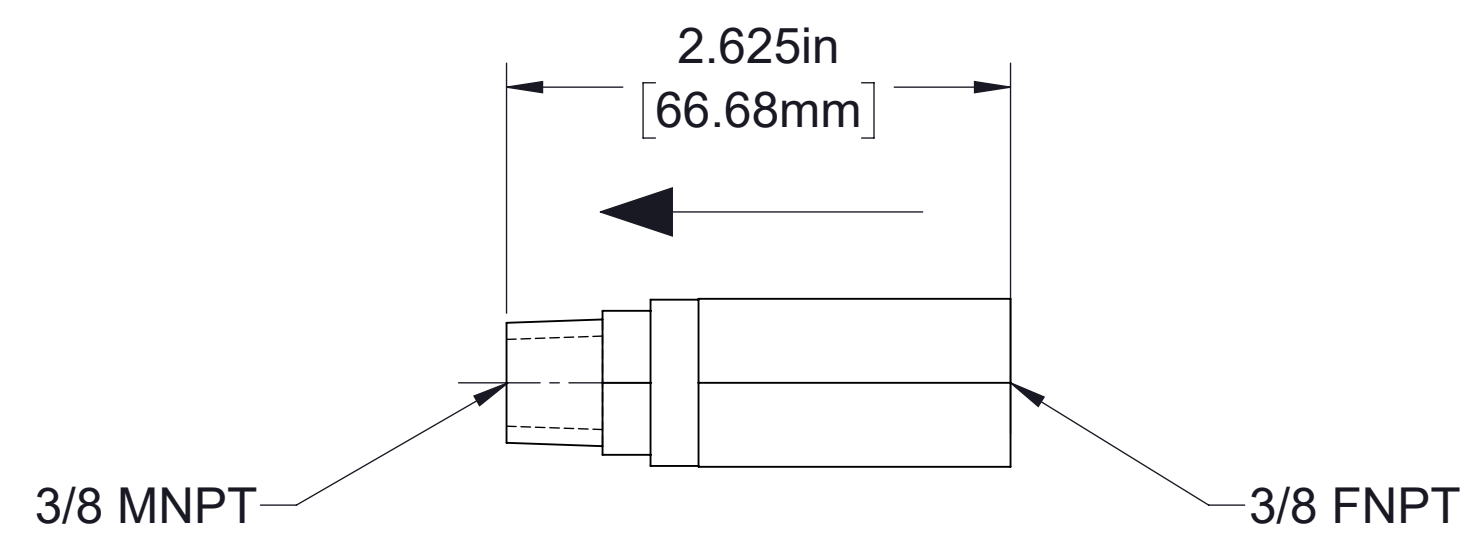

Foam Injection Check Valve

(All models)

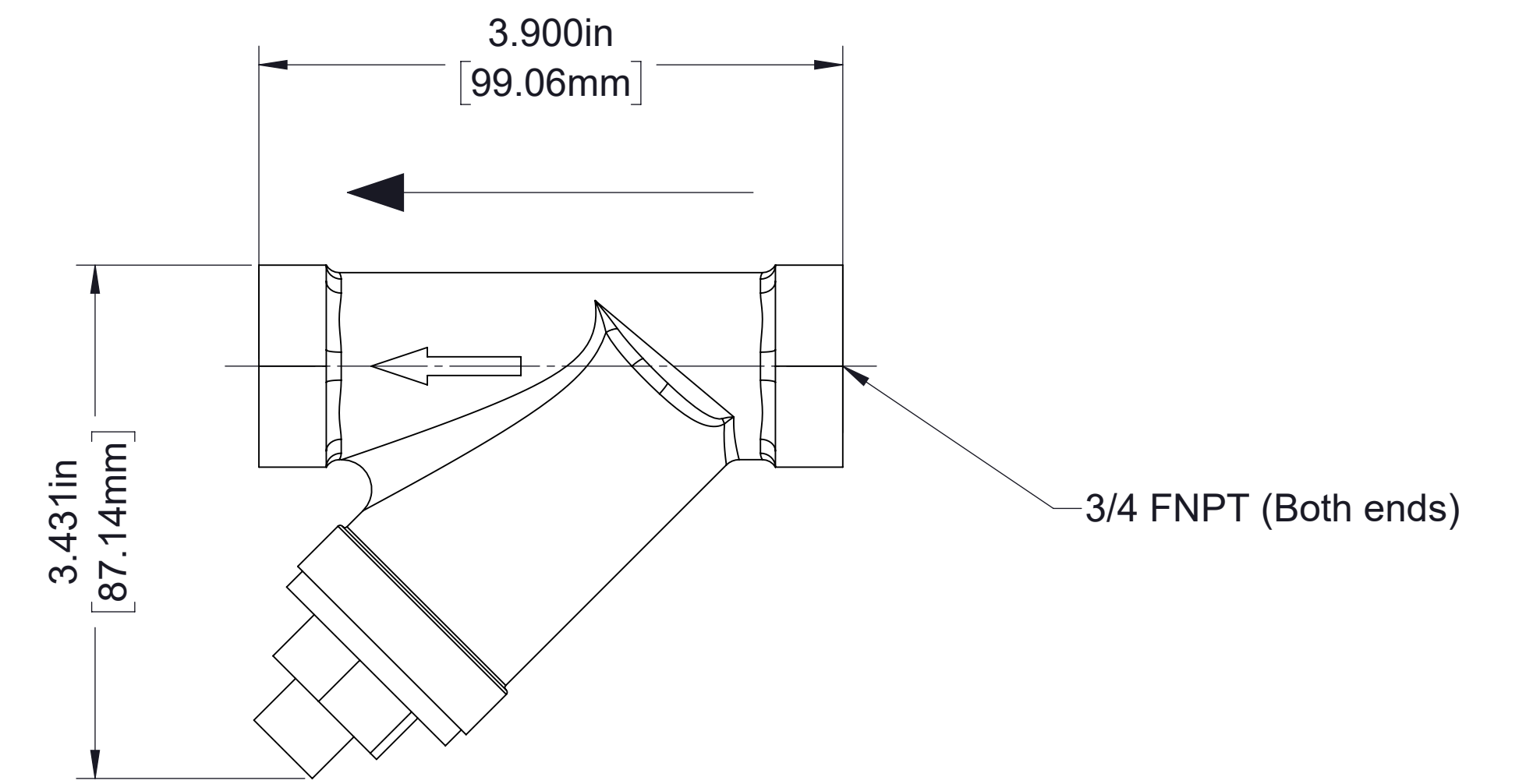

Aquis 1.5 and 3.0

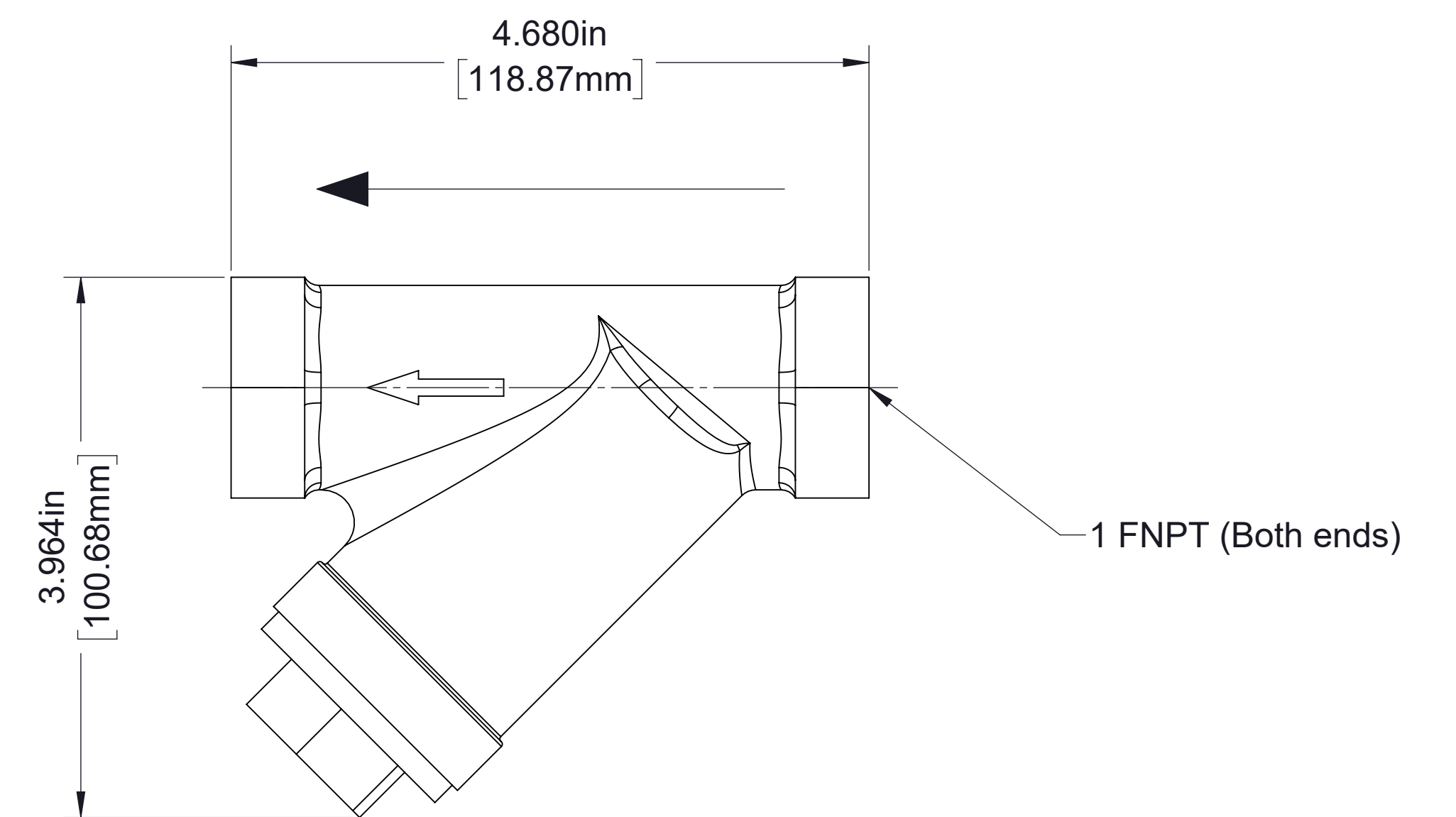

Aquis 6.0

Foam Line Strainers

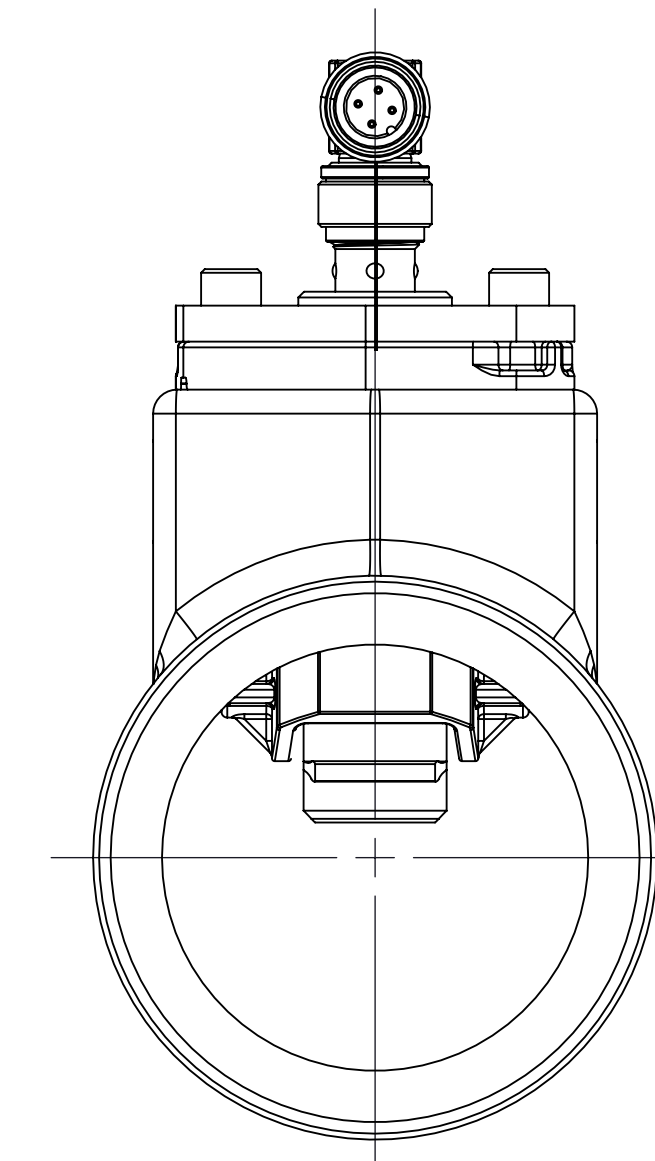
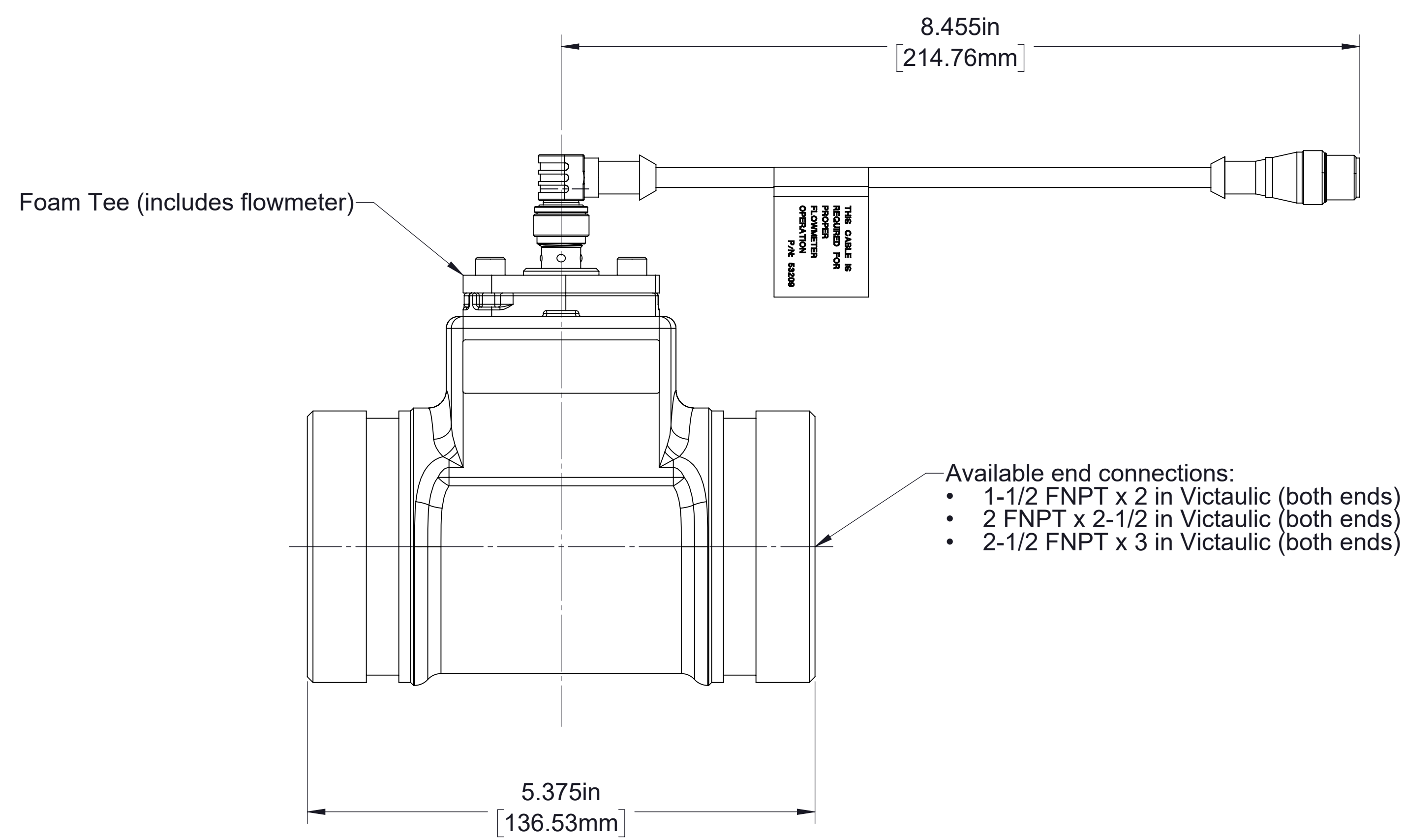

Foam Tee

(Dimensions shown typical for all foam tees)

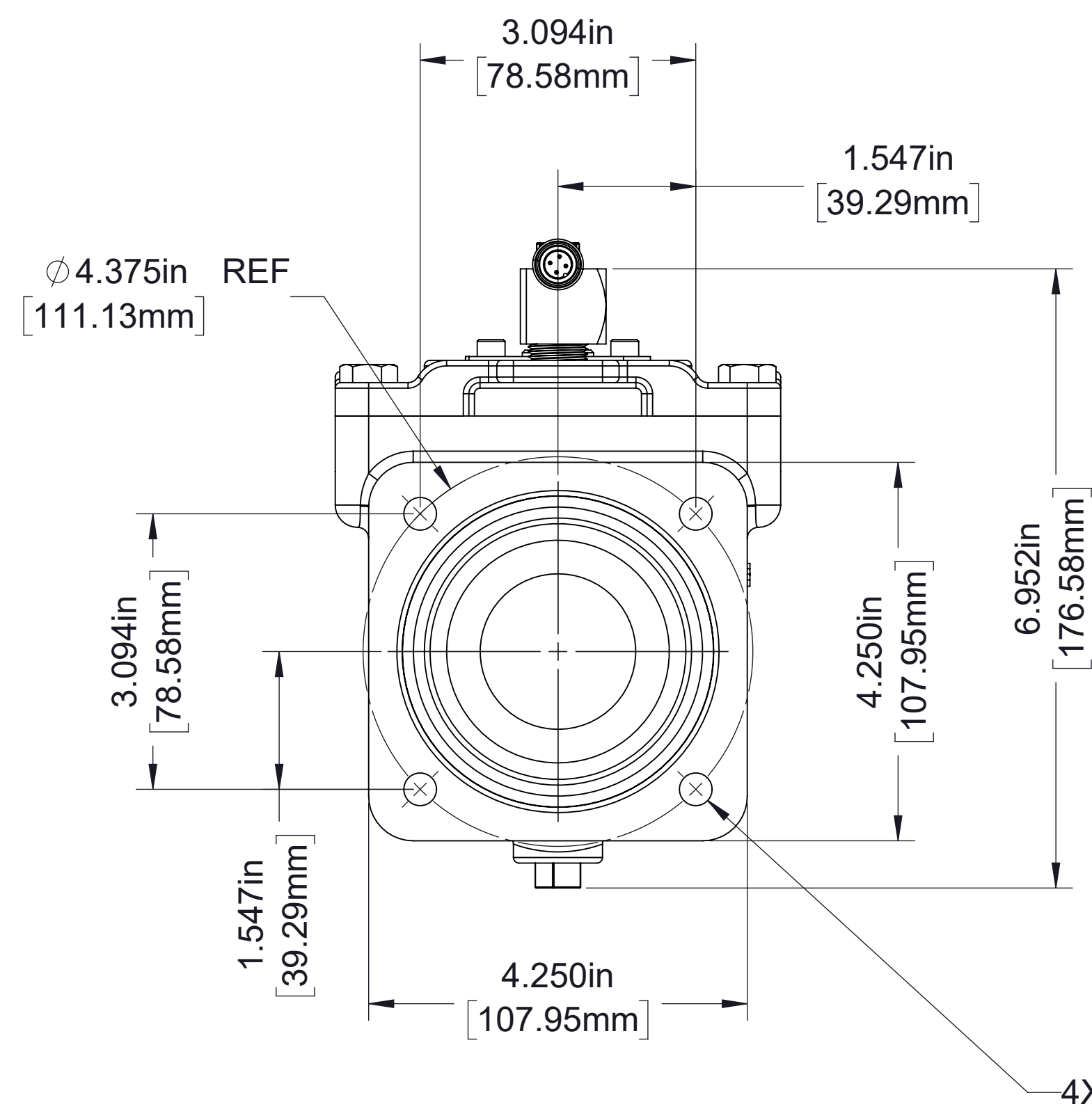

4X 7/16-14 UNC ∇ 1.00in [25.40mm]

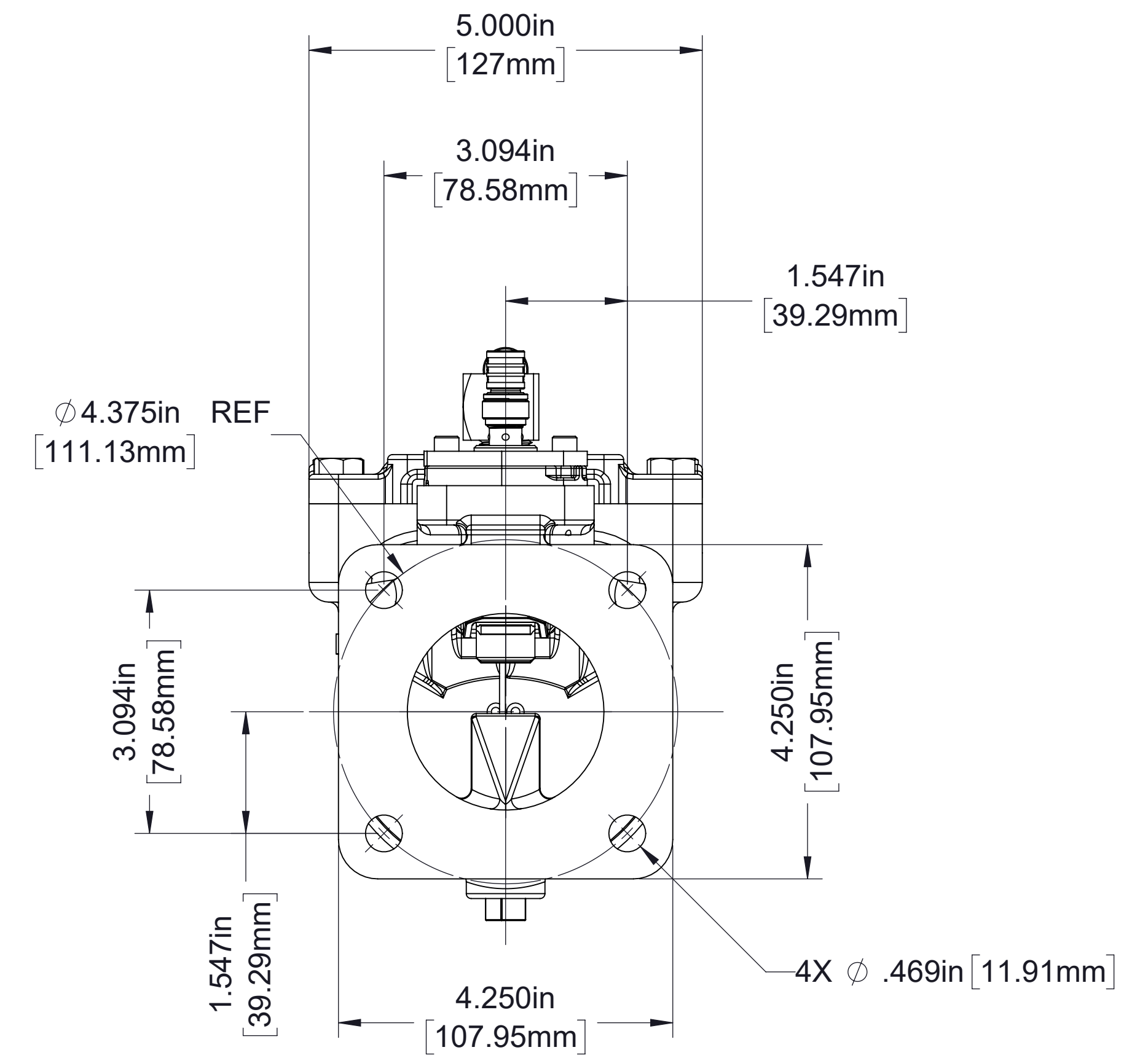
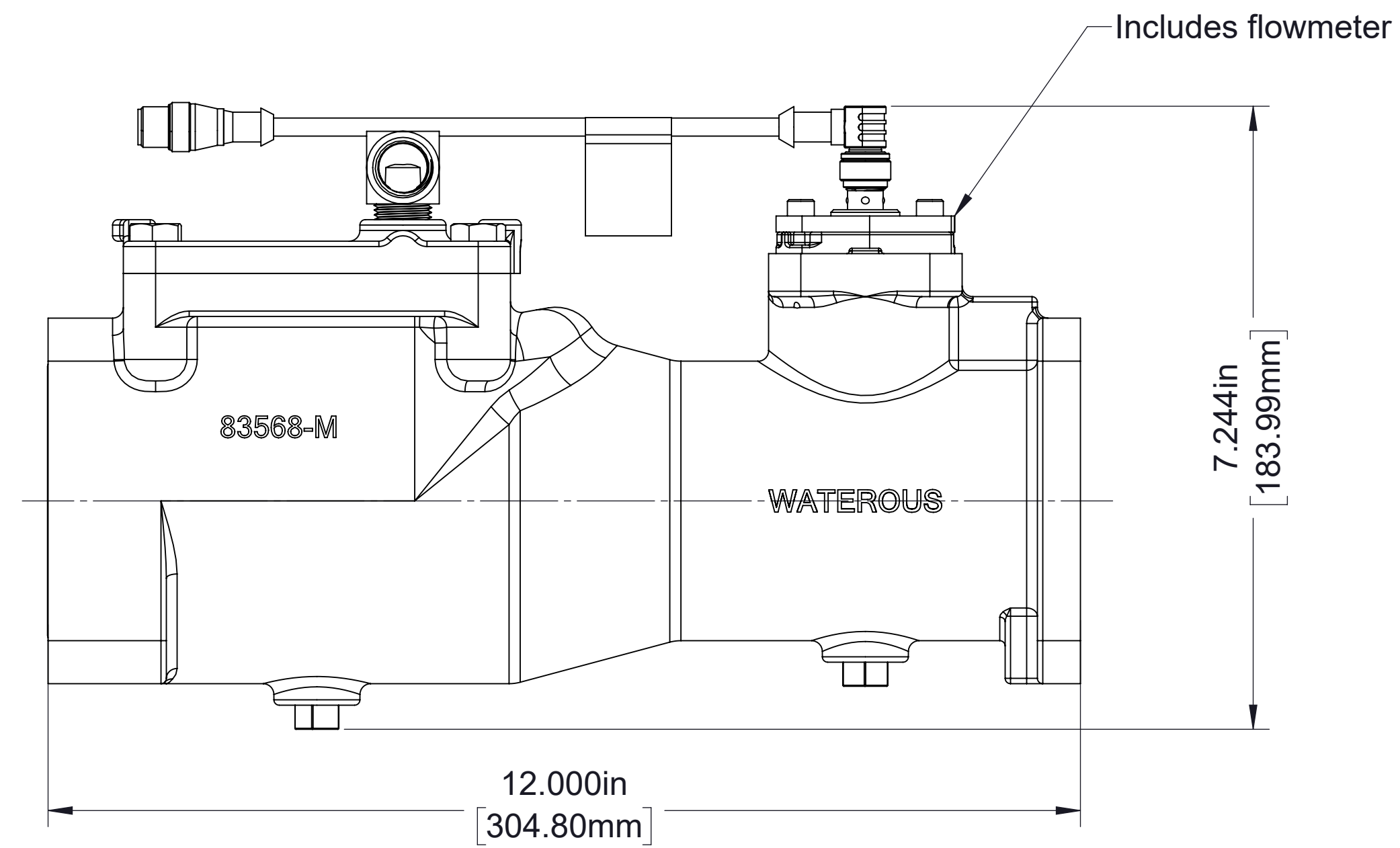

Flow

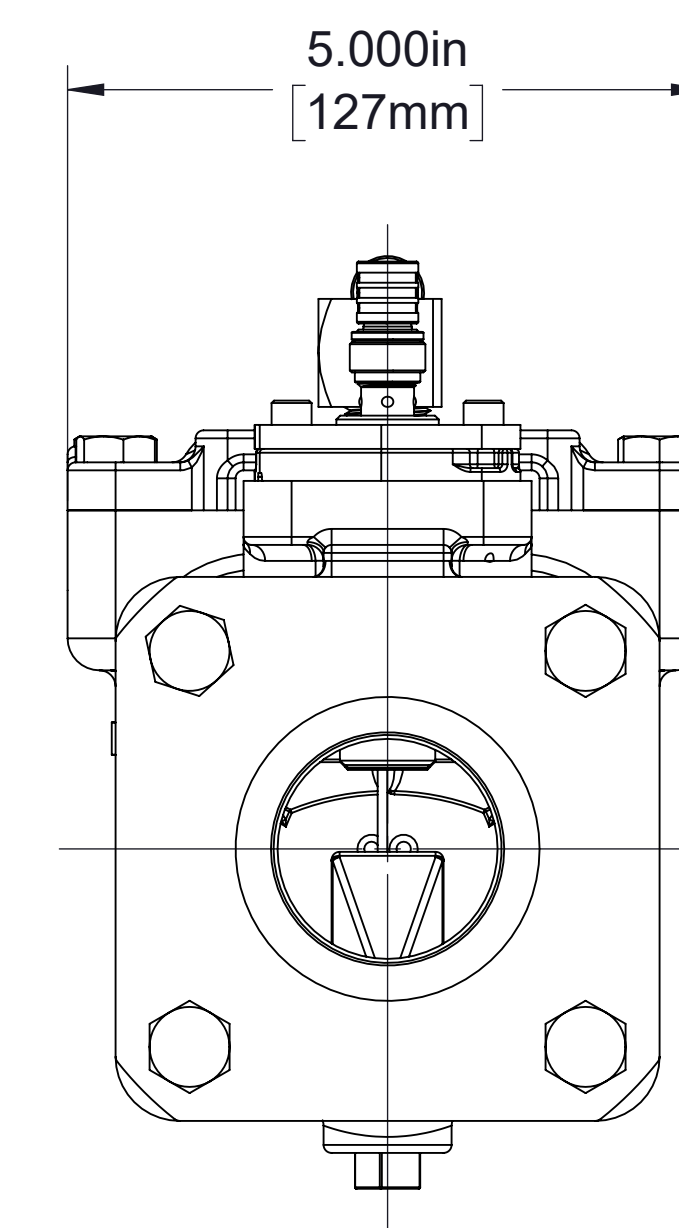
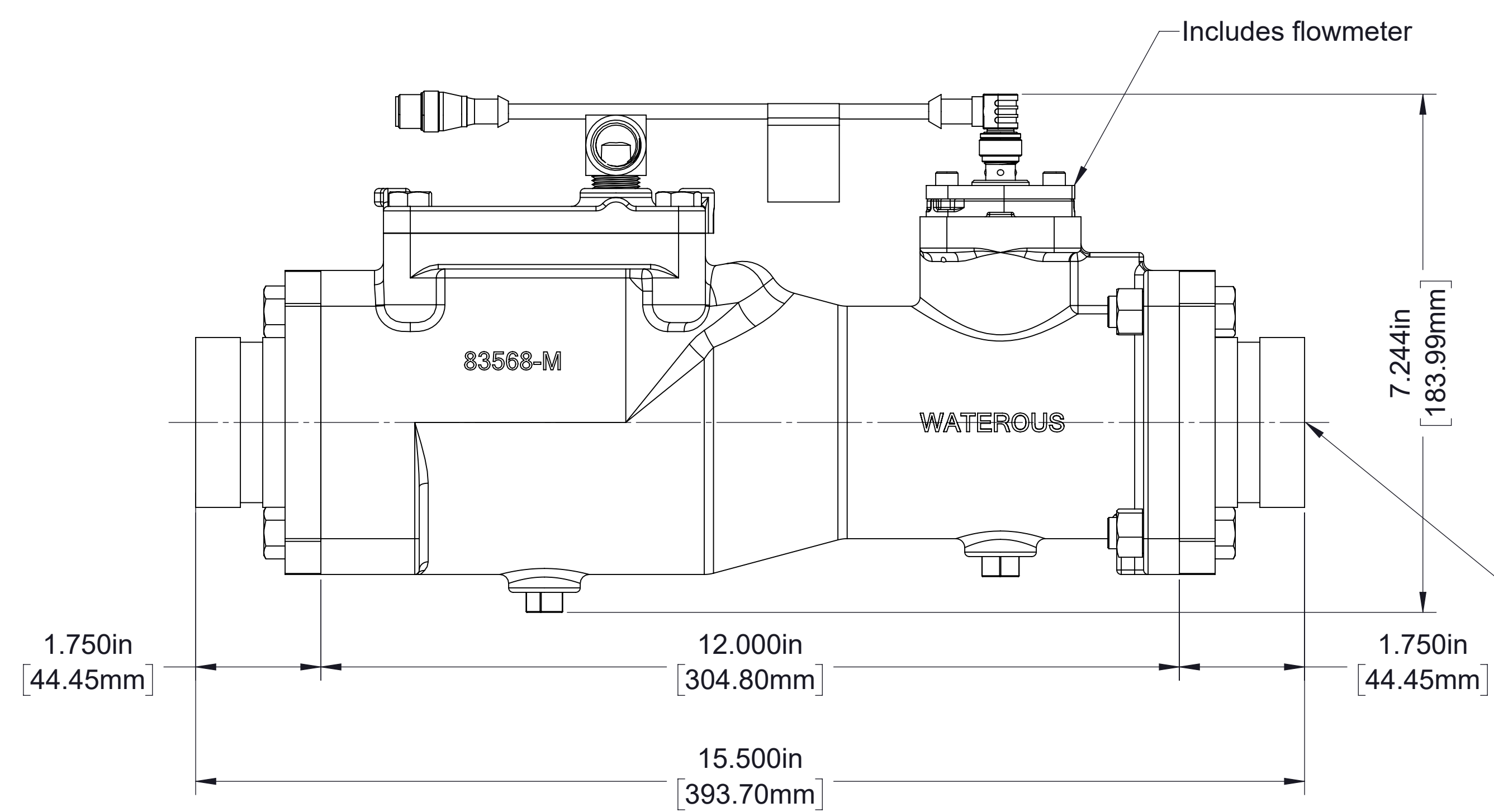
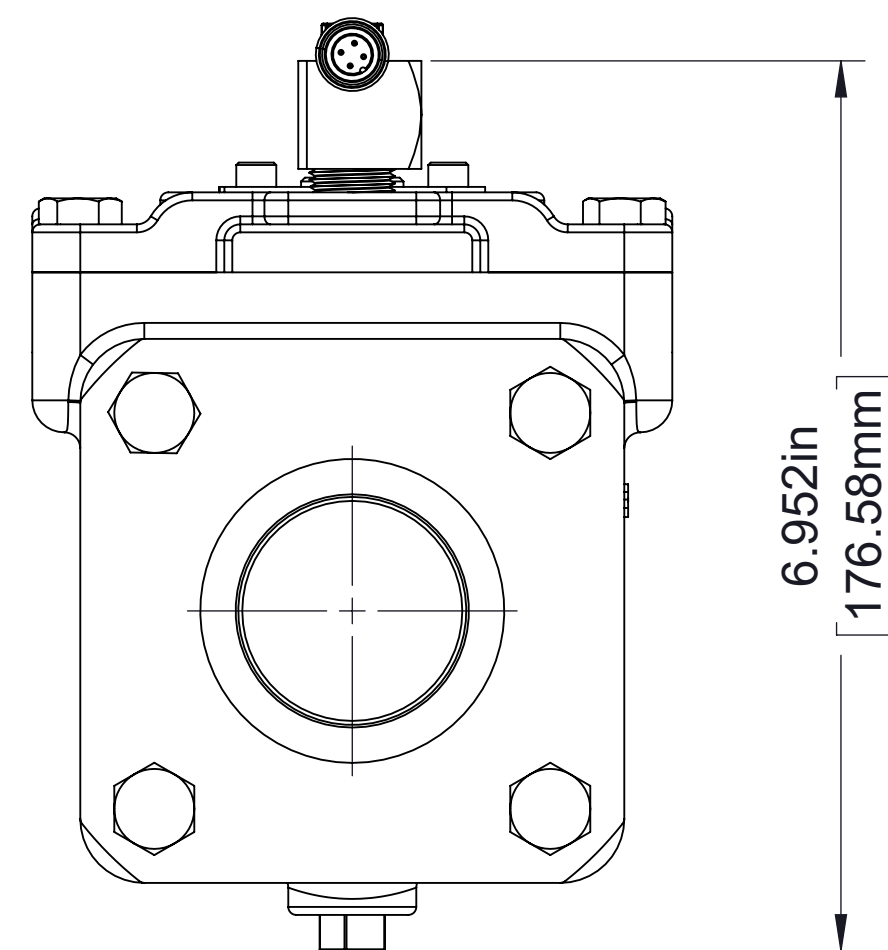

- Available flange adapters:
- 1-1/2 FNPT x 2 in Victaulic (both ends)
 - 2 FNPT x 2-1/2 in Victaulic (both ends)
 - 2-1/2 FNPT x 3 in Victaulic (both ends)

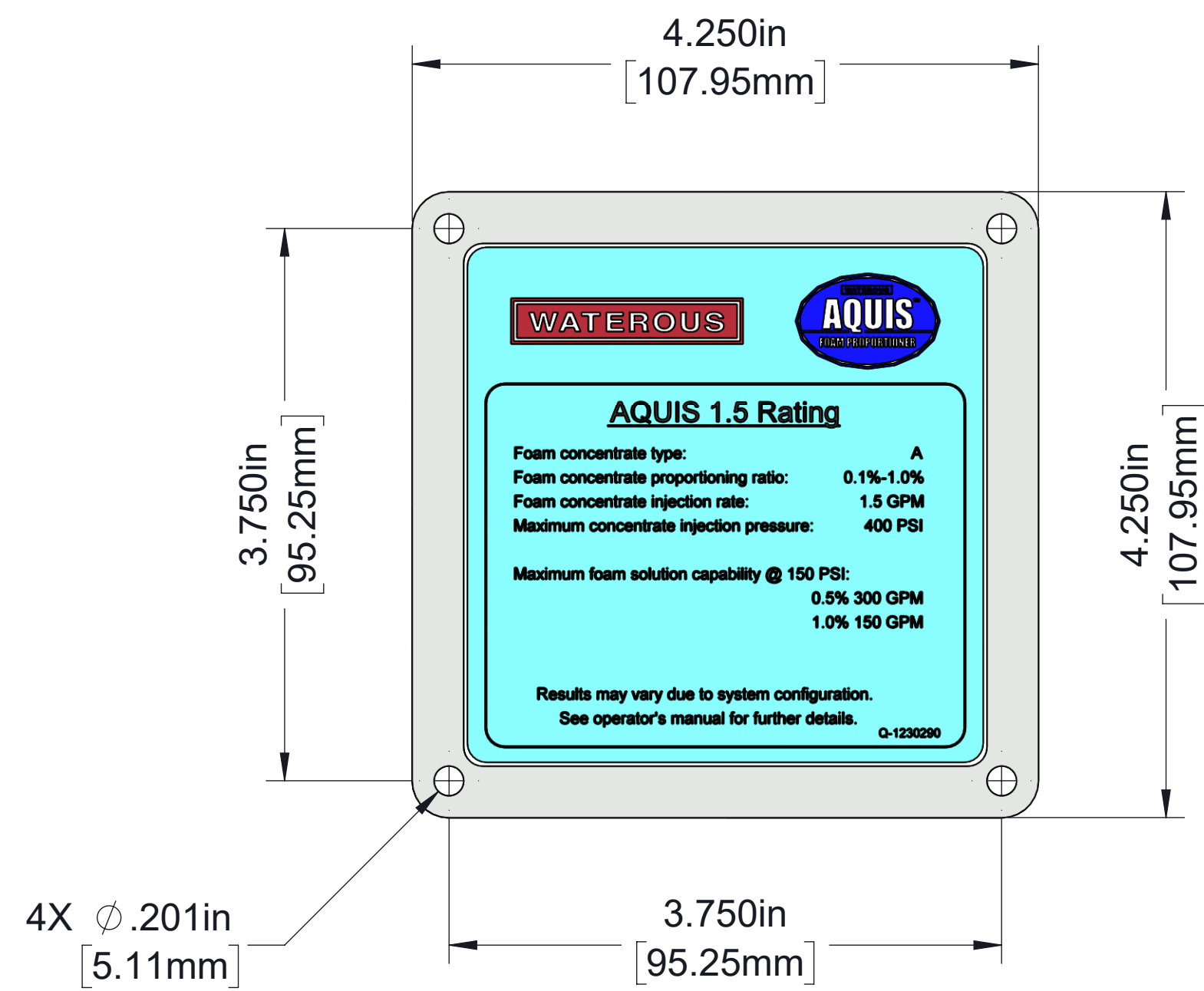

Aquis 1.5 Rating Panel Plate

Order part number:
Q-0315321 (English)
63752 (Chinese)

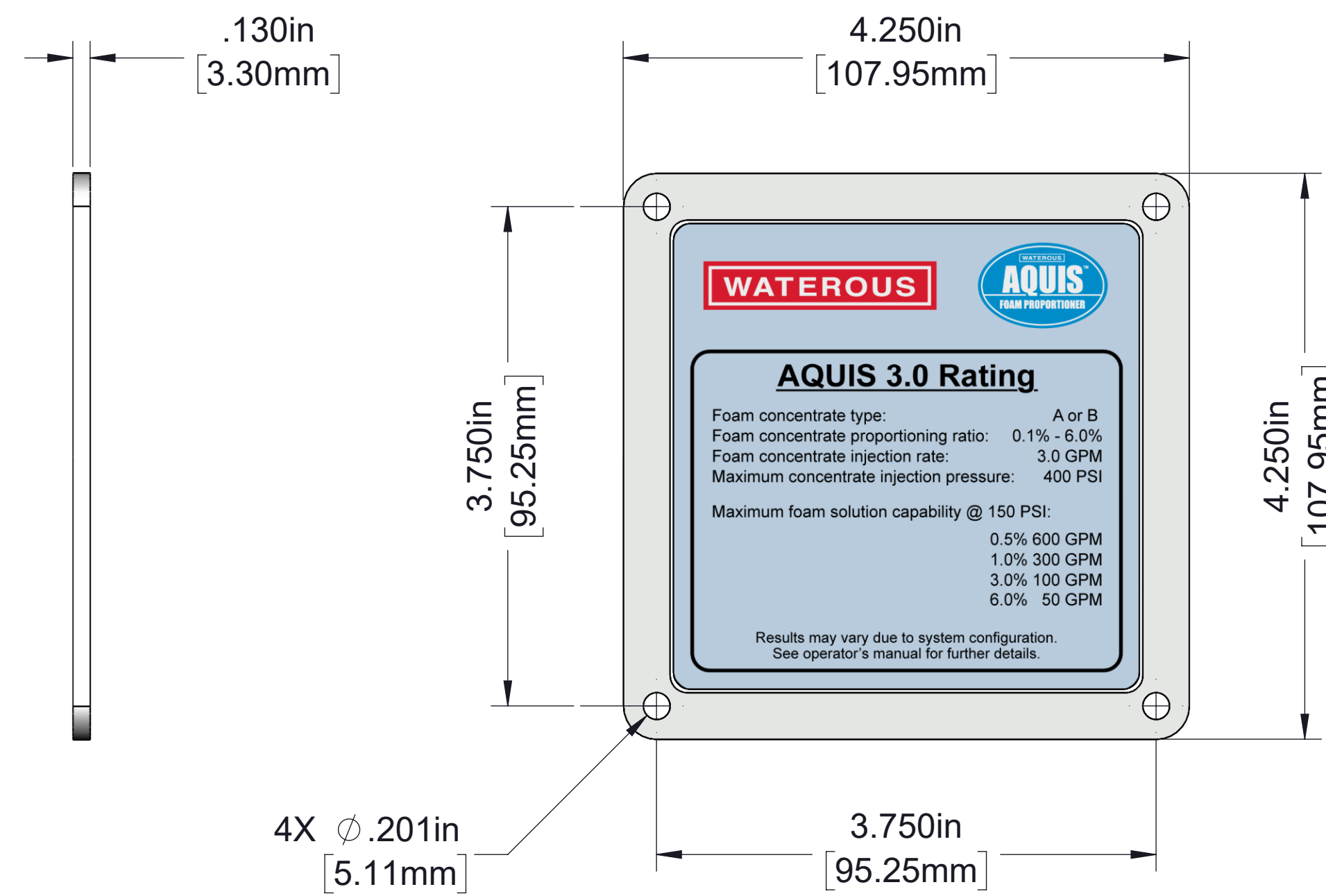

Aquis 3.0 Rating Panel Plate

Order part number:
63812 (English)
63813 (Chinese)

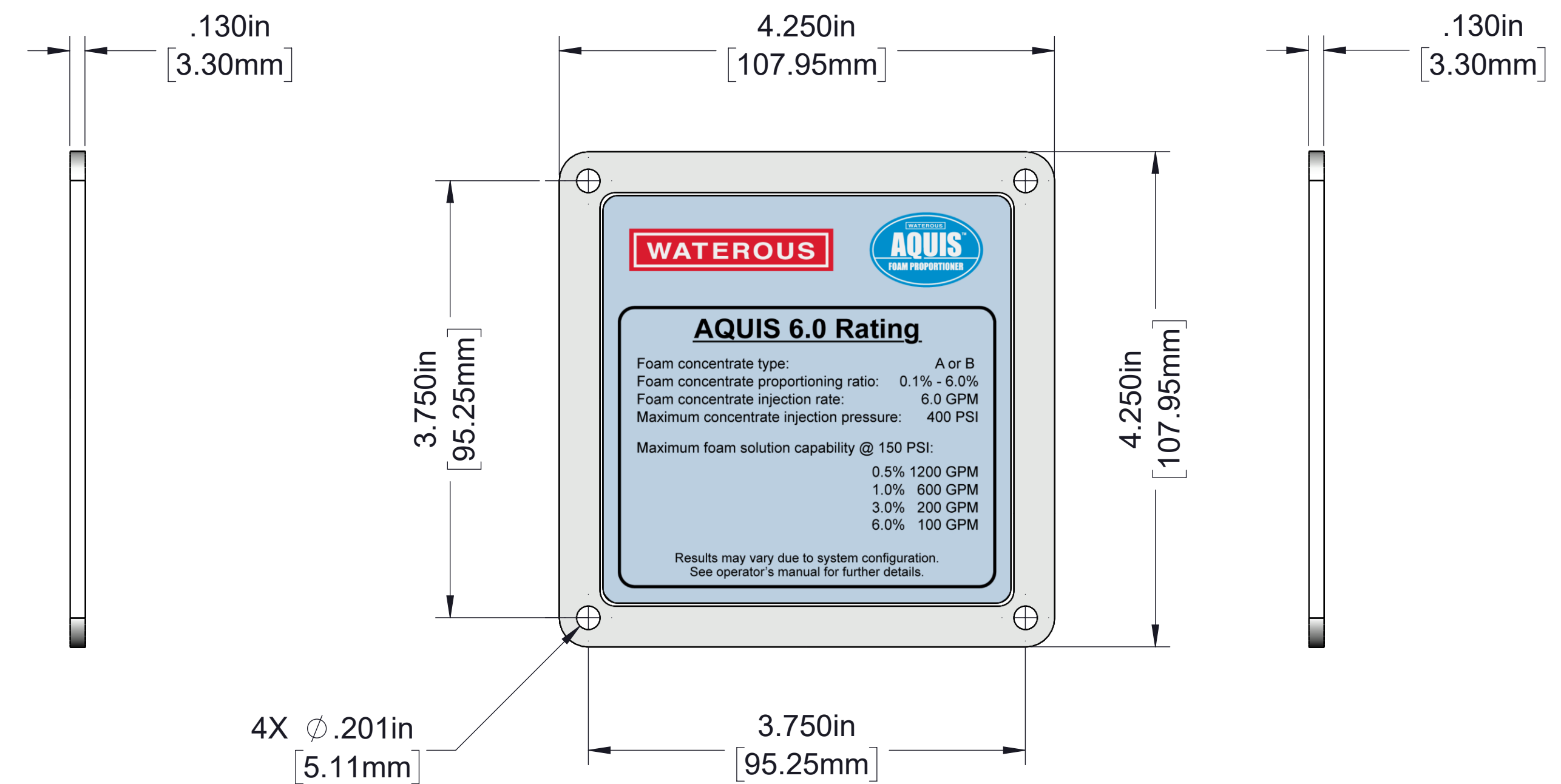

Aquis 6.0 Rating Panel Plate

Order part number:
63814 (English)
63815 (Chinese)

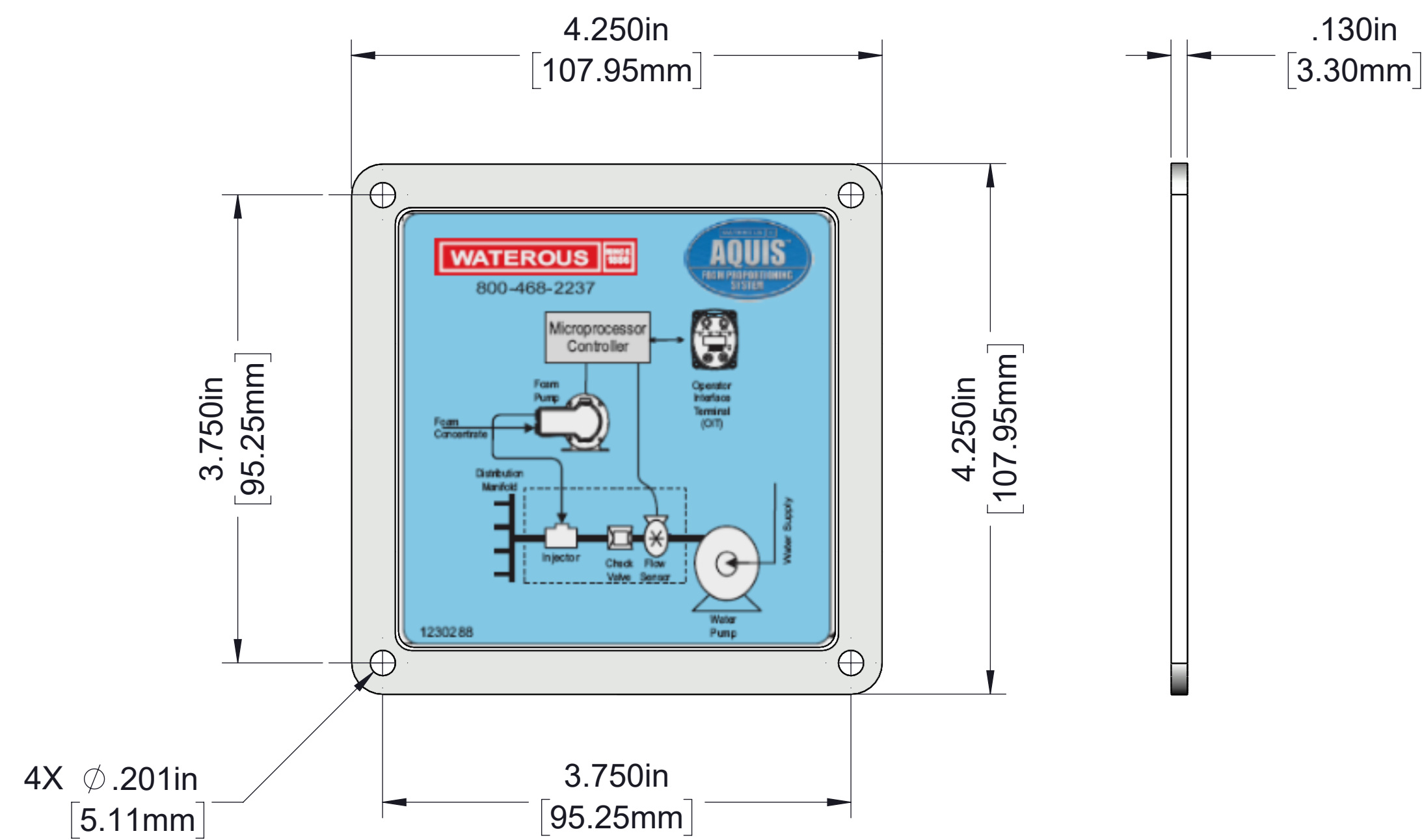

System Schematic Panel Plate (all models)

Order part number:
Q-0315315 (English)
63756 (Chinese)

Optional Panel Plates

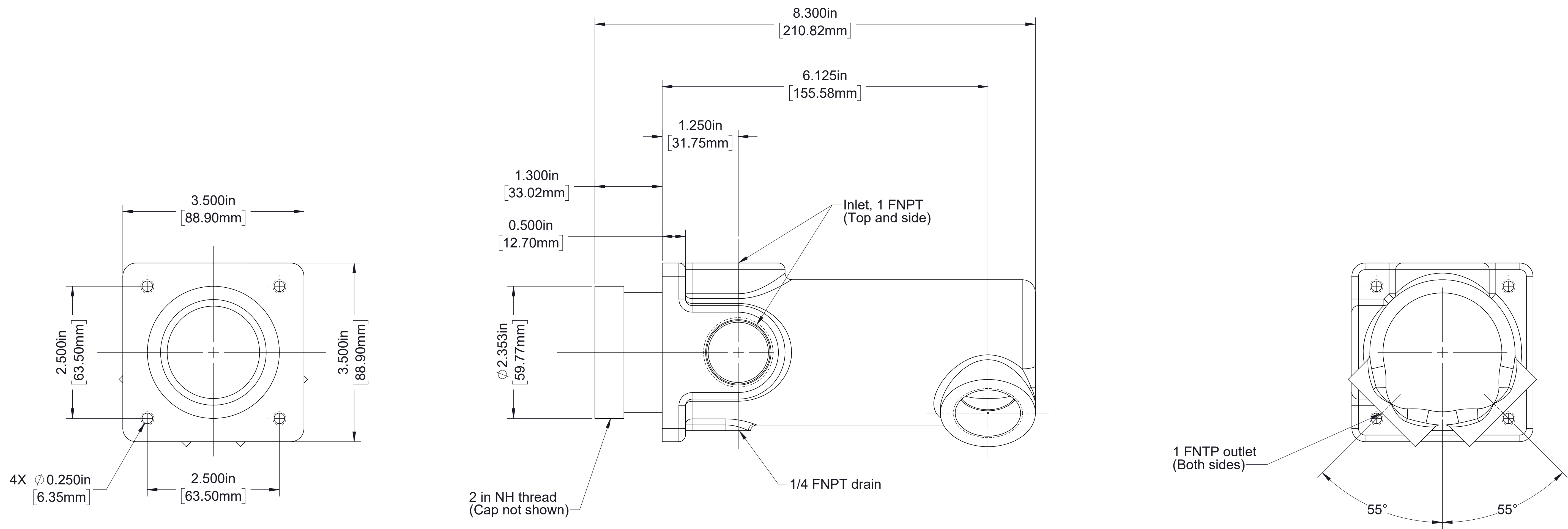

Optional Panel Mounted Foam Line Strainer

Number 10 mesh, includes cap and chain
 Order part number Q-2450011