



Form No. F-2464	Issue Date 10/10/00	Rev. Date 07/19/13
---------------------------	-------------------------------	------------------------------

INTAKE FITTING DIAGRAMS

Intake Fittings List:

Fitting Type	Pump		End Connection		Length	Bottom Facing Flange	Relief Valve Provision	Part Number		See Page	
	Model	Material	Type	Size				Iron	Bronze		
Standard Intake Adapter Flanges (Section 1)	CGG	Iron or Bronze	Threaded	4-1/2 in. NH	15.00 in.	No	Yes	81835	81835-BZ	3	
				5 in. NH	10.50 in.	No	Yes	81833	81833-BZ	2	
					13.50 in.	3-1/2 in. 8-Bolt	No	81913	81913-BZ	10	
					15.00 in.	No	Yes	81836	81836-BZ	4	
				6 in. NH	13.50 in.	No	Yes	81838	81838-BZ	6	
						3-1/2 in. 8-Bolt	No	81914	N/A	11	
	5 in. ANSI	Yes	81841			N/A	7				
	CM, CS	Bronze	Threaded	6 in. NH	15.00 in.	No	Yes	81837	81837-BZ	5	
						3-1/2 in. 8-Bolt	No	81912	81912-BZ	9	
						5 in. ANSI	Yes	81844	81844-BZ	8	
	Flanged	6 in. ANSI	6.75 in.	No	Yes	82188	N/A	20			
				Yes	Yes	82199	N/A	21			
Large Intake Adapter Flanges (Section 2)	CM, CS	Iron	Threaded	5 in. NH	13.50 in.	3-1/2 in. 8-Bolt	No	82768	N/A	26	
					15.00 in.	3-1/2 in. 8-Bolt	No	82767	N/A	25	
				6 in. NH	13.50 in.	3-1/2 in. 8-Bolt	No	81916	N/A	13	
					13.50 in.	No	Yes	82173	82173-BZ	18	
					13.50 in.	5 in. ANSI	Yes	82174	N/A	19	
					15.00 in.	3-1/2 in. 8-Bolt	No	81915	81915-BZ	12	
					15.00 in.	No	Yes	82163	82163-BZ	15	
					15.00 in.	5 in. ANSI	Yes	82166	82166-BZ	17	
				Flanged	6 in. ANSI	6.75 in.	2-1/2 in. 4-Bolt	No	82289	N/A	22
						6.75 in.	No	Yes	82301	N/A	23
	6.75 in.	5 in. ANSI	Yes			82302	N/A	24			
	10.62 in.	3-1/2 in. 8-Bolt	No			82011	82011-BZ	14			
	S101	Iron	Flanged	6 in. ANSI	10.62 in.	No (5 in. Victaulic to Side)	No	83041	N/A	28	
	CM, CS	Iron	Dual Flanged (Pant Leg)	8 in. ANSI	15.85 in.	5 in. Victaulic	No	82952	N/A	27	
	CMU, CSU	Iron or Bronze									

Intake Fitting: 81833/81833-BZ

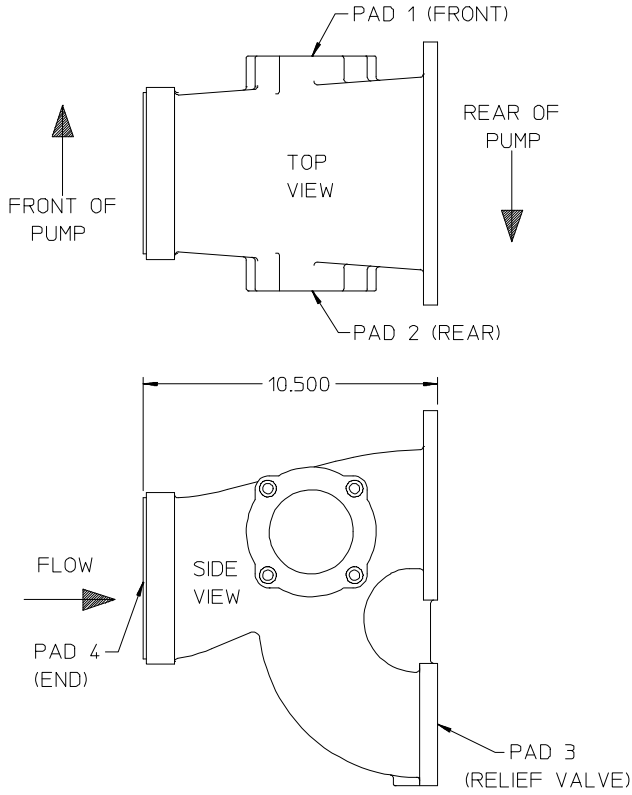

Pad	Machined	Install Auxiliary Fittings
1 (Front)	2-1/2 in. 4-Bolt	Type 1
2 (Rear)	2-1/2 in. 4-Bolt	Type 1
3 (R.V.)	3 in. R.V.	Type 14
4 (End)	5 in. NH	Type 23

Left Side Mounting

Pad	Machined	Install Auxiliary Fittings
1 (Rear)	2-1/2 in. 4-Bolt	Type 1
2 (Front)	2-1/2 in. 4-Bolt	Type 1
3 (R.V.)	3 in. R.V.	Type 14
4 (End)	5 in. NH	Type 23

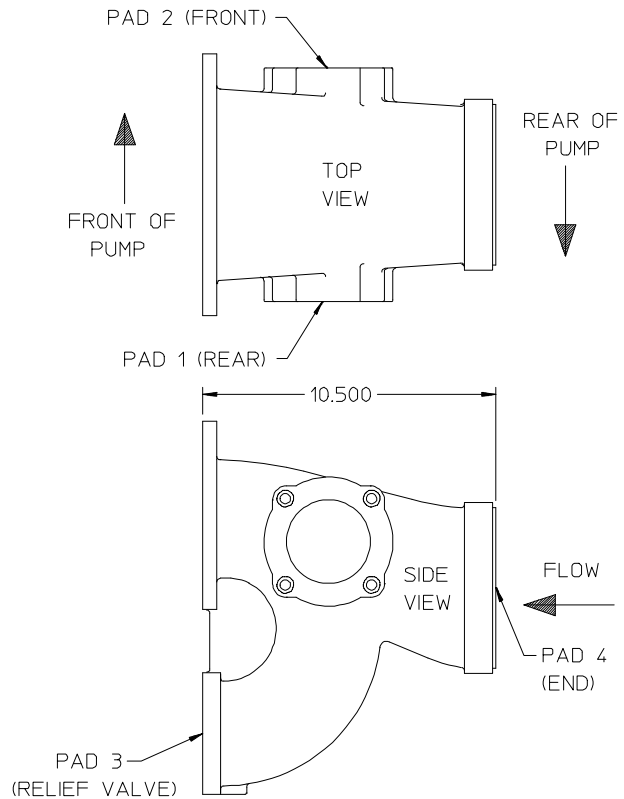

Right Side Mounting

Intake Fitting: 81835/81835-BZ

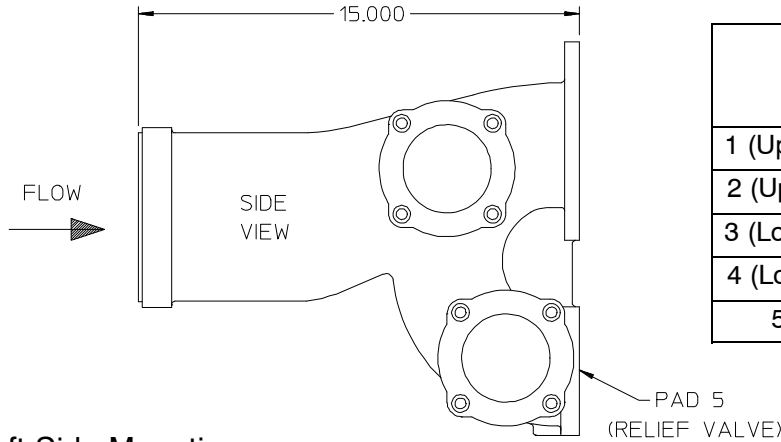
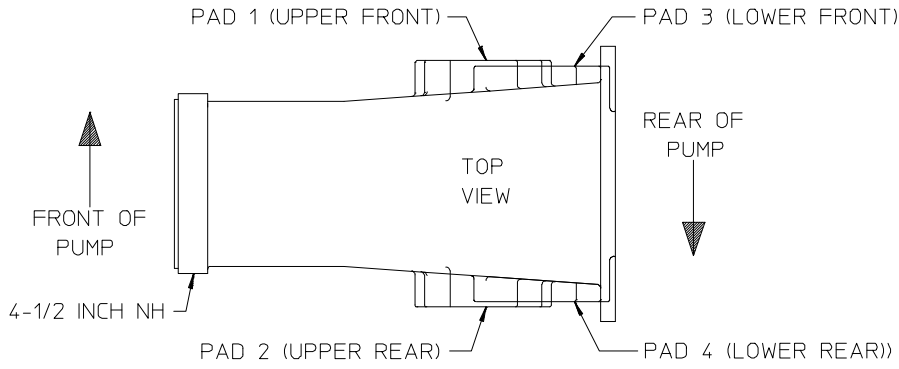

Pad	Machined	Install Auxiliary Fittings
1 (Upper Front)	2-1/2 in. 4-Bolt	Type 1
2 (Upper Rear)	2-1/2 in. 4-Bolt	Type 1
3 (Lower Front)	2-1/2 in. 4-Bolt	Type 1
4 (Lower Rear)	2-1/2 in. 4-Bolt	Type 1
5 (R.V.)	3 in. R.V.	Type 14

Left Side Mounting

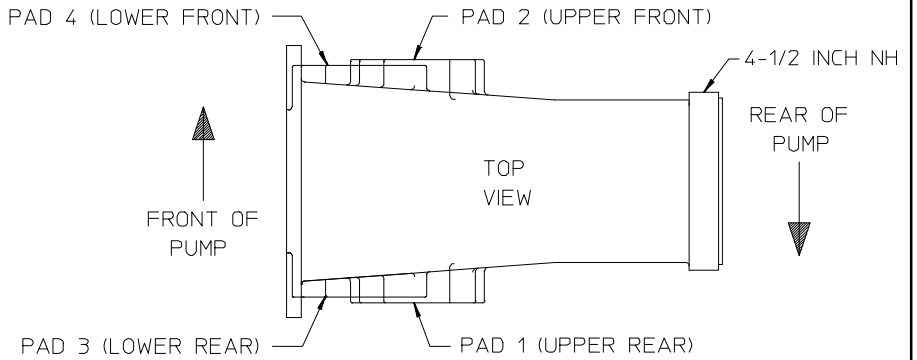

Pad	Machined	Install Auxiliary Fittings
1 (Upper Rear)	2-1/2 in. 4-Bolt	Type 1
2 (Upper Front)	2-1/2 in. 4-Bolt	Type 1
3 (Lower Rear)	2-1/2 in. 4-Bolt	Type 1
4 (Lower Front)	2-1/2 in. 4-Bolt	Type 1
5 (R.V.)	3 in. R.V.	Type 14

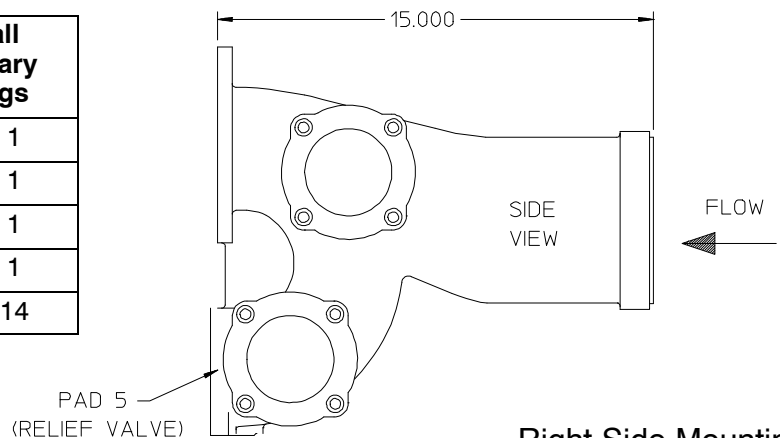

Right Side Mounting

Intake Fitting: 81836/81836-BZ

Left Side Mounting

Diagram labels: PAD 1 (UPPER FRONT), PAD 3 (LOWER FRONT), REAR OF PUMP, TOP VIEW, FRONT OF PUMP, PAD 2 (UPPER REAR), PAD 4 (LOWER REAR), 15.000, FLOW, PAD 6 (END), SIDE VIEW, PAD 5 (RELIEF VALVE).

Pad	Machined	Install Auxiliary Fittings
1 (Upper Front)	2-1/2 in. 4-Bolt	Type 1
2 (Upper Rear)	2-1/2 in. 4-Bolt	Type 1
3 (Lower Front)	2-1/2 in. 4-Bolt	Type 1
4 (Lower Rear)	2-1/2 in. 4-Bolt	Type 1
5 (R.V.)	3 in. R.V.	Type 14
6 (End)	5 in. NH	Type 23

Right Side Mounting

Diagram labels: PAD 4 (LOWER FRONT), PAD 2 (UPPER FRONT), REAR OF PUMP, TOP VIEW, FRONT OF PUMP, PAD 3 (LOWER REAR), PAD 1 (UPPER REAR), 15.000, FLOW, PAD 6 (END), SIDE VIEW, PAD 5 (RELIEF VALVE).

Pad	Machined	Install Auxiliary Fittings
1 (Upper Rear)	2-1/2 in. 4-Bolt	Type 1
2 (Upper Front)	2-1/2 in. 4-Bolt	Type 1
3 (Lower Rear)	2-1/2 in. 4-Bolt	Type 1
4 (Lower Front)	2-1/2 in. 4-Bolt	Type 1
5 (R.V.)	3 in. R.V.	Type 14
6 (End)	5 in. NH	Type 23

Intake Fitting: 81837/81837-BZ

Left Side Mounting

Pad	Machined	Install Auxiliary Fittings
1 (Upper Front)	2-1/2 in. 4-Bolt	Type 1
2 (Upper Rear)	2-1/2 in. 4-Bolt	Type 1
3 (Lower Front)	2-1/2 in. 4-Bolt	Type 1
4 (Lower Rear)	2-1/2 in. 4-Bolt	Type 1
5 (R.V.)	3 in. R.V.	Type 14
6 (End)	6 in. NH	Type 13

Right Side Mounting

Pad	Machined	Install Auxiliary Fittings
1 (Upper Rear)	2-1/2 in. 4-Bolt	Type 1
2 (Upper Front)	2-1/2 in. 4-Bolt	Type 1
3 (Lower Rear)	2-1/2 in. 4-Bolt	Type 1
4 (Lower Front)	2-1/2 in. 4-Bolt	Type 1
5 (R.V.)	3 in. R.V.	Type 14
6 (End)	6 in. NH	Type 13

Intake Fitting: 81838/81838-BZ

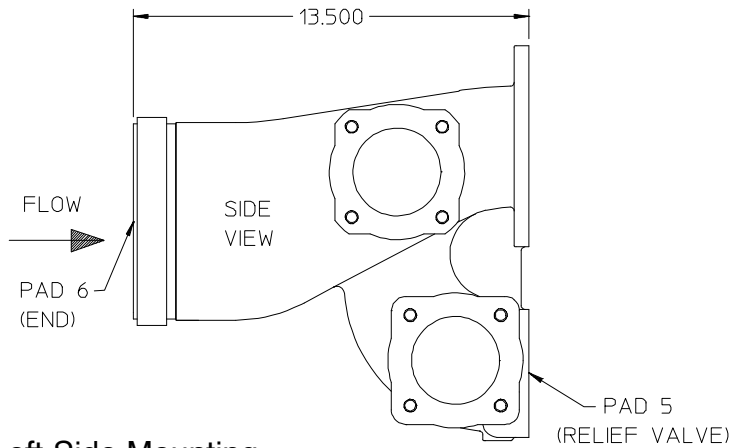
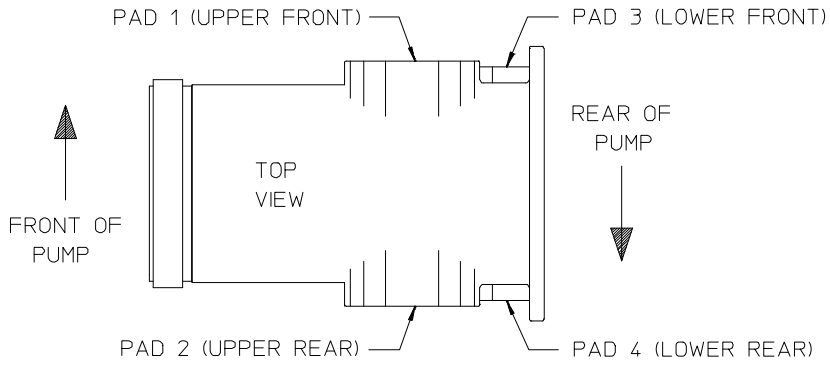

Pad	Machined	Install Auxiliary Fittings
1 (Upper Front)	2-1/2 in. 4-Bolt	Type 1
2 (Upper Rear)	2-1/2 in. 4-Bolt	Type 1
3 (Lower Front)	2-1/2 in. 4-Bolt	Type 1
4 (Lower Rear)	2-1/2 in. 4-Bolt	Type 1
5 (R.V.)	3 in. R.V.	Type 14
6 (End)	6 in. NH	Type 13

Left Side Mounting

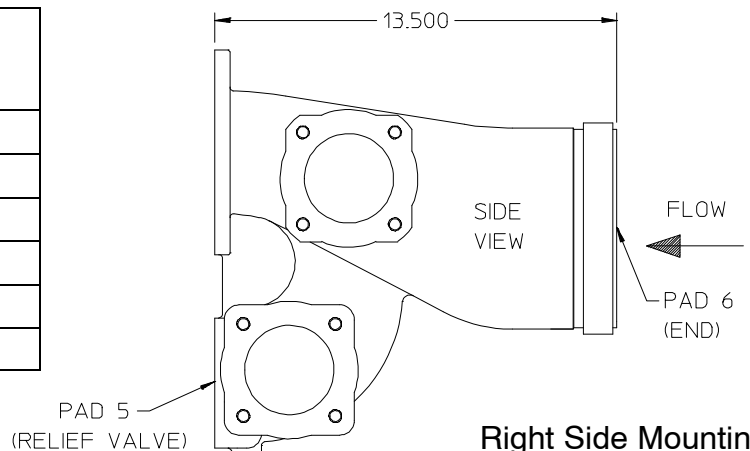
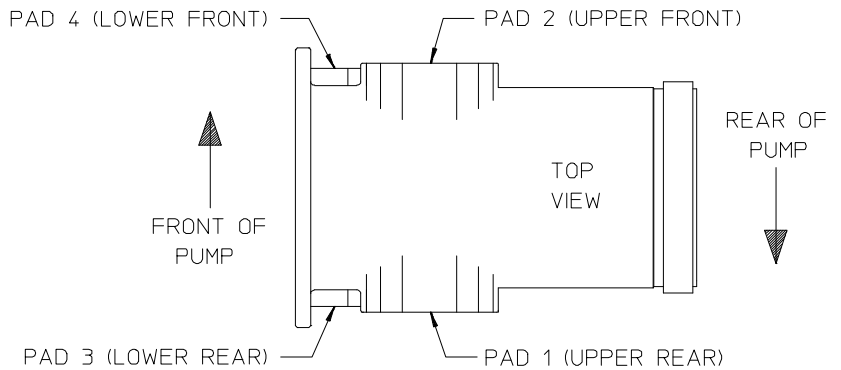

Pad	Machined	Install Auxiliary Fittings
1 (Upper Rear)	2-1/2 in. 4-Bolt	Type 1
2 (Upper Front)	2-1/2 in. 4-Bolt	Type 1
3 (Lower Rear)	2-1/2 in. 4-Bolt	Type 1
4 (Lower Front)	2-1/2 in. 4-Bolt	Type 1
5 (R.V.)	3 in. R.V.	Type 14
6 (End)	6 in. NH	Type 13

Right Side Mounting

Intake Fitting: 81841

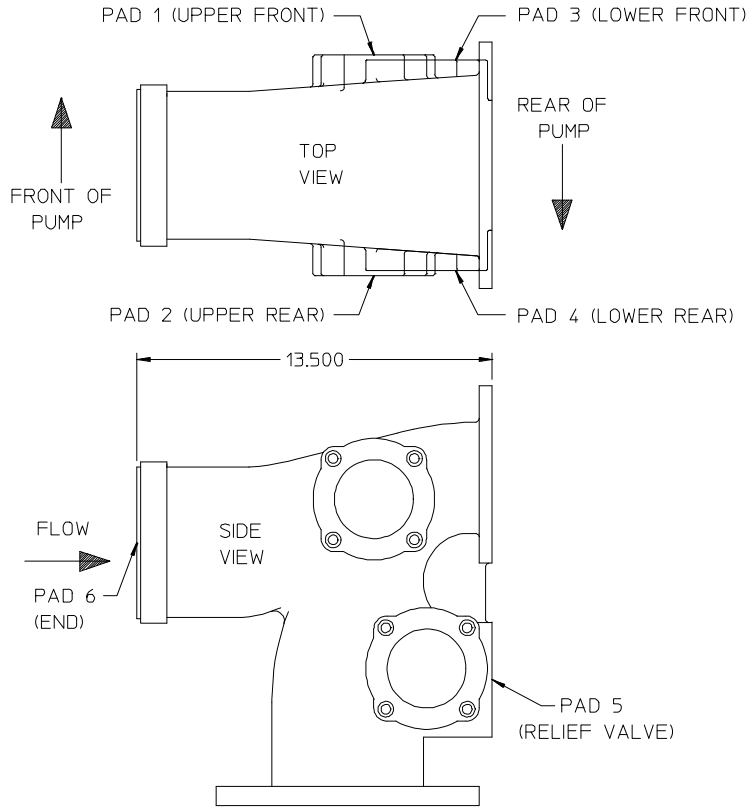

Pad	Machined	Install Auxiliary Fittings
1 (Upper Front)	2-1/2 in. 4-Bolt	Type 1
2 (Upper Rear)	2-1/2 in. 4-Bolt	Type 1
3 (Lower Front)	2-1/2 in. 4-Bolt	Type 1
4 (Lower Rear)	2-1/2 in. 4-Bolt	Type 1
5 (R.V.)	3 in. R.V.	Type 14
6 (End)	6 in. NH	Type 13

Left Side Mounting

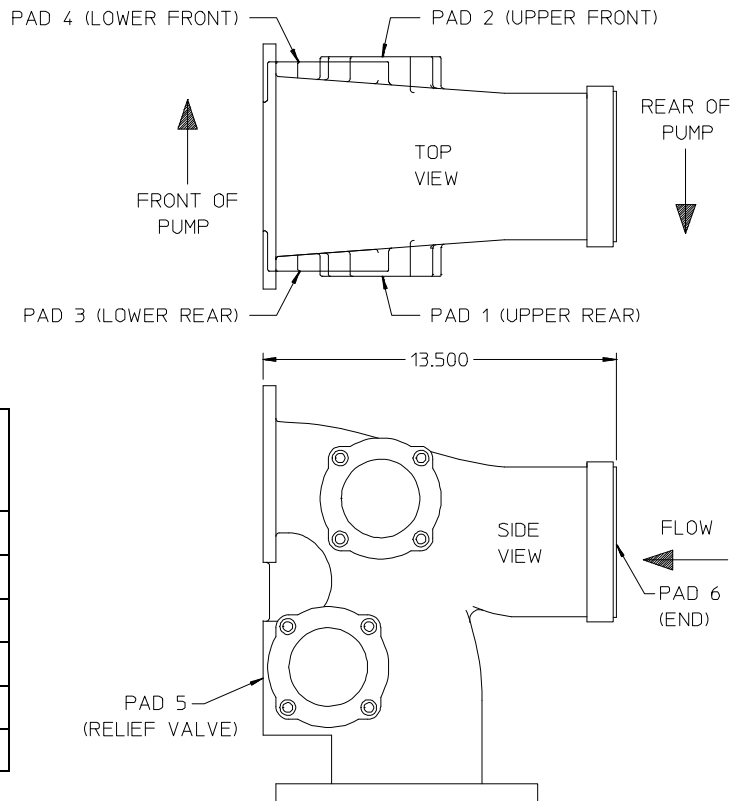

Pad	Machined	Install Auxiliary Fittings
1 (Upper Rear)	2-1/2 in. 4-Bolt	Type 1
2 (Upper Front)	2-1/2 in. 4-Bolt	Type 1
3 (Lower Rear)	2-1/2 in. 4-Bolt	Type 1
4 (Lower Front)	2-1/2 in. 4-Bolt	Type 1
5 (R.V.)	3 in. R.V.	Type 14
6 (End)	6 in. NH	Type 13

Right Side Mounting

Intake Fitting: 81844/81844-BZ

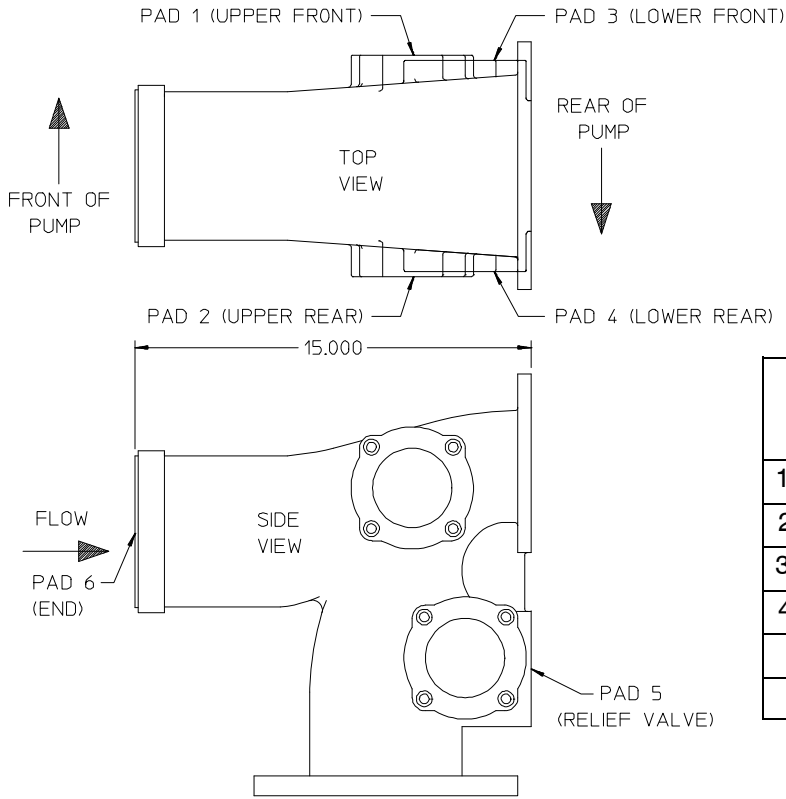

Pad	Machined	Install Auxiliary Fittings
1 (Upper Front)	2-1/2 in. 4-Bolt	Type 1
2 (Upper Rear)	2-1/2 in. 4-Bolt	Type 1
3 (Lower Front)	2-1/2 in. 4-Bolt	Type 1
4 (Lower Rear)	2-1/2 in. 4-Bolt	Type 1
5 (R.V.)	3 in. R.V.	Type 14
6 (End)	6 in. NH	Type 13

Left Side Mounting

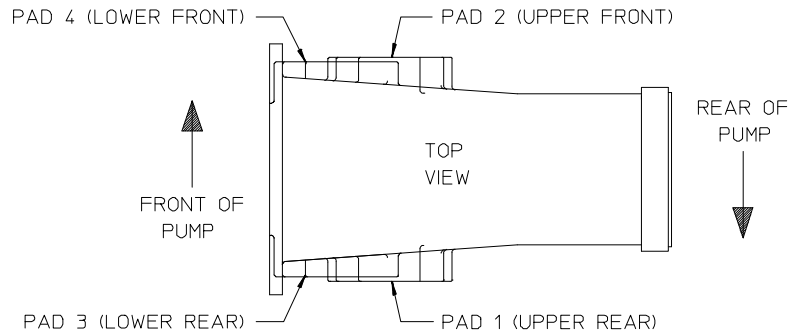

Pad	Machined	Install Auxiliary Fittings
1 (Upper Rear)	2-1/2 in. 4-Bolt	Type 1
2 (Upper Front)	2-1/2 in. 4-Bolt	Type 1
3 (Lower Rear)	2-1/2 in. 4-Bolt	Type 1
4 (Lower Front)	2-1/2 in. 4-Bolt	Type 1
5 (R.V.)	3 in. R.V.	Type 14
6 (End)	6 in. NH	Type 13

PAD 5 (RELIEF VALVE)

Right Side Mounting

Intake Fitting: 81912/81912-BZ

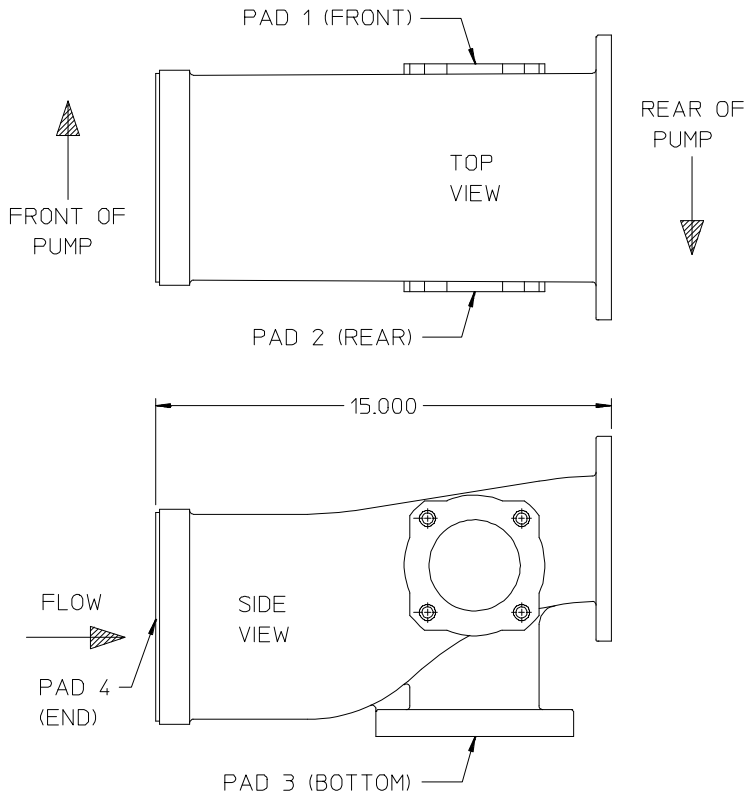

Pad	Machined	Install Auxiliary Fittings
1 (Front)	2-1/2 in. 4-Bolt	Type 1
2 (Rear)	2-1/2 in. 4-Bolt	Type 1
3 (Bottom)	3-1/2 in. 8-Bolt	Type 8
4 (End)	6 in. NH	Type 13

Left Side Mounting

Pad	Machined	Install Auxiliary Fittings
1 (Rear)	2-1/2 in. 4-Bolt	Type 1
2 (Front)	2-1/2 in. 4-Bolt	Type 1
3 (Bottom)	3-1/2 in. 8-Bolt	Type 8
4 (End)	6 in. NH	Type 13

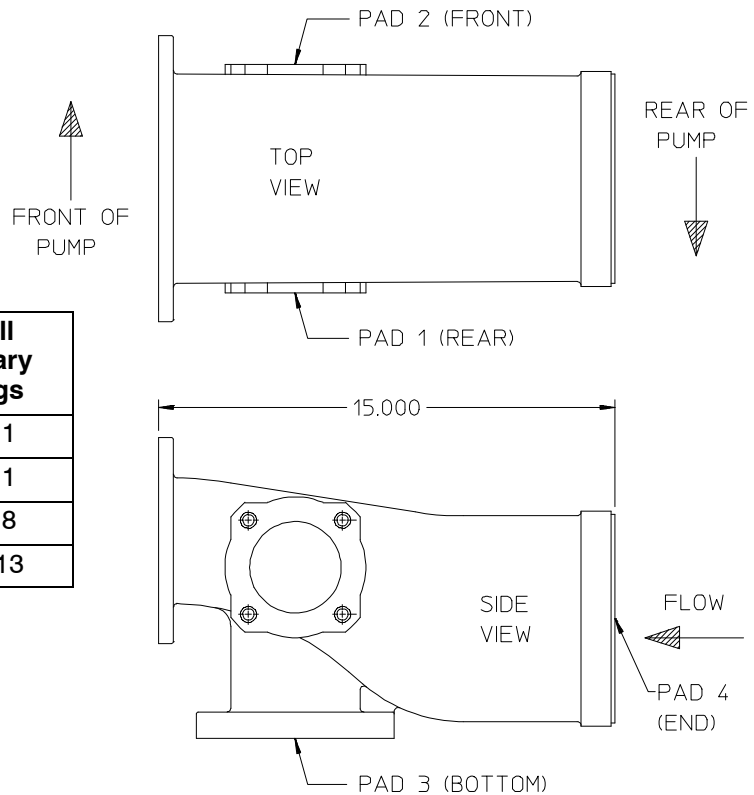

Right Side Mounting

Intake Fitting: 81913/81913-BZ

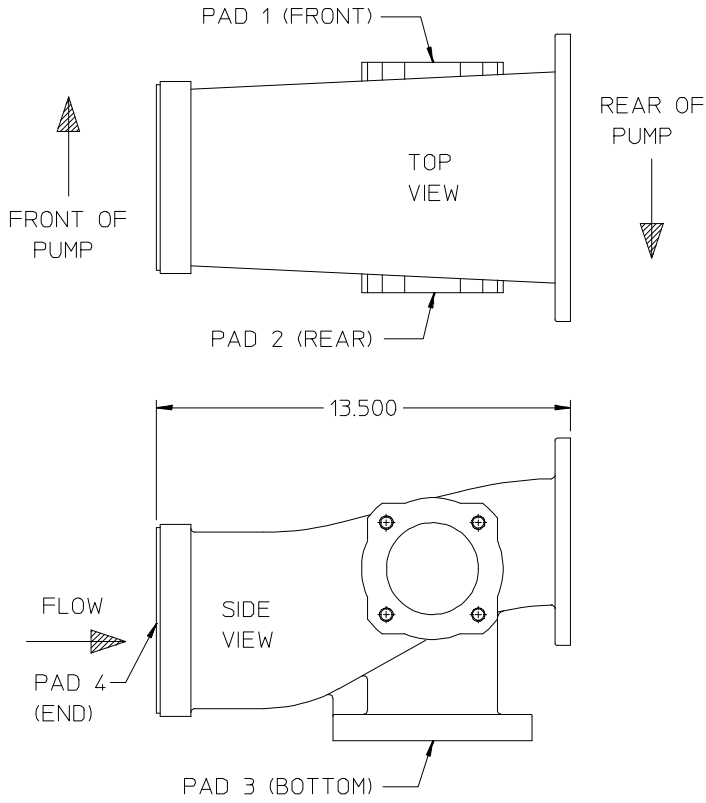

Pad	Machined	Install Auxiliary Fittings
1 (Front)	2-1/2 in. 4-Bolt	Type 1
2 (Rear)	2-1/2 in. 4-Bolt	Type 1
3 (Bottom)	3-1/2 in. 8-Bolt	Type 8
4 (End)	5 in. NH	Type 23

Left Side Mounting

Pad	Machined	Install Auxiliary Fittings
1 (Rear)	2-1/2 in. 4-Bolt	Type 1
2 (Front)	2-1/2 in. 4-Bolt	Type 1
3 (Bottom)	3-1/2 in. 8-Bolt	Type 8
4 (End)	5 in. NH	Type 23

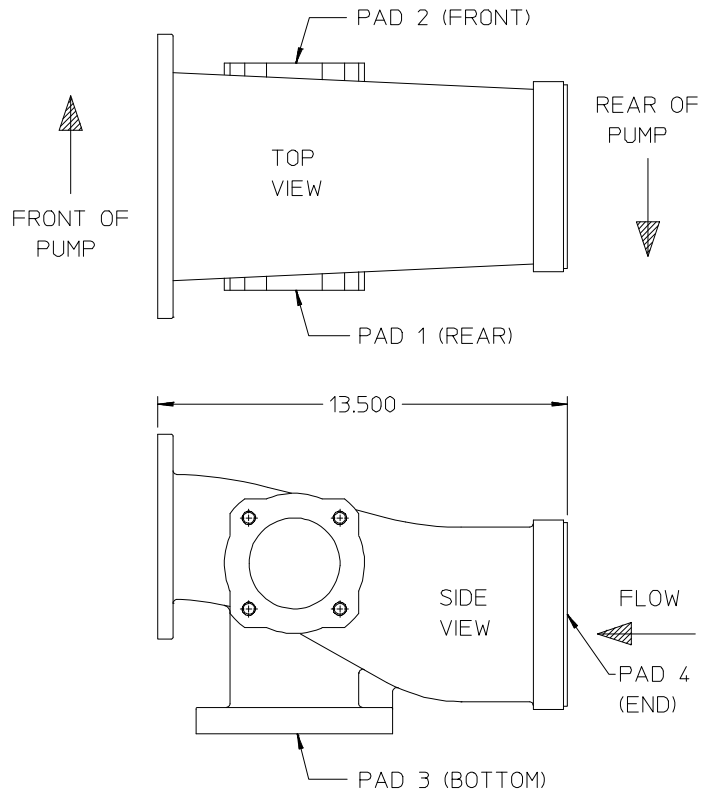

Right Side Mounting

Intake Fitting: 81914

Pad	Machined	Install Auxiliary Fittings
1 (Front)	2-1/2 in. 4-Bolt	Type 1
2 (Rear)	2-1/2 in. 4-Bolt	Type 1
3 (Bottom)	3-1/2 in. 8-Bolt	Type 8
4 (End)	6 in. NH	Type 13

Left Side Mounting

Pad	Machined	Install Auxiliary Fittings
1 (Rear)	2-1/2 in. 4-Bolt	Type 1
2 (Front)	2-1/2 in. 4-Bolt	Type 1
3 (Bottom)	3-1/2 in. 8-Bolt	Type 8
4 (End)	6 in. NH	Type 13

Right Side Mounting

Intake Fitting: 81915/81915-BZ

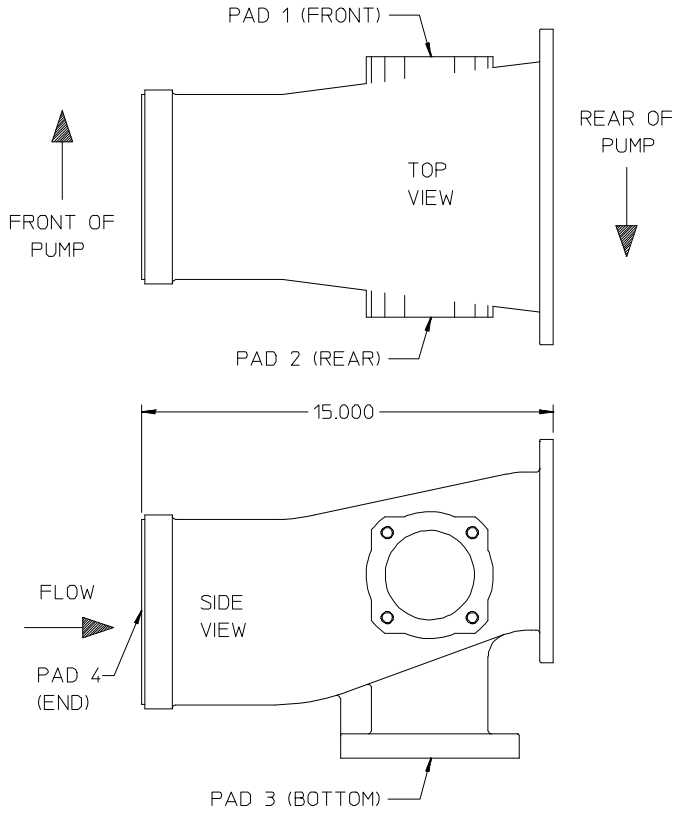

Left Side Mounting

Pad	Machined	Install Auxiliary Fittings
1 (Front)	2-1/2 in. 4-Bolt	Type 1
2 (Rear)	2-1/2 in. 4-Bolt	Type 1
3 (Bottom)	3-1/2 in. 8-Bolt	Type 8
4 (End)	6 in. NH	Type 13

Pad	Machined	Install Auxiliary Fittings
1 (Rear)	2-1/2 in. 4-Bolt	Type 1
2 (Front)	2-1/2 in. 4-Bolt	Type 1
3 (Bottom)	3-1/2 in. 8-Bolt	Type 8
4 (End)	6 in. NH	Type 13

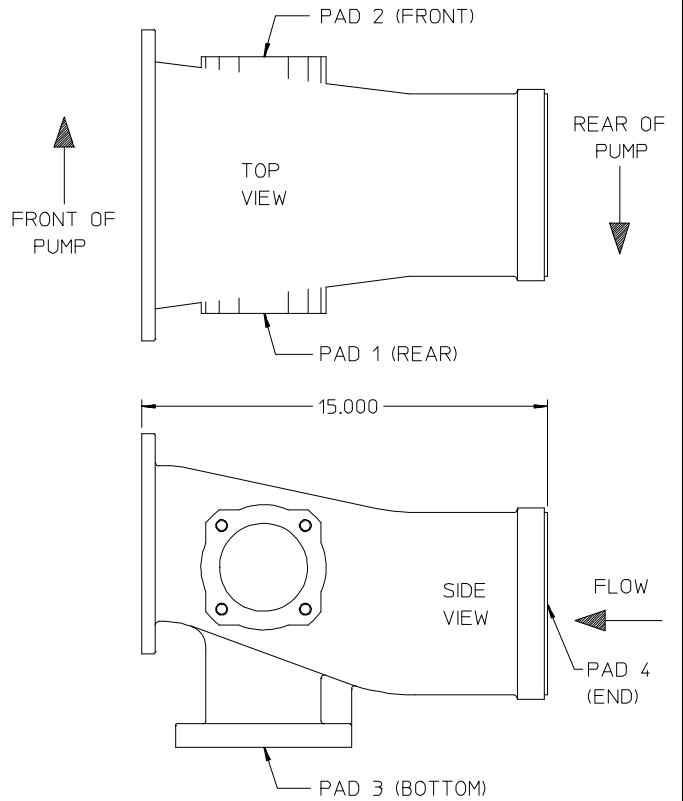

Right Side Mounting

Intake Fitting: 81916

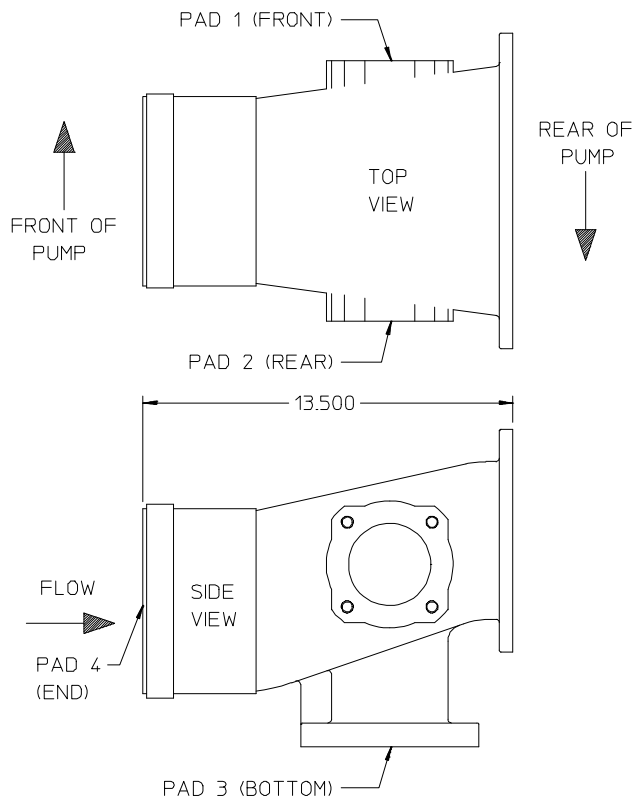

Pad	Machined	Install Auxiliary Fittings
1 (Front)	2-1/2 in. 4-Bolt	Type 1
2 (Rear)	2-1/2 in. 4-Bolt	Type 1
3 (Bottom)	3-1/2 in. 8-Bolt	Type 8
4 (End)	6 in. NH	Type 13

Left Side Mounting

Pad	Machined	Install Auxiliary Fittings
1 (Rear)	2-1/2 in. 4-Bolt	Type 1
2 (Front)	2-1/2 in. 4-Bolt	Type 1
3 (Bottom)	3-1/2 in. 8-Bolt	Type 8
4 (End)	6 in. NH	Type 13

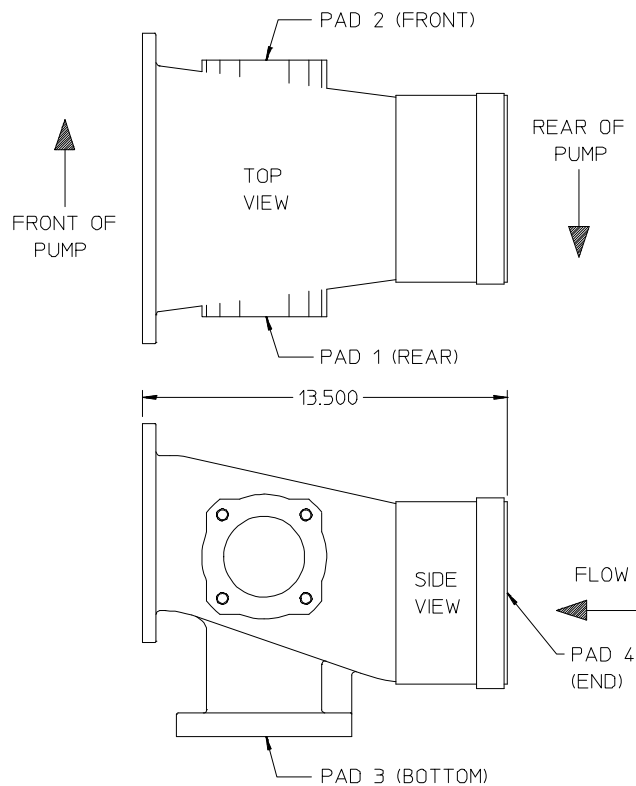

Right Side Mounting

Intake Fitting: 82011/82011-BZ

Pad	Machined	Install Auxiliary Fittings
1 (Front)	2-1/2 in. 4-Bolt	Type 1
2 (Rear)	2-1/2 in. 4-Bolt	Type 1
3 (Bottom)	3-1/2 in. 8-Bolt	Type 8
4 (End)	6 in. ANSI	Type 12

Left Side Mounting

Pad	Machined	Install Auxiliary Fittings
1 (Rear)	2-1/2 in. 4-Bolt	Type 1
2 (Front)	2-1/2 in. 4-Bolt	Type 1
3 (Bottom)	3-1/2 in. 8-Bolt	Type 8
4 (End)	6 in. ANSI	Type 12

Right Side Mounting

Intake Fitting: 82163/82163-BZ

Left Side Mounting

The diagram shows the left side mounting configuration. The top view is labeled 'TOP VIEW' and shows the 'FRONT OF PUMP' on the left and 'REAR OF PUMP' on the right. Pads are labeled: PAD 1 (UPPER FRONT), PAD 3 (LOWER FRONT), PAD 2 (UPPER REAR), and PAD 4 (LOWER REAR). The side view is labeled 'SIDE VIEW' and shows 'FLOW' entering from the left and 'PAD 5 (END)' at the far left. A dimension of 15.000 is shown between the front and rear of the fitting. PAD 6 (RELIEF VALVE) is shown at the bottom right.

Pad	Machined	Install Auxiliary Fittings
1 (Upper Front)	2-1/2 in. 4-Bolt	Type 1
2 (Upper Rear)	2-1/2 in. 4-Bolt	Type 1
3 (Lower Front)	2-1/2 in. 4-Bolt	Type 1
4 (Lower Rear)	2-1/2 in. 4-Bolt	Type 1
5 (End)	6 in. NH	Type 13
6 (R.V.)	4 in. R.V.	Type 15

Right Side Mounting

The diagram shows the right side mounting configuration. The top view is labeled 'TOP VIEW' and shows the 'FRONT OF PUMP' on the left and 'REAR OF PUMP' on the right. Pads are labeled: PAD 4 (LOWER FRONT), PAD 2 (UPPER FRONT), PAD 3 (LOWER REAR), and PAD 1 (UPPER REAR). The side view is labeled 'SIDE VIEW' and shows 'FLOW' entering from the right and 'PAD 5 (END)' at the far right. A dimension of 15.000 is shown between the front and rear of the fitting. PAD 6 (RELIEF VALVE) is shown at the bottom left.

Pad	Machined	Install Auxiliary Fittings
1 (Upper Rear)	2-1/2 in. 4-Bolt	Type 1
2 (Upper Front)	2-1/2 in. 4-Bolt	Type 1
3 (Lower Rear)	2-1/2 in. 4-Bolt	Type 1
4 (Lower Front)	2-1/2 in. 4-Bolt	Type 1
5 (End)	6 in. NH	Type 13
6 (R.V.)	4 in. R.V.	Type 15

Intake Fitting: 82165/82165-BZ

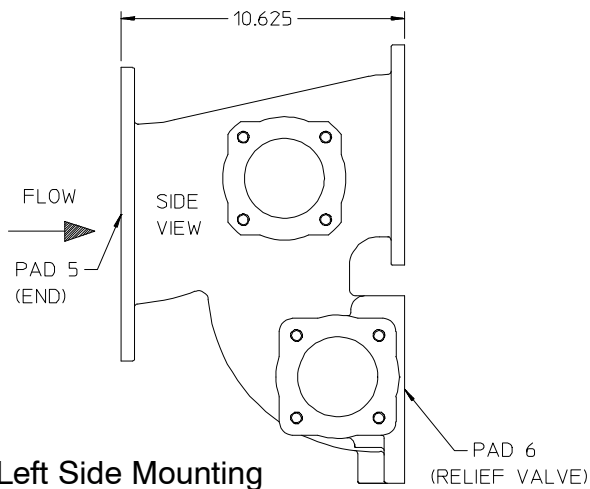
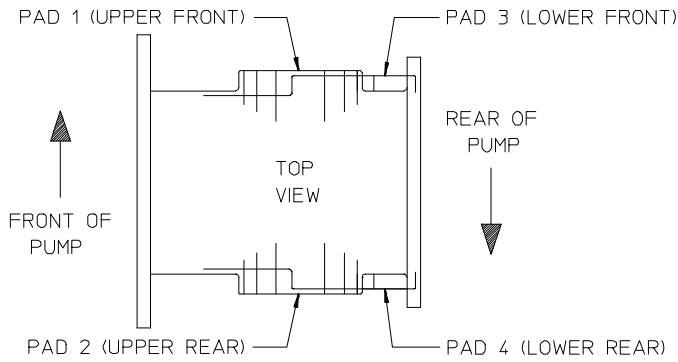

Left Side Mounting

Pad	Machined	Install Auxiliary Fittings
1 (Upper Front)	2-1/2 in. 4-Bolt	Type 1
2 (Upper Rear)	2-1/2 in. 4-Bolt	Type 1
3 (Lower Front)	2-1/2 in. 4-Bolt	Type 1
4 (Lower Rear)	2-1/2 in. 4-Bolt	Type 1
5 (End)	6 in. ANSI	Type 12
6 (R.V.)	4 in. R.V.	Type 15

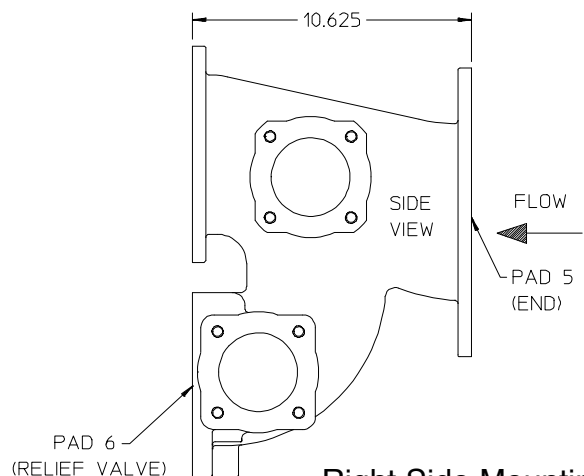
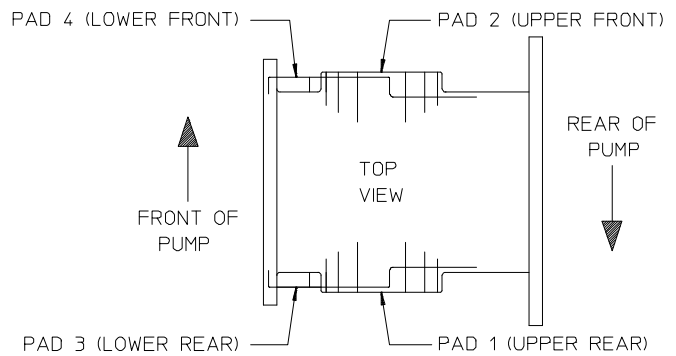

Right Side Mounting

Pad	Machined	Install Auxiliary Fittings
1 (Upper Rear)	2-1/2 in. 4-Bolt	Type 1
2 (Upper Front)	2-1/2 in. 4-Bolt	Type 1
3 (Lower Rear)	2-1/2 in. 4-Bolt	Type 1
4 (Lower Front)	2-1/2 in. 4-Bolt	Type 1
5 (End)	6 in. ANSI	Type 12
6 (R.V.)	4 in. R.V.	Type 15

Intake Fitting: 82166/82166-BZ

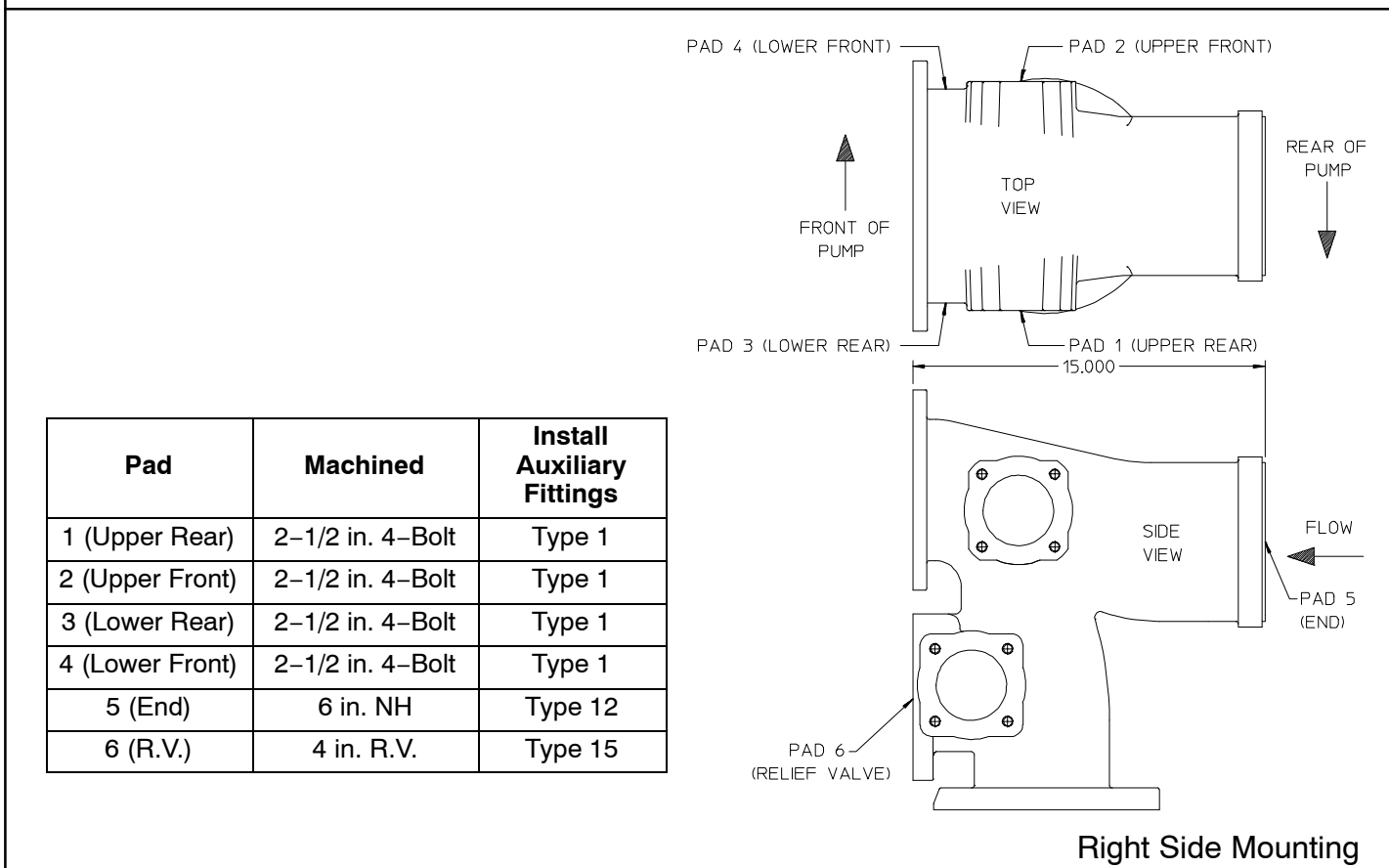
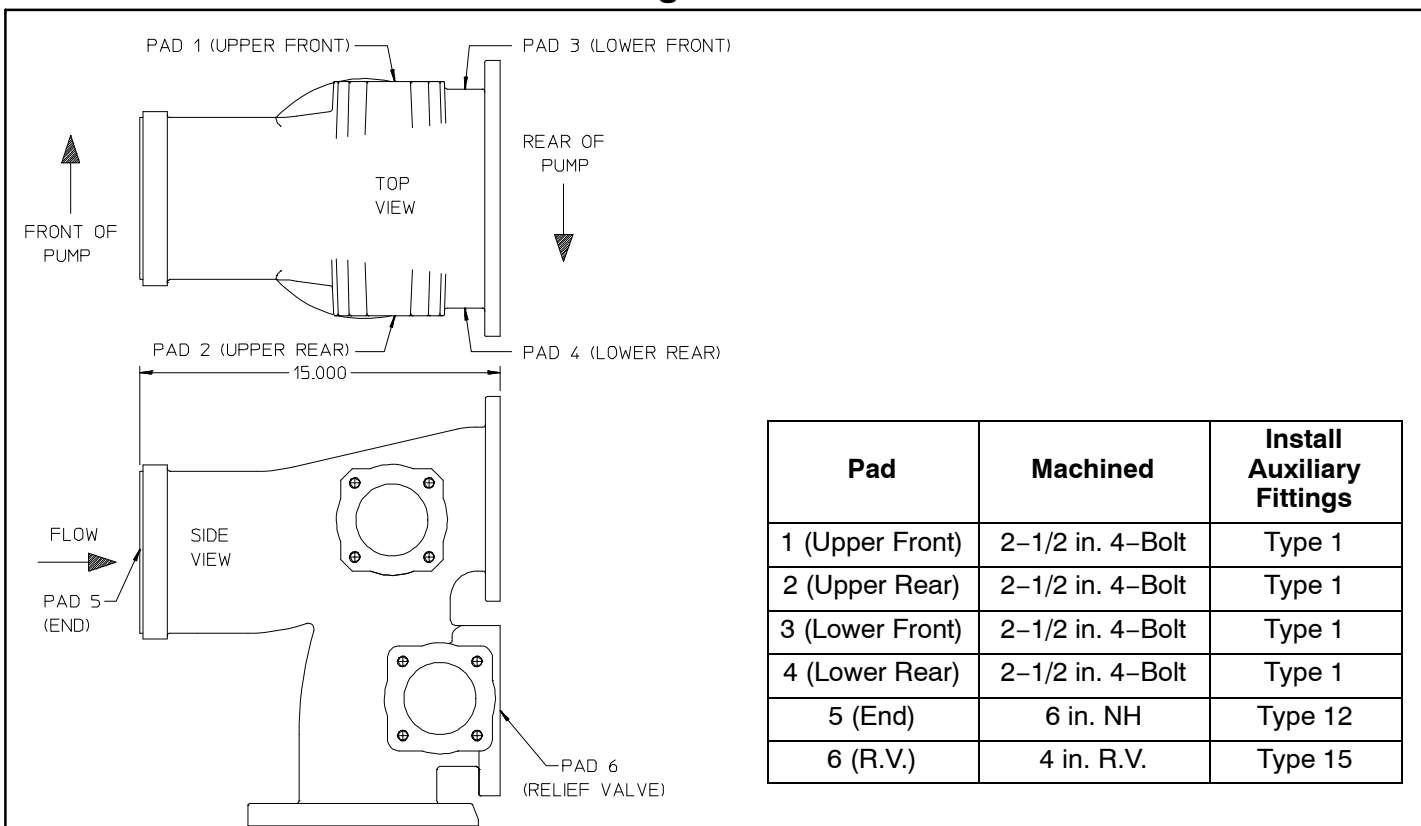

Intake Fitting: 82173/82173-BZ

Left Side Mounting

Diagram showing the left side mounting configuration. The top view shows the pump's front and rear, with pads 1 (Upper Front), 2 (Upper Rear), 3 (Lower Front), and 4 (Lower Rear) positioned around the intake. The side view shows the flow direction from left to right, with pad 5 (End) at the front and pad 6 (Relief Valve) at the bottom. A dimension of 13.500 is indicated between the front and rear of the pump.

Pad	Machined	Install Auxiliary Fittings
1 (Upper Front)	2-1/2 in. 4-Bolt	Type 1
2 (Upper Rear)	2-1/2 in. 4-Bolt	Type 1
3 (Lower Front)	2-1/2 in. 4-Bolt	Type 1
4 (Lower Rear)	2-1/2 in. 4-Bolt	Type 1
5 (End)	6 in. NH	Type 13
6 (R.V.)	4 in. R.V.	Type 15

Right Side Mounting

Diagram showing the right side mounting configuration. The top view shows the pump's front and rear, with pads 1 (Upper Rear), 2 (Upper Front), 3 (Lower Rear), and 4 (Lower Front) positioned around the intake. The side view shows the flow direction from right to left, with pad 5 (End) at the front and pad 6 (Relief Valve) at the bottom. A dimension of 13.500 is indicated between the front and rear of the pump.

Pad	Machined	Install Auxiliary Fittings
1 (Upper Rear)	2-1/2 in. 4-Bolt	Type 1
2 (Upper Front)	2-1/2 in. 4-Bolt	Type 1
3 (Lower Rear)	2-1/2 in. 4-Bolt	Type 1
4 (Lower Front)	2-1/2 in. 4-Bolt	Type 1
5 (End)	6 in. NH	Type 13
6 (R.V.)	4 in. R.V.	Type 15

Intake Fitting: 82174

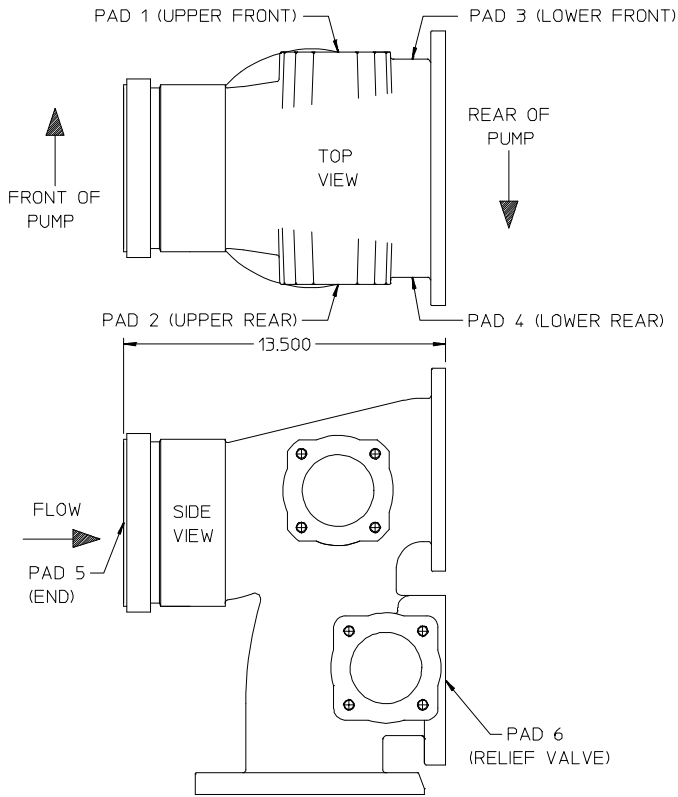

Pad	Machined	Install Auxiliary Fittings
1 (Upper Front)	2-1/2 in. 4-Bolt	Type 1
2 (Upper Rear)	2-1/2 in. 4-Bolt	Type 1
3 (Lower Front)	2-1/2 in. 4-Bolt	Type 1
4 (Lower Rear)	2-1/2 in. 4-Bolt	Type 1
5 (End)	6 in. NH	Type 12
6 (R.V.)	4 in. R.V.	Type 15

Left Side Mounting

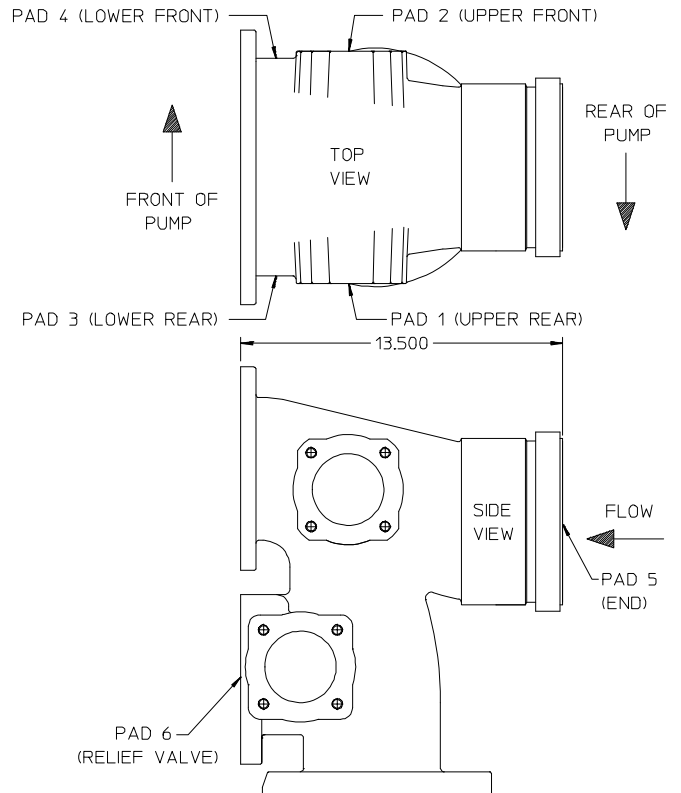

Pad	Machined	Install Auxiliary Fittings
1 (Upper Rear)	2-1/2 in. 4-Bolt	Type 1
2 (Upper Front)	2-1/2 in. 4-Bolt	Type 1
3 (Lower Rear)	2-1/2 in. 4-Bolt	Type 1
4 (Lower Front)	2-1/2 in. 4-Bolt	Type 1
5 (End)	6 in. NH	Type 12
6 (R.V.)	4 in. R.V.	Type 15

Right Side Mounting

Intake Fitting: 82188

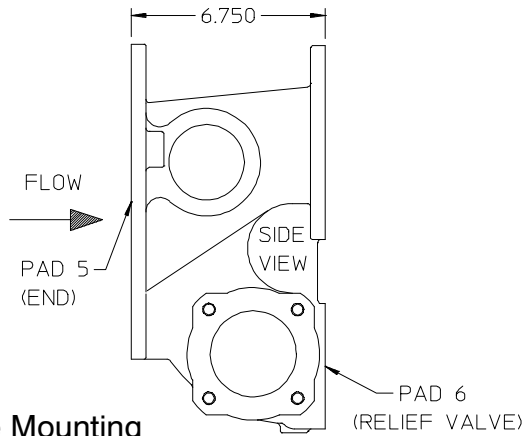
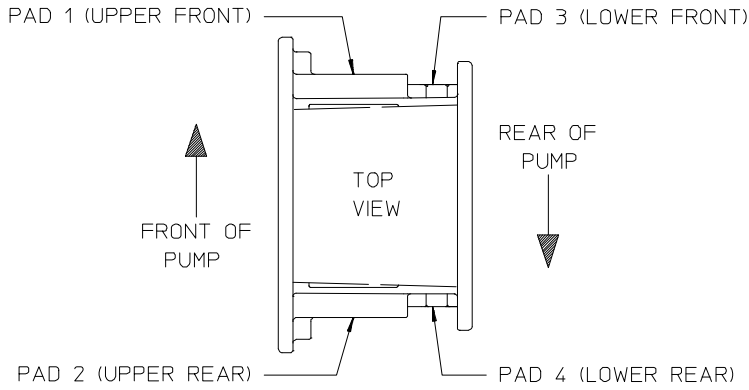

Pad	Machined	Install Auxiliary Fittings
1 (Upper Front)	2-1/2 NPT	Type 2
2 (Upper Rear)	2-1/2 NPT	Type 2
3 (Lower Front)	2-1/2 in. 4-Bolt	Type 1
4 (Lower Rear)	2-1/2 in. 4-Bolt	Type 1
5 (End)	6 in. ANSI	Type 17
6 (R.V.)	3 in. R.V.	Type 14

Left Side Mounting

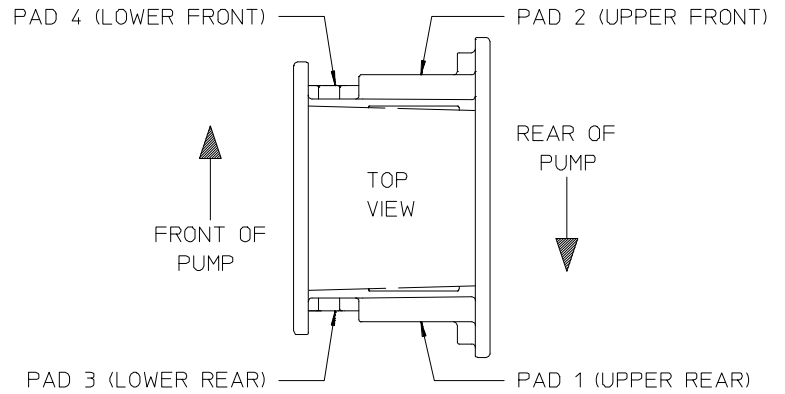

Pad	Machined	Install Auxiliary Fittings
1 (Upper Rear)	2-1/2 NPT	Type 2
2 (Upper Front)	2-1/2 NPT	Type 2
3 (Lower Rear)	2-1/2 in. 4-Bolt	Type 1
4 (Lower Front)	2-1/2 in. 4-Bolt	Type 1
5 (End)	6 in. ANSI	Type 17
6 (R.V.)	3 in. R.V.	Type 14

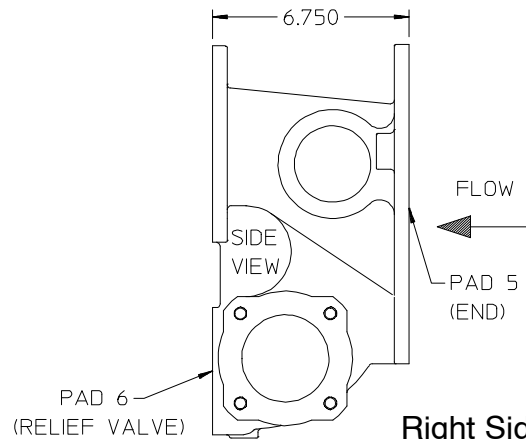

Right Side Mounting

Intake Fitting: 82199

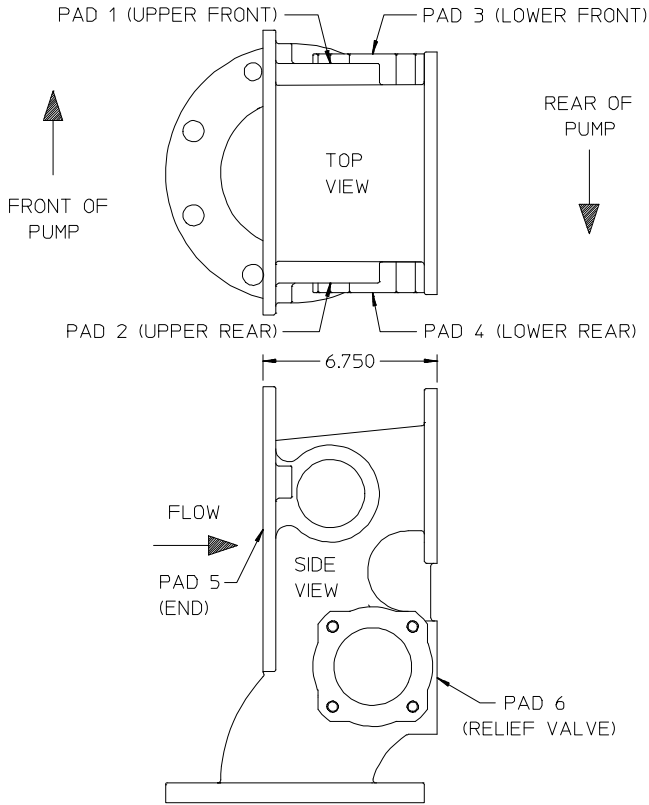

Pad	Machined	Install Auxiliary Fittings
1 (Upper Front)	2-1/2 NPT	Type 2
2 (Upper Rear)	2-1/2 NPT	Type 2
3 (Lower Front)	2-1/2 in. 4-Bolt	Type 1
4 (Lower Rear)	2-1/2 in. 4-Bolt	Type 1
5 (End)	6 in. ANSI	Type 17
6 (R.V.)	3 in. R.V.	Type 14

Left Side Mounting

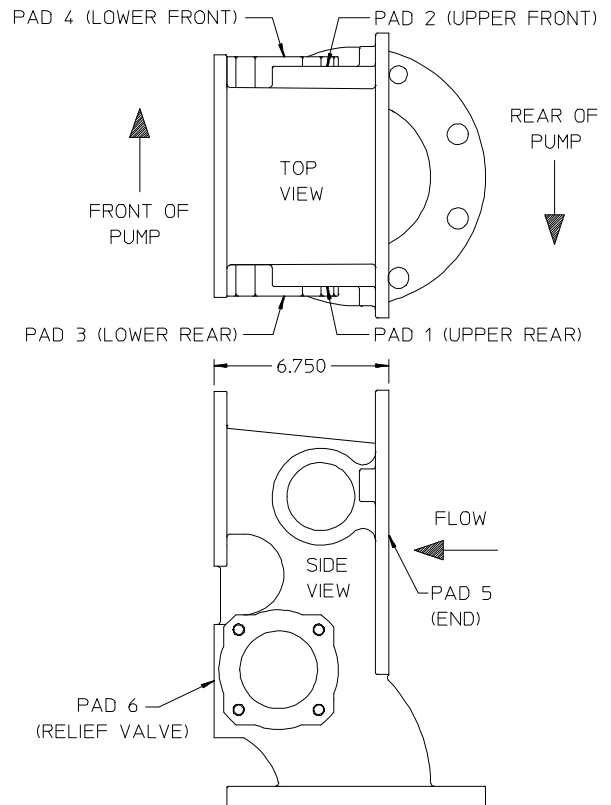

Pad	Machined	Install Auxiliary Fittings
1 (Upper Rear)	2-1/2 NPT	Type 2
2 (Upper Front)	2-1/2 NPT	Type 2
3 (Lower Rear)	2-1/2 in. 4-Bolt	Type 1
4 (Lower Front)	2-1/2 in. 4-Bolt	Type 1
5 (End)	6 in. ANSI	Type 17
6 (R.V.)	3 in. R.V.	Type 14

Right Side Mounting

Intake Fitting: 82289

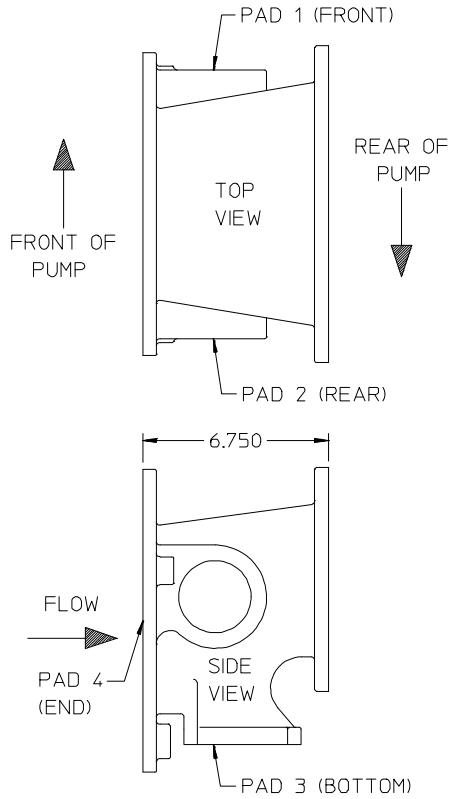

Pad	Machined	Install Auxiliary Fittings
1 (Front)	2-1/2 NPT	Type 2
2 (Rear)	2-1/2 NPT	Type 2
3 (Bottom)	2-1/2 in. 4-Bolt	Type 1
4 (End)	6 in. ANSI	Type 17

Left Side Mounting

Pad	Machined	Install Auxiliary Fittings
1 (Rear)	2-1/2 NPT	Type 2
2 (Front)	2-1/2 NPT	Type 2
3 (Bottom)	2-1/2 in. 4-Bolt	Type 1
4 (End)	6 in. ANSI	Type 17

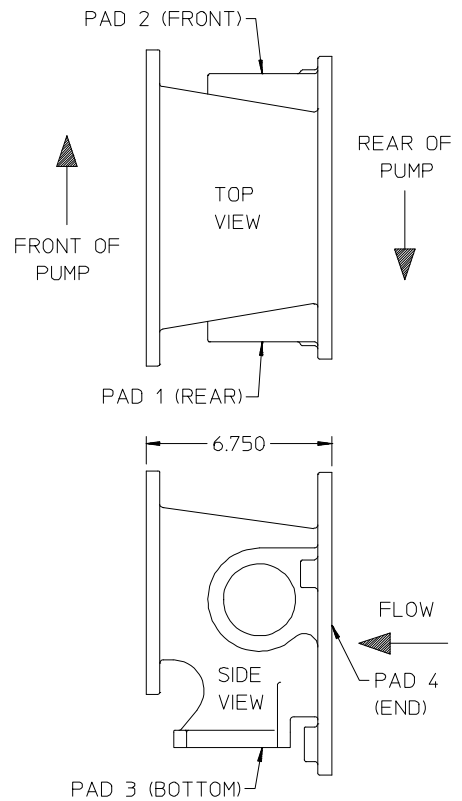

Right Side Mounting

Intake Fitting: 82301

Pad	Machined	Install Auxiliary Fittings
1 (Upper Front)	2-1/2 NPT	Type 2
2 (Upper Rear)	2-1/2 NPT	Type 2
3 (Lower Front)	2-1/2 in. 4-Bolt	Type 1
4 (Lower Rear)	2-1/2 in. 4-Bolt	Type 1
5 (End)	6 in. ANSI	Type 17
6 (R.V.)	4 in. R.V.	Type 15

Left Side Mounting

Pad	Machined	Install Auxiliary Fittings
1 (Upper Rear)	2-1/2 NPT	Type 2
2 (Upper Front)	2-1/2 NPT	Type 2
3 (Lower Rear)	2-1/2 in. 4-Bolt	Type 1
4 (Lower Front)	2-1/2 in. 4-Bolt	Type 1
5 (End)	6 in. ANSI	Type 17
6 (R.V.)	4 in. R.V.	Type 15

Right Side Mounting

Intake Fitting: 82302

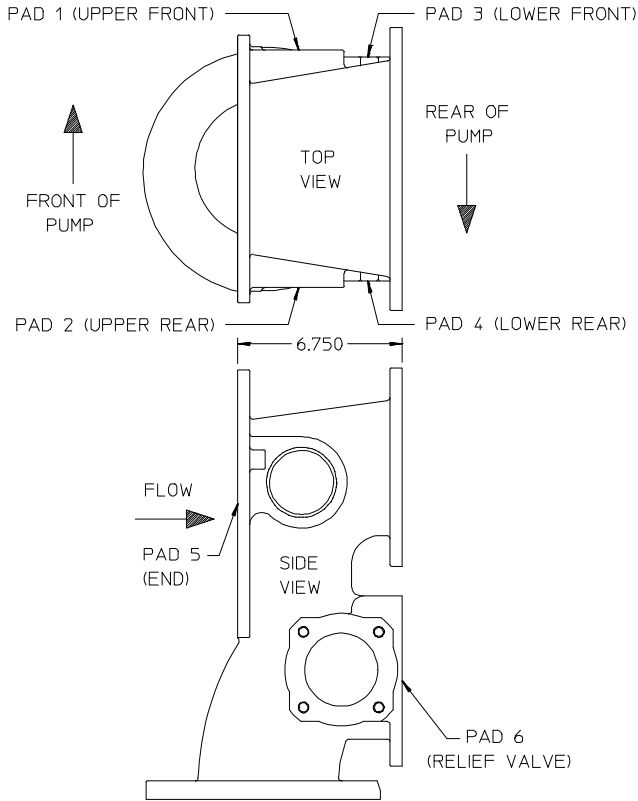

Pad	Machined	Install Auxiliary Fittings
1 (Upper Front)	2-1/2 NPT	Type 2
2 (Upper Rear)	2-1/2 NPT	Type 2
3 (Lower Front)	2-1/2 in. 4-Bolt	Type 1
4 (Lower Rear)	2-1/2 in. 4-Bolt	Type 1
5 (End)	6 in. ANSI	Type 17
6 (R.V.)	4 in. R.V.	Type 15

Left Side Mounting

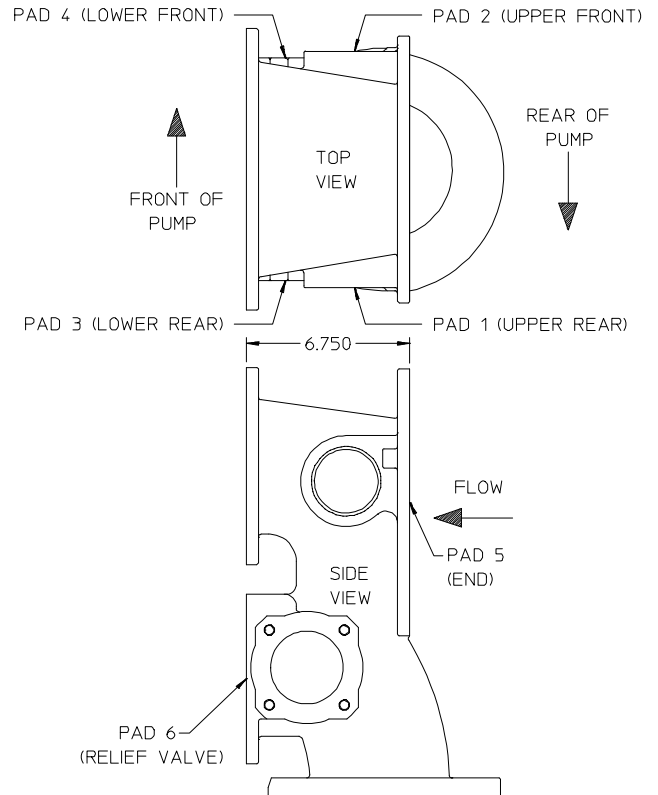

Pad	Machined	Install Auxiliary Fittings
1 (Upper Rear)	2-1/2 NPT	Type 2
2 (Upper Front)	2-1/2 NPT	Type 2
3 (Lower Rear)	2-1/2 in. 4-Bolt	Type 1
4 (Lower Front)	2-1/2 in. 4-Bolt	Type 1
5 (End)	6 in. ANSI	Type 17
6 (R.V.)	4 in. R.V.	Type 15

Right Side Mounting

Intake Fitting: 82767

Pad	Machined	Install Auxiliary Fittings
1 (Front)	2-1/2 in. 4-Bolt	Type 1
2 (Rear)	2-1/2 in. 4-Bolt	Type 1
3 (Bottom)	3-1/2 in. 8-Bolt	Type 8
4 (End)	5 in. NH	Type 23

Left Side Mounting

Pad	Machined	Install Auxiliary Fittings
1 (Rear)	2-1/2 in. 4-Bolt	Type 1
2 (Front)	2-1/2 in. 4-Bolt	Type 1
3 (Bottom)	3-1/2 in. 8-Bolt	Type 8
4 (End)	5 in. NH	Type 23

Right Side Mounting

Intake Fitting: 82768

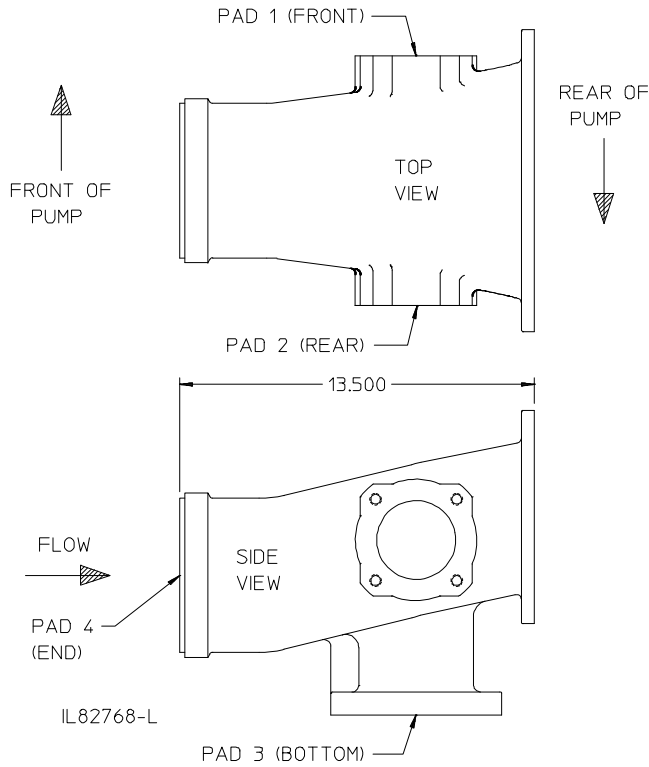

Pad	Machined	Install Auxiliary Fittings
1 (Front)	2-1/2 in. 4-Bolt	Type 1
2 (Rear)	2-1/2 in. 4-Bolt	Type 1
3 (Bottom)	3-1/2 in. 8-Bolt	Type 8
4 (End)	5 in. NH	Type 23

Left Side Mounting

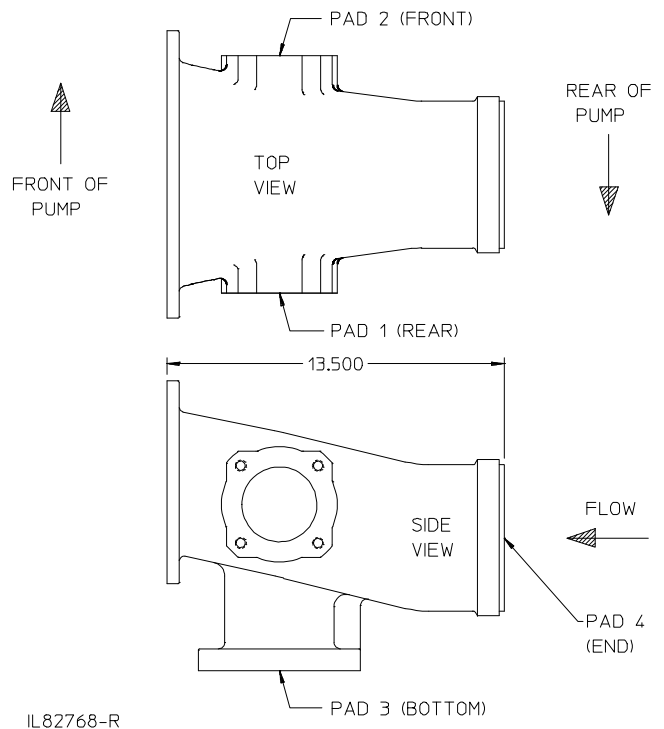

Pad	Machined	Install Auxiliary Fittings
1 (Rear)	2-1/2 in. 4-Bolt	Type 1
2 (Front)	2-1/2 in. 4-Bolt	Type 1
3 (Bottom)	3-1/2 in. 8-Bolt	Type 8
4 (End)	5 in. NH	Type 23

Right Side Mounting

Intake Fitting: 82952

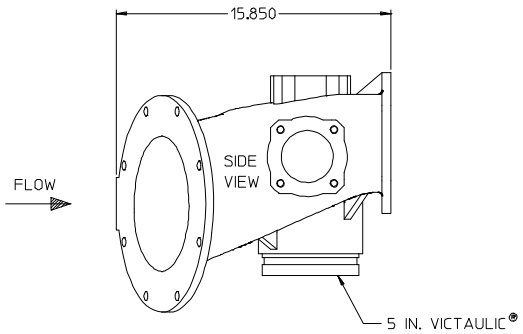
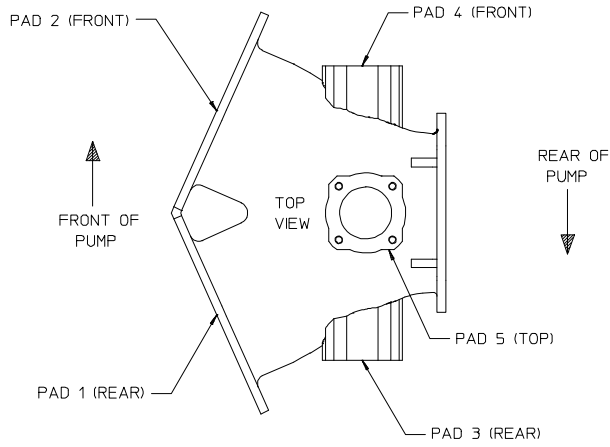

Pad	Machined	Install Auxiliary Fittings
1 (Rear)	8 in. ANSI	Type 30
2 (Front)		
3 (Rear)	4-Bolt	Type 1
4 (Front)		
5 (Top)		

Left Side Mounting

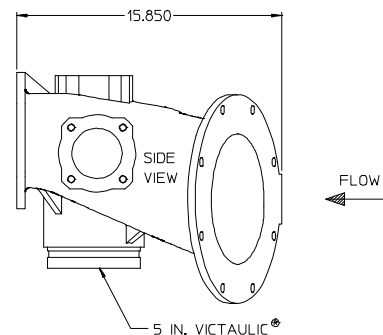
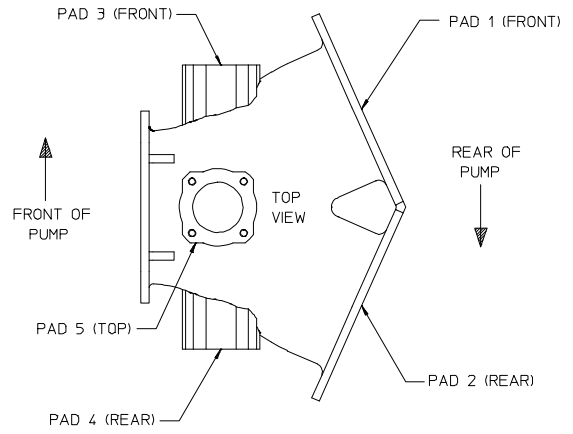

Pad	Machined	Install Auxiliary Fittings
1 (Front)	8 in. ANSI	Type 30
2 (Rear)		
3 (Front)	4-Bolt	Type 1
4 (Rear)		
5 (Top)		

Right Side Mounting

Intake Fitting: 83041

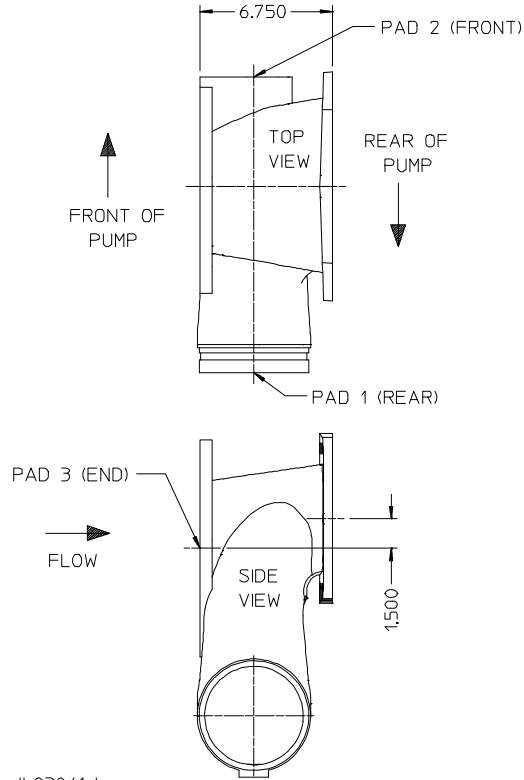

IL83041-L

Left Side Mounting

Pad	Machined	Install Auxiliary Fittings
1 (Front)	2-1/2 in. 4-Bolt	Type 2
2 (Rear)	5 in. Victaulic	-
3 (End)	6 in. ANSI	Type 17

Pad	Machined	Install Auxiliary Fittings
1 (Rear)	2-1/2 in. 4-Bolt	Type 2
2 (Front)	5 in. Victaulic	-
3 (End)	6 in. ANSI	Type 17

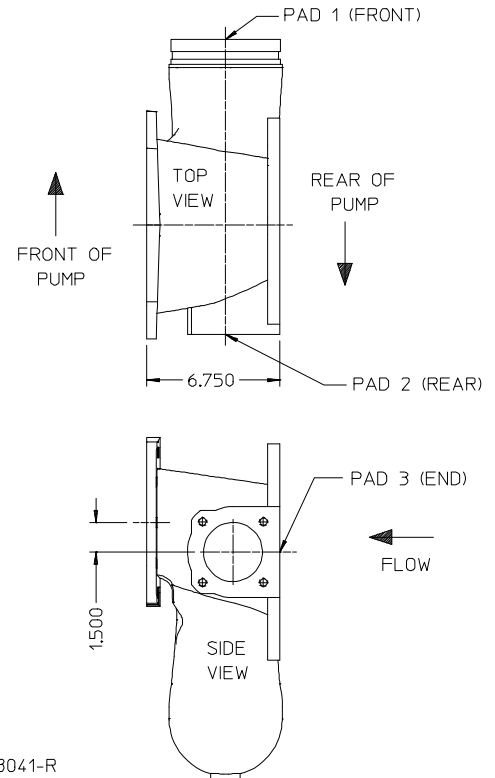

IL83041-R

Right Side Mounting