

# KC Transmissions

# Overhaul Instructions

Form No.	Section	Issue Date	Rev. Date
F-1031	4310	02/08/96	12/30/15

## Table of Contents

<b>Disassembling</b> .....	1
Driven Shaft .....	2
Removing Drive Shaft .....	3
Rotating Union .....	4
Drive Shaft .....	5
<b>Reassembly</b> .....	6
Inspection .....	6
Installing Ball Bearings .....	6
Installing Oil Seals .....	6
Installing Gaskets .....	6
Final Assembly .....	6

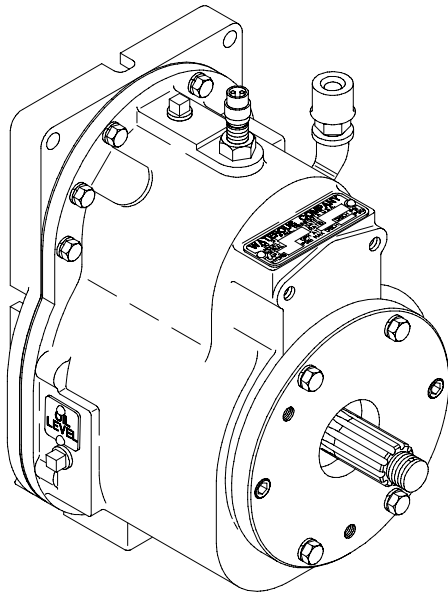

**WATEROUS**

*Fire Pumps – Since 1886*



## Disassembling the Transmission Cover

1. Disconnect hose to hydraulic pump and remove connector.
2. Disconnect propeller shaft from drive shaft.
3. Disconnect tachometer pickup cable, if used, and remove magnetic pickup.
4. Drain lubricant from gear case.
5. Remove cap screws and lock washers attaching gear case to bearing housing.
6. Reinstall two cap screws in tapped holes in gear case and bearing housing, and turn in evenly to separate case from housing.

**NOTE: Jacking screw hole in gear case is on right hand edge, slightly below impeller shaft (viewed from drive shaft end). In bearing housing, tapped hole is on opposite side, about in line with drive shaft.**

7. Pull gear case straight back from bearing housing. Assembled drive shaft may come part way out, but will probably stay meshed with driven gear.
8. Remove oil seal from gear case.

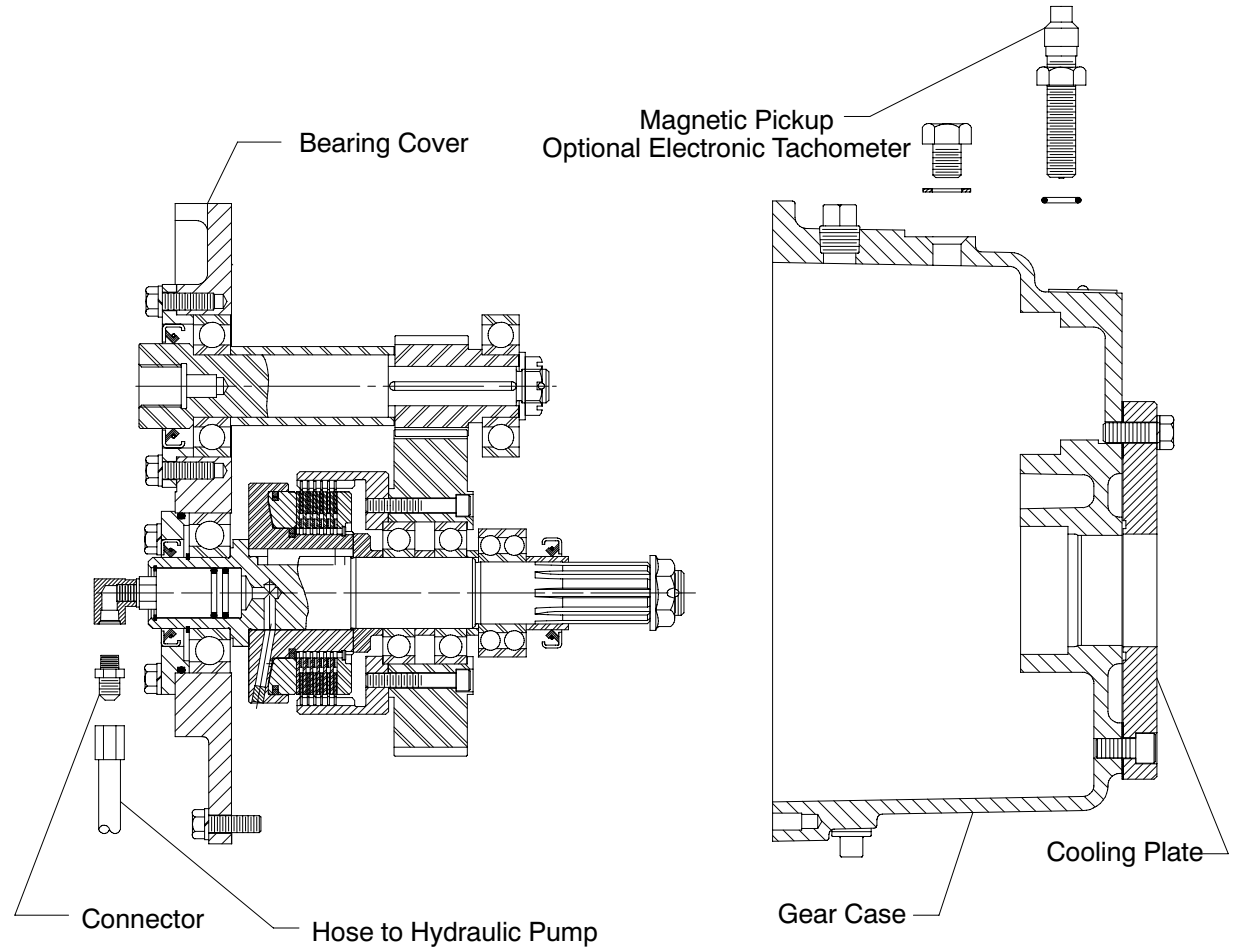

IL1066

## Disassembling the Driven Shaft

1. Straighten bent tab of bearing lock washer and unscrew lock nut from impeller shaft. Remove lock washer, outer bearing and outer spacer.
2. With a suitable puller, remove driven gear and key, and pull off inner spacer.
3. Remove bolts attaching bearing housing to pump body and remove inner bearing from bearing housing.

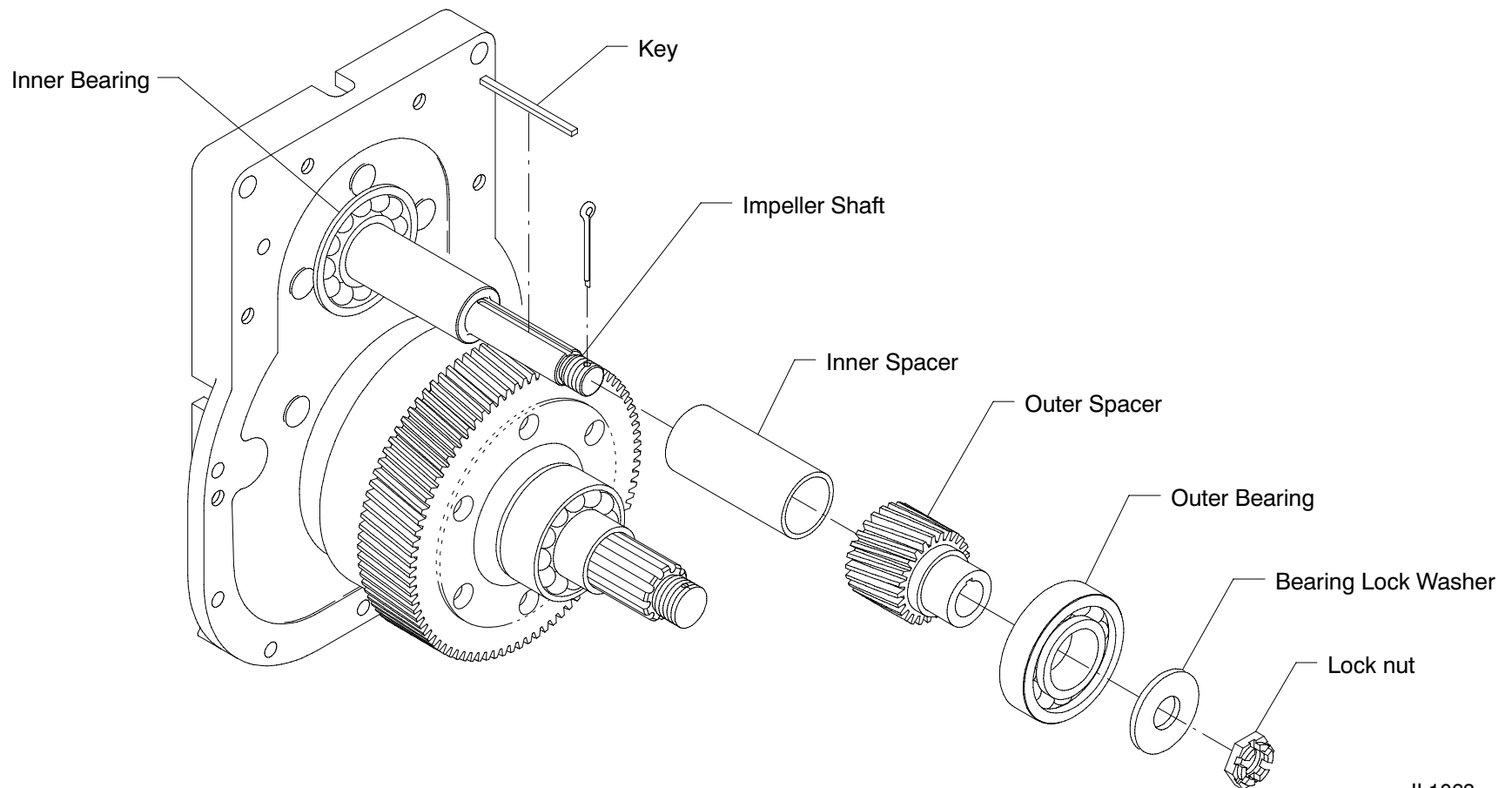

IL1063

## Removing the Drive Shaft

1. Remove assembled drive shaft from bearing housing.
2. Remove screws attaching oil seal housing to bearing housing.
3. Remove oil seal housing, O-ring and oil seal.

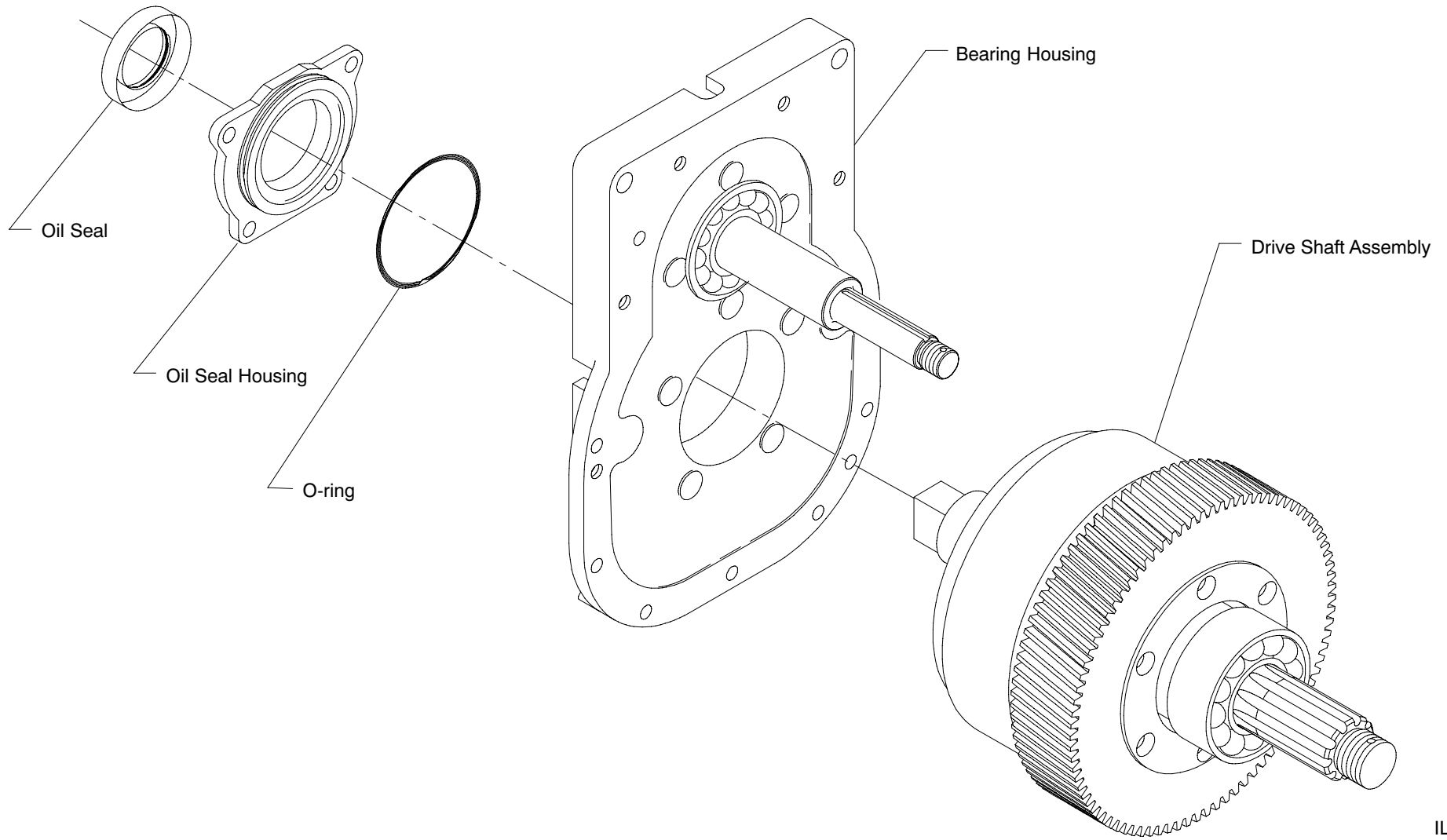

## Disassembling the Rotating Union

1. Remove the hydraulic inlet elbow from the rotating union.
2. Remove retaining ring from the inside of the drive shaft and pull the rotating union out.
3. Remove retaining ring and bearing.

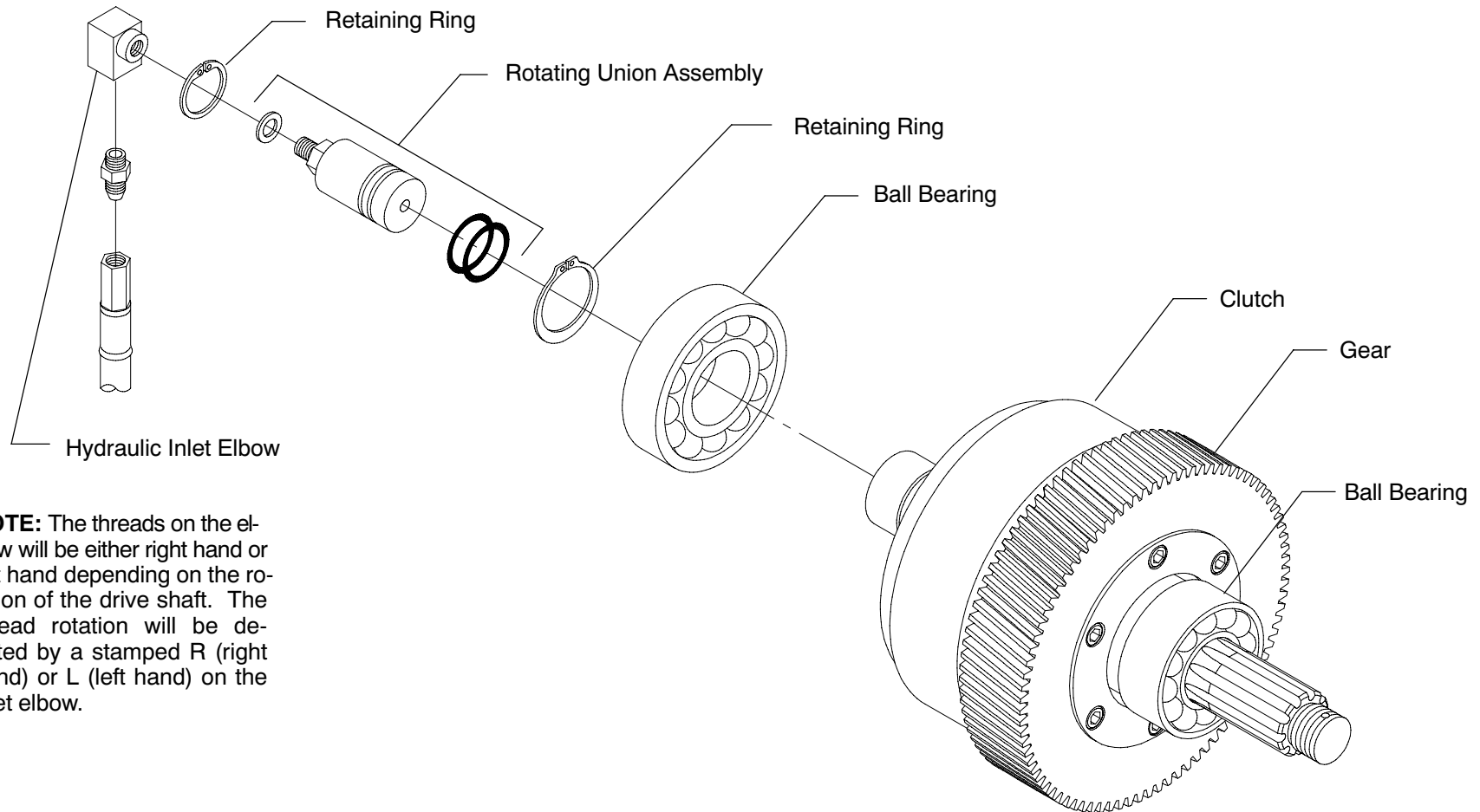

**NOTE:** The threads on the elbow will be either right hand or left hand depending on the rotation of the drive shaft. The thread rotation will be denoted by a stamped R (right hand) or L (left hand) on the inlet elbow.

## Disassembling the Drive Shaft

1. Press the oil seal sleeve, ball bearings, spacers, drive gear and drive clutch cup from drive shaft.

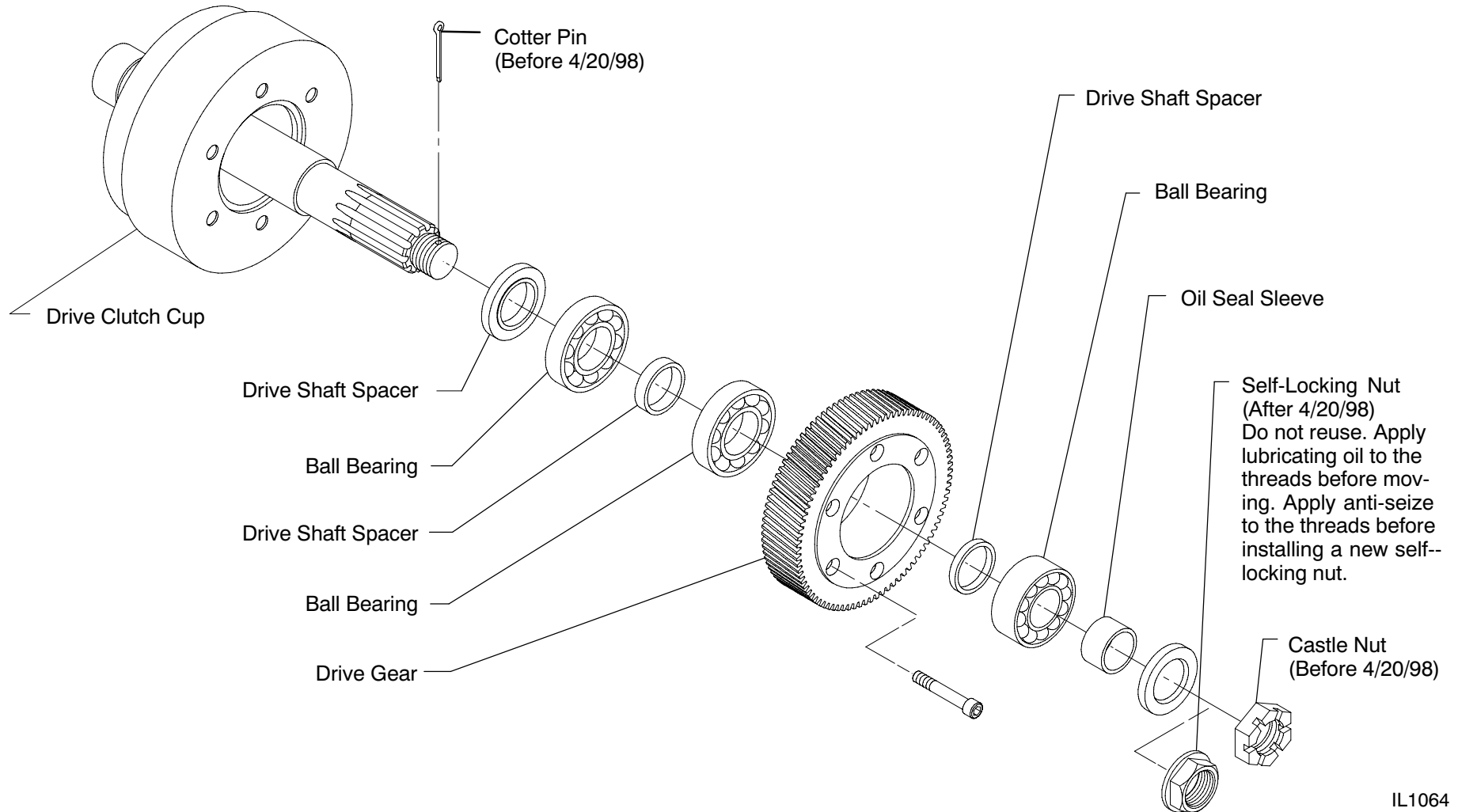

IL1064

# Reassembly

## *Inspection*

Examine all components for signs of excessive wear or other defects and replace if necessary. Replace all bearings, seals, gaskets, self-locking nuts and any defective parts. Reassembly is essentially the opposite of removal and disassembly. Be sure to observe the following points.

### ***Installing Ball Bearings***

Keep bearings covered until they are to be installed. Before pressing a bearing on a shaft, coat its bore with grease. Always apply force to the inner race of a ball bearing when pressing it on a shaft, never to the outer race. Press on evenly with a piece of pipe or tube which will just clear the shaft. Be sure the shaft is clean before installing the bearing.

### ***Installing Oil Seals***

Before installing an oil seal in a housing, apply a thin coat of sealant to housing oil seal seat. (Waterous recommends Loctite Ultra Blue RTV Silicon Sealant to Permatex Super 300). Be sure that seal, shaft and housing are clean. Always install a seal with the seal lip facing in. Apply force to the outer edge of a seal and press in evenly.

### ***Installing Gaskets***

If a gasket is awkward to hold in place while assembling a component, coat one of the mating flanges with heavy grease, and press the gasket into position against the flange. The grease will hold the gasket in place during reassembly.

### ***End Yoke and Companion Flange Nuts***

Do not reuse self-locking nuts. Apply lubrication oil to the threads before removing. Apply anti-seize to the threads before installing a new self-locking nut.

## ***Final Assembly***

1. If equipped, reinstall magnetic pickup. Turn it in until the tip contacts a tooth of the driven gear. Back off 1/2 turn and tighten lock nut.
2. Connect tachometer cable to the magnetic pick up, if used.
3. Connect propeller shaft to drive shaft.
4. Fill gear case through the filler plug or breather at top of gear case with SAE 80W - 90 gear oil or equivalent. Check oil level through the square head pipe plug on side of gear case marked OIL LEVEL.