

Issued: 4/80  
Revised: 02/03/03

**W A T E R O U S**

WATEROUS COMPANY  
SOUTH ST. PAUL, MINNESOTA

## ELECTRIC TRANSFER VALVE ACTUATOR ASSEMBLY (TOP MOUNTED)

REF NO.	DESCRIPTION	REF NO.	DESCRIPTION
A3	Wire Assembly	A45	Pivot pin (Part of A109, available individually for repairs)
A4	Circuit breaker, 12V, 15 amp	A46	Universal joint
A6	Valve operating arm subassembly (includes A62)	A50	Manual override rod
A7	Pivot block bushing	A56	Flat washer, 1/2 in., zinc plated
A8	Pivot block	A57	Sector gear
A16	Panel plate (switch)	A61	Wire assembly
A17	Wiring harness	A62	Sleeve bearing (part of A6, available individually for repairs)
A18	Green indicator light (VOLUME) (includes A27)	A65	Cotter pin, SS, 1/8 x 1 in.
A19	Amber indicator light (PRESSURE) (includes A27)	A67	Roll pin, SS, 1/4 x 1-1/8 in.
A21	Three-position switch, DPDT	A70	Cotter pin, SS, 3/32 x 3/4 in.
A22	Hex nut, No. 8-32 (not furnished by Waterous after 5/15/88)	A71	Flat washer, 3/8 in., zinc plated
A23	Rd hd screw, SS, No. 8-32 x 3/8 in.(not furnished by Waterous after 5/15/88)	A73	Hex hd screw, zinc plated, 5/16-18 x 1-3/4 in.
A24	Lock washer, No. 8 (not furnished by Waterous after 5/15/88)	A76	Wire assembly
A25	Tube clamp	A77	Wire assembly
A27	Light bulb, 12 volt, No. 1891 (included with A18 & A19)	A79	Remote control bearing (Part of A81, available individually for repairs)
A31	Hex jam nut, zinc plated, 5/16-18	A81	Remote control body assembly (includes A79)
A33	Hex nut, No. 10-32 (not furnished separately by Waterous after 7/12/89, part of A4)	A82	Hex nut, 1/4-20, SS
A34	Flat brass washer, 5/16 in.	A83	Lock washer, 1/4 in.
A37	Rd hd screw No. 10-24 x 3/8 in., zinc plated	A84	Rd hd screw, SS, 1/4-20 x 3/4 in.
A40	Lock washer, No. 10 (not furnished separately by Waterous after 7/12/89, part of A4)	A87	Control shaft
		A88	Control crank, manual override
		A89	Flat washer, SS, 5/8 in.

**PLEASE NOTE**

**WHEN ORDERING PARTS PLEASE SUPPLY PUMP SERIAL NUMBER**

SPL81160

PAGE 1 OF 7

## ELECTRIC TRANSFER VALVE ACTUATOR ASSEMBLY (TOP MOUNTED)

REF NO.	DESCRIPTION	REF NO.	DESCRIPTION
A91	Actuator motor (Part of A107, available individually for repairs)	A111	Hex hd screw, 3/8-16 x 1-1/4 in., grade 5
A92	Actuator motor coupling (Part of A107, available individually for repairs)	A112	Extension shaft
A96	Switch assembly	A113	Groove pin, 5/16 x 1-1/4 in., type 3H
A97	Switch bracket	A114	Sleeve bearing (part of A109, available individually for repairs)
A98	Wire assembly (not used after 3/1/92)	A115	Actuator bracket
A100	Cup point headless set screw, 1/4-20 x 1/4 in.	A116	Panel plate (manual override)
A102	Actuator end fitting	A117	Wire assembly
A104	Spring washer	A119	Thrust race washer
A105	Cotter pin, SS, 1/8 x 1-1/2 in.	A120	Hex hd screw, zinc plated, 5/16-18 x 2 in., grade 5
A106	Switch seal	A121	Sleeve connector
A107	Actuator subassembly (includes A7, A8, A91, A100, A102, A104, A105, 119, A126 & A127)	A122	Lock washer, 5/16, zinc plated
A109	Plate subassembly (includes A45 and A114)	A123	Hex hd screw, 3/8-16 x 1-1/2 in.
A110	Wiring assembly (includes A3, A4, A17, A18, A19, A21, A61, A76, A77 & A117)	A126	Actuator gearbox (part of A107, available individually for repairs)
		A127	Actuator, less motor (part of A107, available individually for repairs)

**PLEASE NOTE**

**WHEN ORDERING PARTS PLEASE SUPPLY PUMP SERIAL NUMBER**





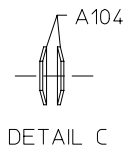

**A107 ACTUATOR ASSEMBLY**  
 INCLUDES A7, A8, A91, A100, A102, A104 & A105.  
 NOTE: IF PIVOT BLOCK (A8) IS REPLACED, FREE  
 PLAY OF SECTOR (A57) MUST BE ADJUSTED  
 AS INDICATED ON NEXT TO LAST PAGE.

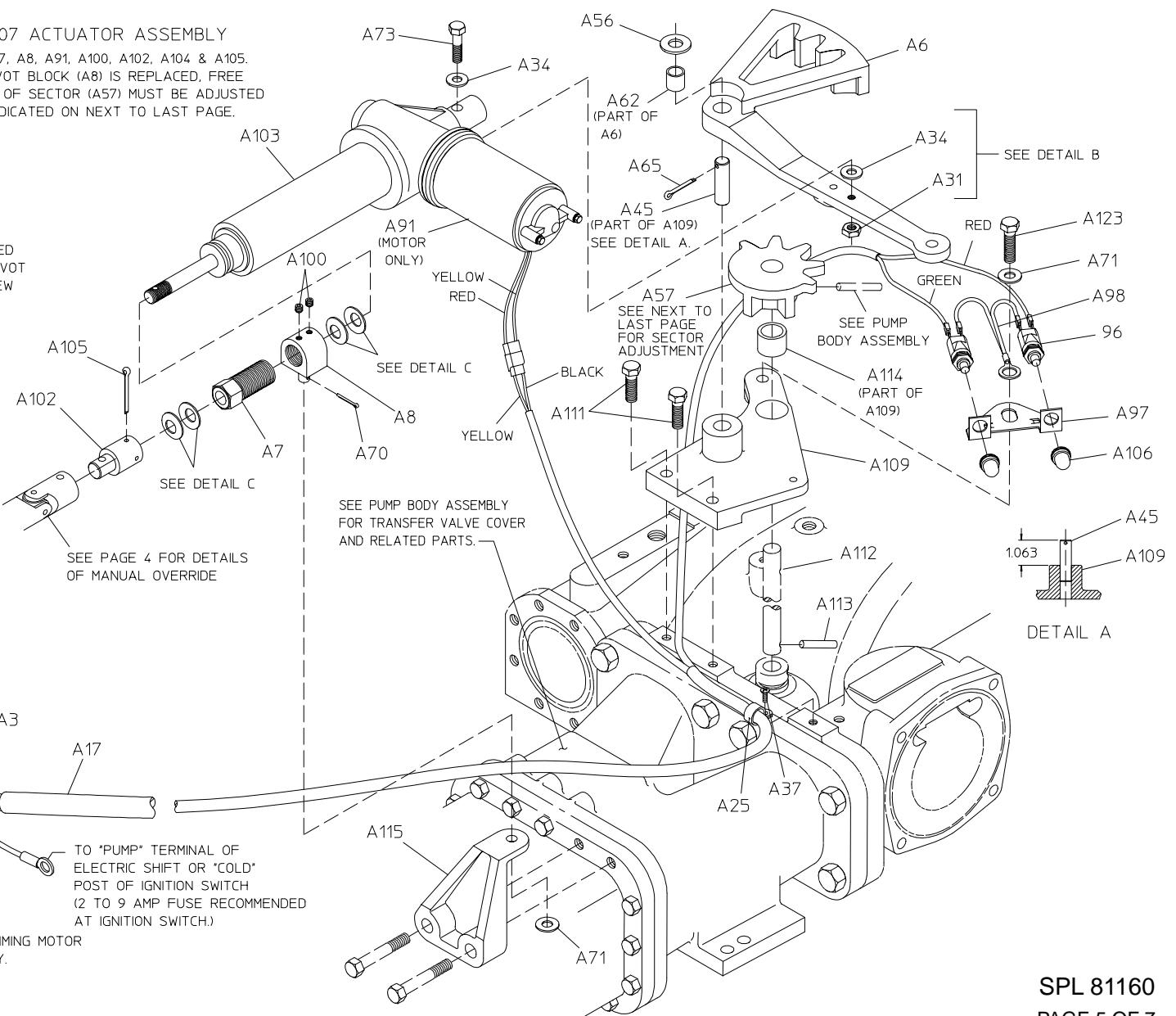
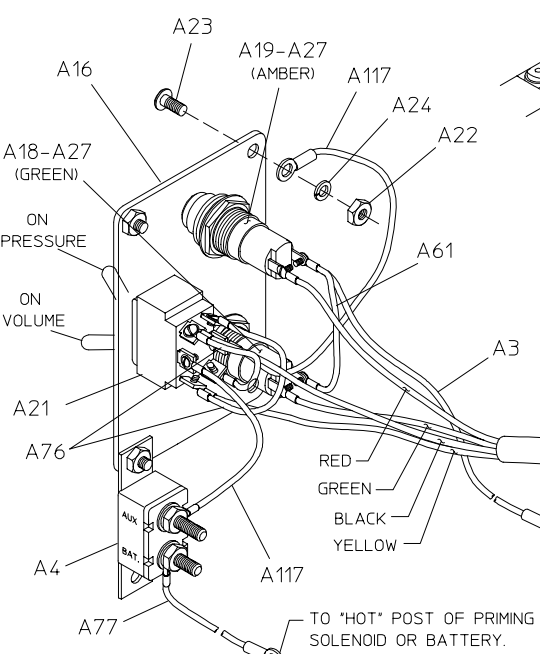
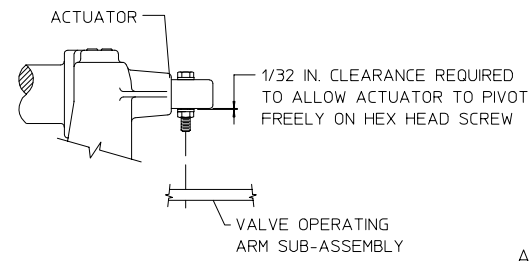

ASSEMBLY PRIOR TO 9-18-85

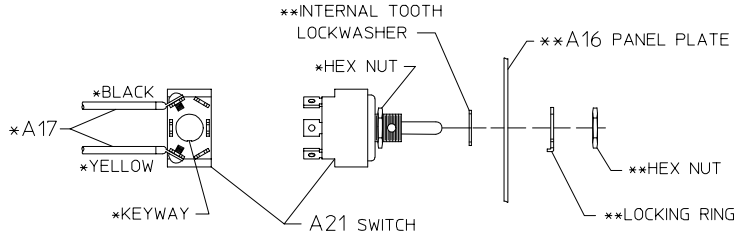
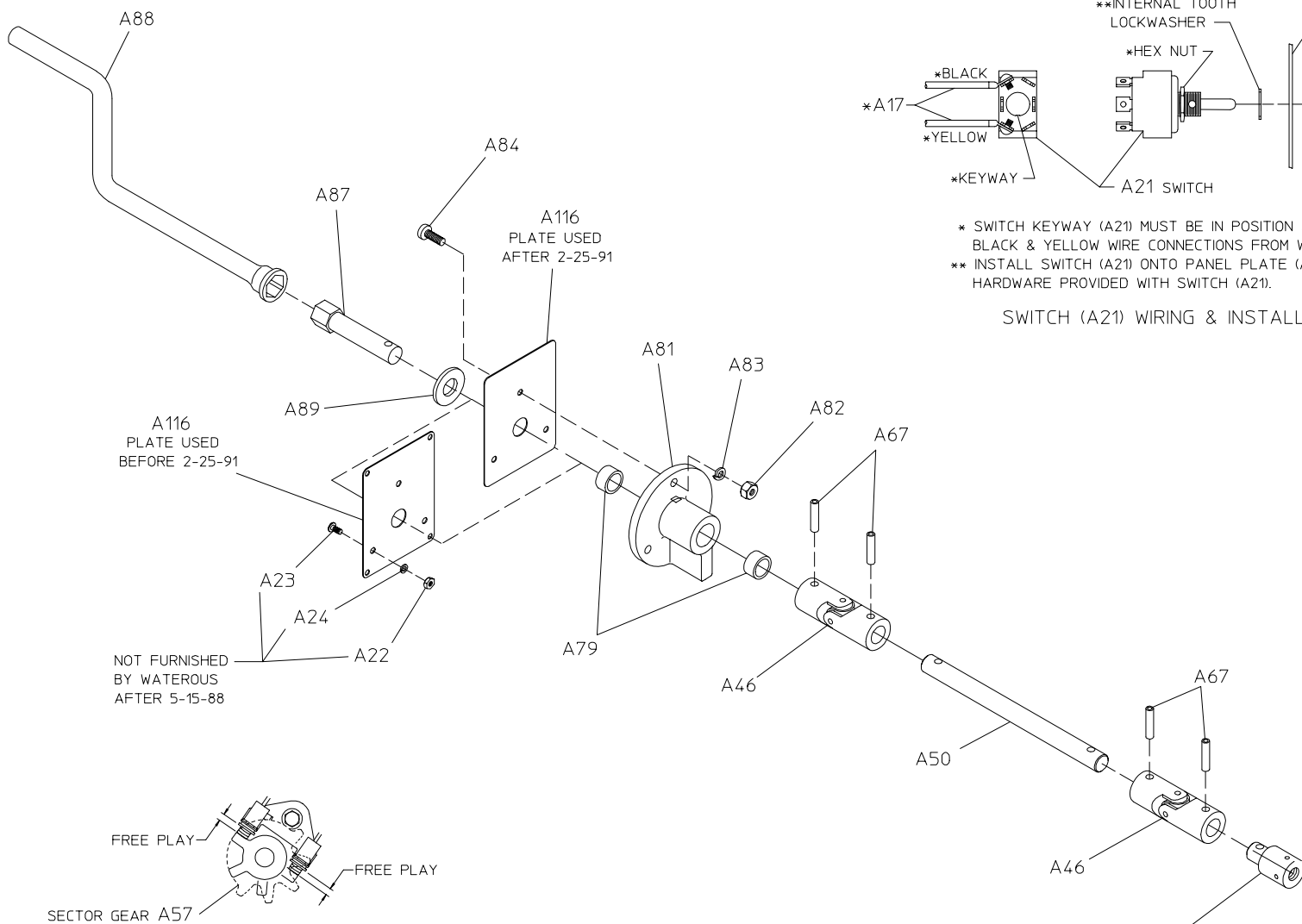

\* SWITCH KEYWAY (A21) MUST BE IN POSITION SHOWN WITH RESPECT TO BLACK & YELLOW WIRE CONNECTIONS FROM WIRING HARNESS (A17).  
 \*\* INSTALL SWITCH (A21) ONTO PANEL PLATE (A16) AS SHOWN WITH HARDWARE PROVIDED WITH SWITCH (A21).

SWITCH (A21) WIRING & INSTALLATION DETAIL

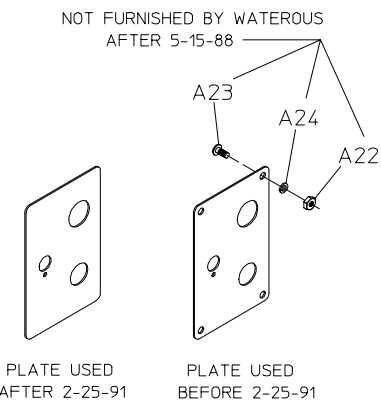

A16 PANEL PLATE DETAIL

NOT FURNISHED BY WATEROUS AFTER 5-15-88

A116 PLATE USED BEFORE 2-25-91

A116 PLATE USED AFTER 2-25-91

FREE PLAY

FREE PLAY

SEE PREVIOUS PAGES FOR DETAILS OF ACTUATOR ASSEMBLY

ADJUST TRAVEL OF ACTUATOR A107 BY TURNING PIVOT BLOCK BUSHING A7, SO THAT AFTER THE ACTUATOR HAS REACHED THE END OF ITS TRAVEL IN BOTH DIRECTIONS, THE SECTOR GEAR FREE PLAY IS EQUAL ON BOTH SIDES. LOCK PIVOT BLOCK BUSHING A7 IN PLACE WITH SET SCREWS A100.

**SECTOR GEAR A57 ADJUSTMENT**

**MANUAL OVERRIDE ASSEMBLY**

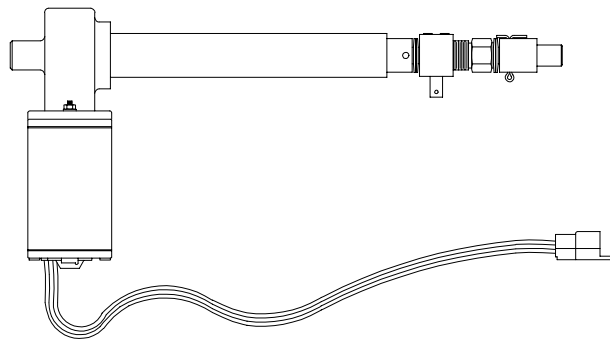

A107  
(COMPLETE ACTUATOR ASSEMBLY)

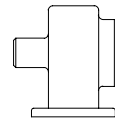

A126  
(GEARBOX ONLY)

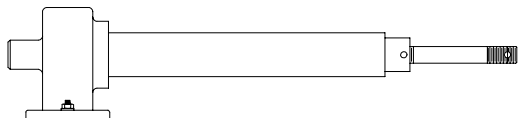

A127  
(ACTUATOR, LESS MOTOR ONLY)

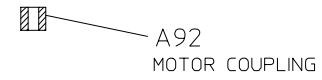

A92  
MOTOR COUPLING

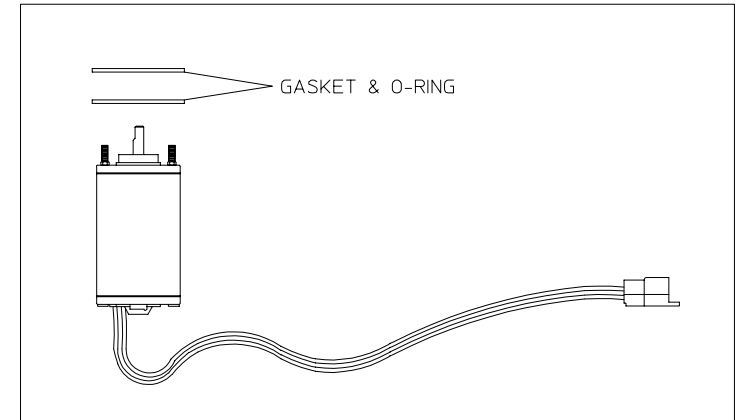

A91  
(MOTOR ONLY)