

Electric Shift Unit Service Parts List

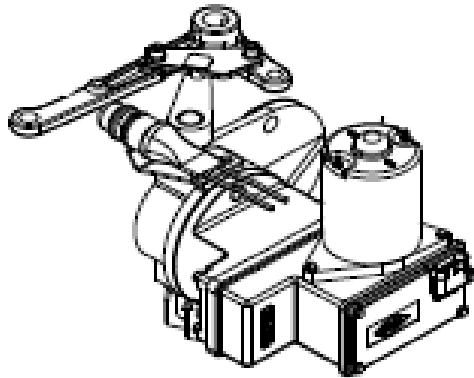

Index:

Item		See Page
Parts List		2
Single Shift Unit		3
Dual Shift Units	Front Shift Unit	4
	Rear Shift Unit	5
Wiring and Panel Plates <i>(Note that the wiring and panel plates may have been furnished by the truck builder)</i>		6

Parts List

Ref No.	Description
F1	Wire Assembly
F2	Wire Assembly
F3	Wire Assembly
F4	Panel plate
F5	Toggle switch
F6	Switch guard
F7	Circuit breaker, 12 volt, 15 amp
F13	Cable tie
F14	Shift unit, 12 volt or 24 volt
F19	Mounting bracket subassembly
F30	Lock washer, 7/16 in.
F40	Hex hd screw, 7/16-14 x 1 in.
F49	Motor and lube kit, 12 or 24 volt
F59	Shift override spring
F60	Cam
F61	Cam washer
F62	Pivot plate
F63	Arm assembly
F64	Lever
F65	Shift shaft
F66	Socket hd screw, 1/4-20 x 5/8 in.
F67	Cotter pin, 5/64 x 1/2 in.
F68	Dowel pin, 1/4 x 5/8 in.
F69	Clevis pin, 1/4 x 1-1/4

Ref No.	Description
F70	Spirol pin, 1/4 x 1-1/4 in.
F71	Socket hd screw, nylock, 1/4-20 x 1 in.
F72	Lock washer, 1/4 in.
F75	Shift pivot cover
F76	Gasket
F78	O-ring
F93	Switch bracket
F94	Push button switch
F95	Switch seal
F97	Wire assembly
F98	Flasher terminal block
F99	Flasher
F100	Wire assembly
F101	Wire assembly
F102	Green indicating light
F103	Red indicating light
F104	Bulb (12 volt, #1891) or 24 volt, #313)
F105	Panel plate
F106	Wire assembly
F107	Wire assembly
F108	Cover plate
F109	Switch cover
F110	Rubber grommet
F111	Hex mach nut, 1/4-20

Ref No.	Description
F113	Rnd hd screw, 1/4-20 x 5/8 in.
F114	Sleeve bearing
F115	Hex hd screw, 5/16-18 x 5/8 in.
F116	Seal plate
F117	Hex mach nut, 10-24
F118	Motor and bracket subassembly
F120	Wire assembly
F121	Wire assembly
F122	Wire assembly
F123	Circuit and cover kit
F125	Sleeve bearing

Single Shift Unit

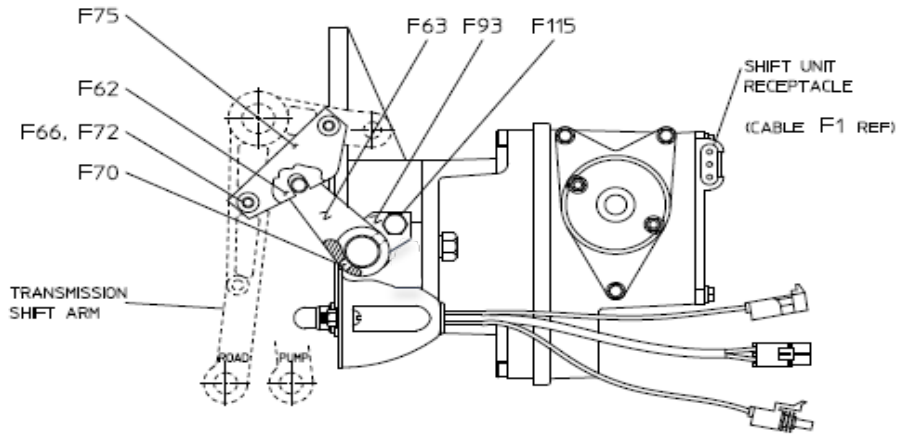

THIS MOUNTING ARRANGEMENT
USED WITH 9" OR NO BRAKE

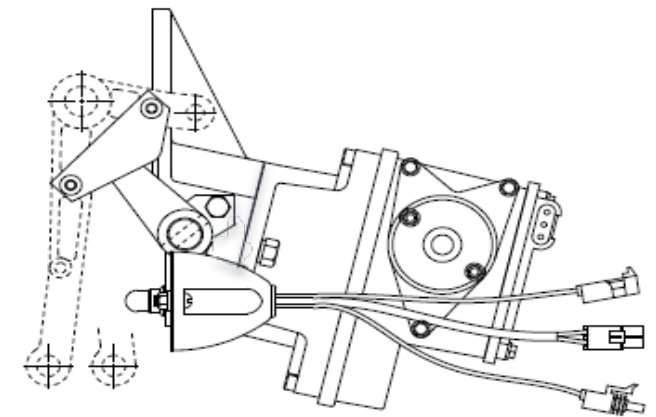

THIS MOUNTING ARRANGEMENT
USED WITH 12" BRAKE

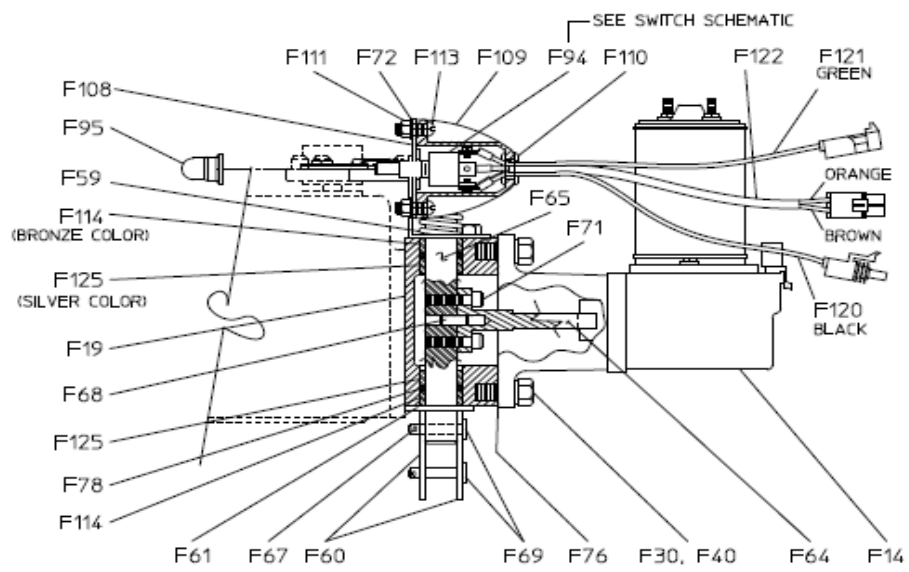

F118 MOTOR AND BRACKET ASSEMBLY
(LESS WIRING, SWITCHES, LIGHTS,
AND PANEL PLATES)

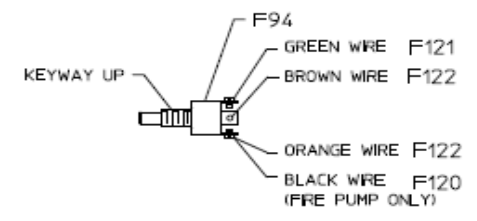

INDICATING LIGHT SWITCH SCHEMATIC

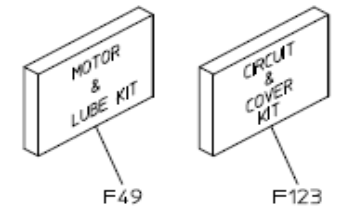

Dual Shift - Front Shift Unit

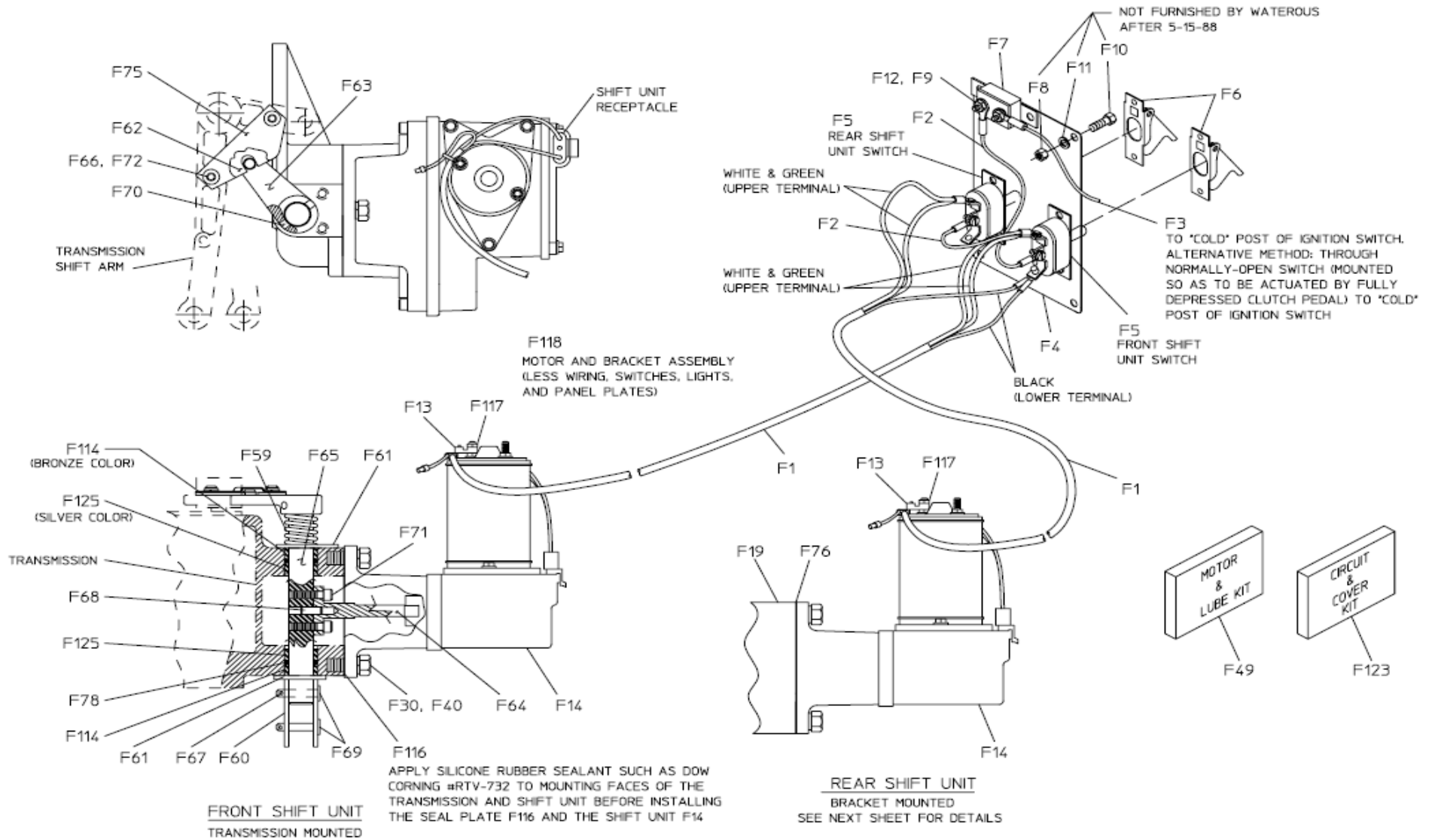

Dual Shift - Rear Shift Unit

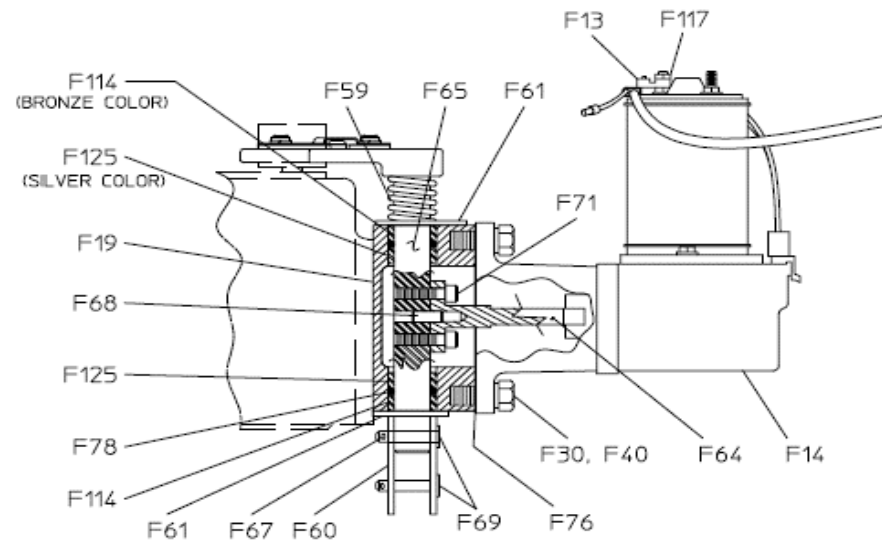
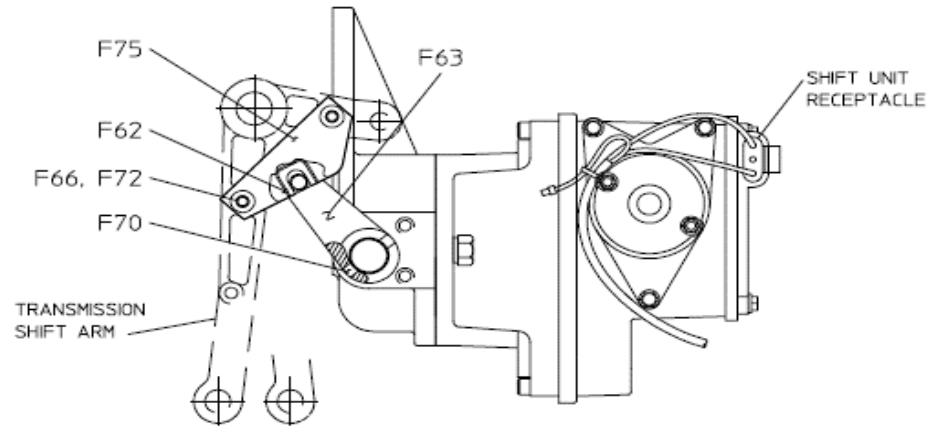

Wiring and Panel Plates

Note that the wiring and panel plates may have been furnished by the truck builder

