

Issued: 05/88
 Revised: 03/23/06



WATEROUS COMPANY
 SOUTH ST. PAUL, MINNESOTA

**CS SERIES IMPELLER SHAFT ASSEMBLIES
 FOR WATEROUS SINGLE AND TWO-STAGE FIRE PUMPS**

Pump Type	Pump and Transmission Model	Drive	Shaft		See Page for Diagram	
			Type	Spline	Packing	Mechanical Seal
Single Stage	CSWB, CSWK, CSYB Thru CSYF, CSUYB Thru CSUYF, CSK, CSUK	Rear	Separable	35 Tooth	4	5
				14 Tooth	6	7
	CSK1	Front	One-Piece	N/A	8	-
	CSD, CSUD	Front	One-Piece	N/A	9	12
Two Stage	CSHWB, CSHWK, CSHK, CSHM, CSHYB Thru CSHYF, CSUHYB Thru CSUHYF	Rear	One-Piece	N/A	10	-
		Front	One-Piece	N/A	11	-

PLEASE NOTE
WHEN ORDERING PARTS PLEASE SUPPLY PUMP SERIAL NUMBER

CS SERIES IMPELLER SHAFT ASSEMBLIES FOR WATEROUS SINGLE AND TWO-STAGE FIRE PUMPS

REF NO.	DESCRIPTION	REF NO.	DESCRIPTION
S2	Outboard bearing housing	S27	Grommet, flinger
S3	Outboard ball bearing	S28	Flinger disc
S4	Impeller, first stage	S29	Outboard cap
S5	Stuffing box end assembly	S30	Gasket
S6*	Packing, flexible graphite (Grafoil®), solid ring	S31	Square head pipe plug, steel, 1/4 in.
S7	Seal chamber cover	S32	Oil seal, 1-1/2 x 2-3/4 in., 1-5/8 x 2-3/4 in. or 1-7/16 x 2-3/4 in.
S7	Packing gland (2 halves)	S33	Lube relief fitting, 1/8 in.
S9	Square key, 5/16 x 1-9/16 or 2-5/16 in.	S34	Retaining ring
S10	Spirol pin, SS, 1/8 x 3/8 in.	S35	Lock washer, 3/8 in.
S11	Impeller shaft	S36	Hex hd cap screw, 3/8-16 x 1 in.
S12	Retaining ring	S37	Socket head cap screw, 5/16-18 x 1 or 1-1/4 in.
S13	Wear ring (std, 0.025, 0.050 and 0.075 in. U/S)	S38	Tachometer driven gear
S14	Square key, SS, 5/16 x 2-3/4 in.	S39	Gasket
S15	Lubrication fitting, 1/8 in.	S40	Lock washer, 5/16 in.
S16	Hex hd cap screw, 1/2-13 x 1-1/4 in., grade 5	S42	Ball bearing
S17	Lock washer, 1/2 in.	S45	Cap screw, 1/2-20 x 1-3/4 in., grade 5
S18	Hex castle nut, SS, 3/4-16	S46	Hex nut, 1/2-20
S19	Cotter pin, SS, 1/8 x 1 in.	S47	Tachometer drive gear
S20	Bearing housing	S48	Tachometer gear spacer
S21	High pressure impeller	S49	Tachometer gear bushing
S22	Flinger ring	S50	Retaining ring
S23	Ball bearing, double row	S51	O-ring, 3-1/4 x 3-1/2 in.
S24	Retaining ring	S52	Spring pin, 3/16 x 1/2 in.
S25	Impeller spacer	S53	Oil seal, 1-23/32 x 2-3/4 in.
S26	Packing, soft ring		

**CS SERIES IMPELLER SHAFT ASSEMBLIES
FOR WATEROUS SINGLE AND TWO-STAGE FIRE PUMPS**

REF NO.	DESCRIPTION	REF NO.	DESCRIPTION
S54	End yoke with U-bolts	S70	Housing spacer
S55	Shaft nut, 1-20	S71	Bearing spacer
S56	Cotter pin, 1/8 x 1-3/4 in.	S72*	Packing, flexible graphite (Grafoil®), split ring
S57	Tachometer sleeve	S73	Bearing seal (used after 12/18/92)
S64	Mechanical seal (Refer to S95 or S96)	S74	Retaining ring
S65	Retaining ring	S75	Bearing housing plug
S66	Throttle bushing (not used on bronze body pumps)	S76	Bearing shield
S67	Flat washer, 5/16 in., zinc plated	S95	Repair kit, mechanical seal, outboard end
S68	Tachometer gear housing assembly	S96	Repair kit, mechanical seal, drive end
S69	Flinger	S97*	Bearing spacer (used after 12/18/92)

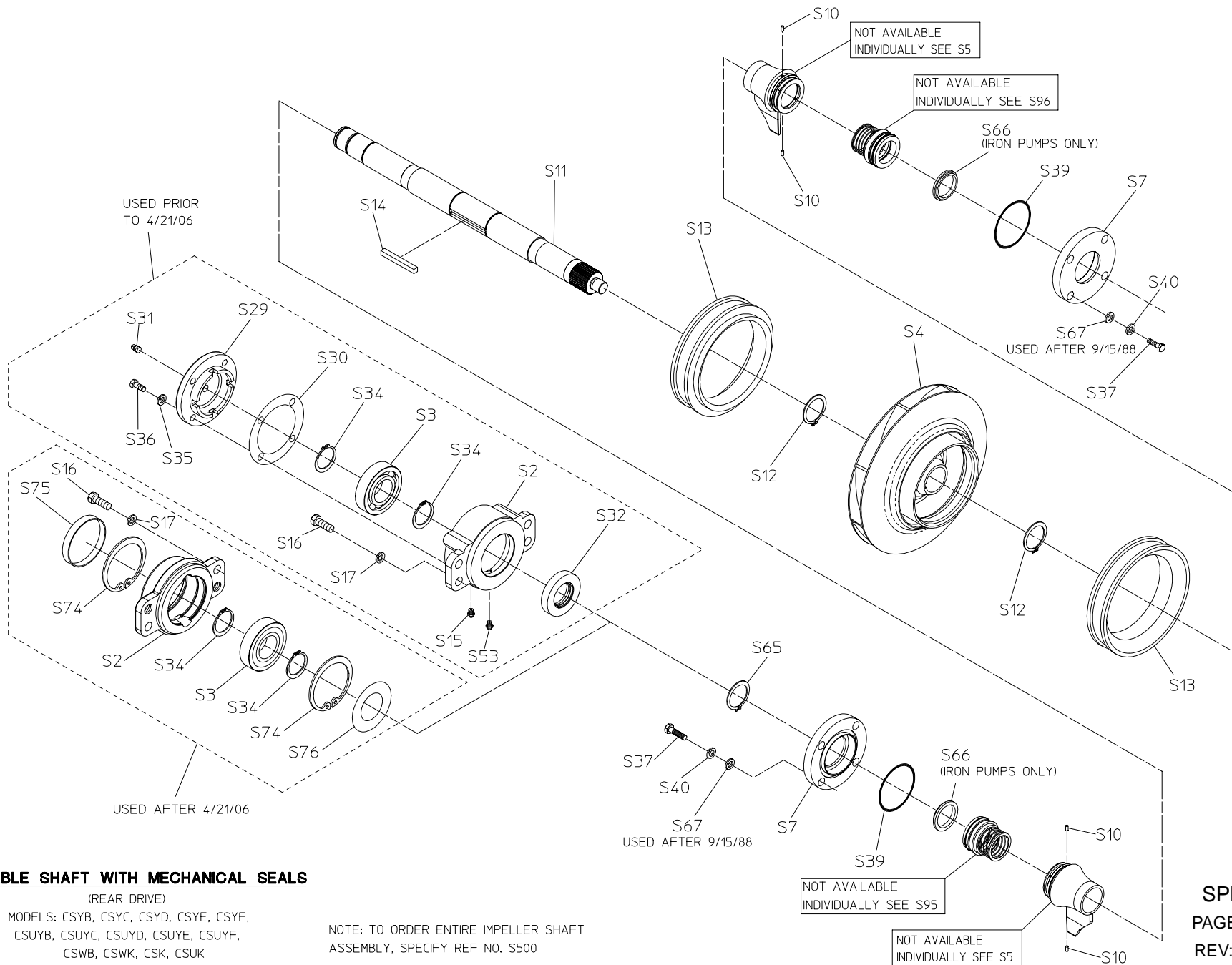

SEPARABLE SHAFT WITH MECHANICAL SEALS

(REAR DRIVE)

MODELS: CSYB, CSYC, CSYD, CSYE, CSYF,
 CSUYB, CSUYC, CSUYD, CSUYE, CSUYF,
 CSWB, CSWK, CSK, CSUK

NOTE: TO ORDER ENTIRE IMPELLER SHAFT
 ASSEMBLY, SPECIFY REF NO. S500

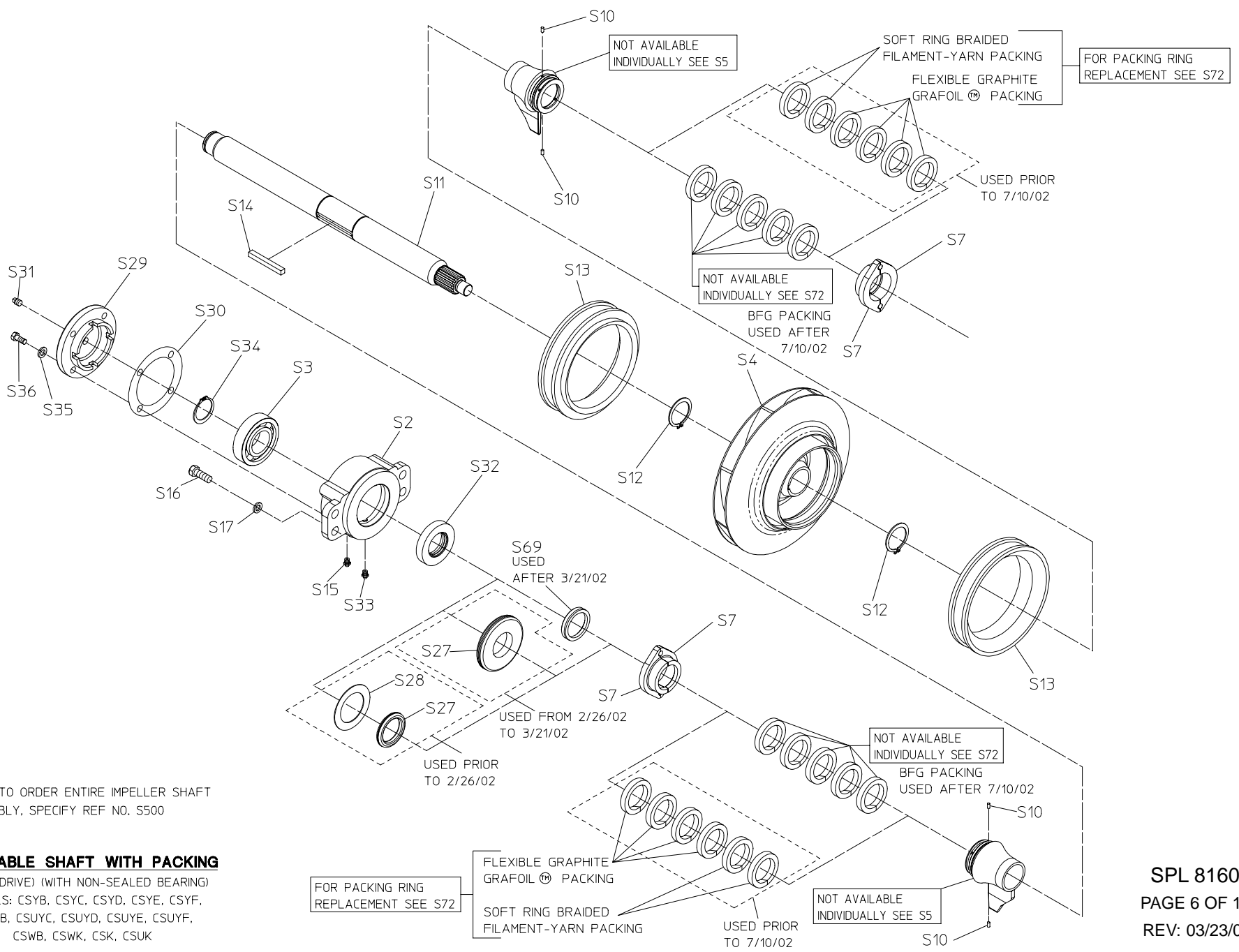

NOTE: TO ORDER ENTIRE IMPELLER SHAFT ASSEMBLY, SPECIFY REF NO. S500

SEPARABLE SHAFT WITH PACKING
 (REAR DRIVE) (WITH NON-SEALED BEARING)
 MODELS: CSYB, CSYC, CSYD, CSYE, CSYF,
 CSUYB, CSUYC, CSUYD, CSUYE, CSUYF,
 CSWB, CSWK, CSK, CSUK

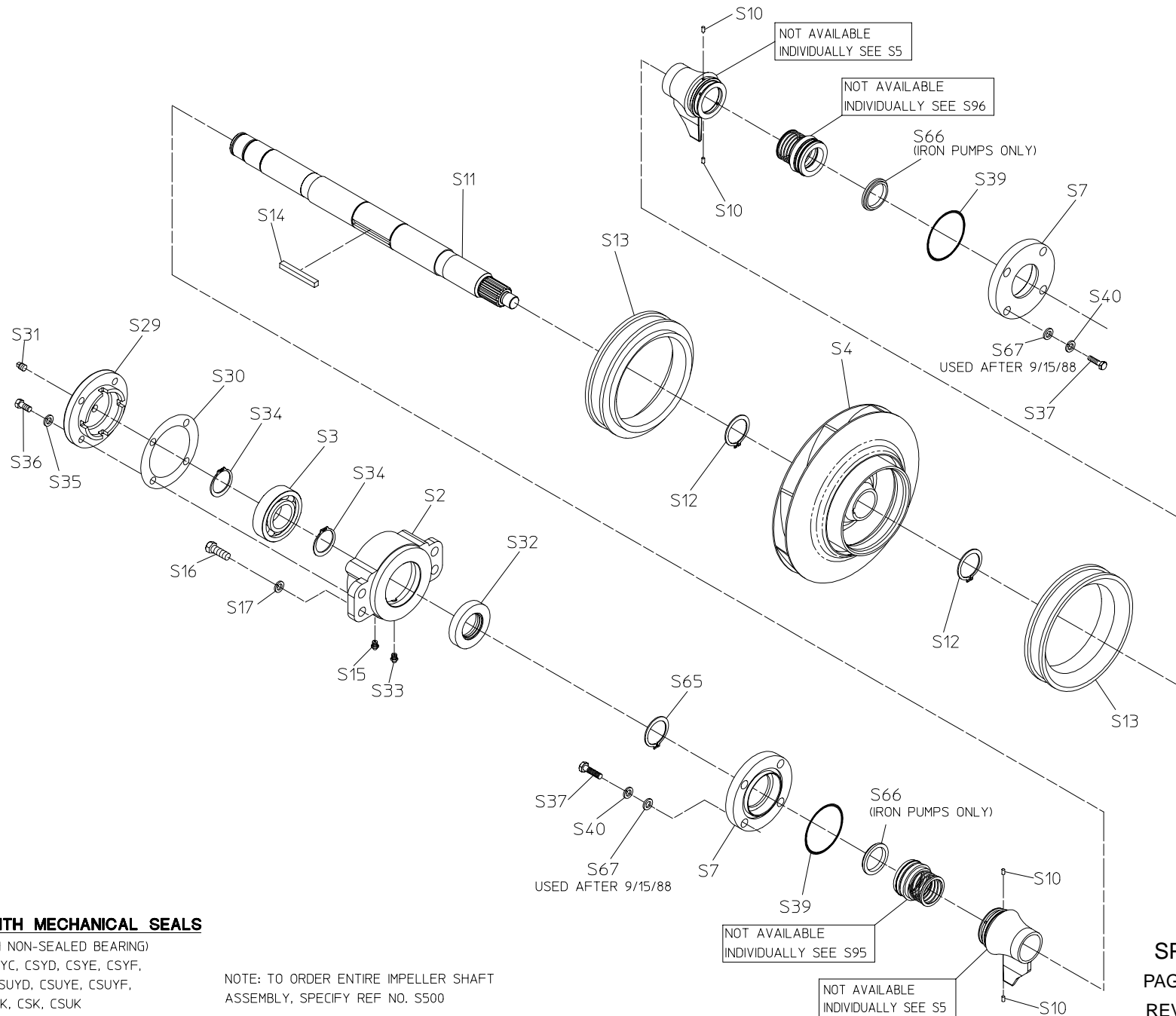

SEPARABLE SHAFT WITH MECHANICAL SEALS

(REAR DRIVE) (WITH NON-SEALED BEARING)
 MODELS: CSYB, CSYC, CSYD, CSYE, CSYF,
 CSUYB, CSUYC, CSUYD, CSUYE, CSUYF,
 CSWB, CSWK, CSK, CSUK

NOTE: TO ORDER ENTIRE IMPELLER SHAFT
 ASSEMBLY, SPECIFY REF NO. S500

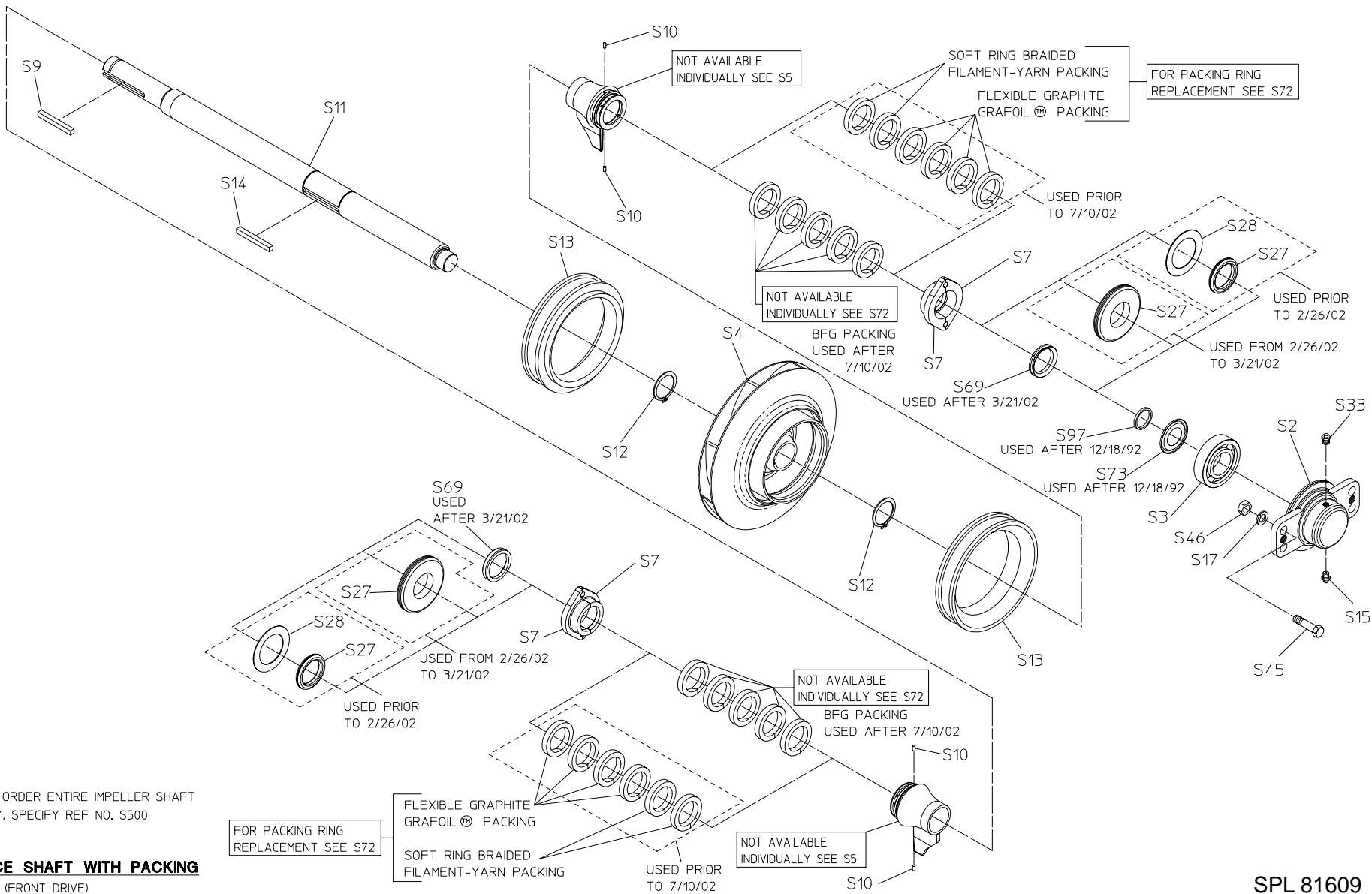

NOTE: TO ORDER ENTIRE IMPELLER SHAFT ASSEMBLY, SPECIFY REF NO. S500

ONE-PIECE SHAFT WITH PACKING

(FRONT DRIVE)
MODEL: CSK1

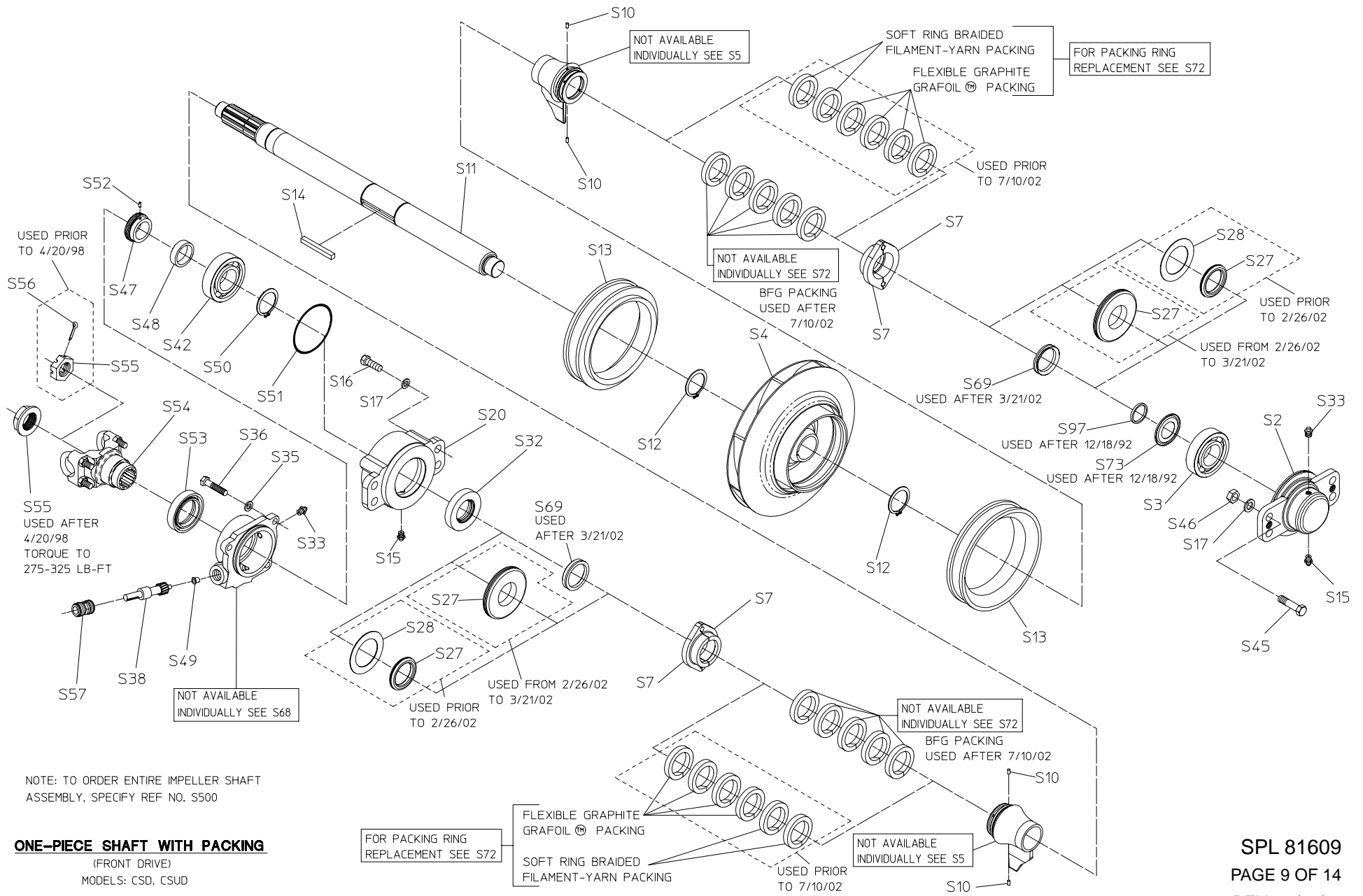

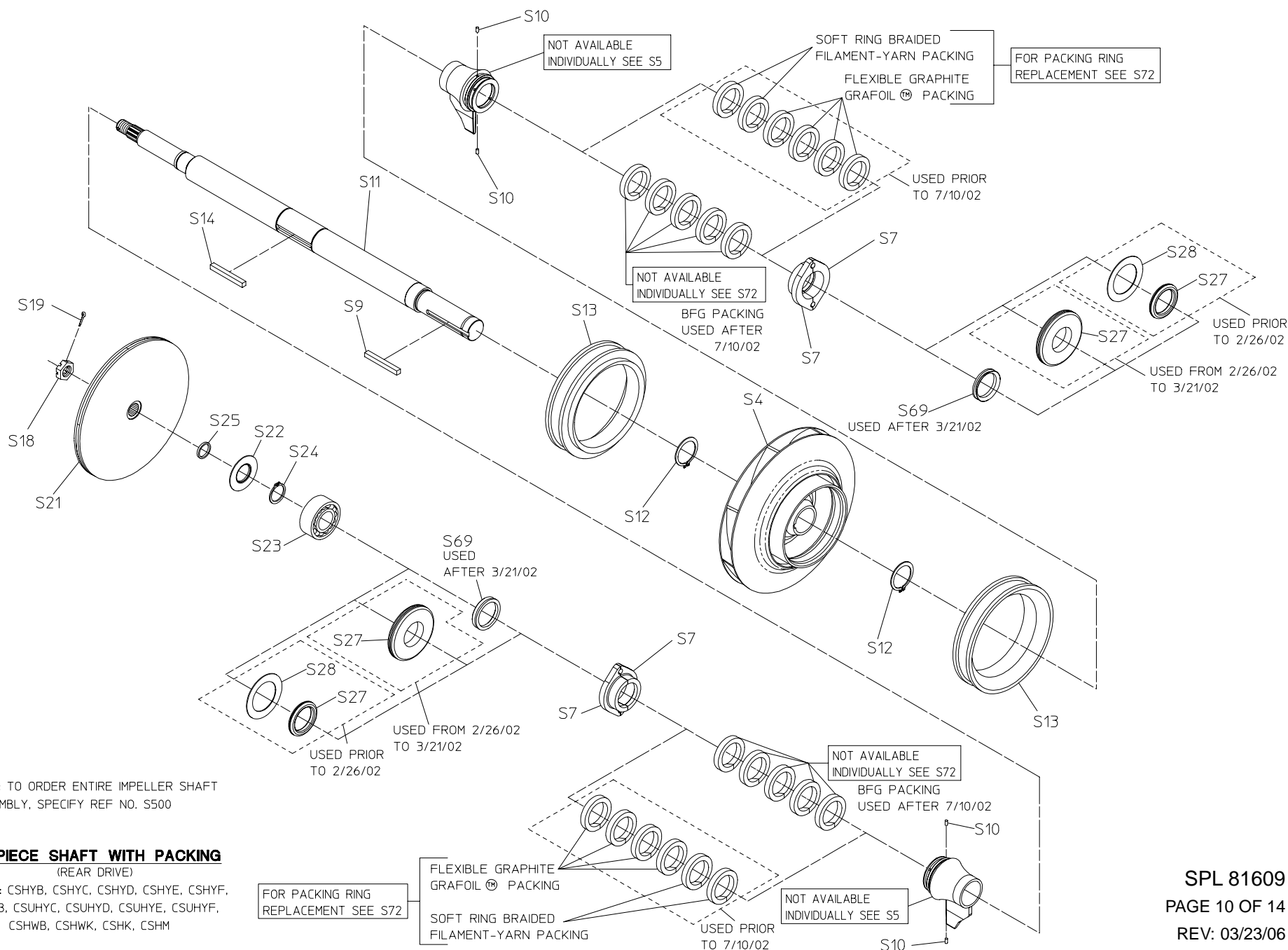

NOTE: TO ORDER ENTIRE IMPELLER SHAFT ASSEMBLY, SPECIFY REF NO. S500

ONE-PIECE SHAFT WITH PACKING
(REAR DRIVE)

MODELS: CSHYB, CSHYC, CSHYD, CSHYE, CSHYF, CSUHYB, CSUHYC, CSUHYD, CSUHYE, CSUHYF, CSHWB, CSHWK, CSHK, CSHM

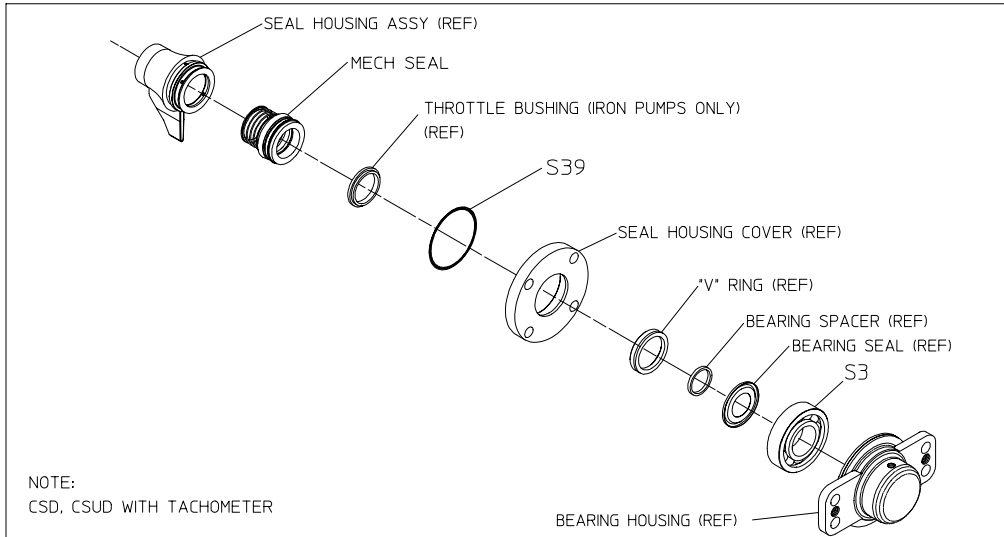

REF NO. S95 SEAL REPLACEMENT KIT CSD PUMPS W/ TACHOMETER (OUTBOARD END)

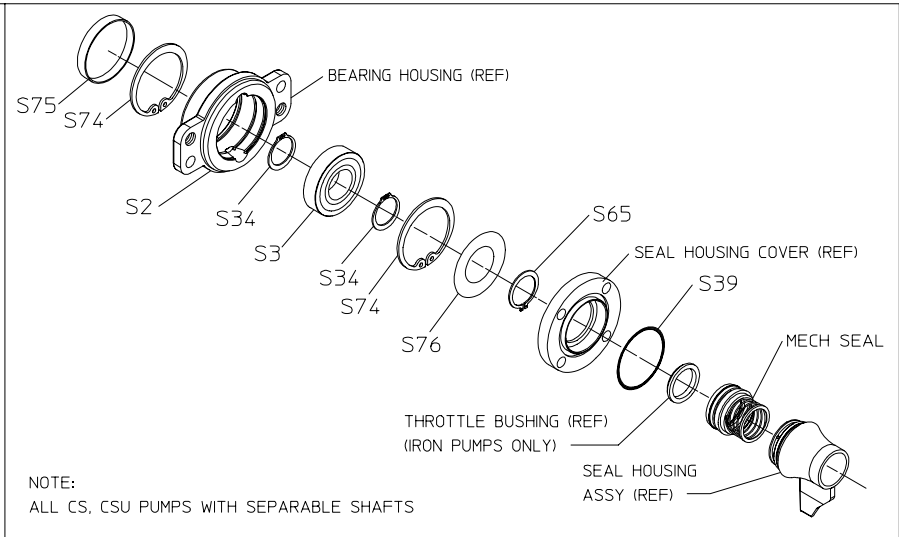

REF NO. S95 SEAL REPLACEMENT KIT (OUTBOARD END W/SEALED BEARING)

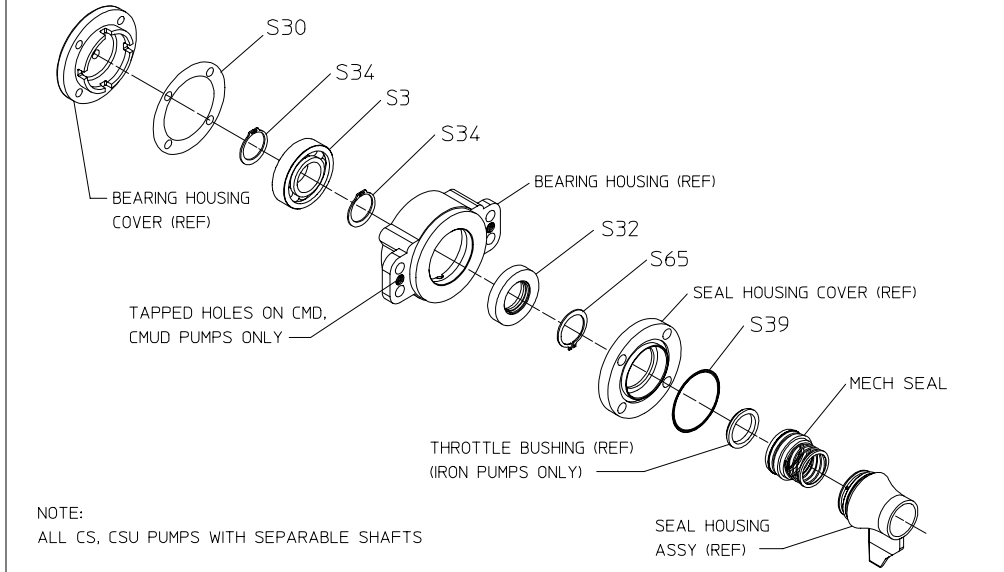

REF NO. S95 SEAL REPLACEMENT KIT (OUTBOARD END)

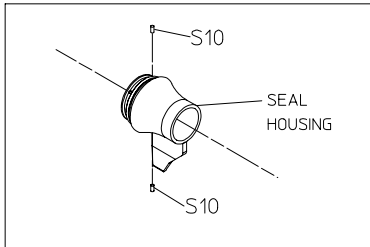

REF NO. S5 SEAL HOUSING ASSEMBLY

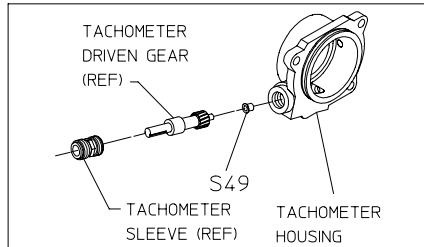

REF NO. S68 TACHOMETER GEAR HOUSING ASSEMBLY

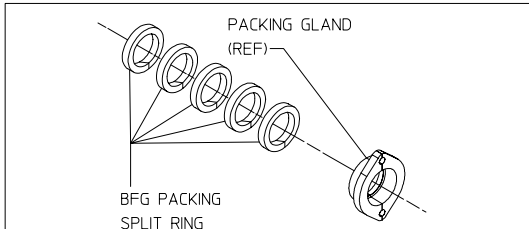

REF NO. S72 SPLIT PACKING REPLACEMENT KIT

NOTE:
ALL PARTS LABELED WITH (REF) ARE NOT INCLUDED IN REPLACEMENT KIT, AND ARE SHOWN FOR REFERENCE ONLY.

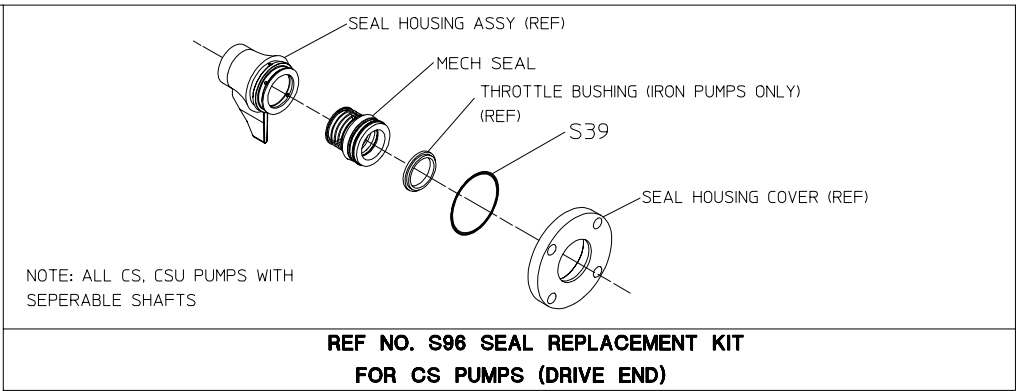
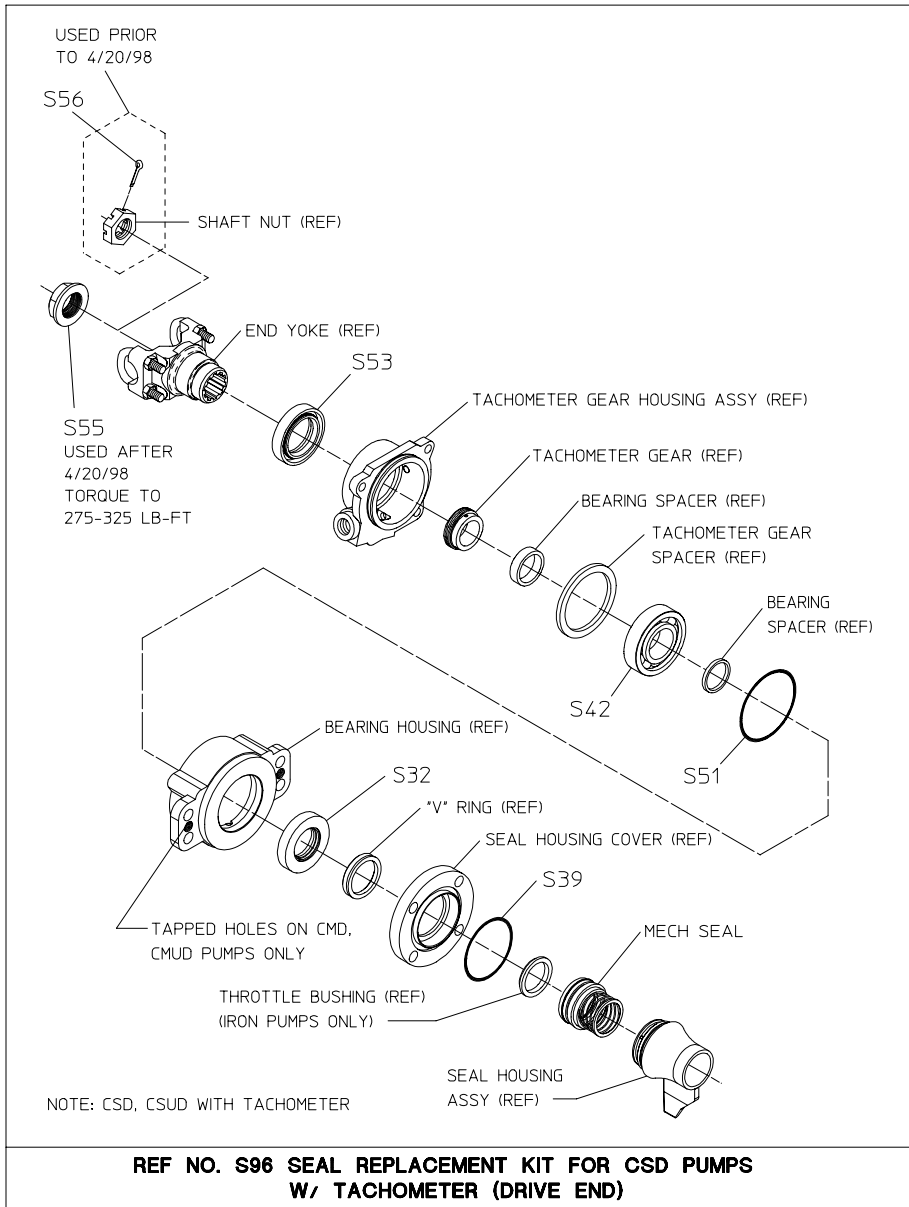

NOTE:
ALL PARTS LABELED WITH (REF) ARE NOT INCLUDED IN REPLACEMENT KIT, AND ARE SHOWN FOR REFERENCE ONLY.