

## E500 Series Motor Pump Service Parts List

### Index:

Pump and Engine						
Pump Model <i>(Located on Serial Plate)</i>	See Pages					
	Pump				Engine	
	E501	E511	Mounting on Engine	Discharge Position	Diesel -A	Gasoline -B
<b>E501-A</b> <i>(Diesel Engine)</i>	2-5	-	10, 11	12, 13	14, 15	-
<b>E511-A</b> <i>(Diesel Engine)</i>	-	6-9	10, 11	12, 13	14, 15	-
<b>E511-B</b> <i>(Gasoline Engine)</i>	-	6-9	10, 11	12, 13	-	16, 17

Optional Instrument Panels							
Pump Model	Panel Type	See Pages					
		Connection to Pump	Main Panel		In-Cab Panel		Engine Wiring Schematic
			Panel Components	Wiring Schematic	Panel Components	Wiring Schematic	
<b>E501-A or E511-A</b>	Single Municipal	18, 19	26, 27	28, 29	-	-	42, 43
	Dual Municipal	20, 21	26, 27	28, 29	30, 31	32, 33	42, 43
	Deluxe	22, 23	34, 35	36, 37	-	-	44, 45
<b>E511-B</b>	Single Municipal	24, 25	38, 39	40, 41	-	-	46, 47

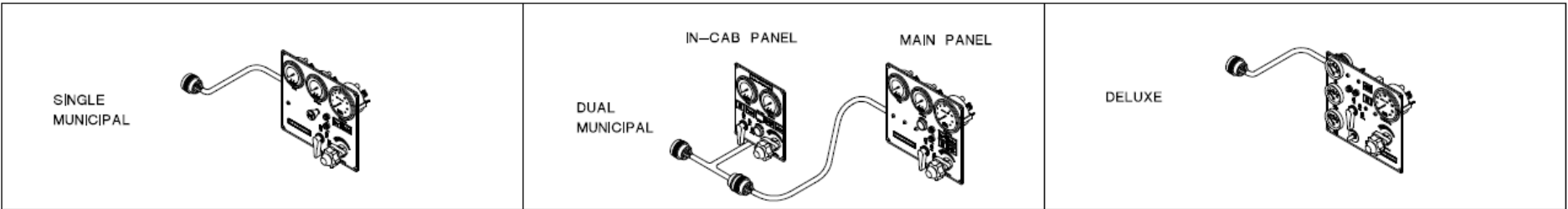

## E501 Pump

REF NO.	DESCRIPTION	QTY
21	Hex Hd Screw, 7/16-20 x 3 in.	1
22	Hex Hd Screw, 7/16-20 x 2-3/4 in.	3
23	Volute Body Subassembly (Includes 38, Wear Ring)	1
24	Pipe plug, 1/4 in. NPT	5
25	Mechanical Seal	1
26	O-ring, 5-3/4 x 6 in.	1
27	Gear Case Cover (Includes 38, Wear Ring After April 17, 1998)	1
28	Lock Washer, 7/16	4
29	Hex Nut, 7/16 in.	4
30	Oil Seal	1
31	Ball Bearing	1
32	Retaining Ring (Prior to April 17, 1998)	1
33	Driven Shaft/Gear	1
34	Drain Cock	1
35	Soc Hd Screw, 1/4-20 x 3/4 in.	4
38	Wear Ring (Prior to April 17, 1998)	1
38	Wear Ring (After April 17, 1998)	2
39	Impeller Nut (Prior to February 1, 2002)	1
39	Hex Nut – Thin Nylok, 1/2-20 (After February 1, 2002 – Prior to September 8, 2004)	1
39	Hex Nut, 1/2-20 (After September 8, 2004)	1
40	Flat Washer, 1/2 in., ss (Prior to September 8, 2004)	1
40	Washer, Nord-Lock®, 1/2 in. (After September 8, 2004)	1
41	Impeller	1
42	Square Key, 3/16 x 1 in., ss	1
43	Magnetic Pipe Plug, 3/8 in., NPT	1
44	Hex Hd Screw, 3/8-16 x 1 in.	10
45	Lock Washer, 3/8 in.	10
46	Gear Case Gasket	1
47	Needle Bearing (Prior to April 17, 1998)	1

REF NO.	DESCRIPTION	QTY
47	Needle/Thrust Bearing (After April 17, 1998)	2
48	Retaining Ring (Prior to February 1, 2002)	1
49	Square Key, 1/4 x 1-1/2 in. (Prior to February 1, 2002)	1
49	Chamfered Square Key, 1/4 x 1-1/8 in. (After February 1, 2002)	1
50	Spacer (Prior to April 17, 1998)	1
51	Needle Bearing (Prior to April 17, 1998)	1
52	Drive Screw, #6 x 1/4 in. (4, Prior to December 16, 1998)	2
53	Oil Level Plate (Prior to December 16, 1998)	1
54	Pipe Plug, 3/8 in. NPT	3
55	Gear Case	1
56	Drive Gear	1
57	Oil Seal	1
58	Socket Hd Screw, 3/8-16 x 2-1/2 in. (Prior to April 18, 2007)	4
59	Dowel Pin, 1/4 x 3/4 in. ss (Prior to April 17, 1998)	2
59	Dowel Pin, 5/16 x 3/4 in. ss (After April 17, 1998)	2
60	Flat Washer, 3/8 in. Copper	4
61	Serial Plate	1
62	90 Deg. Pipe Elbow, 3/8 in. NPT x 3 in. (Prior to May 19, 2005)	1
63	Pipe Nipple, 3/8 in. NPT x 3 in. (Prior to May 19, 2005)	1
64	Breather	1
121	Socket Hd Screw, 3/8-16 x 1-3/4 (After April 18, 2001)	4
123	1-1/2 in. NPT (F) Discharge Adapter	1
124	O-ring, 2-1/8 x 1-15/16 in.	1
126	Hex Nut – Thin Nylok, 1-14 (After February 1, 2002)	1
127	Impeller Gasket (After September 8, 2004)	1



## E501 Pump Sectional View

REF NO.	DESCRIPTION	QTY
21	Hex Hd Screw, 7/16-20 x 3 in.	1
22	Hex Hd Screw, 7/16-20 x 2-3/4 in.	3
23	Volute Body Subassembly (Includes 38, Wear Ring)	1
24	Pipe plug, 1/4 in. NPT	5
25	Mechanical Seal	1
26	O-ring, 5-3/4 x 6 in.	1
27	Gear Case Cover (Includes 38, Wear Ring After April 17, 1998)	1
28	Lock Washer, 7/16	4
29	Hex Nut, 7/16 in.	4
30	Oil Seal	1
31	Ball Bearing	1
33	Driven Shaft/Gear	1
34	Drain Cock	1
38	Wear Ring (Prior to April 17, 1998)	1
38	Wear Ring (After April 17, 1998)	2
39	Impeller Nut (Prior to Februry 1, 2002)	1
39	Hex Nut – Thin Nylok, 1/2-20 (After February 1, 2002)	1
40	Flat Washer, 1/2 in., ss (Prior to September 8, 2004)	1
40	Washer, Nord-Lock®, 1/2 in. (After September 8, 2004)	1
41	Impeller	1
42	Square Key, 3/16 x1 in., ss	1
43	Magnetic Pipe Plug, 3/8 in., NPT	1
44	Hex Hd Screw, 3/8-16 x 1 in.	10
45	Lock Washer, 3/8 in.	10
46	Gear Case Gasket	1
47	Needle Bearing (Prior to April 17, 1998)	1

REF NO.	DESCRIPTION	QTY
47	Needle/Thrust Bearing (After April 17, 1998)	2
49	Square Key, 1/4 x 1-1/2 in. (Prior to February 1, 2002)	1
49	Chamfered Square Key, 1/4 x 1-1/8 in. (After February 1, 2002)	1
52	Drive Screw, #6 x 1/4 in. (4, Prior to December 16, 1998)	2
54	Pipe Plug, 3/8 in. NPT	3
55	Gear Case	1
56	Drive Gear	1
57	Oil Seal	1
58	Socket Hd Screw, 3/8-16 x 2-1/2 in. (Prior to April 18, 2007)	4
59	Dowel Pin, 1/4 x 3/4 in. ss (Prior to April 17, 1998)	2
59	Dowel Pin, 5/16 x 3/4 in. ss (After April 17, 1998)	2
60	Flat Washer, 3/8 in. Copper	4
61	Serial Plate	1
62	90 Deg. Pipe Elbow, 3/8 in. NPT x 3 in. (Prior to May 19, 2005)	1
63	Pipe Nipple, 3/8 in. NPT x 3 in. (Prior to May 19, 2005)	1
64	Breather	1
67	Pump Subassemby	1
76	Drive Shaft	1
103	Engine Adapter Bushing (After April 18, 2001)	1
104	Pump Sub-Assy (For Repairs Only)	1
126	Hex Nut – Thin Nylok, 1-14 (After February 1, 2002)	1
127	Impeller Gasket (After September 8, 2004)	1

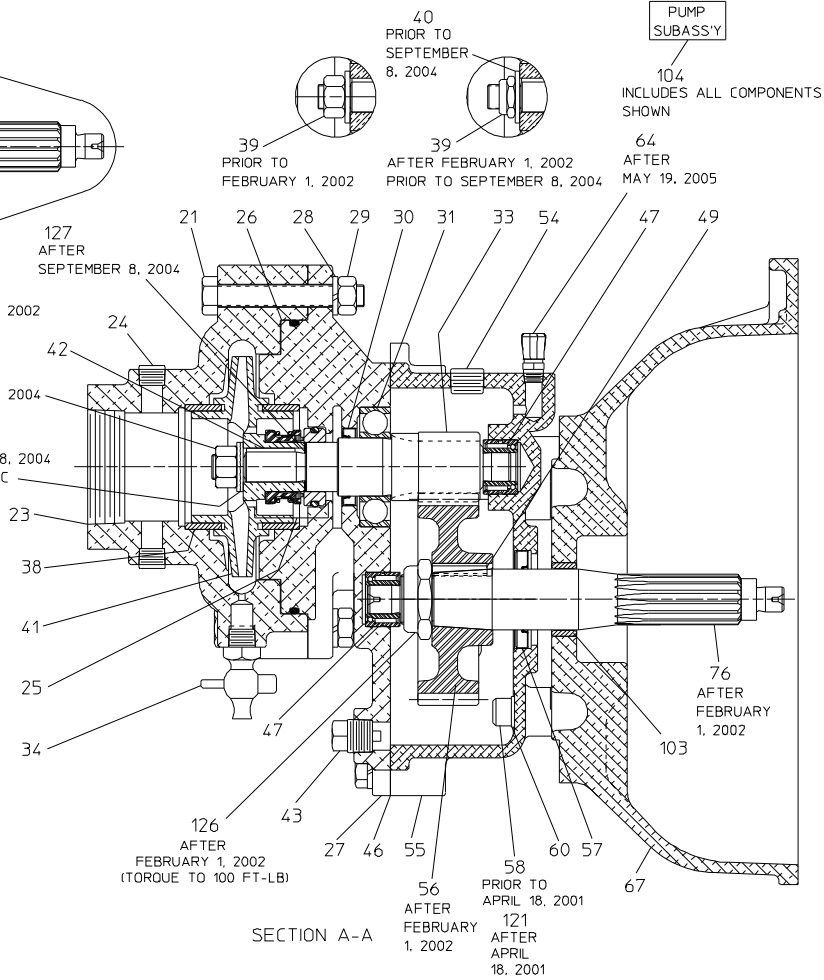
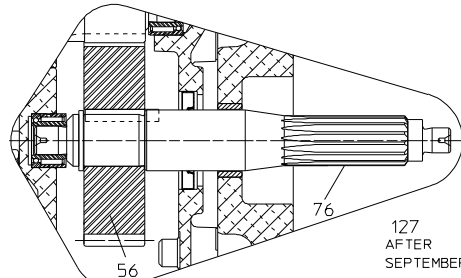
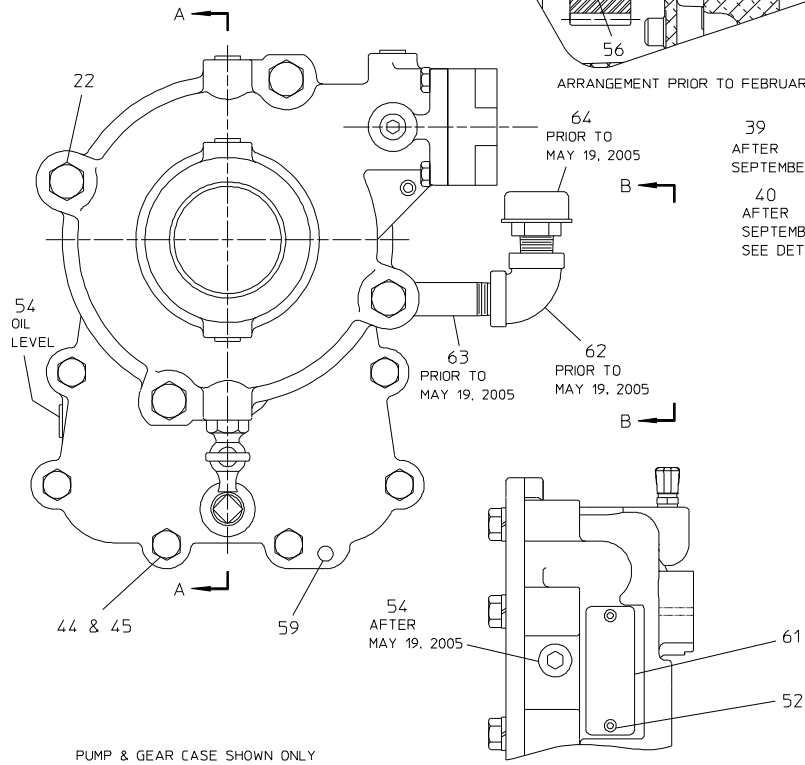
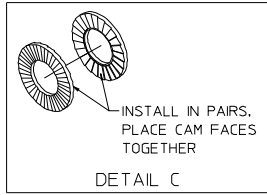

**E501 PUMP SECTIONAL VIEW**  
ALL PARTS SHOWN ARE AVAILABLE AS A SUB-ASSEMBLY REF NO. 104 (FOR SERVICE ONLY)

## E511 Pump

REF NO.	DESCRIPTION	QTY
23	Volute Body Subassembly (Includes Pipe Plug 24, Wear Ring38 and Stud 136)	1
24	Pipe plug, 1/4 in. NPT	4
25	Mechanical Seal	1
26	O-ring, 5-3/4 x 6 in.	1
27	Gear Case Cover	1
28	Lock Washer, 7/16	4
29	Hex Nut, 7/16-20	4
30	Oil Seal	1
31	Ball Bearing	1
33	Impeller Shaft Assembly (Includes Bearing)	1
34	Drain Cock	1
38	Wear Ring	1
39	Lock Nut, 3/4-16 (Prior to May 1, 2002)	1
39	Hex Nut – Thin Nylok, 3/4-16 (After May 1, 2002)	1
40	Flat Washer, 3/4 in. (Prior to January 31, 2005)	1
40	Washer, Nord-Lock®, 3/4 in. (After January 31, 2005)	1
41	Impeller	1
42	Square Key, 3/16 x1 in., ss	1
43	Magnetic Pipe Plug, 3/8 in., NPT	1
44	Hex Hd Screw, 3/8-16 x 1 in.	10
45	Lock Washer, 3/8 in.	10
46	Gear Case Gasket	1
47	Needle Bearing	2
47	Needle Bearing (Prior to April 17, 1998)	1
48	Retaining Ring (Prior to May 1, 2002)	1

REF NO.	DESCRIPTION	QTY
49	Square Key, 1/4 x 1-1/2 in. (Prior to May 1, 2002)	1
49	Square Key, 1/4 x 1-1/2 in. (Prior to May 1, 2002)	1
49	Chamfered Square Key, 1/4 x 1-1/8 in. (After May 1, 2002)	1
52	Drive Screw, #6 x 1/4 in. (4, Prior to December 16, 1998)	2
53	Oil Level Plate (Prior to December 16, 1998)	1
54	Pipe Plug, 3/8 in. NPT	5 or 6
55	Gear Case	1
56	Drive Gear	1
57	Oil Seal	1
58	Socket Hd Screw, 3/8-16 x 2-1/2 in. (Prior to 4/18/01)	4
59	Dowel Pin, 5/16 x 3/4 in. ss	2
60	Flat Washer, 3/8 in. Copper	4
61	Serial Plate	1
62	90 Deg. Pipe Elbow, 3/8 in. NPT x 3 in. (Prior to May 19, 2005)	1
63	Pipe Nipple, 3/8 in. NPT x 3 in. (Prior to May 19, 2005)	1
64	Breather	1
106	Headless Pipe Plug, 1/8 NPT	1
115	Retaining Ring	1
121	Socket Hd Screw, 3/8-16 x 1-3/4 (After April 18, 2001)	4
126	Hex Nut – Thin Nylok, 1-14 (After May 1, 2002)	1
136	Stud, 7/16-14 x 7-16-20 x 2 in.	4
137	Adapter, 2in. NPT x 2 in. Victaulic (Optional)	0 or 1
138	Adapter, 3 in. NPT x 3 in. Victaulic (Optional)	0 or 1



## E511 Pump Sectional View

REF NO.	DESCRIPTION	QTY
23	Volute Body Subassembly (Includes Pipe Plug 24, Wear Ring 38 and Stud 136)	1
24	Pipe plug, 1/4 in. NPT	4
25	Mechanical Seal	1
26	O-ring, 5-3/4 x 6 in.	1
27	Gear Case Cover	1
28	Lock Washer, 7/16	4
29	Hex Nut, 7/16-20	4
30	Oil Seal	1
31	Ball Bearing	1
33	Impeller Shaft Assembly (Includes Bearing)	1
34	Drain Cock	1
38	Wear Ring	2
39	Lock Nut, 3/4-16 (Prior to May 1, 2002)	1
39	Hex Nut – Thin Nylok, 3/4-16 (After May 1, 2002)	1
40	Flat Washer, 3/4 in. (Prior to January 31, 2005)	1
40	Washer, Nord-Lock®, 3/4 in. (After January 31, 2005)	1
41	Impeller	1
42	Square Key, 3/16 x 1 in., ss	1
43	Magnetic Pipe Plug, 3/8 in., NPT	1
44	Hex Hd Screw, 3/8-16 x 1 in.	10
45	Lock Washer, 3/8 in.	10
46	Gear Case Gasket	1
47	Needle Bearing	2
48	Retaining Ring (Prior to May 1, 2002)	1
49	Square Key, 1/4 x 1-1/2 in. (Prior to May 1, 2002)	1
49	Chamfered Square Key, 1/4 x 1-1/8 in. (After May 1, 2002)	1
52	Drive Screw, #6 x 1/4 in. (4, Prior to December 16, 1998)	2
53	Oil Level Plate (Prior to December 16, 1998)	1
54	Pipe Plug, 3/8 in. NPT	5 or 6

REF NO.	DESCRIPTION	QTY
55	Gear Case	1
56	Drive Gear	1
57	Oil Seal	1
58	Socket Hd Screw, 3/8-16 x 2-1/2 in. (Prior to April 18, 2001)	4
59	Dowel Pin, 5/16 x 3/4 in. ss	2
60	Flat Washer, 3/8 in. Copper	4
61	Serial Plate	1
62	90 Deg. Pipe Elbow, 3/8 in. NPT (Prior to May 19, 2005)	1
63	Pipe Nipple, 3/8 in. NPT x 3 in. (Prior to May 19, 2005)	1
64	Breather	1
67	Engine Adapter	1
76	Drive Shaft	1
103	Engine Adapter Bushing (After April 18, 2001)	1
104	Pump Sub-Assy (For Repairs Only)	0
106	Headless Pipe Plug, 1/8 NPT	1
115	Retaining Ring	1
121	Socket Hd Screw, 3/8-16 x 1-3/4 (After April 18, 2001)	4
126	Hex Nut – Thin Nylok, 1-14 (After May 1, 2002)	1
136	Stud, 7/16-14 x 7-16-20 x 2 in.	4



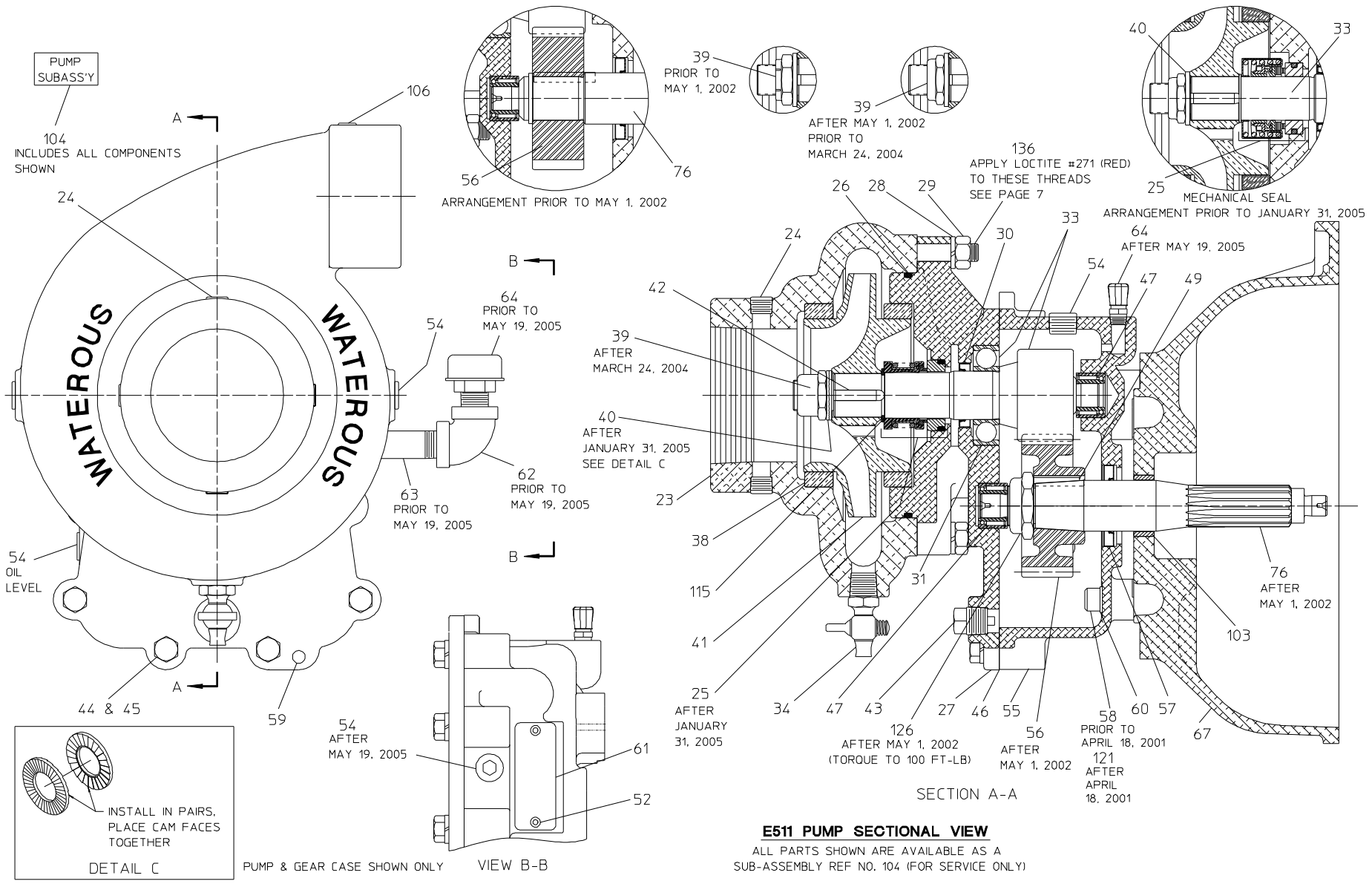

**E511 PUMP SECTIONAL VIEW**  
 ALL PARTS SHOWN ARE AVAILABLE AS A  
 SUB-ASSEMBLY REF NO. 104 (FOR SERVICE ONLY)

## Pump to Engine Mounting (All Models)

REF NO.	DESCRIPTION	QTY
67	Engine Adapter	1
68	Soc Hd Screw, M10 – 1.25 x 40mm	4
69	Lock Washer, 10mm	4
70	Soc Hd Screw, 5/16-18 x 1-1/2 in.	3
71	Lock Washer, 5/16 in.	3
72	Hex Nut, 5/16-18	3

REF NO.	DESCRIPTION	QTY
73	Dowel Pin, 8mm x 20mm	2
76	Drive Shaft	1
77	Soc Hd Screw, M8 – 1.25 x 25mm	5
78	Lock Washer, 8mm	5
79	Coupling	1
103	Engine Adapter Bushing (After April 18, 2001)	1

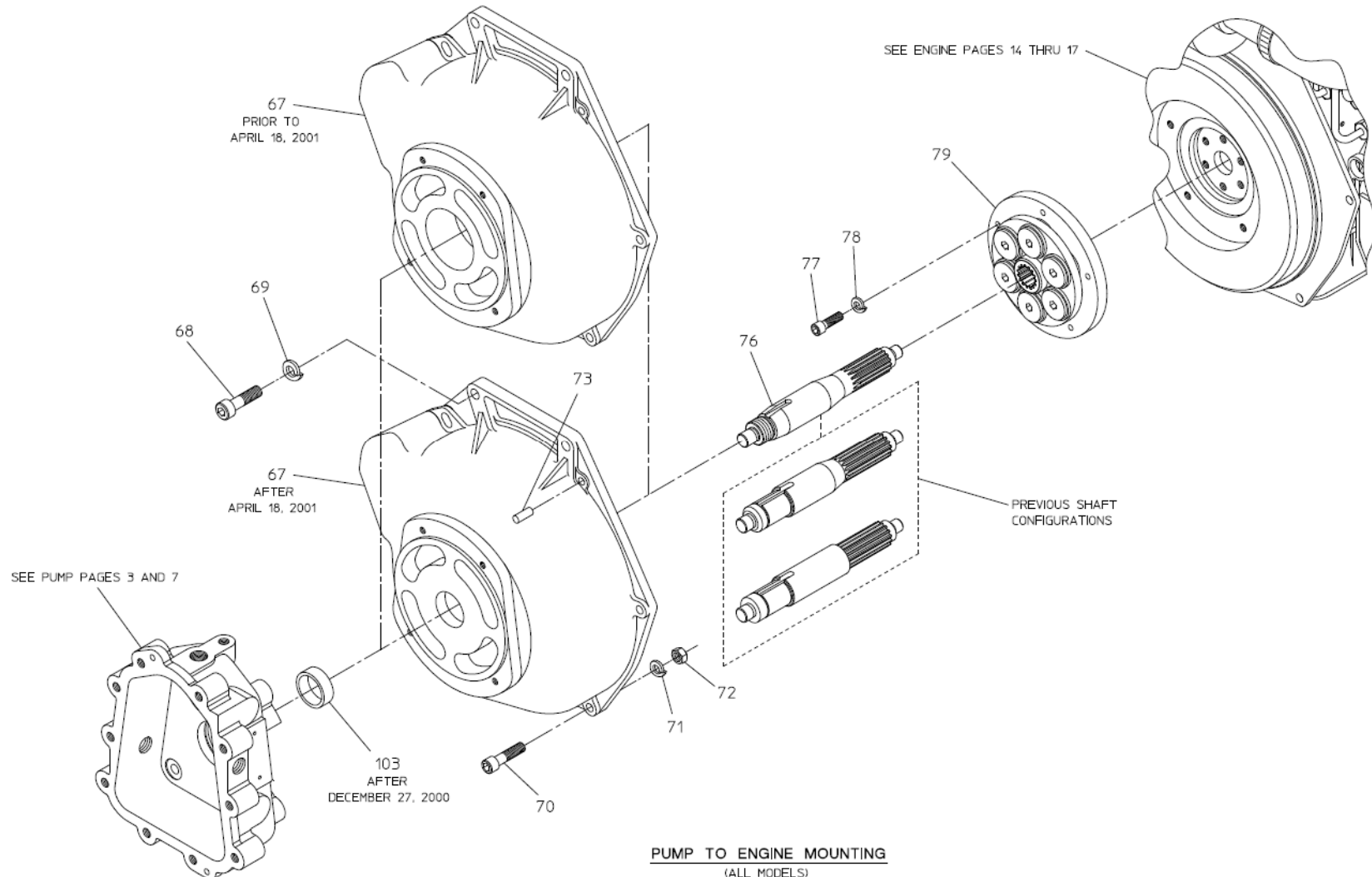

**PUMP TO ENGINE MOUNTING**  
 (ALL MODELS)  
 SEE PAGES 5 AND 9 FOR SECTIONAL VIEW

## Pump Discharge Positions

REF NO.	DESCRIPTION	QTY
24	Pipe Plug, 1/4 in. NPT	4
34	Drain Cock	1
43	Magnetic Pipe Plug, 3/8 in., NPT	1
54	Pipe Plug, 3/8 in. NPT	5 or 6

REF NO.	DESCRIPTION	QTY
62	90 Deg. Pipe Elbow, 3/8 in. NPT (Prior to May 19, 2005)	1
63	Pipe Nipple, 3/8 in. NPT x 3 in. (Prior to May 19, 2005)	1
64	Breather	1
106	Headless Pipe Plug, 1/8 NPT	1

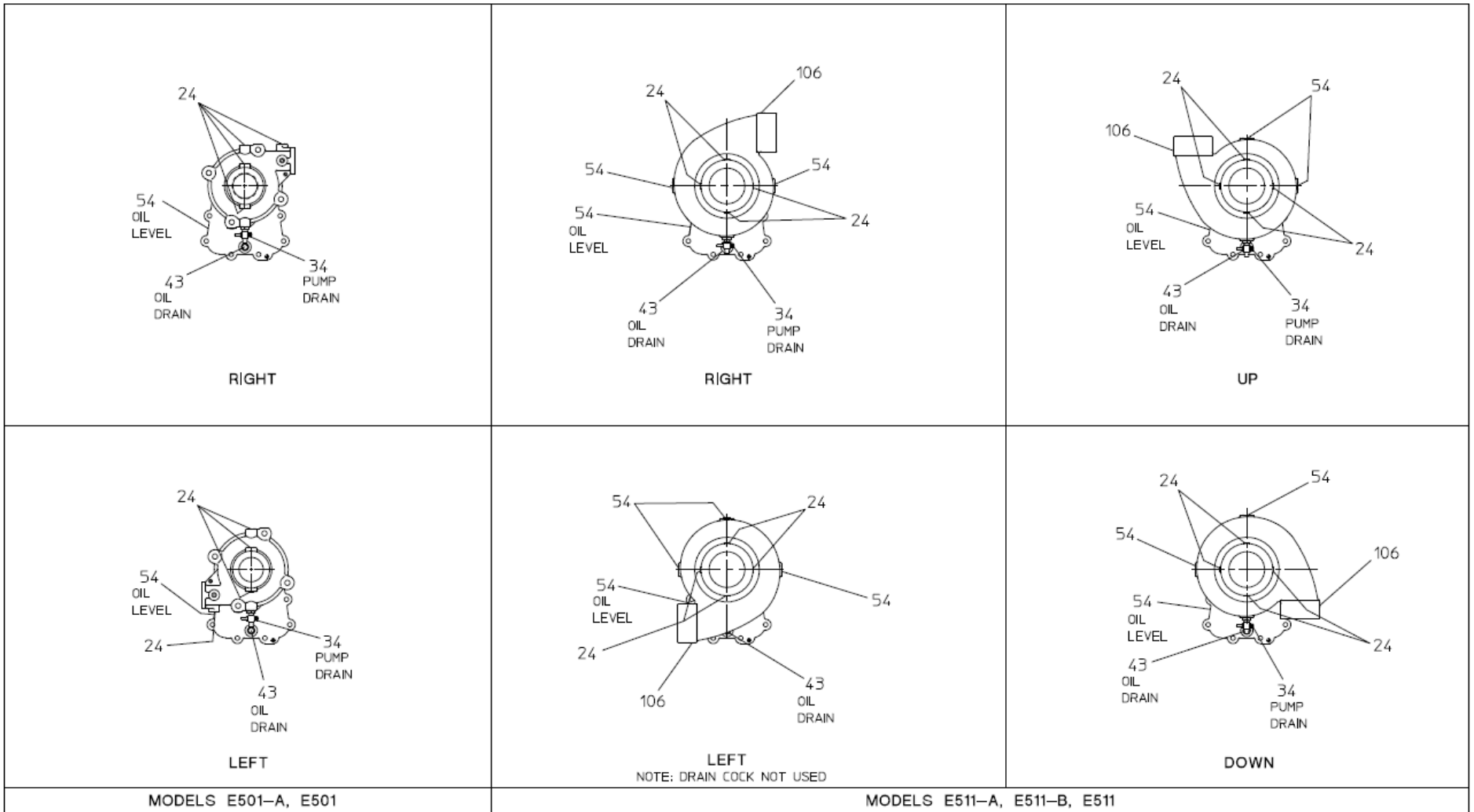

PUMP DISCHARGE POSITIONS

## Diesel Engine, Models E501-A & E511-A

REF NO.	DESCRIPTION	QTY
78	Lock Washer, 8mm	4
81	Muffler Kit (Includes 142 & 143)	1
82	Rain Cap	1
83	Diesel Engine, DM950D	1
84	Oil Pressure Bracket Spacer	2
85	Oil Pressure Sender Hose Kit (Deluxe Panel Only)	1
86	Fuel Line, 11-1/2 in.	1
87	Hose Clamp	2
88	Fuel Filter	1
89	Soc Hd Screw, M8 – 1.25 x 65mm	2

REF NO.	DESCRIPTION	QTY
91	Oil Pressure Sender (Deluxe Panel Only)	1
92	Grommet (Deluxe Panel Only)	1
93	Oil Pressure Sender Bracket	1
94	Soc Hd Screw, M8 – 1.25 x 16mm	2
95	Swivel Assembly	1
96	Temperature Sender (Deluxe Panel Only)	1
139	Panel Serial Plate (Optional)	1
140	Spark Arrestor (Optional)	1
141	Self Tapping Screw, #8 x 1/2 in.	1
142	Muffler Gasket	1
143	Hex Nut (Muffler Mounting)	4

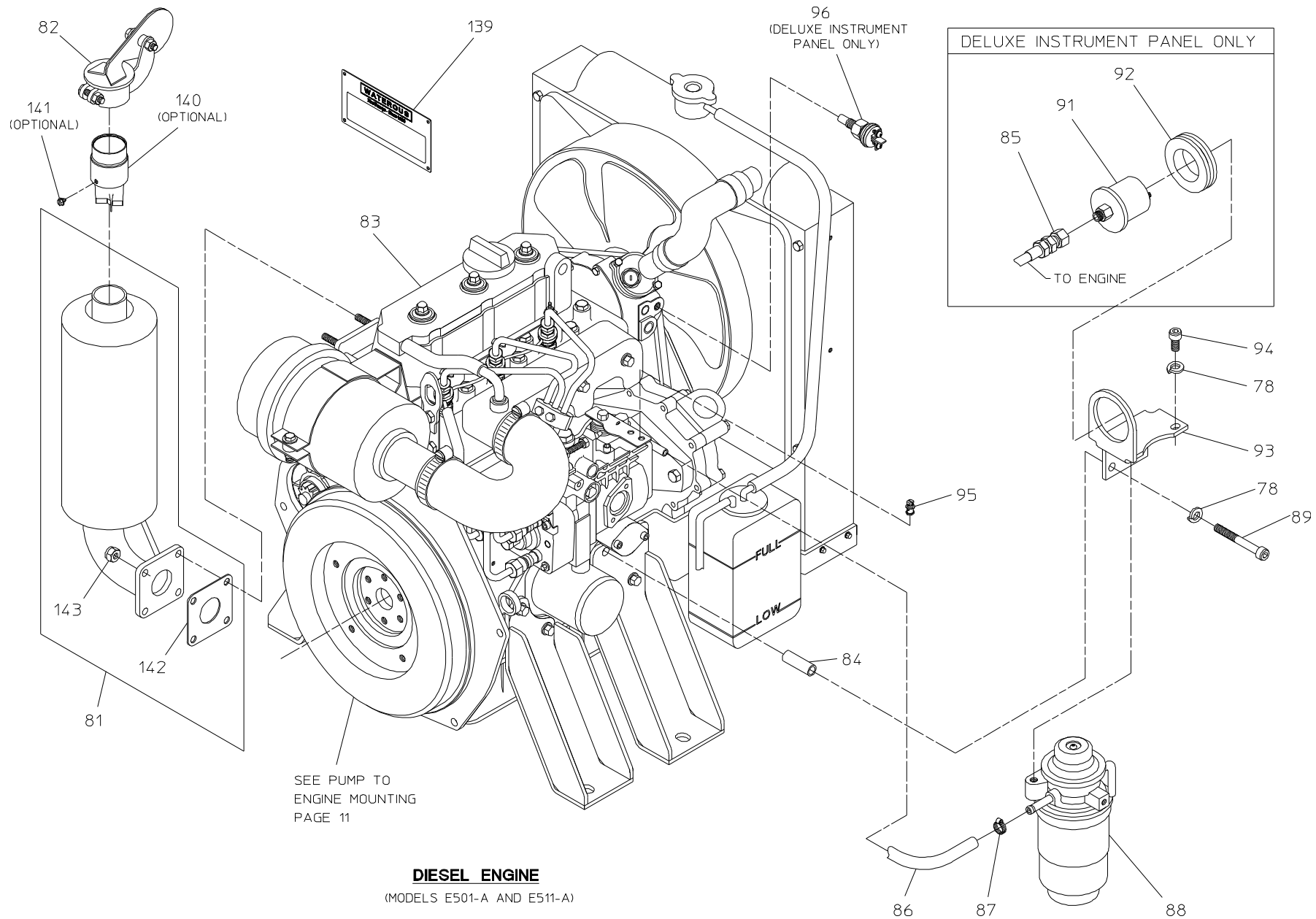

## Gasoline Engine, Model E511-B

REF NO.	DESCRIPTION	QTY
35	Soc Hd Screw, 1/4-20 x 3/4 in.	1
36	Flat Washer, 1/4 in.	1
37	Nylok Nut, 1/4-20	1
74	Fuel Pump	1
75	Fuel Line, 4-3/4 in.	1
78	Lock Washer, 8mm	2
81	Muffler Kit (Includes 142 & 143)	1
82	Rain Cap	1
83	Diesel Engine, DM950G	1
84	Spacer	2
86	Fuel Line, 10-1/2 in.	1

REF NO.	DESCRIPTION	QTY
87	Hose Clamp	2
88	Fuel Filter	1
89	Soc Hd Screw, M8 – 1.25 x 65mm	2
116	Soc Hd Screw, 5/16-18 x 3/4 in.	1
117	Flat Washer, 5/16 in.	1
118	Nylok Nut, 5/16-18	1
119	Fuel Pump Bracket	1
142	Muffler Gasket	1
143	Hex Nut (Muffler Mounting)	4



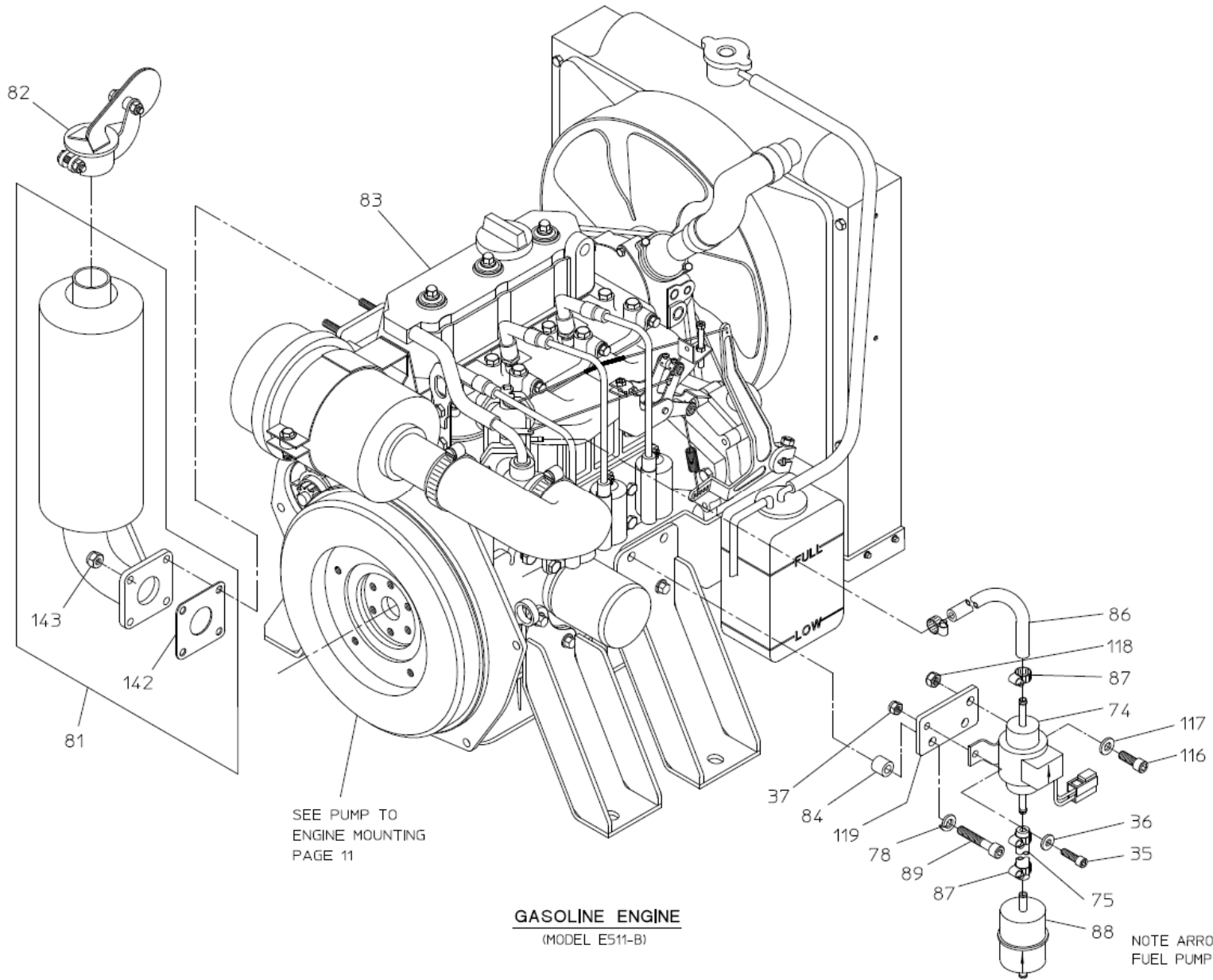

**Single Municipal Panel Connection to Engine  
Diesel Engine Models E501-A & 511-A**

<b>REF NO.</b>	<b>DESCRIPTION</b>	<b>QTY</b>
19	Throttle Control	1
97	Engine Wiring Harness	1
98	Connector Bracket	1

<b>REF NO.</b>	<b>DESCRIPTION</b>	<b>QTY</b>
99	Lock Washer, 6mm	2
100	Hex Hd Screw, M6 – 1.0 x 12mm	2
107	Panel Serial Plate (Optional)	1

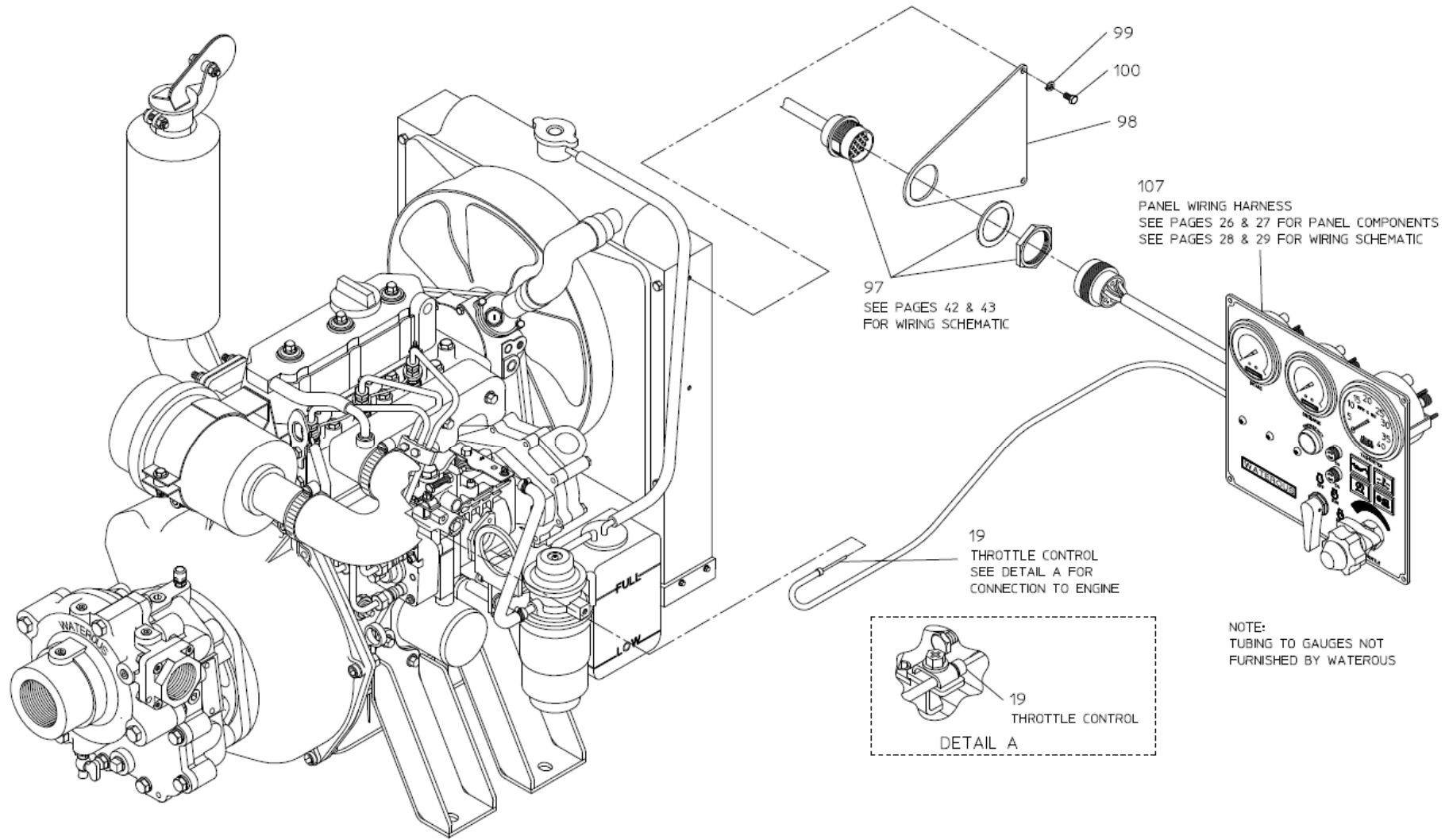

SINGLE MUNICIPAL PANEL CONNECTION TO ENGINE  
DIESEL ENGINE, MODELS E501-A AND E511-A

**Dual Municipal Panel Connection to Engine  
Diesel Engine, Models E501-A & E511-A**

<b>REF NO.</b>	<b>DESCRIPTION</b>	<b>QTY</b>
19	Throttle Control	1
97	Engine Wiring Harness	1
98	Connector Bracket	1
99	Lock Washer, 6mm	2

<b>REF NO.</b>	<b>DESCRIPTION</b>	<b>QTY</b>
100	Hex Hd Screw, M6 – 1.0 x 12mm	2
101	Panel Wiring Harness, Main Panel	1
135	Panel Wiring Harness, In-Cab Panel	1

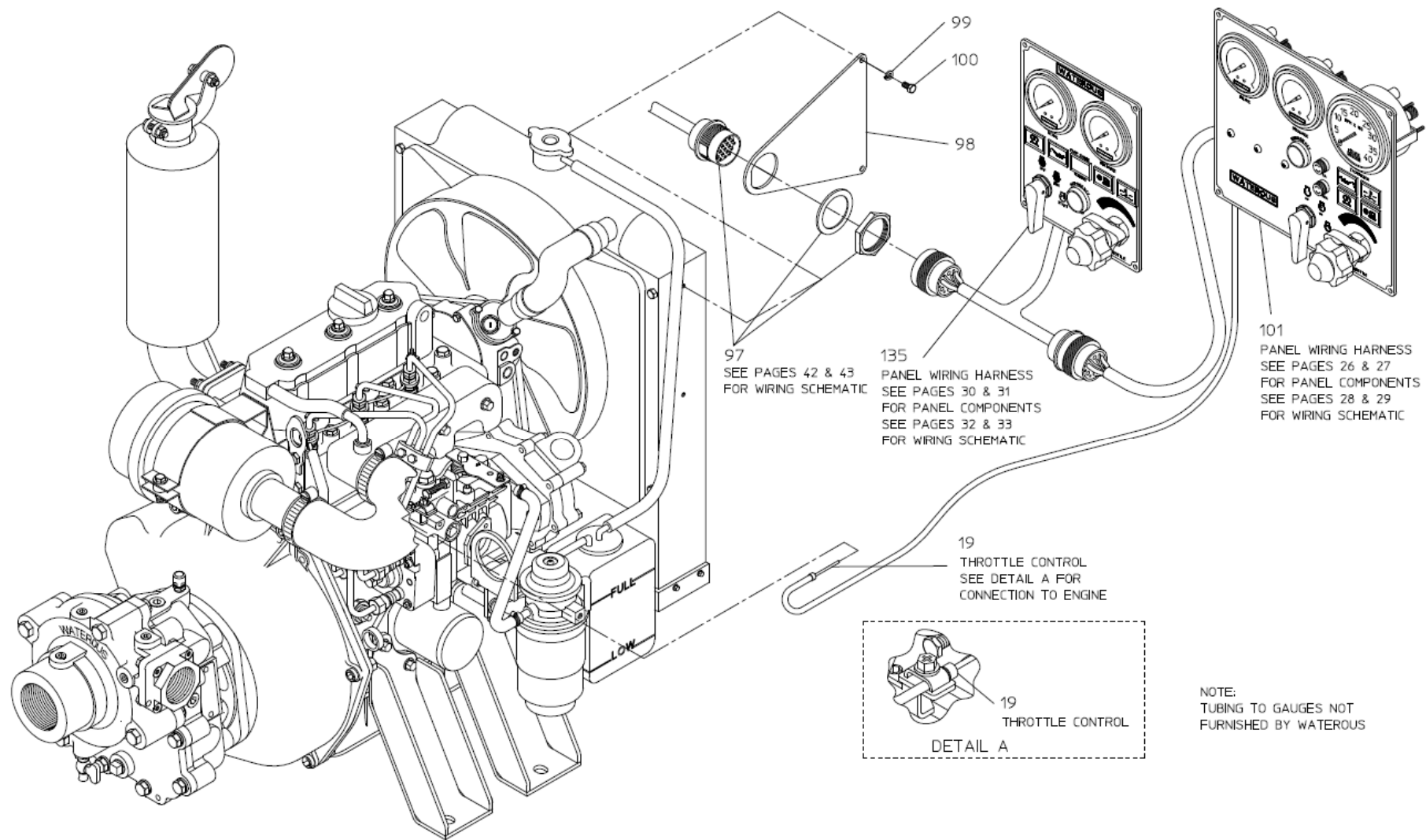

DUAL MUNICIPAL PANEL CONNECTION TO ENGINE

DIESEL ENGINE, MODELS E501-A AND E511-A

NOTE:  
TUBING TO GAUGES NOT  
FURNISHED BY WATEROUS

**Deluxe Panel Connection to Engine**  
**Diesel Engine, Models E501-A & E511-A**

<b>REF NO.</b>	<b>DESCRIPTION</b>	<b>QTY</b>
19	Throttle Control	1
97	Engine Wiring Harness	1
98	Connector Bracket	1

<b>REF NO.</b>	<b>DESCRIPTION</b>	<b>QTY</b>
99	Lock Washer, 6mm	2
100	Hex Hd Screw, M6 – 1.0 x 12mm	2
107	Panel Serial Plate (Optional)	1

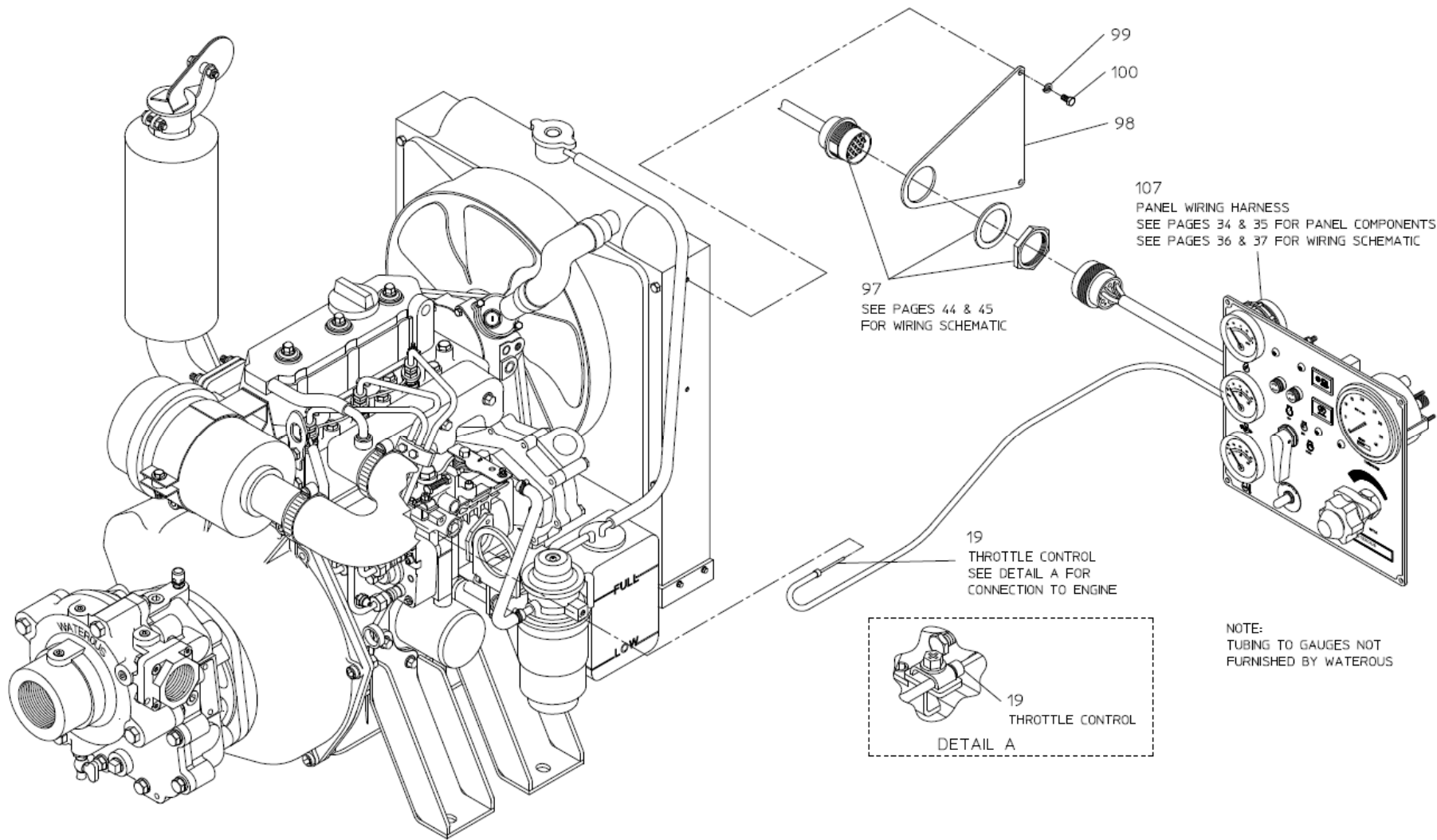

**DELUXE PANEL CONNECTION TO ENGINE**  
 DIESEL ENGINE, MODELS E501-A AND E511-A

**Single Municipal Panel Connection to Engine  
Gasoline Engine, Model E511-B**

<b>REF NO.</b>	<b>DESCRIPTION</b>	<b>QTY</b>
19	Throttle Control	1
97	Engine Wiring Harness	1
98	Connector Bracket	1
99	Lock Washer, 6mm	2

<b>REF NO.</b>	<b>DESCRIPTION</b>	<b>QTY</b>
100	Hex Hd Screw, M6 – 1.0 x 12mm	2
101	Panel Wiring Harness, Main Panel	1
112	Choke Control	1



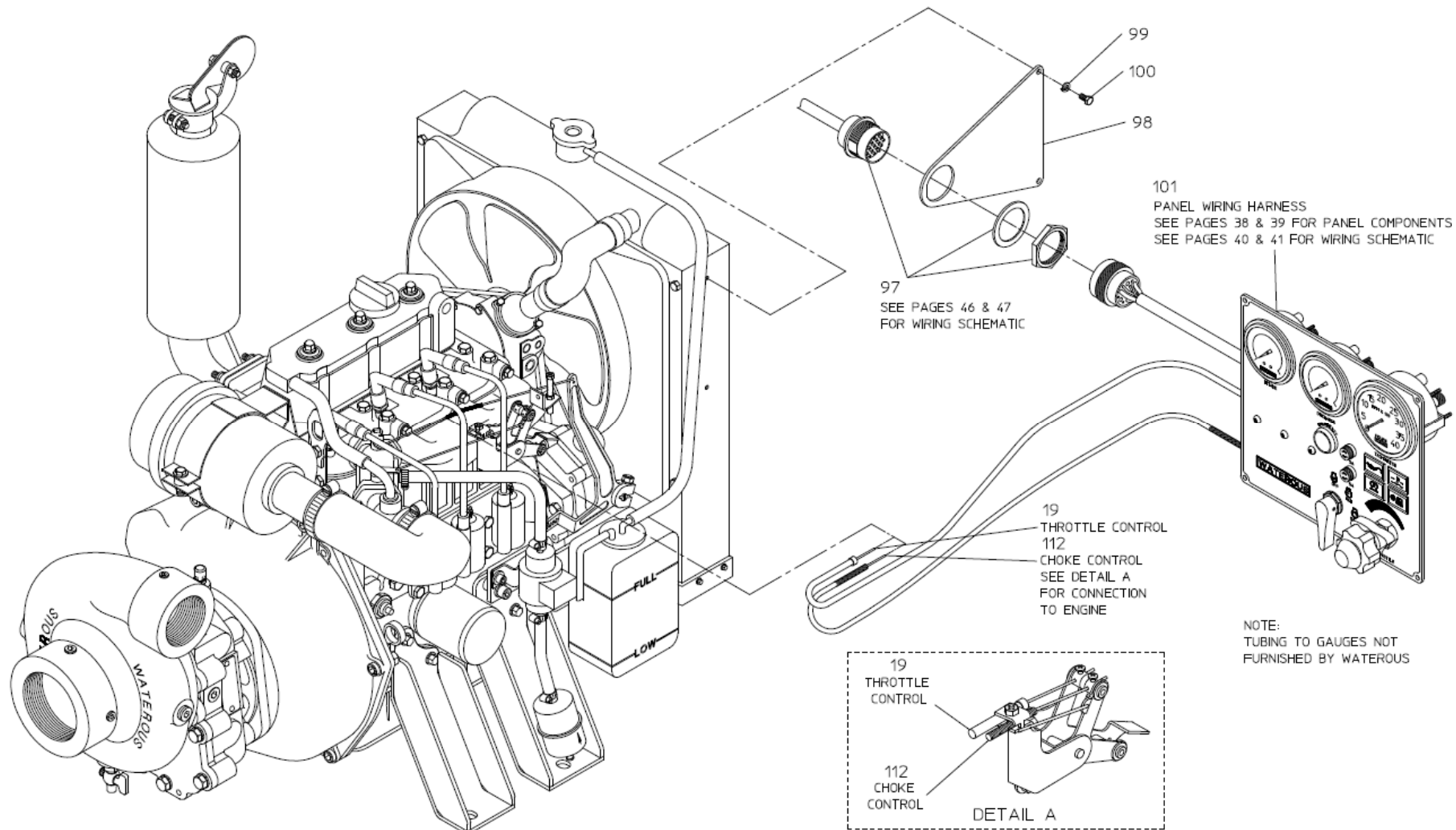

SINGLE MUNICIPAL PANEL CONNECTION TO ENGINE  
GASOLINE ENGINE, MODEL E511-B

**Municipal Panel – Main Panel for Single or Dual Options  
(Diesel Engines, Models E501-A & E511-A)**

REF NO.	DESCRIPTION	QTY
5	5 Amp Fuse	2
6	Fuse Holder	2
7	Pan Head Screw, #10-24 x 1 in.	4
9	Nylok Nut, #10-24	4
11	Switch Knob	1
12	Ignition Switch	1
13	Fuel Filter Lamp	1
14	Glow Lamp	1
15	Pre Heat Timer	1
16	Glow Relay	1
17	Panel Plate	1
18	Panel, Wiring Harness	1

REF NO.	DESCRIPTION	QTY
19	Throttle Control	1
20	Hour Meter/Tach	1
101	Instrument Panel Subassembly (Includes 18, 19)	1
108	Temperature Lamp	1
109	Oil Pressure Lamp	1
110	Intake Gauge	1
111	Discharge Gauge	1
113	Choke Plug	1
128	Relay	1
129	Switch/Contact Block	1

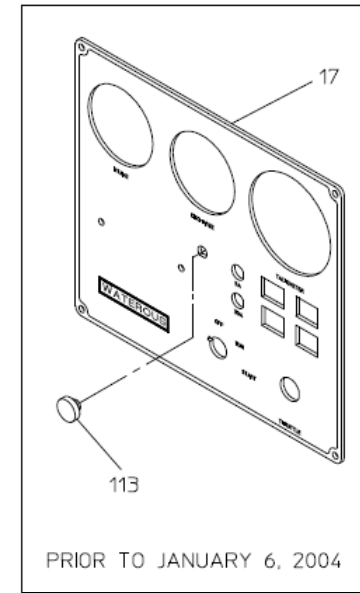
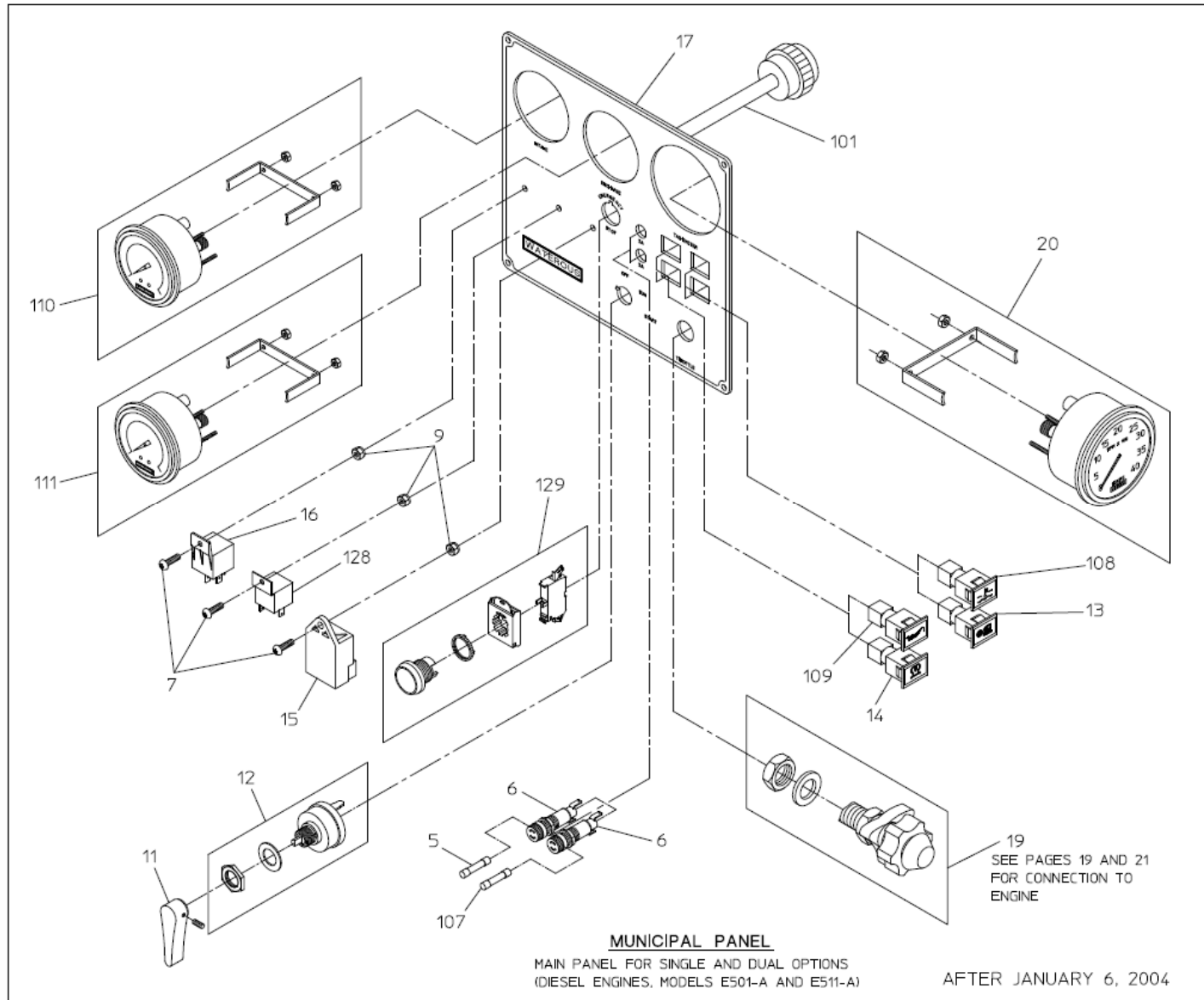

**Wiring Schematic  
Municipal Panel  
Main Panel for Single and Dual Options  
(Diesel Engines, Models E501-A & E511-A)**

<b>REF NO.</b>	<b>DESCRIPTION</b>	<b>QTY</b>
18	Instrument Panel Wiring Harness (Prior to May 4, 2004)	1

<b>REF NO.</b>	<b>DESCRIPTION</b>	<b>QTY</b>
132	Instrument Panel Wiring Harness (After May 4, 2004)	1

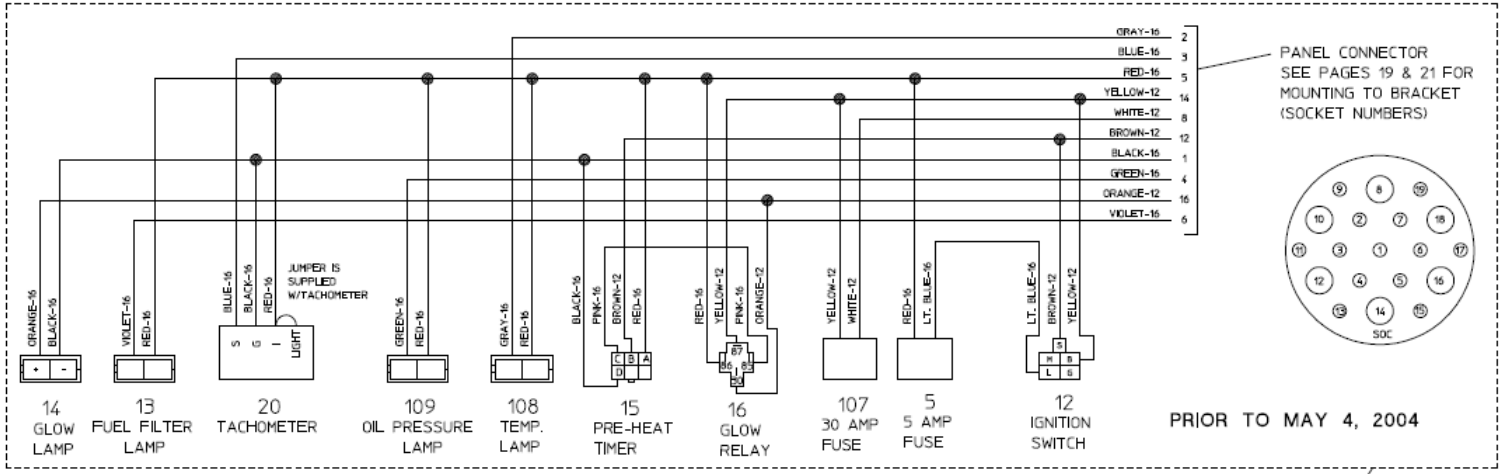
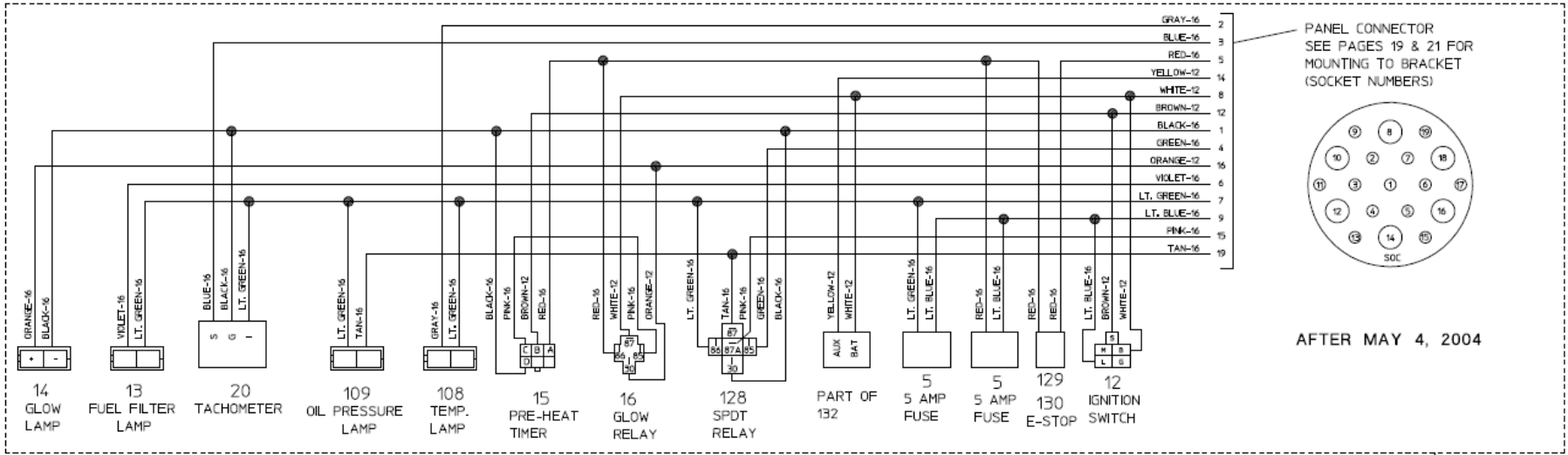

**WIRING SCHEMATIC**

MUNICIPAL PANEL  
MAIN PANEL FOR SINGLE AND DUAL OPTIONS  
(DIESEL ENGINES, MODELS E501-A AND E511-A)  
(APPLIES ONLY IF WATEROUS SUPPLIES INSTRUMENT PANEL)

18

**In-Cab Panel**  
**Furnished with Dual Municipal Panel Option**  
**(Diesel Engines, Models E501-A & E511-A)**

REF NO.	DESCRIPTION	QTY
11	Switch Knob	1
12	Ignition Switch	1
13	Fuel Filter Lamp	1
14	Glow Lamp	1
108	Temperature Lamp	1
109	Oil Pressure Lamp	1
110	Intake Gauge	1

REF NO.	DESCRIPTION	QTY
111	Discharge Gauge	1
127	Engine Run Lamp	1
129	Switch/Contact Block	1
131	Throttle	1
133	Panel	1
134	In-Cab Panel Wiring Harness	1
135	In-Cab Instrument Panel Subassembly	1

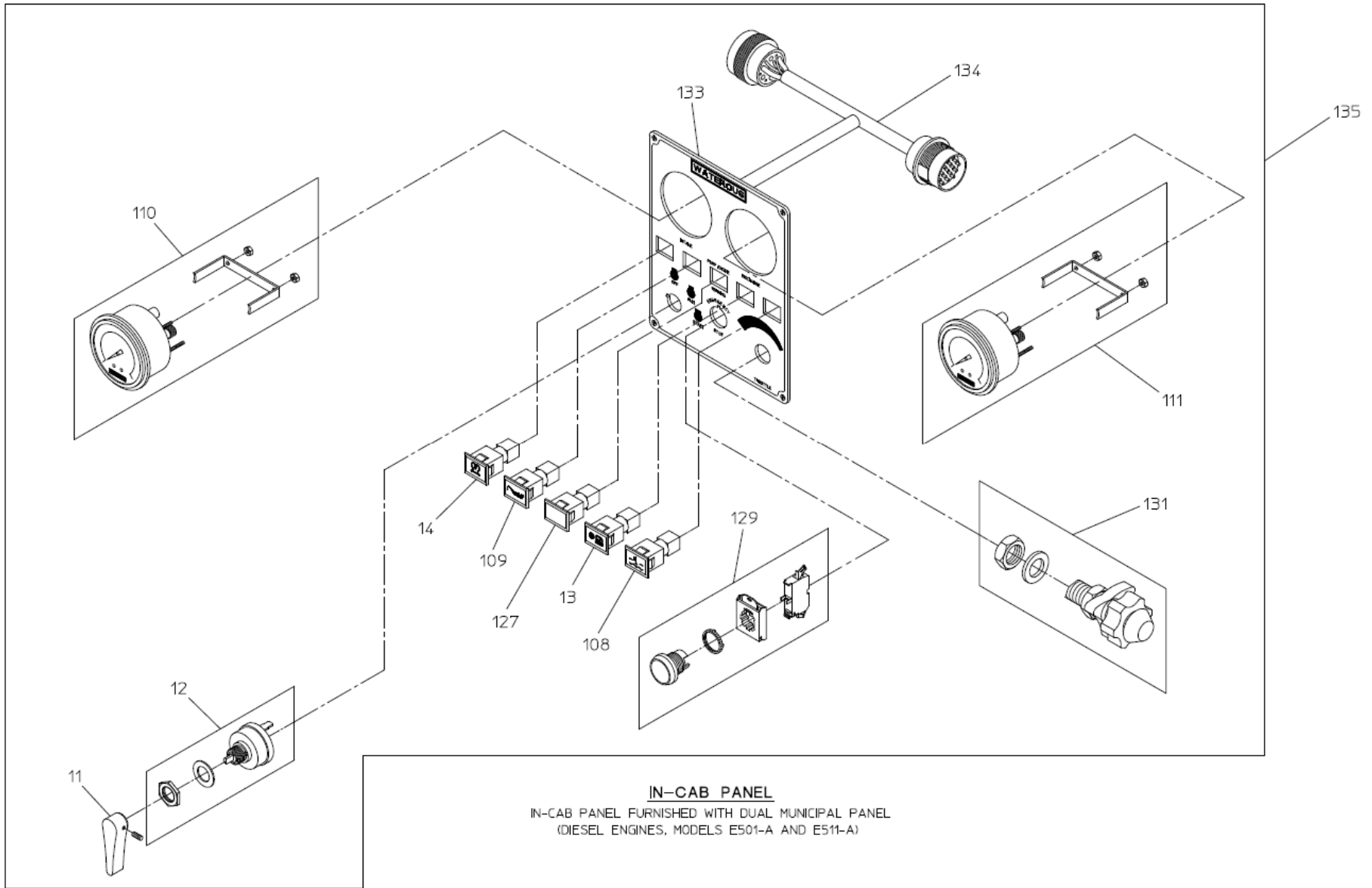

**Wiring Schematic**  
**In-Cab Panel Furnished with Dual Municipal Panel**  
**(Diesel Engines, Models E501-A & E511-A)**

REF NO.	DESCRIPTION	QTY
134	In-Cab Panel Wiring Harness	1

REF NO.	DESCRIPTION	QTY



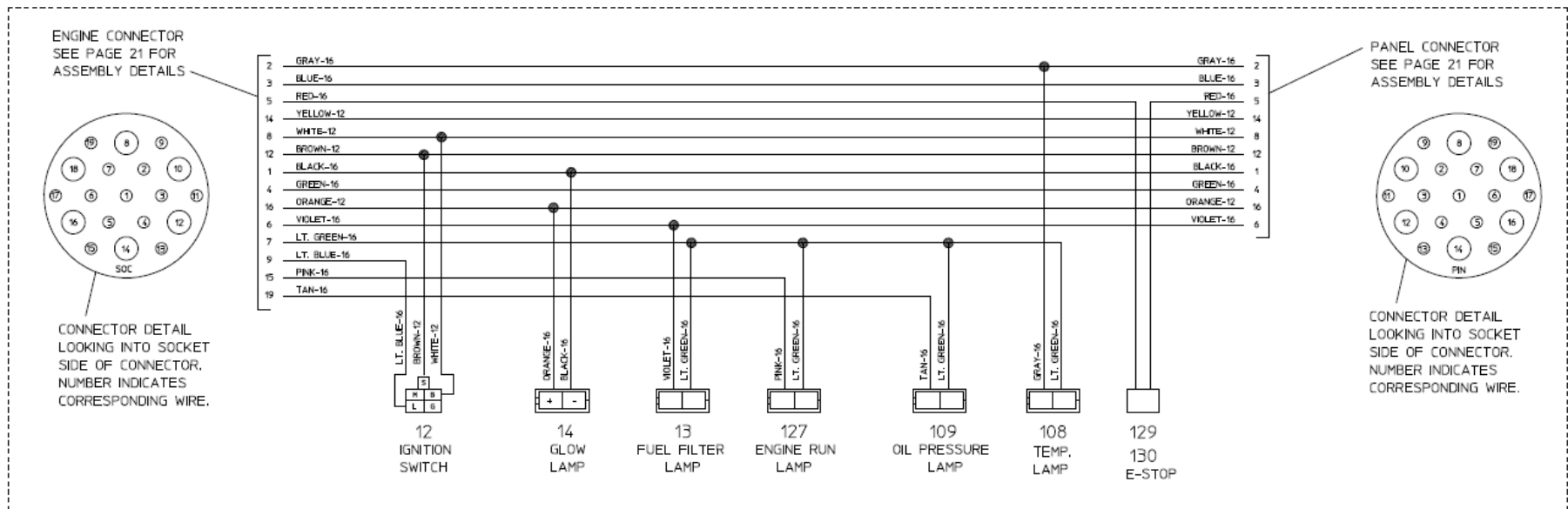

134

WIRING SCHEMATIC

IN-CAB PANEL FURNISHED WITH DUAL MUNICIPAL PANEL  
(DIESEL ENGINES, MODELS E501-A AND E511-A)  
(APPLIES ONLY IF WATEROUS SUPPLIES INSTRUMENT PANEL)

## Deluxe Panel (Diesel Engines, Models E501-A & E511-A)

REF NO.	DESCRIPTION	QTY
1	Ammeter	1
2	Oil Pressure Gauge	1
3	Temperature Gauge	1
4	15 Amp Fuse	1
5	5 Amp Fuse	1
6	Fuse Holder	2
7	Pan Head Screw, #10-24 x 1 in.	4
9	Nylok Nut, #10-24	4
8	Circuit Breaker	1
9	Nylok Nut, #10-24	4
10	Tattle Tale®	1
11	Switch Knob	1
12	Ignition Switch	1
13	Fuel Filter Lamp	1

REF NO.	DESCRIPTION	QTY
14	Glow Lamp	1
15	Pre Heat Timer	1
16	Glow Relay	1
17	Panel Plate	1
18	Panel, Wiring Harness	1
19	Throttle Control	1
20	Hour Meter/Tach	1
65	Machine Nut, #10-32	2
66	Lock Washer, #10	2
101	Instrument Panel Subassembly (Includes 18, 19)	1

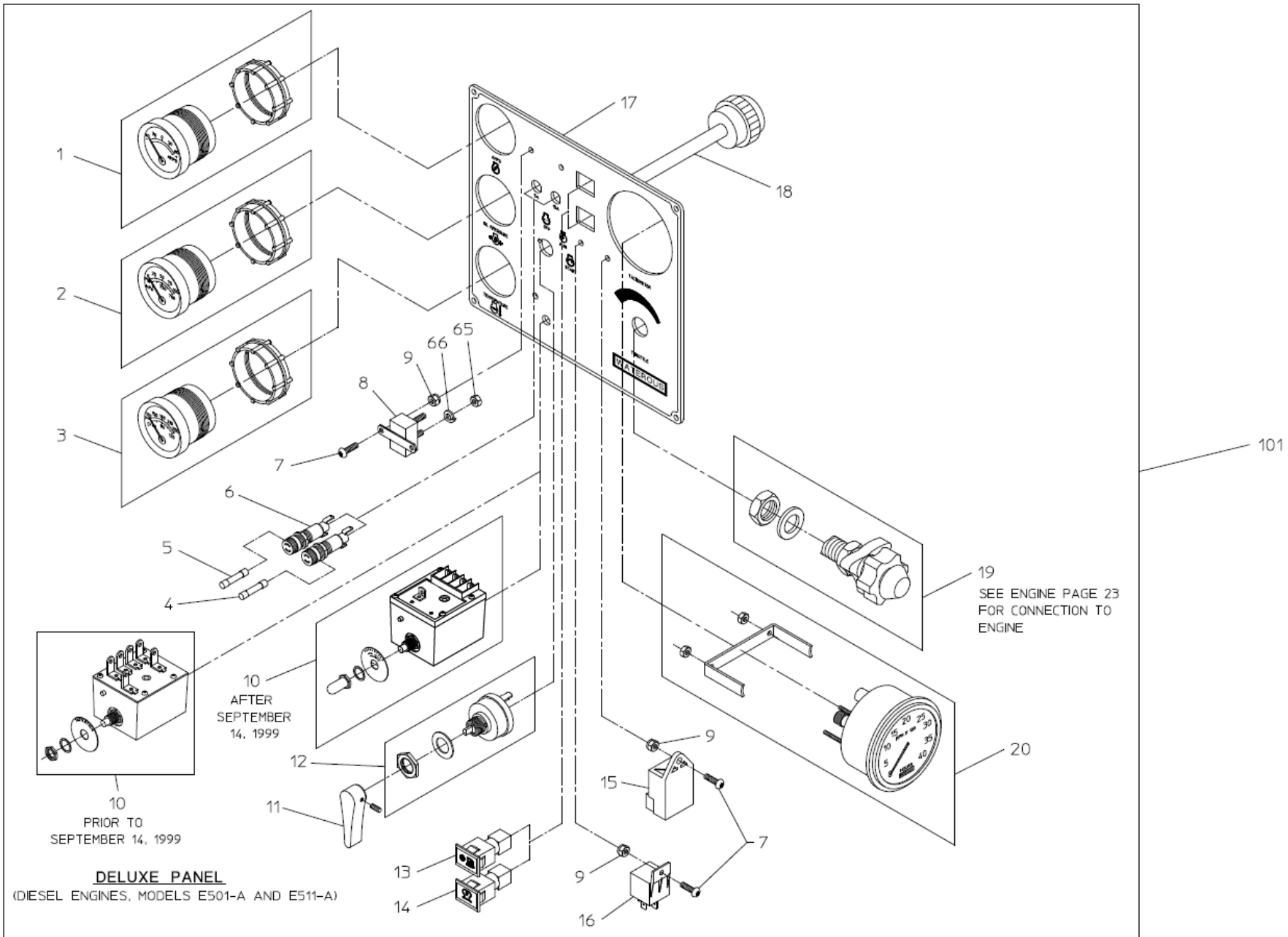

**Wiring Schematic  
Deluxe Panel  
(Diesel Engines, Models E501-A & E511-A)**

<b>REF NO.</b>	<b>DESCRIPTION</b>	<b>QTY</b>
18	Instrument Panel Wiring Harness	1

<b>REF NO.</b>	<b>DESCRIPTION</b>	<b>QTY</b>

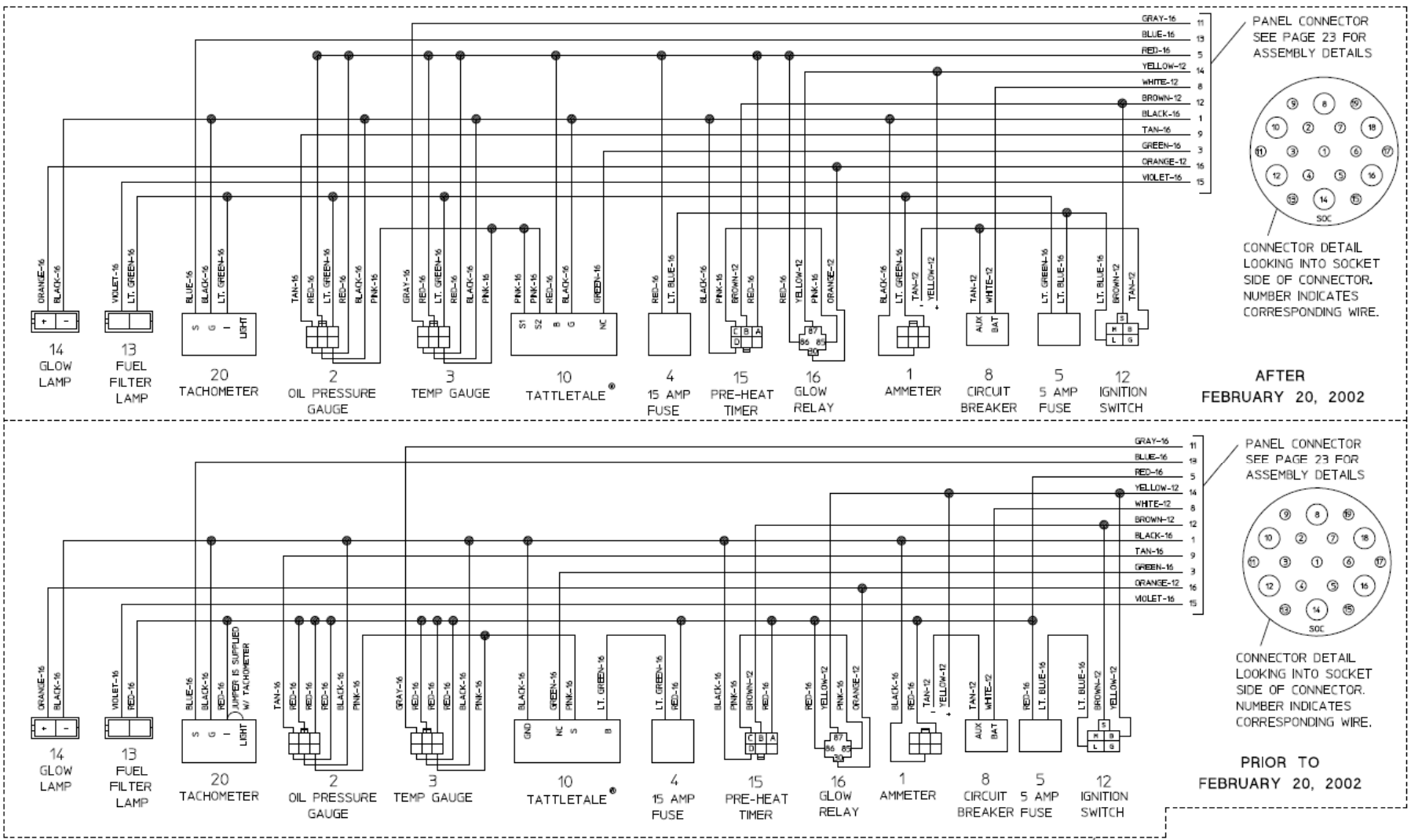

**WIRING SCHEMATIC**

DELUXE PANEL  
(DIESEL ENGINES, MODELS E501-A AND E511-A)  
(APPLIES ONLY IF WATEROUS SUPPLIES INSTRUMENT PANEL)

18

## Municipal Panel (Gasoline Engine, Model E511-B)

REF NO.	DESCRIPTION	QTY
5	5 Amp Fuse	2
6	Fuse Holder	2
7	Pan Head Screw, #10-24 x 1 in.	4
9	Nylok Nut, #10-24	4
11	Switch Knob	1
12	Ignition Switch	1
17	Panel Plate	1
18	Panel, Wiring Harness	1
19	Throttle Control	1
20	Hour Meter/Tach	1
101	Instrument Panel Subassembly (Includes 18, 19)	1

REF NO.	DESCRIPTION	QTY
108	Temperature Lamp	1
109	Oil Pressure Lamp	1
110	Intake Gauge	1
111	Discharge Gauge	1
112	Choke Control	1
114	Lamp Plug	2
120	Ignition Processor	1

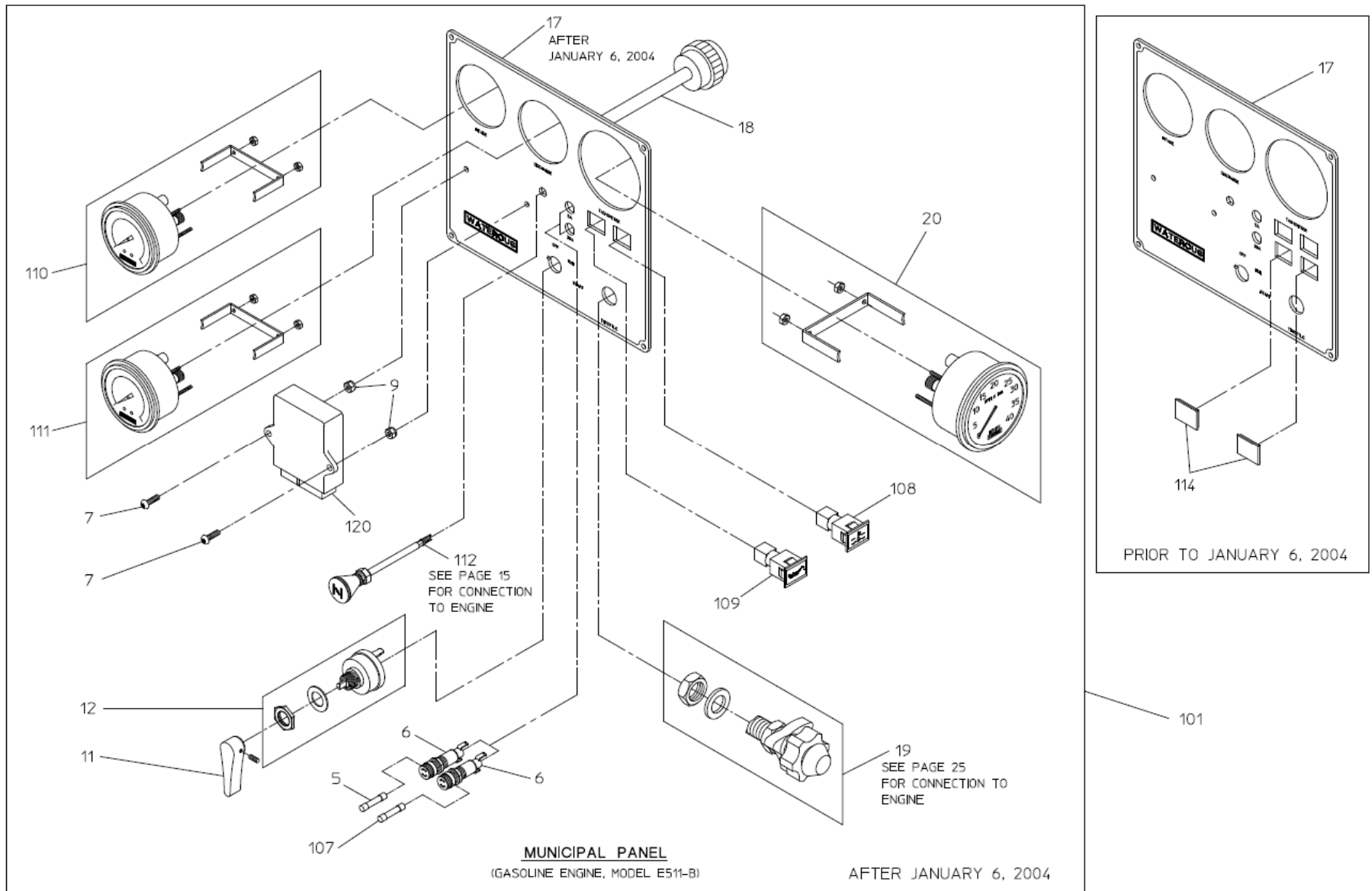

**Wiring Schematic  
Municipal Panel  
(Gasoline Engine, Model E511-B)**

<b>REF NO.</b>	<b>DESCRIPTION</b>	<b>QTY</b>
18	Instrument Panel Wiring Harness	1

<b>REF NO.</b>	<b>DESCRIPTION</b>	<b>QTY</b>



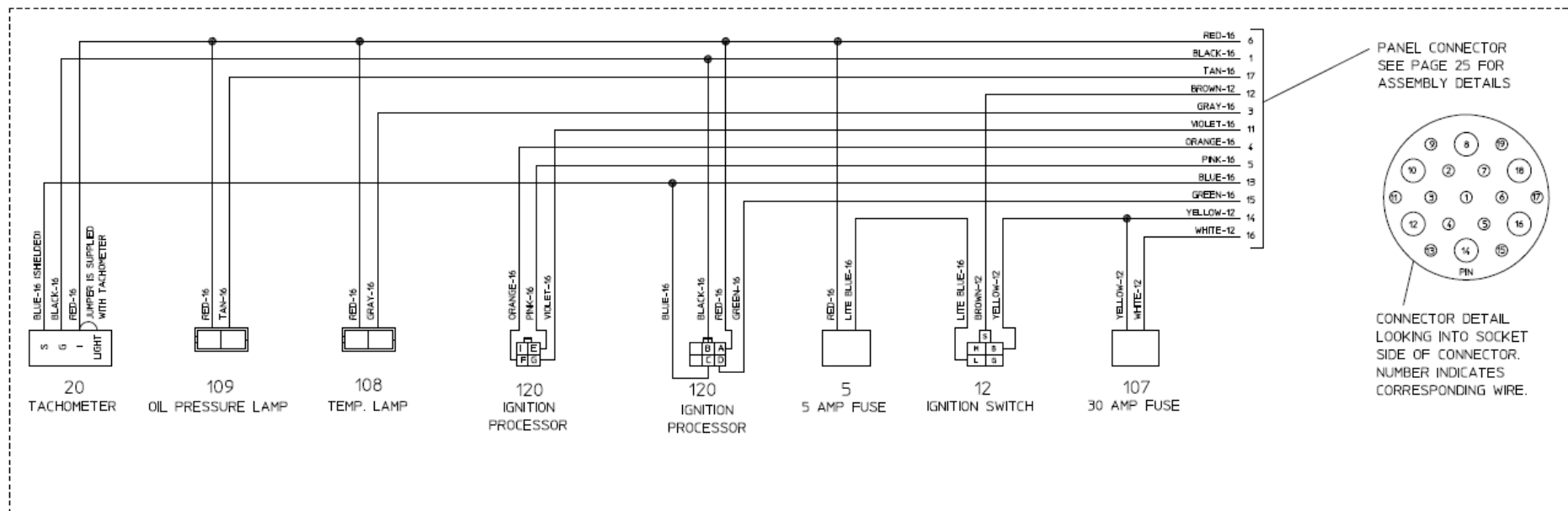

18

**WIRING SCHEMATIC**  
 MUNICIPAL PANEL  
 (GASOLINE ENGINE, MODEL E511-B)  
 (APPLIES ONLY IF WATEROUS SUPPLIES INSTRUMENT PANEL)

**Wiring Schematic**  
**Engine Harness**  
**Single and Dual Municipal Panel**  
**(Diesel Engines, Models E501-A & E511-A)**

REF NO.	DESCRIPTION	QTY
97	Engine Wiring Harness	1

REF NO.	DESCRIPTION	QTY

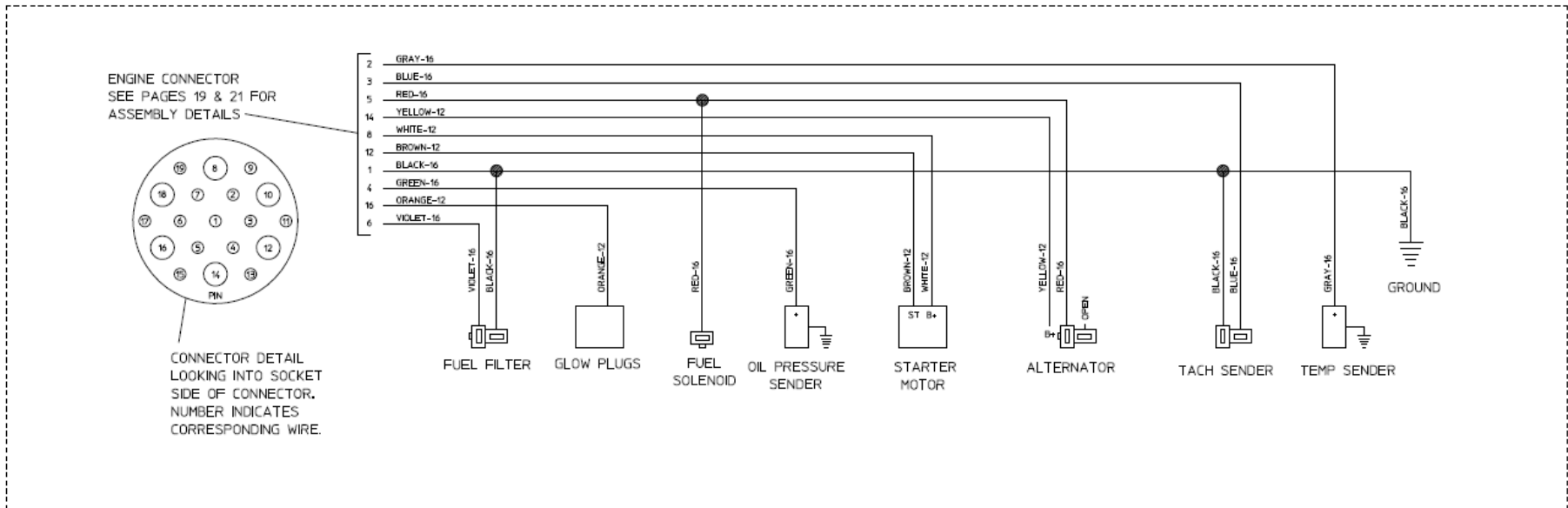

97

WIRING SCHEMATIC

ENGINE HARNESS SINGLE OR DUAL MUNICIPAL PANEL  
(DIESEL ENGINES, MODELS E501-A AND E511-A)  
(APPLIES ONLY IF WATEROUS SUPPLIES INSTRUMENT PANEL)

**Wiring Schematic**  
**Engine Harness**  
**Deluxe Panel**  
**(Diesel Engines, Models E501-A & E511-A)**

REF NO.	DESCRIPTION	QTY
97	Engine Wiring Harness	1

REF NO.	DESCRIPTION	QTY

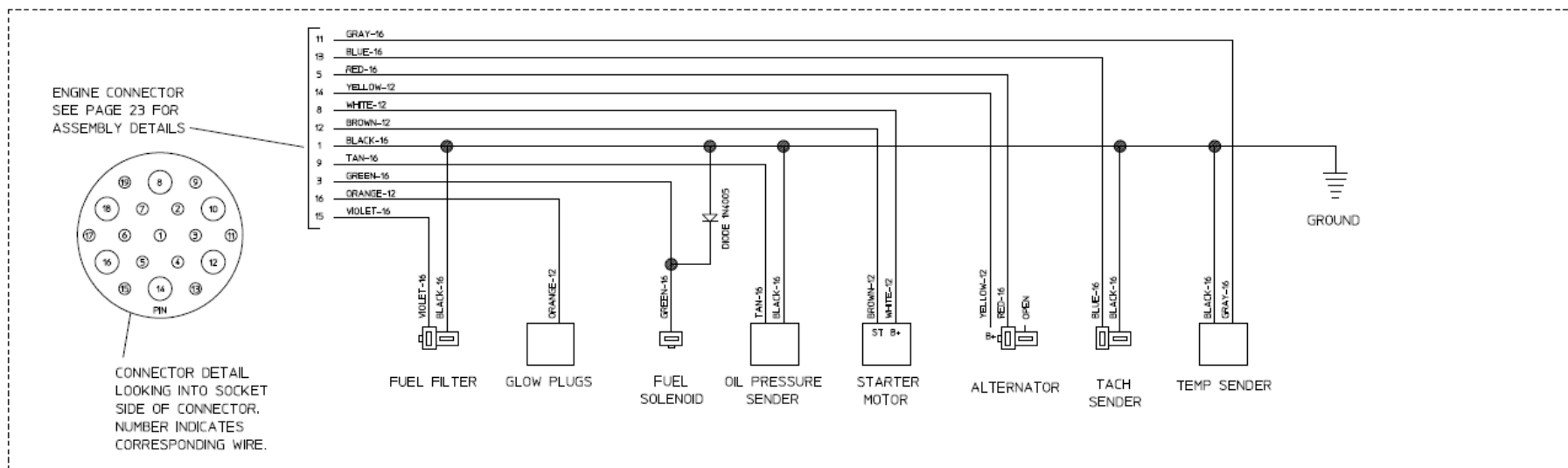

97

**WIRING SCHEMATIC**  
 DELUXE PANEL  
 (DIESEL ENGINES, MODELS E501-A AND E511-A)  
 (APPLIES ONLY IF WATEROUS SUPPLIES INSTRUMENT PANEL)

**Wiring Schematic**  
**Engine Harness**  
**Single Municipal Panel**  
**(Gasoline Engines, Models E511-B)**

<b>REF NO.</b>	<b>DESCRIPTION</b>	<b>QTY</b>
97	Engine Wiring Harness	1

<b>REF NO.</b>	<b>DESCRIPTION</b>	<b>QTY</b>

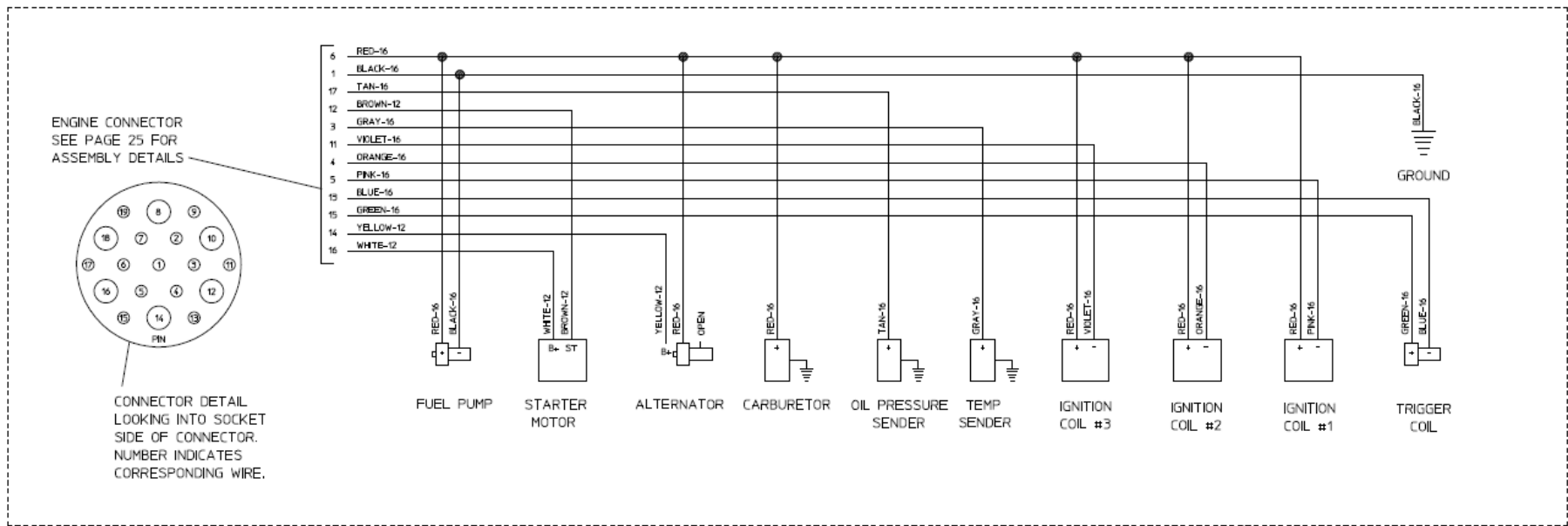

97

**WIRING SCHEMATIC**  
MUNICIPAL PANEL  
(GASOLINE ENGINE, MODEL E511-B)  
(APPLIES ONLY IF WATEROUS SUPPLIES INSTRUMENT PANEL)