

## Transfer Valve Actuator Service Parts List

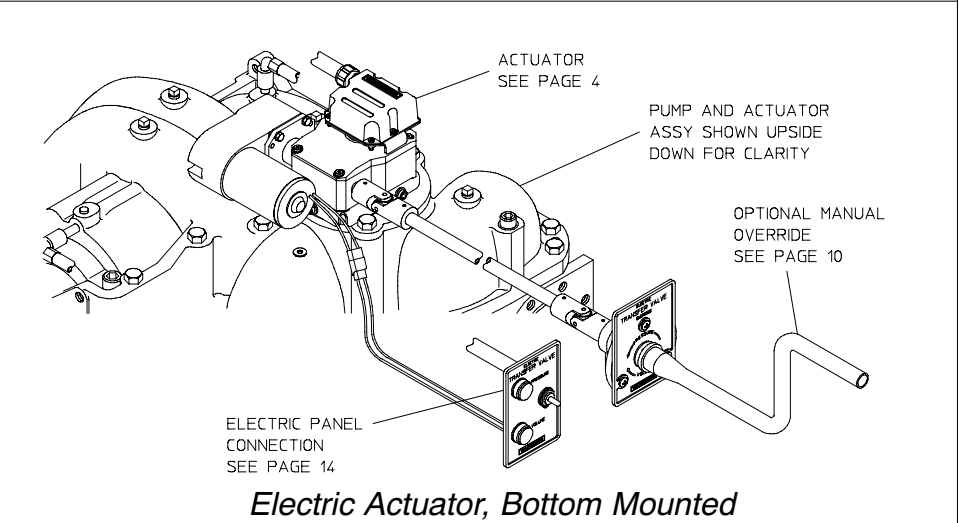
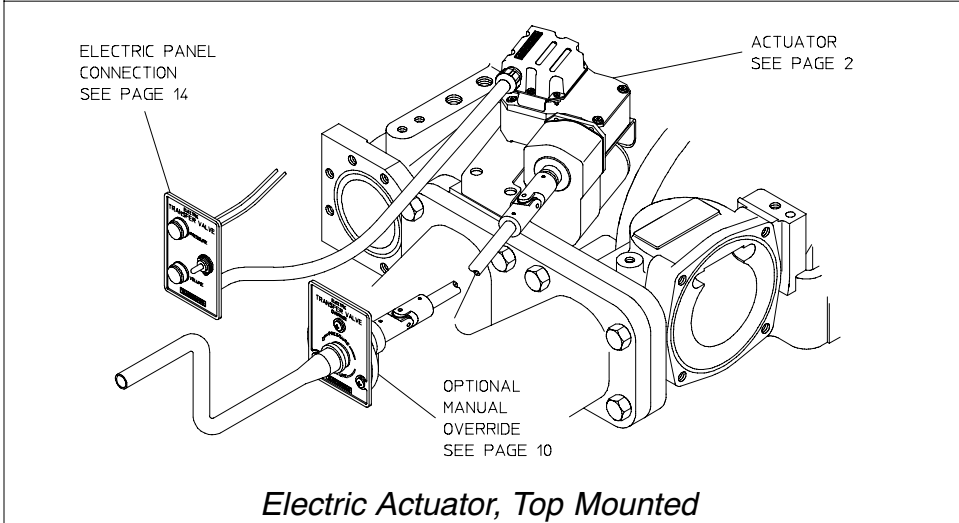
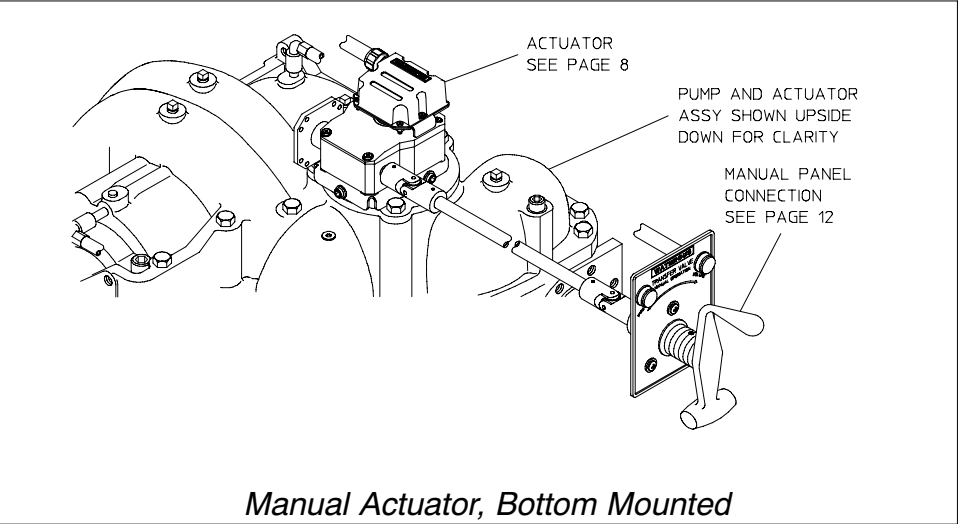
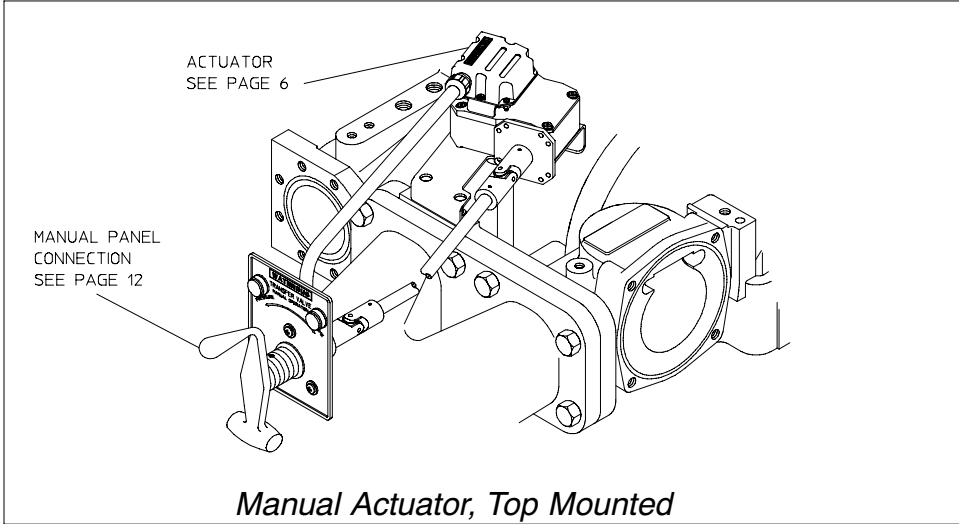

# Table of Contents

- Electric Transfer Valve Actuator (Top Mounted) ..... 1 - 2
- Electric Transfer Valve Actuator (Bottom Mounted) ..... 3 - 4
- Manual Transfer Valve Actuator (Top Mounted) ..... 5 - 6
- Manual Transfer Valve Actuator (Bottom Mounted) ..... 7 - 8
- Manual Override ..... 9 - 10
- Manual Operation ..... 11 - 12
- Electric Panel ..... 13 - 14

## Electric Actuator, Top Mounted

REF. NO.	DESCRIPTION	QTY
1	Worm Gear	1
2	Sector Gear	1
3	Worm Gear Housing	1
4	Housing Cover	1
5	Top Mounting Bracket	1
6	Gear Motor	1
7	Flanged Bearing, 1-1/4 x 1-1/2 in.	2
8	Sleeve Bearing	1
9	O-ring, 1 x 1-1/4 in.	2
10	O-ring, 1/2 x 5/8 in.	1
11	Limit Disk	1
13	Switch Mounting Bracket	1
17	Extension Shaft, Top	1
18	Rubber Plug	2
24	Adapter Nut, 3/4 in.	1
25	Key, 3/16 x 3/4 in.	1
26	Spirol Pin, 1/8 x 3/4 in.	2

REF. NO.	DESCRIPTION	QTY
27	Socket Head Screw, 1/4-20 x 5/8 in.	8
28	Lock Washer, 1/4 in.	8
29	Socket Head Screw, 8-32 x 1/2 in.	8
30	Nylok Nut, 8-32	4
31	Socket Head Screw, 8-32 x 7/8 in.	2
32	Lock Washer, #8	6
33	Hex Head Screw, 3/8-16 x 5/8 in.	1
34	Hex Socket Head Screw, 3/8-16 x 5/8 in.	2
35	Lock Washer, 3/8 in.	3
36	Retaining Ring	1
38	Actuator Wiring Assembly, Electric	1
59	Gear Motor Gasket	1
64	Repair Kit, O-ring/Gasket (Consists of 9, 10, 59, 72 and 73)	0
70	Actuator Subassembly	1
71	Hex Head Screw, 1/4-20 x 5/8 in.	4
72	Switch Cover Gasket	1
73	Actuator Housing Gasket	1
74	Motor Replacement Kit	0

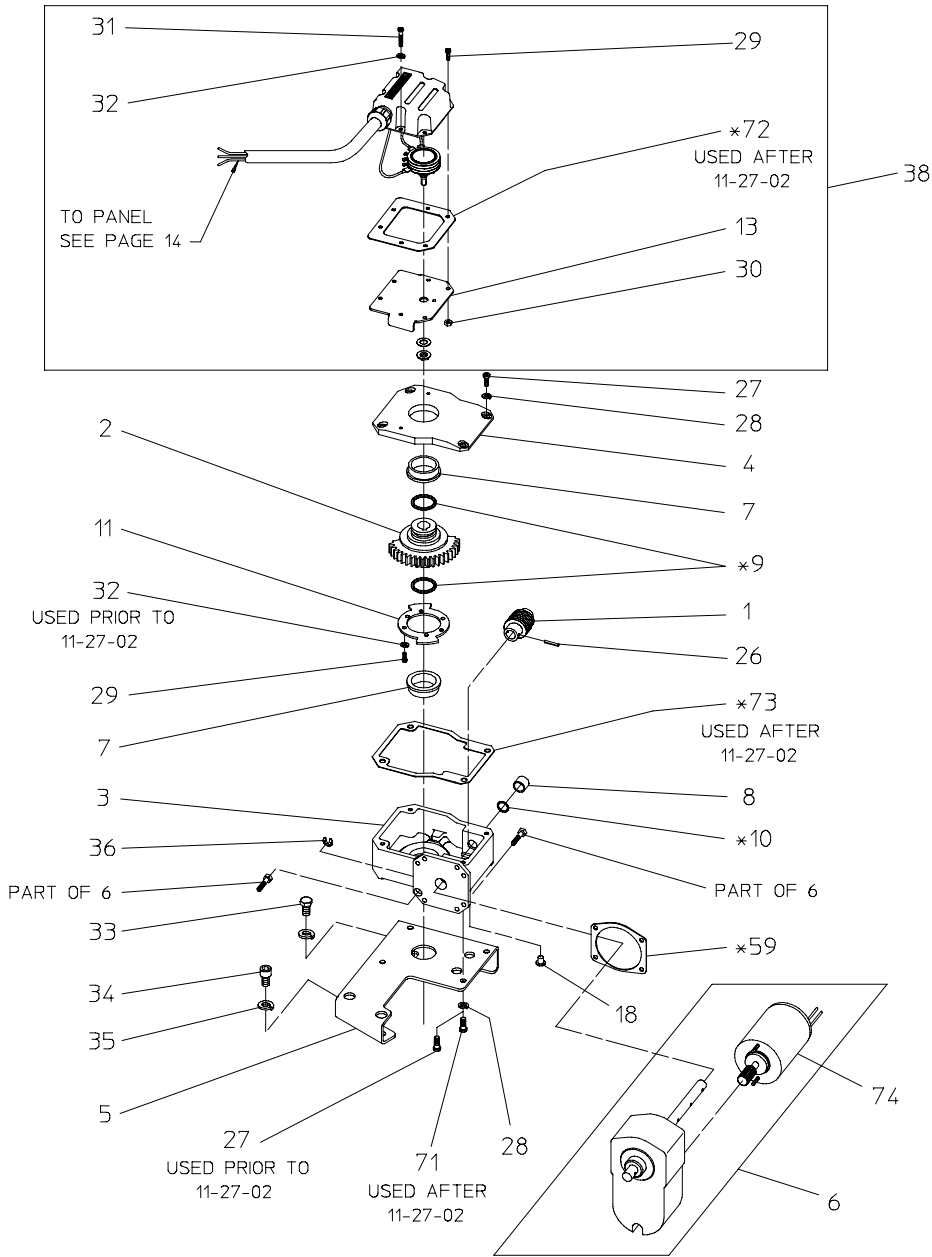

ACTUATOR SUBASSEMBLY REF 70

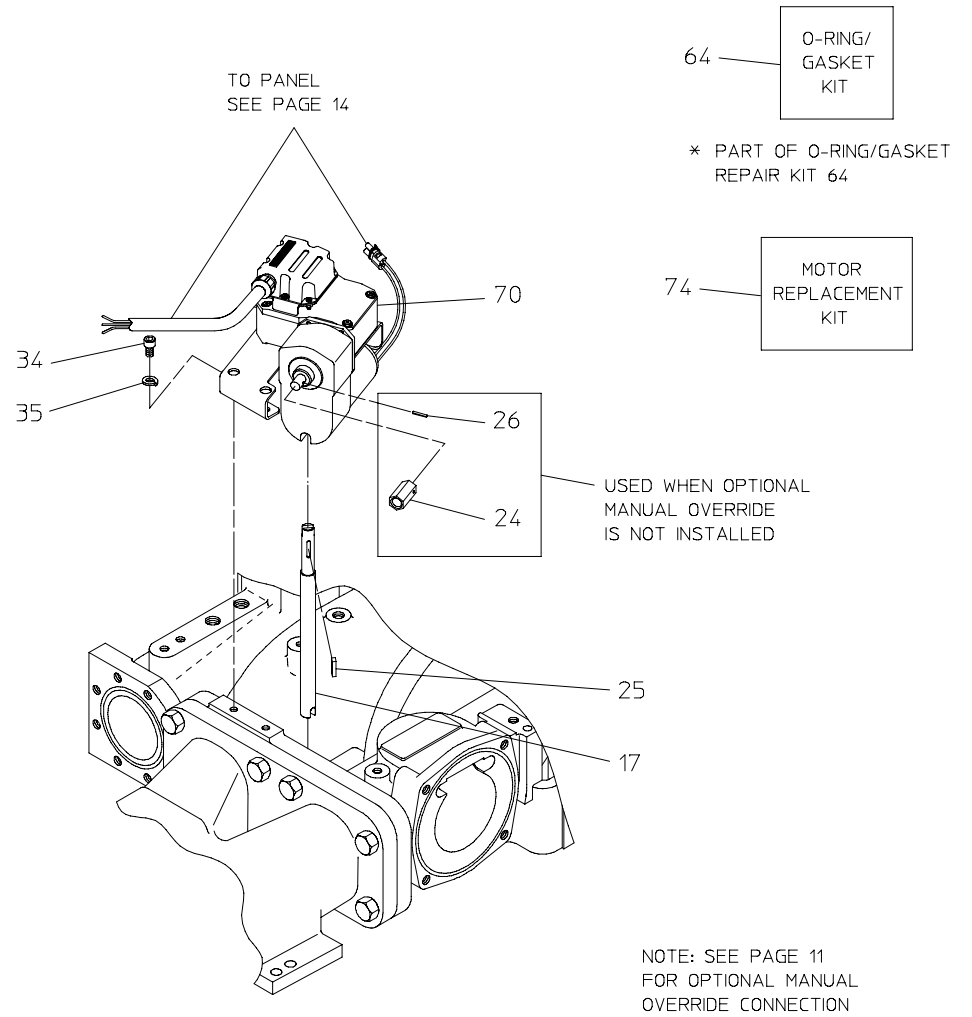

**ELECTRIC ACTUATOR, TOP MOUNTED**

## Electric Actuator, Bottom Mounted

REF. NO.	DESCRIPTION	QTY
1	Worm Gear	1
2	Sector Gear	1
3	Worm Gear Housing	1
4	Housing Cover	1
5	Bottom Mounting Bracket	1
6	Gear Motor	1
7	Flanged Bearing, 1-1/4 x 1-1/2 in.	2
8	Sleeve Bearing	1
9	O-ring, 1 x 1-1/4 in.	2
10	O-ring, 1/2 x 5/8 in.	1
11	Limit Disk	1
13	Switch Mounting Bracket	1
17	Extension Shaft, Bottom	1
18	Rubber Plug	2
24	Adapter Nut, 3/4 in.	1
25	Key, 3/16 x 3/4 in.	1

REF. NO.	DESCRIPTION	QTY
26	Spirol Pin, 1/8 x 3/4 in.	2
27	Socket Head Screw, 1/4-20 x 5/8 in.	8
28	Lock Washer, 1/4 in.	8
29	Socket Head Screw, 8-32 x 1/2 in.	8
30	Nylok Nut, 8-32	4
31	Socket Head Screw, 8-32 x 7/8 in.	2
32	Lock Washer, #8	6
38	Actuator Wiring Assembly, Electric	1
39	Hex Socket Head Screw, 5/16-18 x 9/16 in.	3
40	Lock Washer, 5/16 in.	3
59	Gear Motor Gasket	1
64	Repair Kit, O-ring/Gasket (Consists of 9, 10, 59, 72 and 73)	0
70	Actuator Subassembly	1
71	Hex Head Screw, 1/4-20 x 5/8 in.	4
72	Switch Cover Gasket	1
73	Actuator Housing Gasket	1
74	Motor Replacement Kit	0

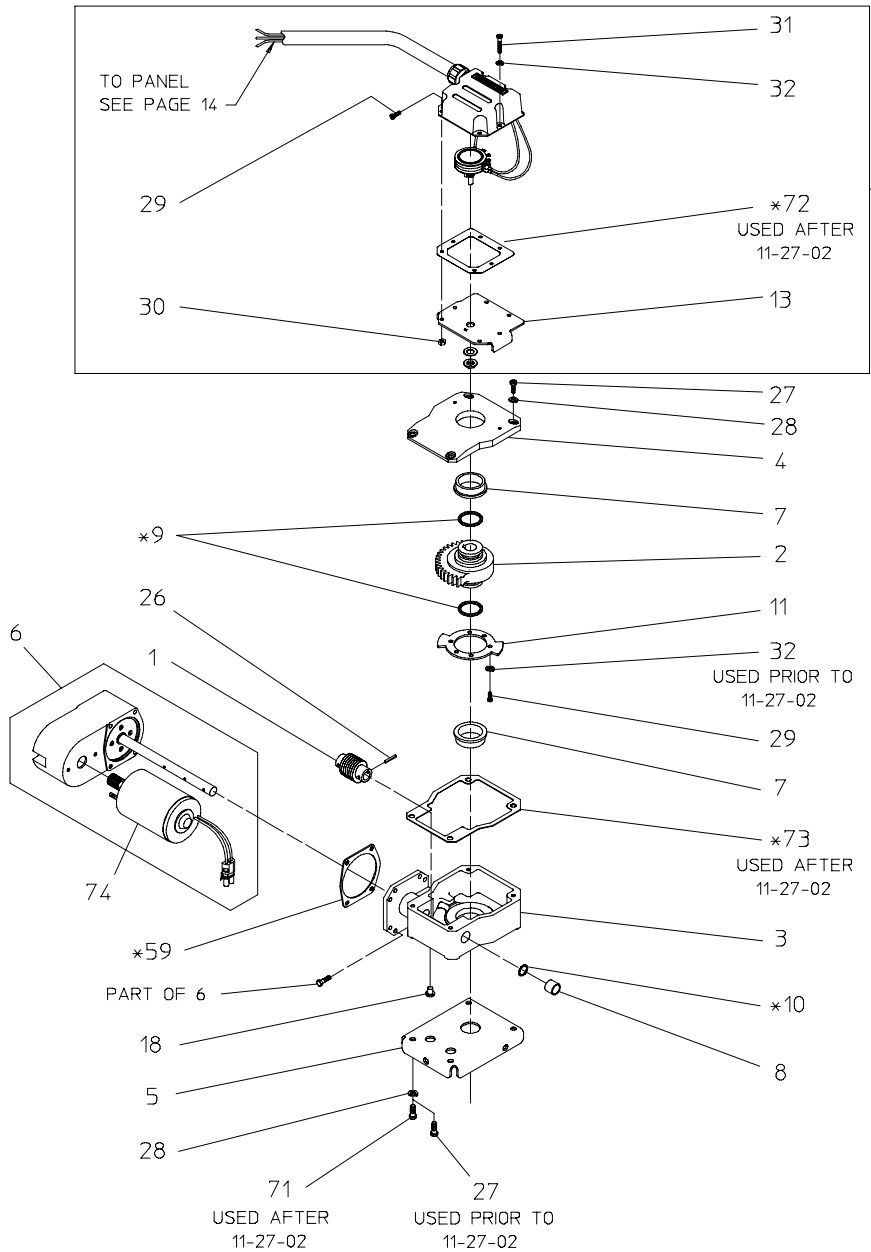

ACTUATOR SUBASSEMBLY REF 70

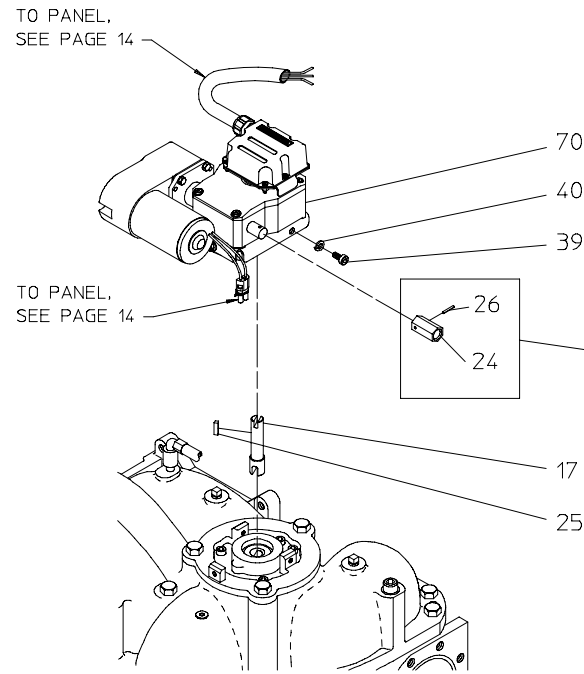

NOTE: PUMP AND ACTUATOR SHOWN UPSIDE DOWN FOR CLARITY

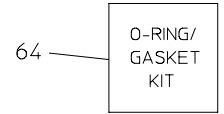

\* PART OF O-RING/GASKET REPAIR KIT 64

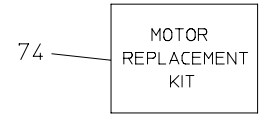

USED WHEN OPTIONAL MANUAL OVERRIDE IS NOT INSTALLED

NOTE: SEE PAGE 11 FOR OPTIONAL MANUAL OVERRIDE CONNECTION

**ELECTRIC ACTUATOR, BOTTOM MOUNTED**

## Manual Actuator, Top Mounted

REF. NO.	DESCRIPTION	QTY
1	Worm Gear	1
2	Sector Gear	1
3	Worm Gear Housing	1
4	Housing Cover	1
5	Top Mounting Bracket	1
7	Flanged Bearing, 1-1/4 x 1-1/2 in.	2
8	Sleeve Bearing	2
9	O-ring, 1 x 1-1/4 in.	2
10	O-ring, 1/2 x 5/8 in.	2
11	Limit Disk	1
13	Switch Mounting Bracket	1
17	Extension Shaft, Top	1
18	Rubber Plug	2
24	Adapter Nut, 3/4 in.	1
25	Key, 3/16 x 3/4 in.	1
26	Spirol Pin, 1/8 x 3/4 in.	2
27	Socket Head Screw, 1/4-20 x 5/8 in.	8

REF. NO.	DESCRIPTION	QTY
28	Lock Washer, 1/4 in.	8
29	Socket Head Screw, 8-32 x 1/2 in.	8
30	Nylok Nut, 8-32	4
31	Socket Head Screw, 8-32 x 7/8 in.	2
32	Lock Washer, #8	6
33	Hex Head Screw, 3/8-16 x 5/8 in.	1
34	Hex Socket Head Screw, 3/8-16 x 5/8 in.	2
35	Lock Washer, 3/8 in.	3
38	Actuator Wiring Assembly, Electric	1
41	Gear Case Shaft	1
47	Thrust Washer, 1/2 x 3/4 in.	4
48	Needle Bearing, 1/2 x 3/4 in.	2
64	Repair Kit, O-ring/Gasket (Consists of 9, 10, 59, 72 and 73)	0
70	Actuator Subassembly	1
71	Hex Head Screw, 1/4-20 x 5/8 in.	4
72	Switch Cover Gasket	1
73	Actuator Housing Gasket	1

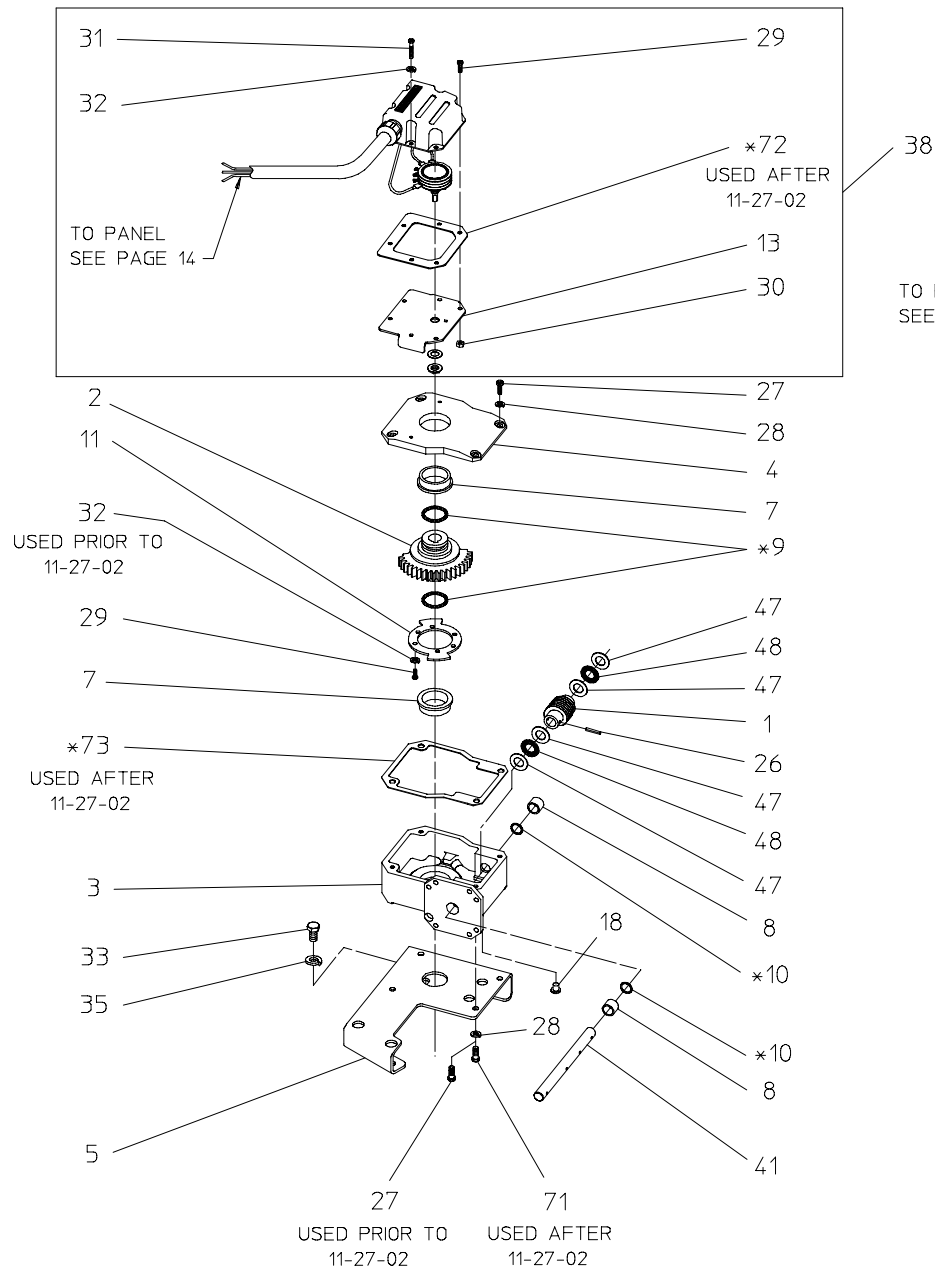

ACTUATOR SUBASSEMBLY REF 70

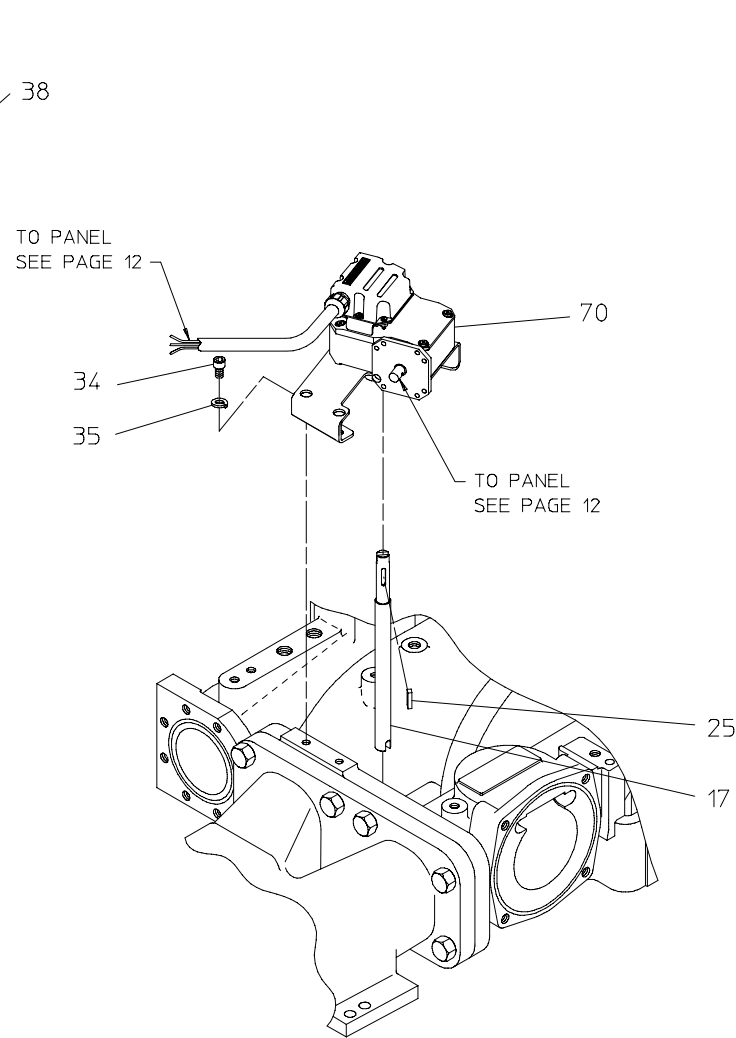

**MANUAL ACTUATOR, TOP MOUNTED**



## Manual Actuator, Bottom Mounted

REF. NO.	DESCRIPTION	QTY
1	Worm Gear	1
2	Sector Gear	1
3	Worm Gear Housing	1
4	Housing Cover	1
5	Bottom Mounting Bracket	1
7	Flanged Bearing, 1-1/4 x 1-1/2 in.	2
8	Sleeve Bearing	2
9	O-ring, 1 x 1-1/4 in.	2
10	O-ring, 1/2 x 5/8 in.	2
11	Limit Disk	1
13	Switch Mounting Bracket	1
17	Extension Shaft, Bottom	1
18	Rubber Plug	2
24	Adapter Nut, 3/4 in.	1
25	Key, 3/16 x 3/4 in.	1
26	Spirol Pin, 1/8 x 3/4 in.	2

REF. NO.	DESCRIPTION	QTY
27	Socket Head Screw, 1/4-20 x 5/8 in.	8
28	Lock Washer, 1/4 in.	8
29	Socket Head Screw, 8-32 x 1/2 in.	8
30	Nylok Nut, 8-32	4
31	Socket Head Screw, 8-32 x 7/8 in.	2
32	Lock Washer, #8	6
38	Actuator Wiring Assembly, Manual	1
39	Hex Socket Head Screw, 5/16-18 x 9/16 in.	3
40	Lock Washer, 5/16 in.	3
41	Gear Case Shaft	1
47	Thrust Washer, 1/2 x 3/4 in.	4
48	Needle Bearing, 1/2 x 3/4 in.	2
64	Repair Kit, O-ring/Gasket (Consists of 9, 10, 59, 72 and 73)	0
70	Actuator Subassembly	1
71	Hex Head Screw, 1/4-20 x 5/8 in.	4
72	Switch Cover Gasket	1
73	Actuator Housing Gasket	1

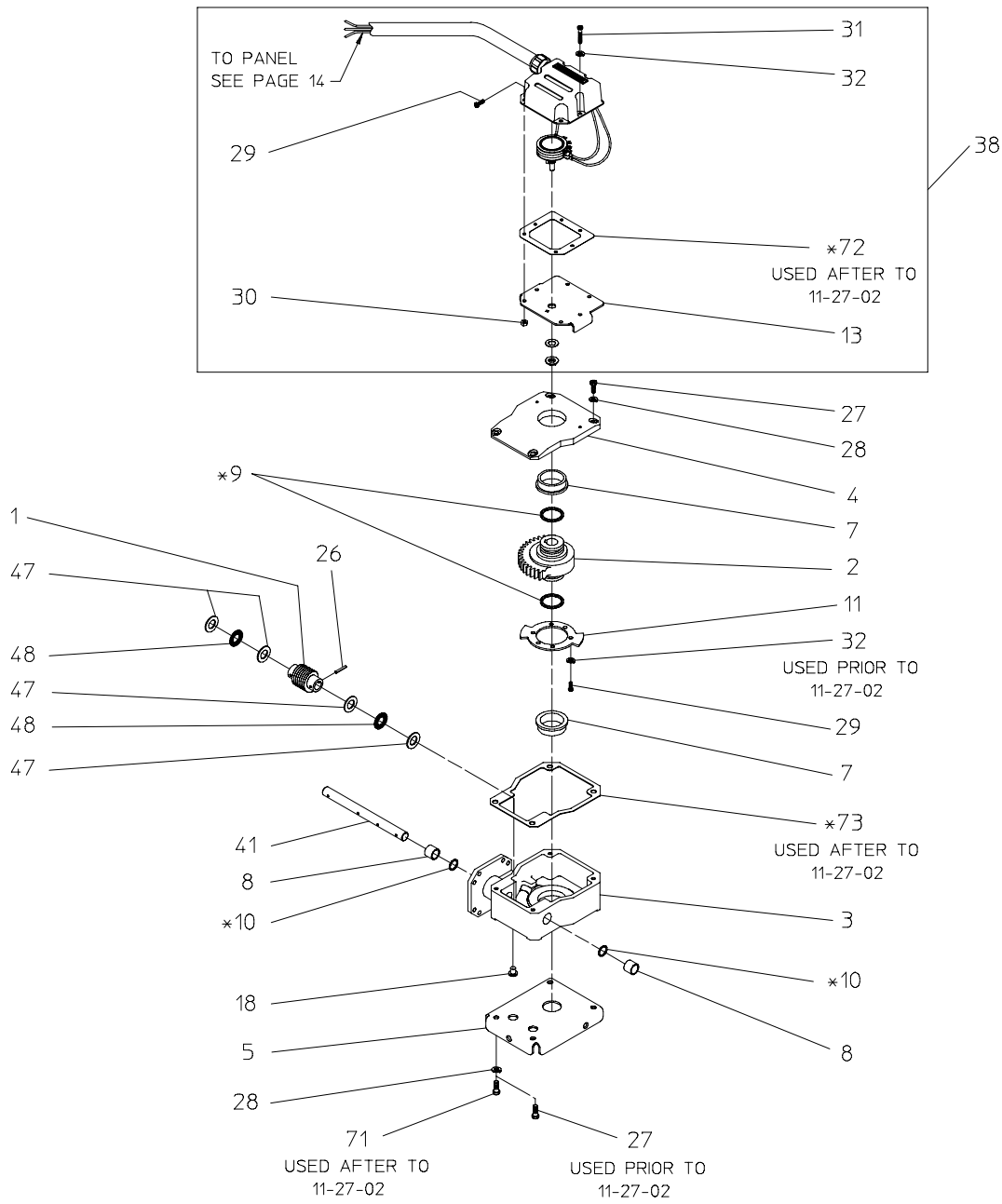

ACTUATOR SUBASSEMBLY REF 70

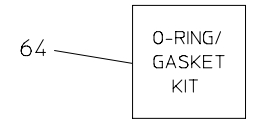

\* PART OF O-RING/GASKET  
REPAIR KIT 64

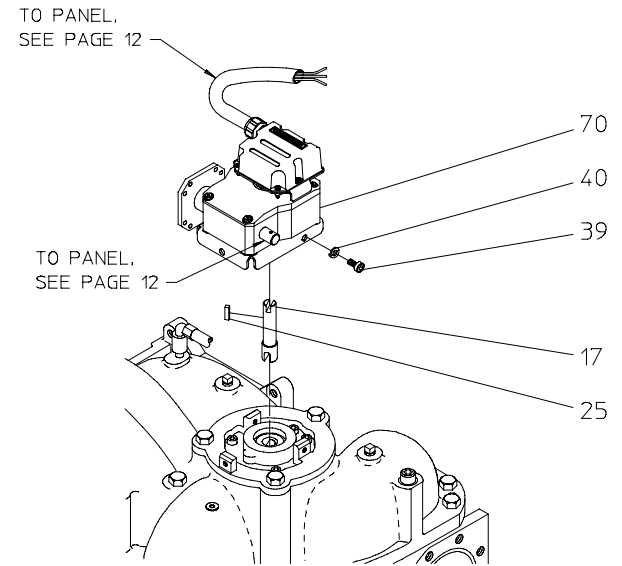

NOTE: PUMP AND ACTUATOR  
SHOWN UPSIDE DOWN FOR CLARITY

**MANUAL ACTUATOR, BOTTOM MOUNTED**

## Optional Manual Override for Electric Actuators

REF. NO.	DESCRIPTION	QTY
26	Spirol Pin, 1/8 x 3/4 in.	4
42	U-Joint	2
44	Thrust Bearing, 1/2 in.	1
45	Remote Body	1
50	Connecting Rod	1
52	Round Head Screw, 1/4-20 x 1 in.	3

REF. NO.	DESCRIPTION	QTY
53	Hex Nut, 1/4-20	3
54	Lock Washer, 1/4 in.	3
56	Remote Override Shaft	1
57	Crank Handle	1
58	Manual Override Panel Plate	1

NOTE: OVERRIDE MAY BE  
CONNECTED TO THIS  
SIDE OF ACTUATOR.

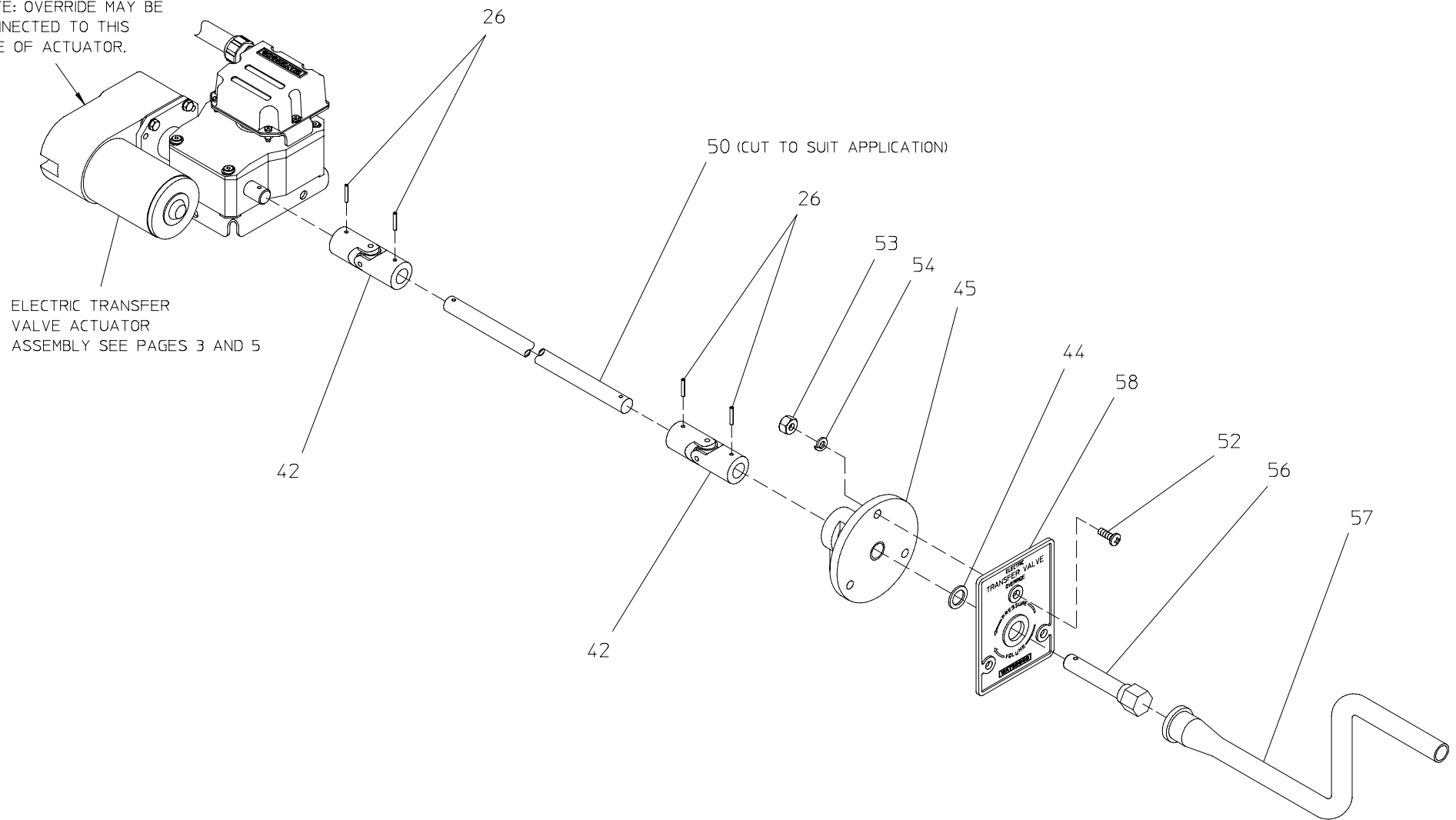

ELECTRIC TRANSFER  
VALVE ACTUATOR  
ASSEMBLY SEE PAGES 3 AND 5

50 (CUT TO SUIT APPLICATION)

**OPTIONAL MANUAL OVERRIDE FOR ELECTRIC ACTUATORS**

NOTE: PARTS SHIPPED LOOSE BY WATEROUS

SPL82395  
WATEROUS COMPANY  
SOUTH ST. PAUL, MN 55075  
REV: 01/22/08 PAGE 10 OF 14

## Manual Actuator Panel Connection and Wiring

REF. NO.	DESCRIPTION	QTY
20	Panel Light (LED), Yellow (Pressure)	1
21	Panel Light (LED), Green (Volume)	1
26	Spirol Pin, 1/8 x 3/4 in.	4
37	Panel Wiring Assembly (Manual)	1
42	U-Joint	2
43	Remote Shaft	1
44	Thrust Bearing, 1/2 in.	1

REF. NO.	DESCRIPTION	QTY
45	Remote Body	1
46	Handle	1
50	Connecting Rod	1
51	Spirol Pin, 3/16 x 1-1/4 in.	1
52	Round Head Screw, 1/4-20 x 1 in.	3
53	Hex Nut, 1/4-20	3
54	Lock Washer, 1/4 in.	3

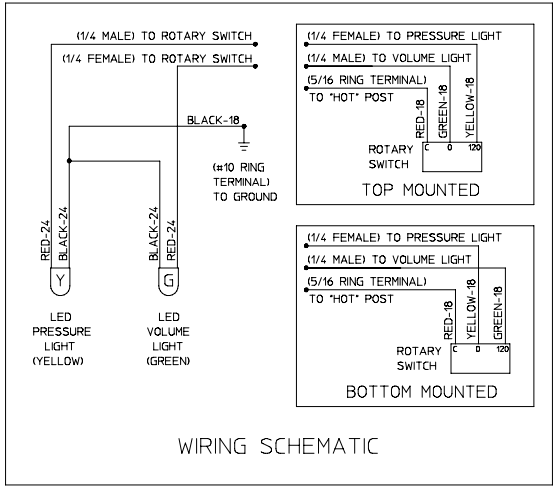
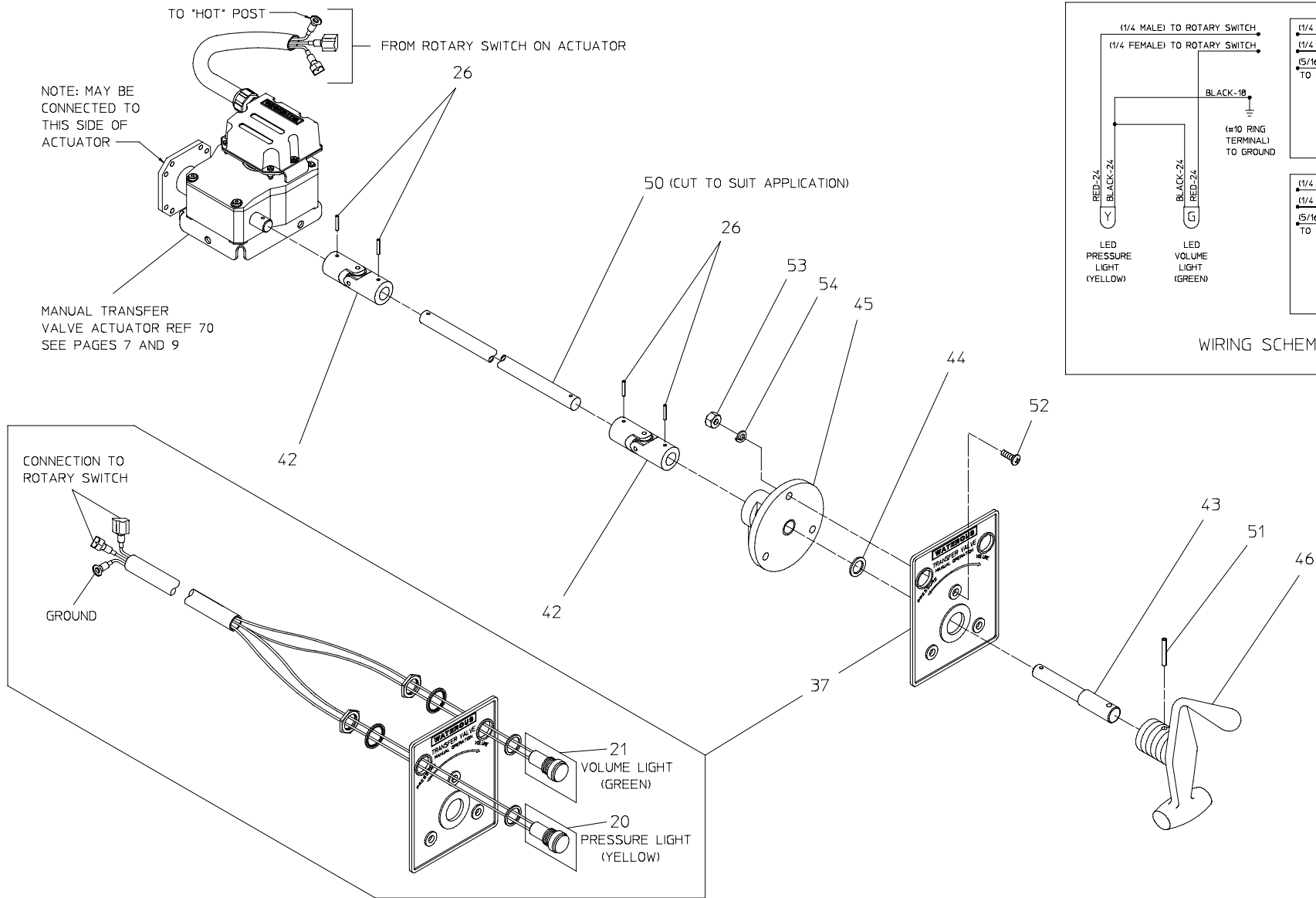

**MANUAL ACTUATOR PANEL CONNECTION AND WIRING**

## Electric Actuator Panel Connection and Wiring

REF. NO.	DESCRIPTION	QTY
20	Panel Light (LED), Yellow (Pressure)	1
21	Panel Light (LED), Green (Volume)	1
22	Switch	1

REF. NO.	DESCRIPTION	QTY
23	Circuit Breaker	1
37	Panel Wiring Assembly (Electric)	1

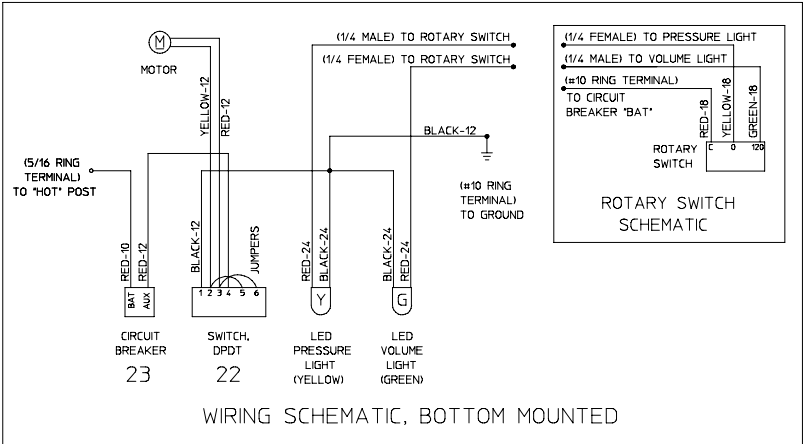
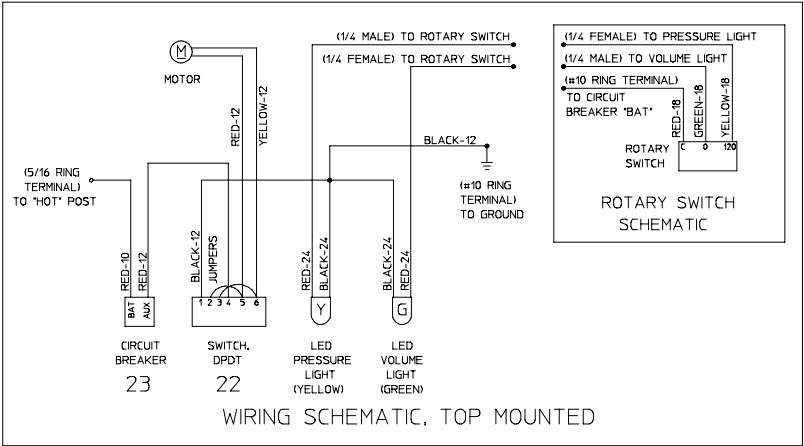
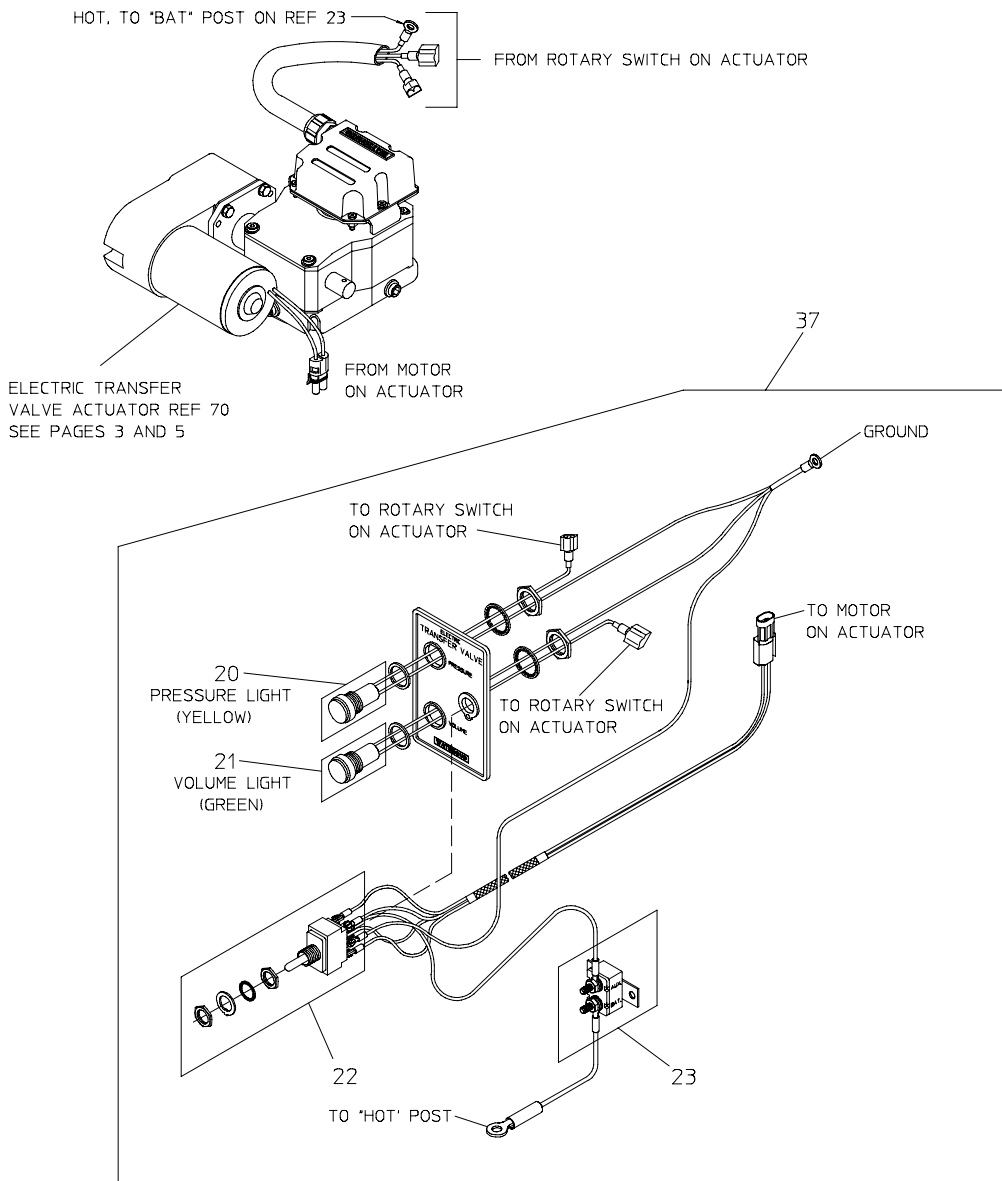

**ELECTRIC ACTUATOR PANEL CONNECTION & WIRING**