

### PB18G-2015B & PB18G-2015F Portable Pump Service Parts List

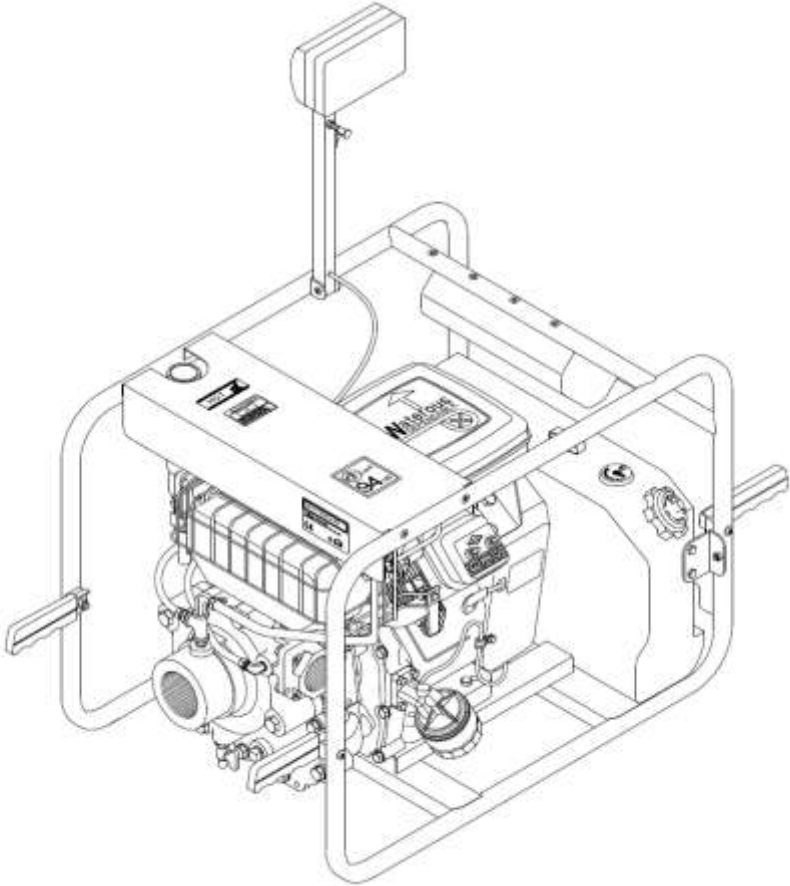

## Pump Assembly – Models PB18G-2015B & PB18G-2015F

REF NO.	DESCRIPTION
1	Drain Cock
18	Male Connector, 90°, 3/8 Tube
20	Poly Tubing, 3/8 O.D.
26	Headless Pipe Plug, 1/4 in.
28	Serial Plate
29	Pipe Nipple, 1/4 x 7/8 in.
32	Nylon Tubing, 1/4 O.D., 32 in.
33	Nylon Tubing, 1/4 O.D., 34 in.
35	Male Elbow, 1/4 NPT x 1/4 O.D.
36	Male Connector, 1/4 NPT x 1/4 O.D.
97	Pipe Tee, 1/4 in.
99	Volute Body Subassembly
101	Wear Ring
102	Hex Hd Screw, 3/8-24 x 1-1/8 in.
103	Impeller Washer
104	Impeller
105	Mechanical Seal
106	O-ring, 5-3/4 x 6 in.
107	Square Key, 3/16 x 1 in.
108	Socket Hd Screw, 3/8-16 x 1-1/2 in.
109	Copper Washer, 3/8 in.
110	Lock Washer, 7/16 in.
111	Hex Hd Screw, 7/16-20 x 3 in.
113	Shaft Sleeve
114	Gear Case Cover Subassembly
115	O-ring, 1 x 1-1/8 in.
116	Lock Washer, 3/8 in.

REF NO.	DESCRIPTION
117	Hex Hd Screw, 7/16-20 x 2-3/4 in.
118	Hex Nut, 7/16-20
119	Impeller Nut
120	Plain Washer, 1/2 in. or Nord-Lock Washer, 1/2 in.
121	Oi Seal
122	Ball Bearing
123	Driven Gear Shaft, 17T
124	Thrust Needle Bearing
125	Square Key, 1/4 x 1-1/8 in.
127	Gear Case Subassembly
128	Oil Seal
129	Gear Case Gasket
130	Drive Gear, 48T
131	Magnetic Plug, 3/8 in.
132	Hex Hd Screw, 3/8-16 x 1 in.
133	Discharge Adapter, 1-1/2 NPT (F)
134	Pipe Plug, 3/8 NPT
135	Pipe Nipple, 3/8 x 3 in.
136	Breather
137	Standard Elbow, 90°, 3/8 in.
138	Dowel Pin, 5/16 x 3/4 in.
139	O-ring, 1-15/16 x 2-1/8 in.
142	Socket Hd Screw, 1/4-20 x 1 in.
143	Hex Hd Screw, 1/4-20 x 3/4 in.
144	Ball Valve
147	Drive Screw, #6 x 1/4 in.
238	Impeller Gasket

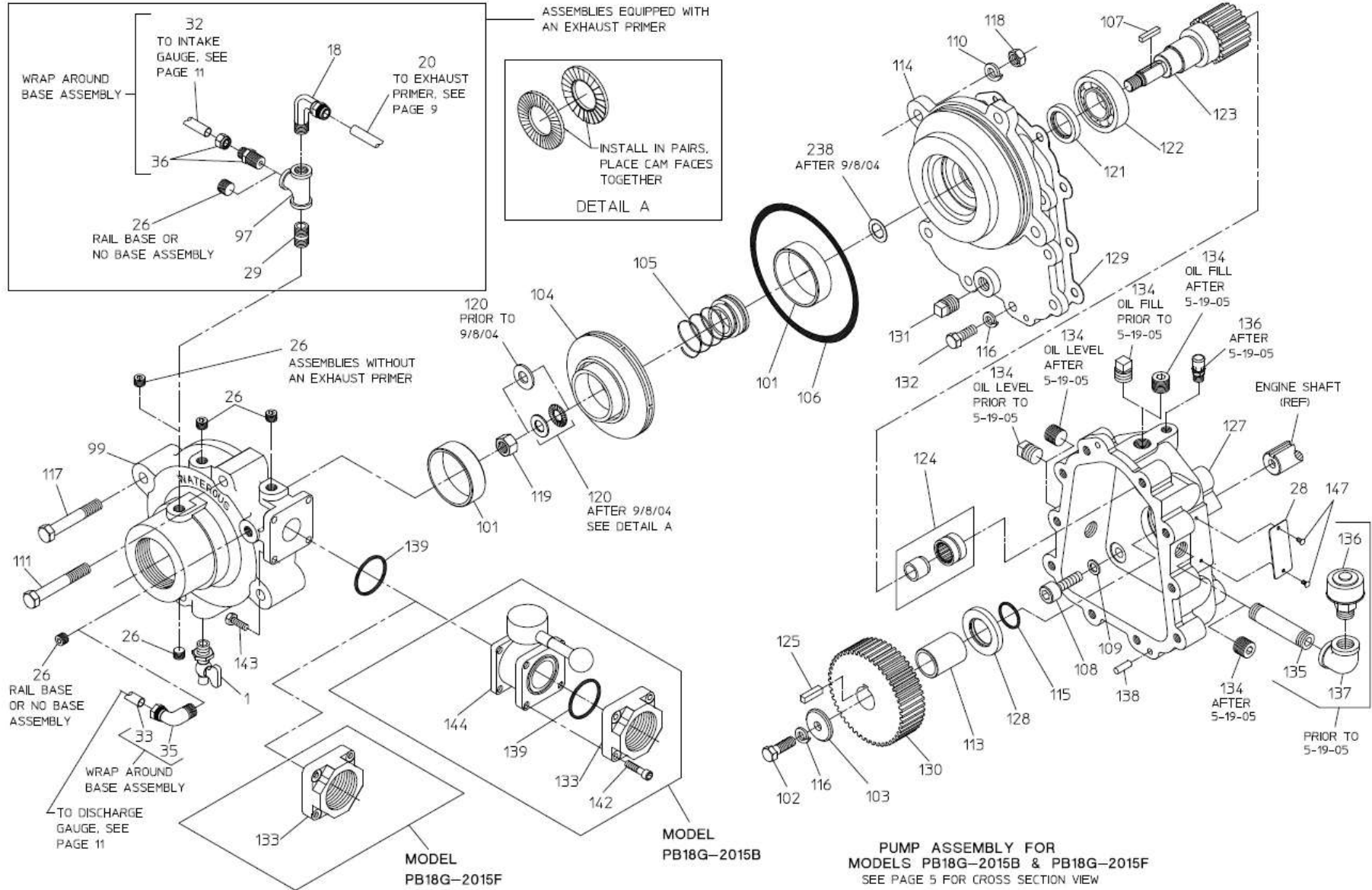

## Pump Assembly – Models PB18G-2015B & PB18G-2015F

REF NO.	DESCRIPTION
101	Wear Ring
102	Hex Hd Screw, 3/8-24 x 1-1/8 in.
103	Impeller Washer
104	Impeller
105	Mechanical Seal
106	O-ring, 5-3/4 x 6 in.
107	Square Key, 3/16 x 1 in.
108	Socket Hd Screw, 3/8-16 x 1-1/2 in.
109	Copper Washer, 7/16 in.
110	Lock Washer, 7/16 in.
111	Hex Hd Screw, 7/16-20 x 3 in.
113	Shaft Sleeve
115	O-ring, 1 x 1-1/8 in.
116	Lock Washer, 3/8 in.
117	Hex Hd Screw, 7/16-20 x 2-3/4 in.
118	Hex Nut, 7/16-20
119	Impeller Nut

REF NO.	DESCRIPTION
120	Plain Washer, 1/2 in. or Nord-Lock Washer, 1/2 in.
121	Oil Seal
122	Ball Bearing
123	Driven Gear Shaft, 17T
124	Thrust Needle Bearing
125	Square Key, 1/4 x 1-1/8 in.
128	Oil Seal
129	Gear Case Gasket
130	Drive Gear, 48T
131	Magnetic Plug, 3/8 in.
132	Hex Hd Screw, 3/8-16 x 1 in.
134	Pipe Plug, 3/8 NPT
135	Pipe Nipple, 3/8 x 3 in.
136	Breather
137	Standard Elbow, 90°, 3/8 in.
138	Dowel Pin, 5/16 x 3/4 in.
238	Impeller Gasket

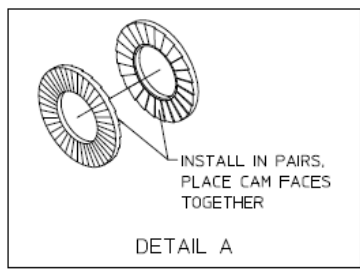
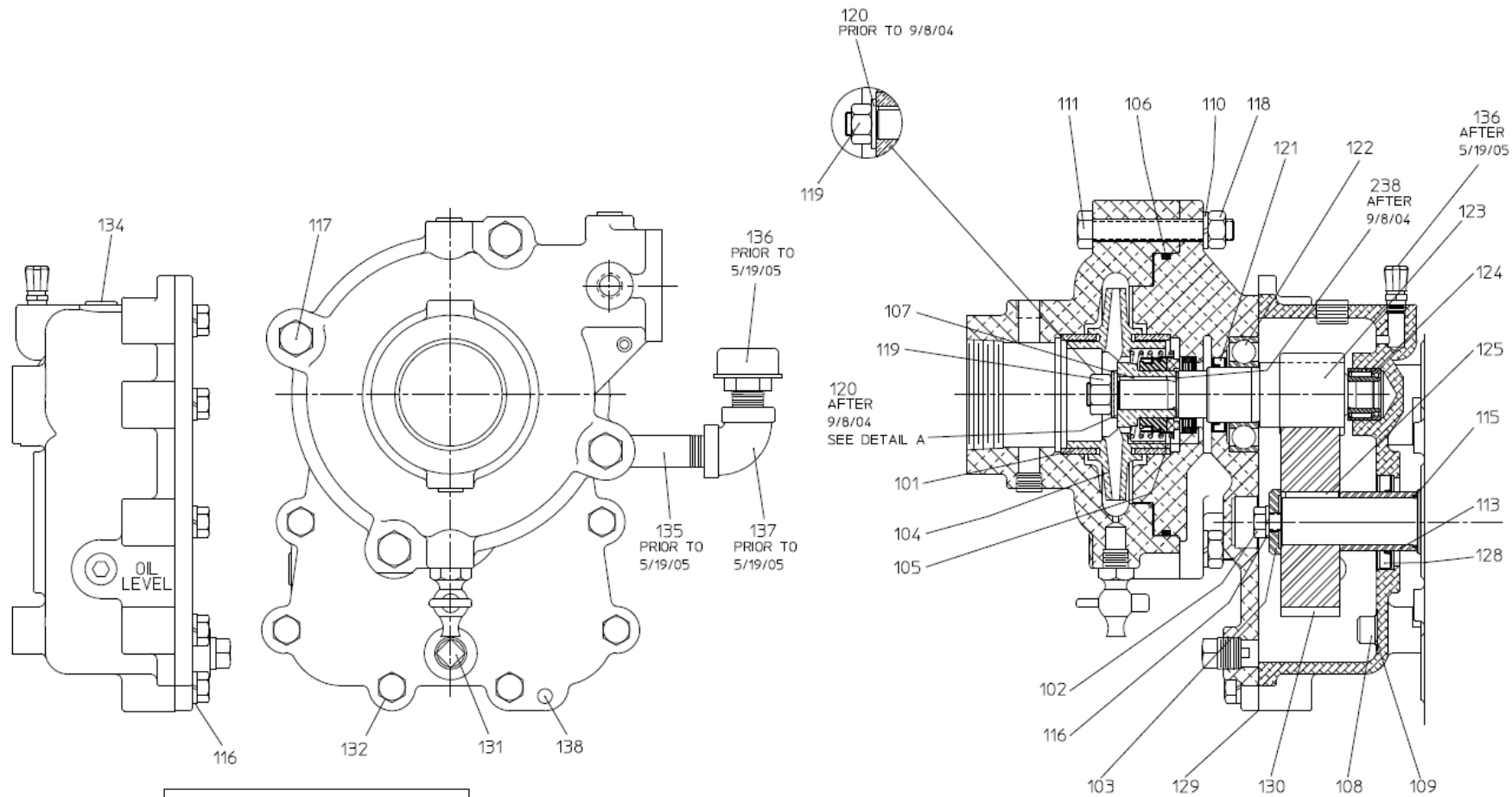

MODELS PB18G-2015B & PB18G-2015F PUMP ASSEMBLY

## Engine and Muffler

REF NO.	DESCRIPTION
34	Engine, 18HP
84	Vanguard Decal
89	Primer Base
94	Muffler
141	Self-Locking Screw
150	Oil Pressure Switch Wire Assembly

REF NO.	DESCRIPTION
155	Wire Clamp
204	Oil Pressure Switch
225	Muffler Guard
234	Muffler Screw
235	Muffler Gasket
236	Muffler Guard Screw

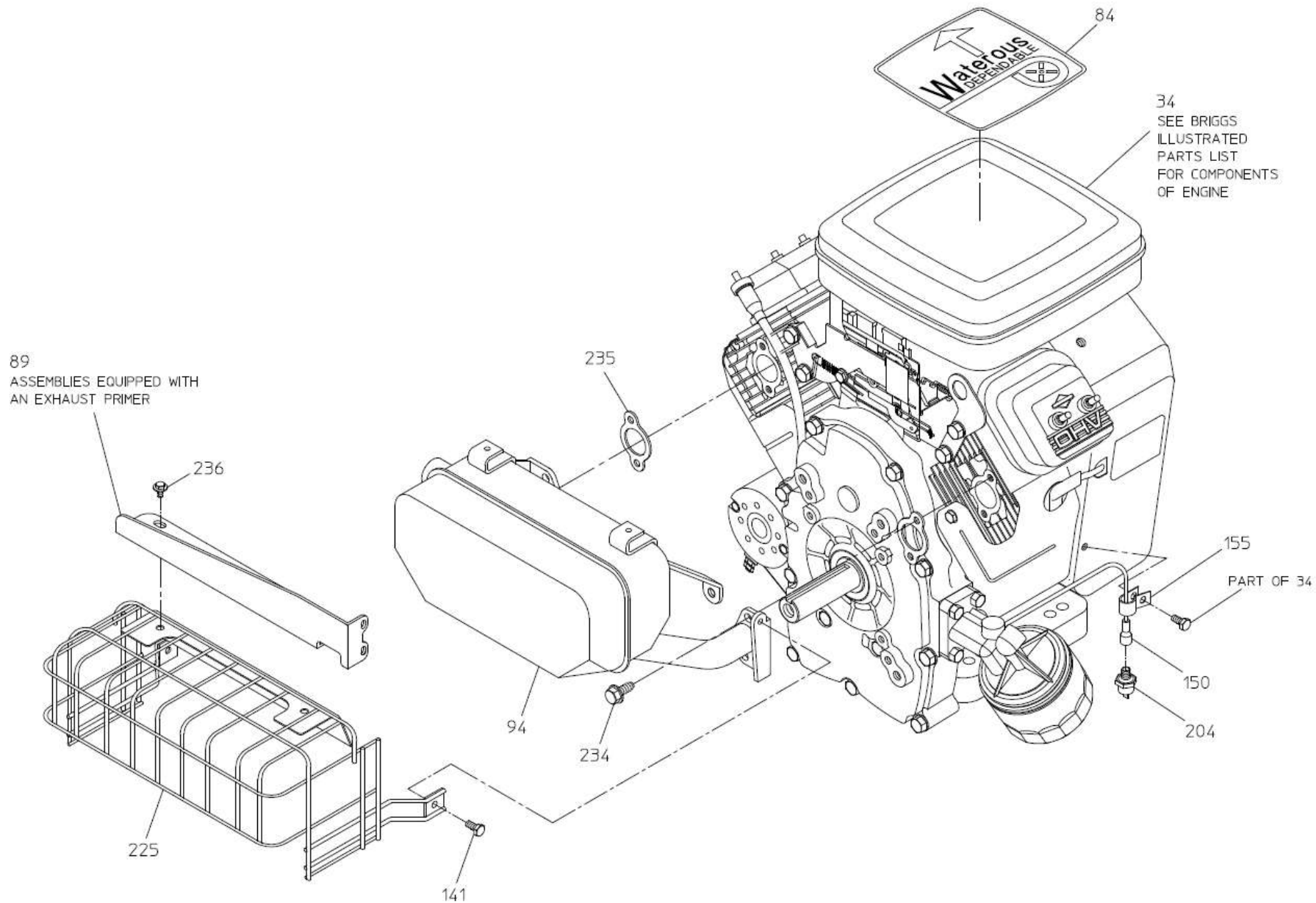

ENGINE AND MUFFLER

## Engine and Exhaust Primer

REF NO.	DESCRIPTION
12	Pan Hd Screw, #10-24 x 1/2 in.
18	Male Connector, 90°, 3/8 Tube
20	Poly Tubing, 3/8 O.D.
27	Compression Elbow, 1/4 NPT x 3/8 Tube
34	Engine, 18 HP
40	Hex Nut, 5/16-18
41	Primer Lever
43	Hex Nut, 1/4-28
44	Socket Hd Screw, #10-24 x 5/8 in.
51	Rod End
59	Plain Washer, 1/4 in.
62	Lock Washer, #10
64	Ball Valve, 1/4 NPT
65	Socket Hd Screw, #10-24 x 3/8 in.
66	Ductile Iron Primer
75	Linkage Rod
77	Spark Arrestor

REF NO.	DESCRIPTION
81	Primer Gasket
86	Copper Primer Tube, 3/8 O.D.
87	Exhaust Primer Subassembly
88	Butterfly Valve
90	Pan Hd Screw, #8-32 x 3/8 in.
91	Lock Washer, #8
92	Set Screw, 1/4-20 x 1/2 in.
93	Primer Rod
95	Primer Adapter
96	Priming Rod Bracket
98	Nylon Split Bushing
100	Bar Knob
151	Compression Spring
152	Hex Hd Screw, 1/4-20 x 1 in.
153	Hex Nut, 1/4-20
154	Hex Hd Screw, 8 mm x 20 mm



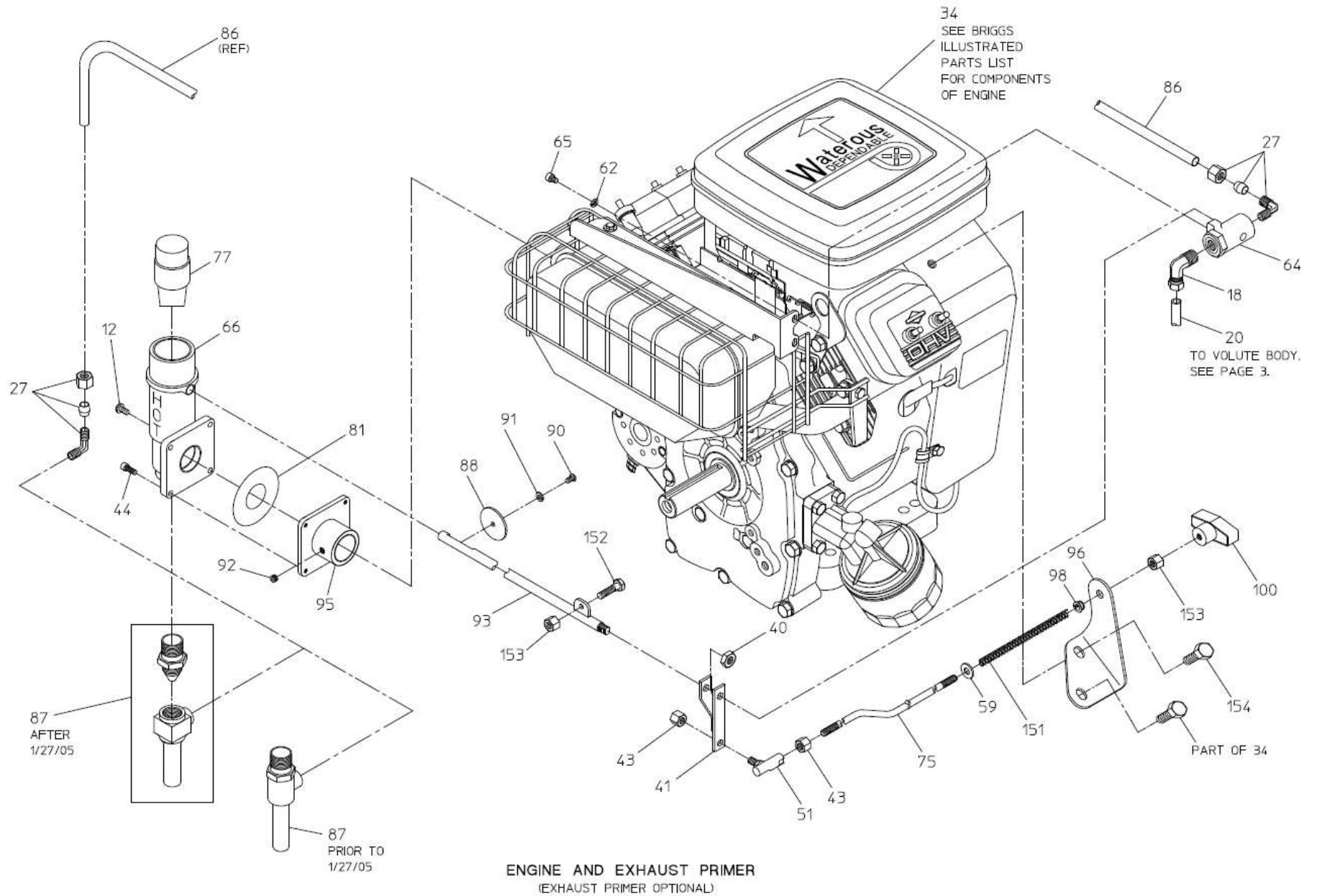

## Instrument Panel

REF NO.	DESCRIPTION
2	Panel Light
3	Nylok Nut, #10-24
4	Throttle Control
6	Panel Plate
7	Intake Gauge
8	Connector Cap
9	Discharge Gauge
10	Ignition Switch
11	Switch Knob
12	Pan Hd Screw, #10-24 x 1/2 in.
13	Panel Light Switch
14	Switch Seal

REF NO.	DESCRIPTION
15	Panel Fuse Holder
16	5 Amp Fuse
17	Oil Light
32	Nylon Tubing, 1/4 O.D., 32 in.
33	Nylon Tubing, 1/4 O.D., 34 in.
56	Harness Extension
73	Panel Insert
74	Instrument Panel Subassembly
112	Gauge Adapter Ring
126	Female Elbow, 90°, 1/4 NPT x 1/4 O.D.
140	12 Volt Lamp, 5 Watt

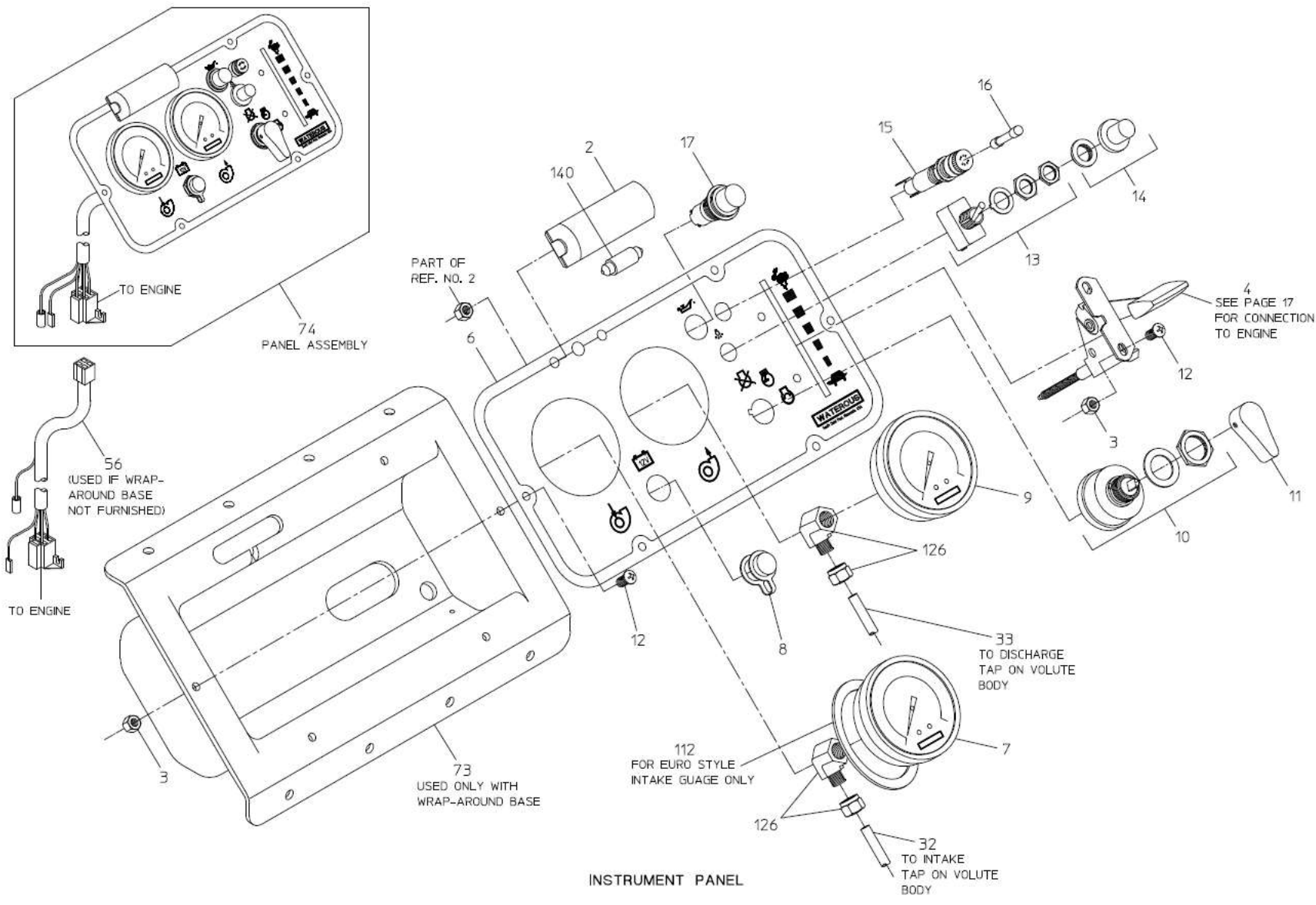

## Wrap-Around Base

REF NO.	DESCRIPTION
19	Battery Tray
21	Carry Handle
22	Grip Handle
23	Button Hd Screw, 5/16-18 x 2 in.
24	Plain Washer, 5/16 in.
25	Tank Bracket
30	Heat Shield
31	Mast Light Bulb, 12V
37	Hex Hd Screw, 5/16-18 x 1-3/4 in.
39	Nylok Nut, 5/16-18
42	Pan Hd Screw, 1/4-20 x 3/4 in.
45	Wrap-Around Frame
46	Fuel Tank (Includes 76 & 78)
47	Hex Hd Screw, 1/4-20 x 1/4 in.
48	Shoulder Socket Screw, 1/4-20 x 1/4 in.
49	Fuel Gauge
50	Rubber Grommet
52	Fuel Tank Cap
53	Battery Strap
55	Fuel Line
57	Self Tap Screw, #8-18 x 1/2 in.
58	Pan Hd Screw, 1/4-20 x 1 in.
59	Plain Washer, 1/4 in.

REF NO.	DESCRIPTION
60	Acorn Nut, 1/4-20
61	Mast Light Assembly
63	Pan Hd Screw, 1/4-20 x 1-1/2 in.
67	Strap Clip
68	Nylok Nut, 1/4-20
69	Nylon Washer, 5/16 in.
70	Mast Light
71	Snap-In Slide Switch
72	Oval Hd Screw, 1/4-20 x 1-1/2 in.
76	Fuel Tank Hose Barb
78	Fuel Tank Grommet
79	Flat Hd Screw, 1/4-20 x 1 in.
80	Hot Decal
83	Spring Hose Clamp, 17/32 in.
85	Warning Label
145	CE Marking Decal
146	94 Decibel Decal
148	Negative Wire Assembly
149	Positive Wire Assembly
156	Fuel Valve
158	Pan Hd Screw, 1/4-20 x 2-1/2 in.
159	Thread Cap
237	Thin Style Nylok Nut, 5/16-18

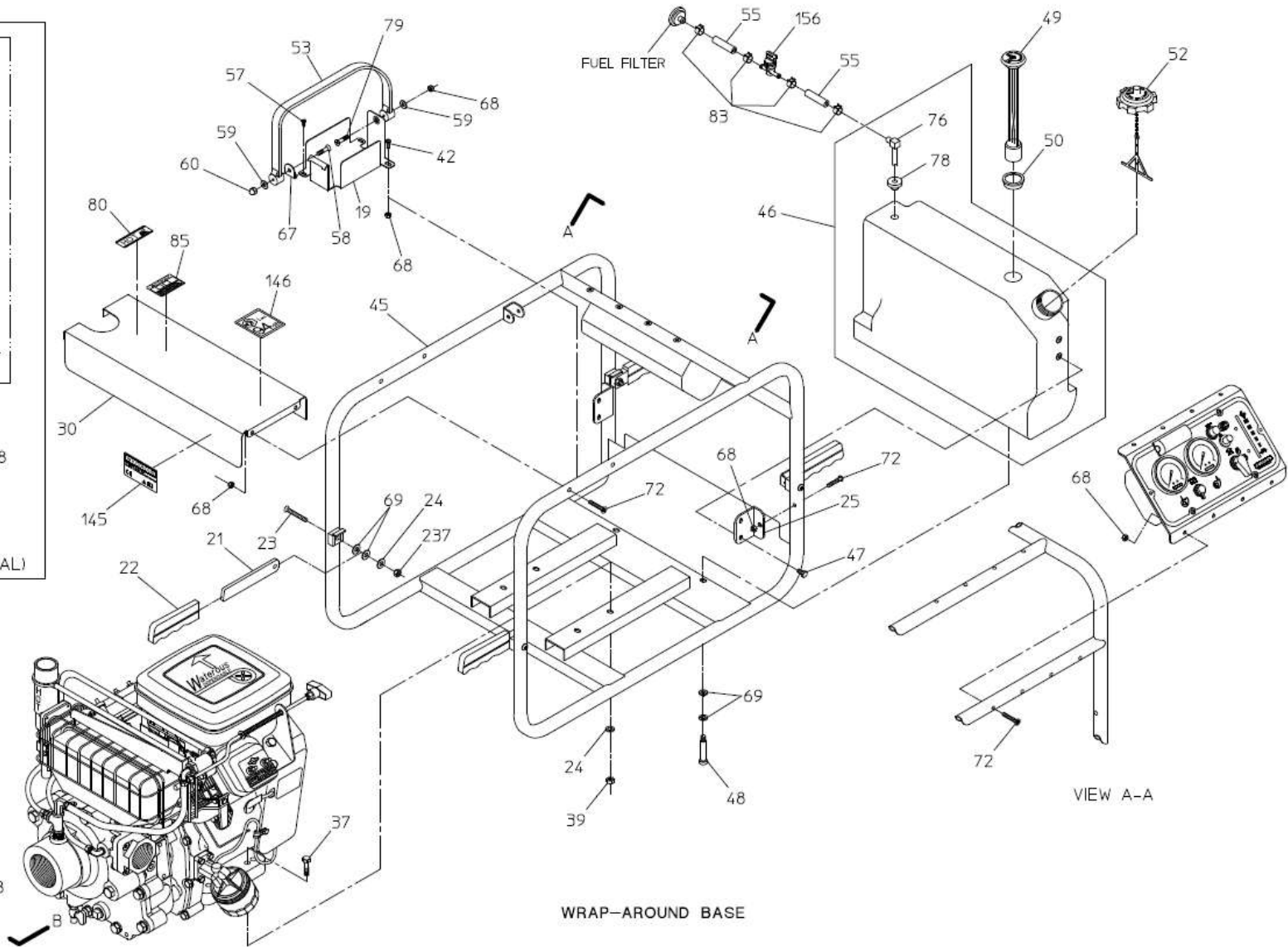
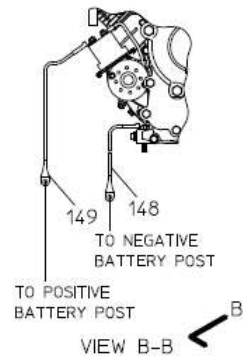
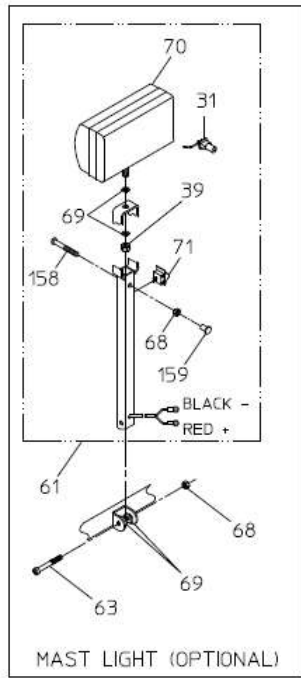

## Rail Base

REF NO.	DESCRIPTION
24	Plain Washer, 5/16 in.
37	Hex Hd Screw, 5/16-18 x 1-3/4 in.
38	Rail Base
39	Nylok Nut, 5/16-18
46	Fuel Tank (Includes 76 & 78)
49	Fuel Gauge
50	Rubber Grommet
52	Fuel Tank Cap
54	Fuel Line

REF NO.	DESCRIPTION
55	Fuel Line
76	Fuel Tank Hose Barb
78	Fuel Tank Grommet
83	Spring Hose Clamp, 17/32 in.
85	Warning Label
148	Negative Wire Assembly
149	Positive Wire Assembly
156	Fuel Valve

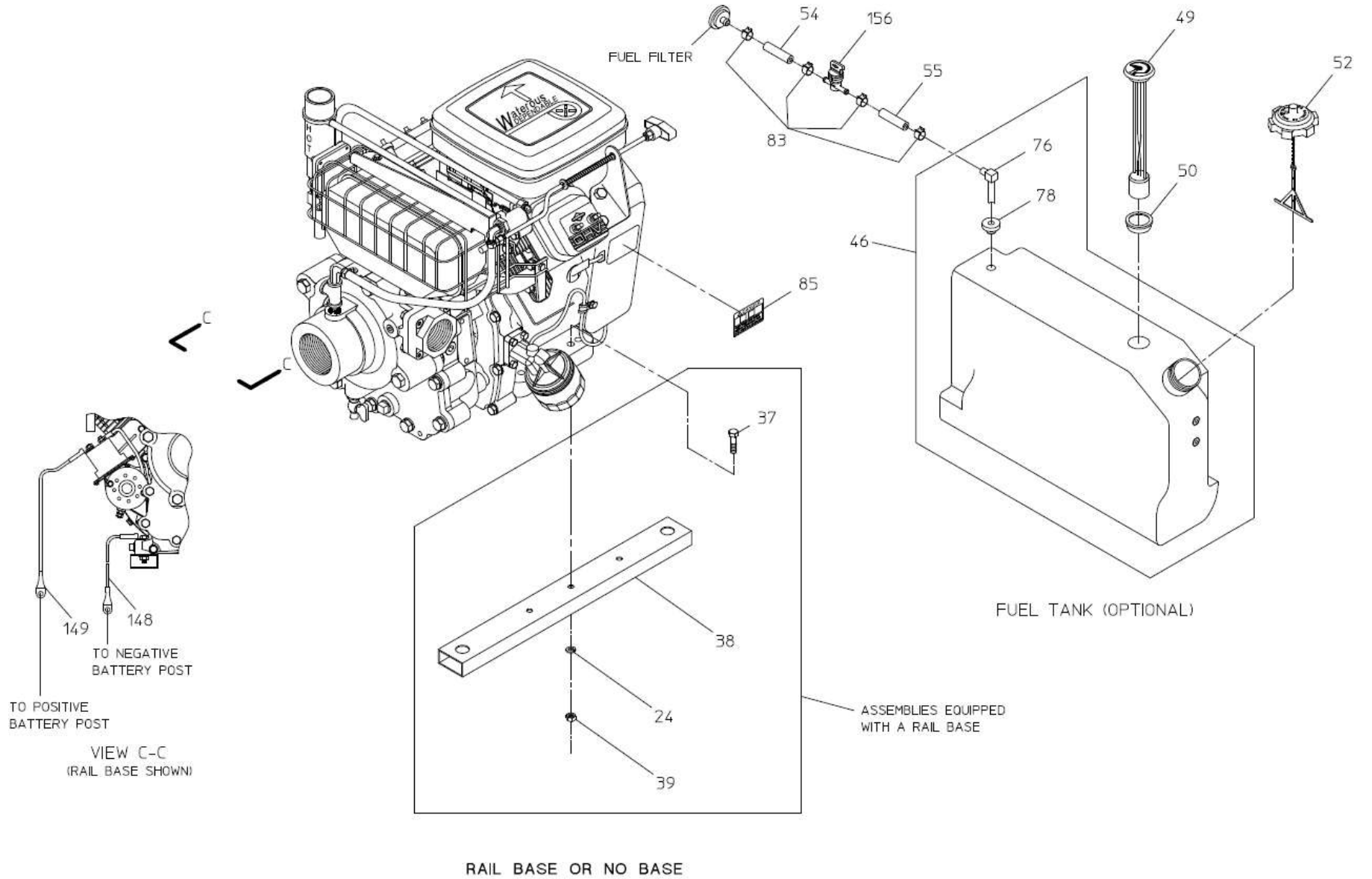

## Wiring Schematic

REF NO.	DESCRIPTION
2	Panel Light
4	Throttle Control
10	Ignition Switch

REF NO.	DESCRIPTION
13	Panel Light Switch
15	Panel Fuse Holder
17	Oil Light



