

C20 Series Transmission Service Parts List

As used with CM, CS, CG, CX, CMH and CSH Pump Models

Index:

Components				See Page	
Type	Pump Model	Rear Output Configuration (Output Shaft Side)			
Driven Shaft	Separable Impeller Shaft	CM, CMU CS, CSU	None (Blank)	2, 3	
			Eclipse™, 150-D, 150-OS CAFS	4, 5	
			1-3/8 in. Keyed Shaft		
				Hydraulic Pump (SAE Class B 2-Bolt Hydraulic Flange)	6, 7
				Combination Pump	8, 9
				Oil Cooler	10, 11
Driven Shaft	Non-Separable Impeller Shaft	CGV, CGVG, CGVN, CGVR, CXN, CXR, CXS, CXV	None (Blank)	12, 13	
			Eclipse™ ES, 150-ESD, 150-ESOS CAFS	14, 15	
				Hydraulic Pump (SAE Class B 2-Bolt Hydraulic Flange)	16, 17
		CMH, CMUH, CSH, CSUH	None (Blank)	18, 19	
Driveline	Input and Output Shaft (Standard Driveline)		Exploded View	20, 21	
			Cross-Section View	22, 23	
	Input Shaft Only (Standard Driveline)		Exploded View	24, 25	
			Cross-Section View	26, 27	
Input and Output Shaft (High Speed Driveline)		Exploded View	28, 29		
		Cross-Section View	30, 31		
Shift Unit	See Pneumatic Shift Service Parts List			-	
Case	Viewed from Input Shaft Side		Pumps Built After January 1, 2011	32, 33	
			Pumps Built Prior to January 1, 2011	34, 35	
	Viewed from Output Shaft Side		Pumps Built After January 1, 2011	36, 37	
			Pumps Built Prior to January 1, 2011	38, 39	
			Spacers, Shims and Sealant Application	Models C20B, C20C, C20D, C20E, C20F	40, 41
	Cap Variations	Hardware		Models C20B	42, 43
				Models C20C, C20D	44, 45
Models C20E, C20F				46, 47	
	Oil Cooler Option			48-55	
Optional Accessories	Transmission Mounted Drain Valve		See Drain Valve Service List		
	Model VPO Priming Pump		See Priming Pump Service Parts List		

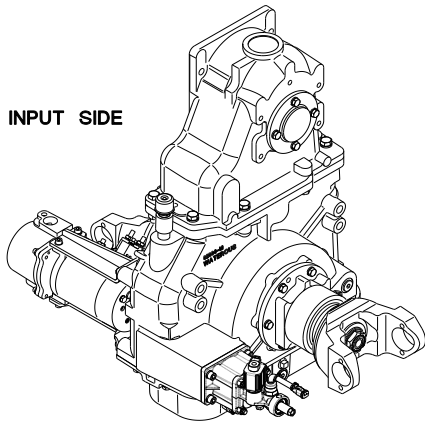

INPUT SIDE

OUTPUT SIDE

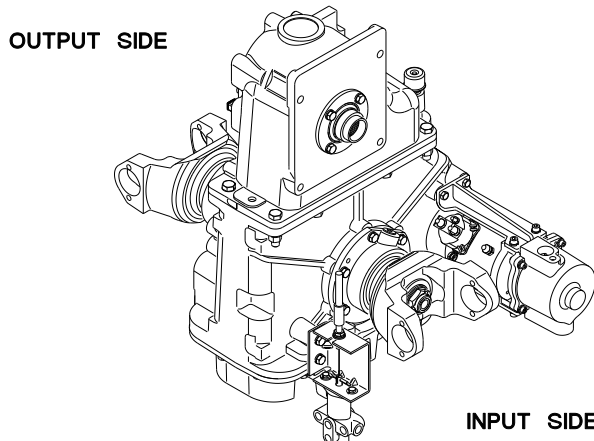

OUTPUT SIDE

INPUT SIDE

Driven Shaft - Separable Impeller Shaft

Rear Output Configuration: None

REF. NO.	DESCRIPTION
T8	Hex Hd Screw, 3/8-16 x 1 in.
T9	Lock Washer, 3/8 in.
T18	Chain
T19	Oil Seal, 1-7/8 x 2-3/4 x 5/16 in.
T23	Oil Seal Housing
T24	Oil Seal Housing Gasket
T25	Single Row Ball Bearing
T26	Driven Sprocket
T29	Bearing Spacer, .380 in. Wide
T31	Bearing Cover
T32	Bearing Lock Nut Washer (W07)
T33	Bearing Lock Nut (N07)

REF. NO.	DESCRIPTION
T40	Wave Spring, 80 mm
T65	Case Cap
T95	Bearing Spacer, 1.215 Wide
T120	Driven Shaft
T121	Driven Shaft Boot
T130	Square Key, 5/16 x 2-5/16 in.
T133	O-ring, 3-1/4 x 3-7/16 in.
T141	Gasket and O-ring Repair Kit

Hardware Torque Specifications

Screw Size	Torque Specification
5/16-18 UNC	17 lb-ft
3/8-16 UNC	31 lb-ft
1/2-13 UNC	75 lb-ft
1/2-20 UNF	85 lb-ft
5/8-11 UNC	150 lb-ft

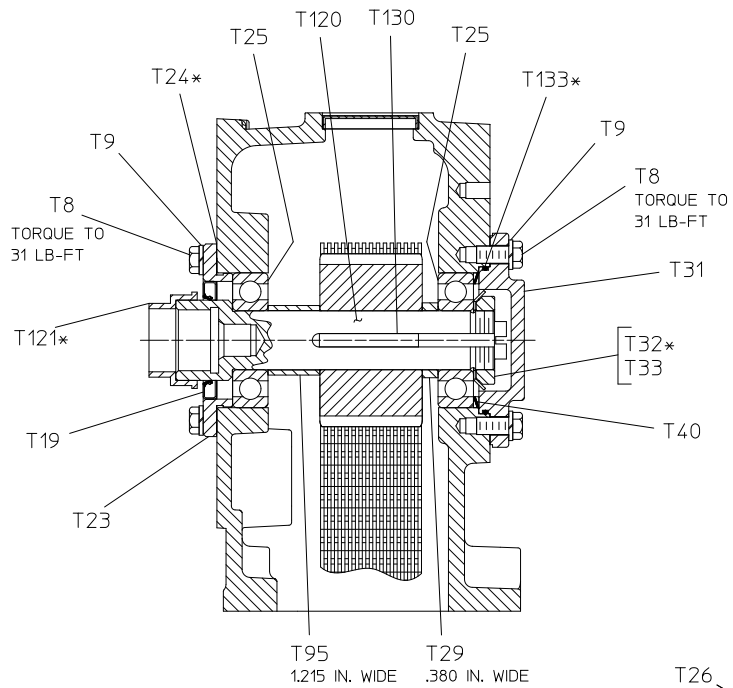

**OUTPUT SHAFT SIDE
(REAR)**

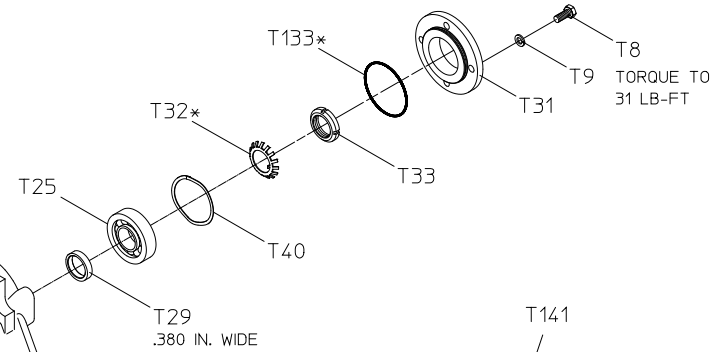

T141
 GASKET AND O-RING
 REPAIR KIT
 *PART OF T141 GASKET
 AND O-RING REPAIR KIT

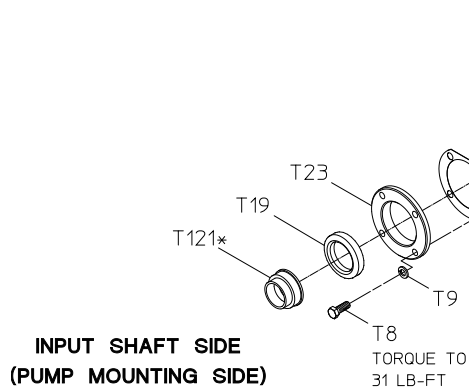

**INPUT SHAFT SIDE
(PUMP MOUNTING SIDE)**

**DRIVEN SHAFT
SEPARABLE IMPELLER SHAFT**
 PUMP MODELS: CM, CMU, CS, CSU
 REAR OUTPUT CONFIGURATION: NONE

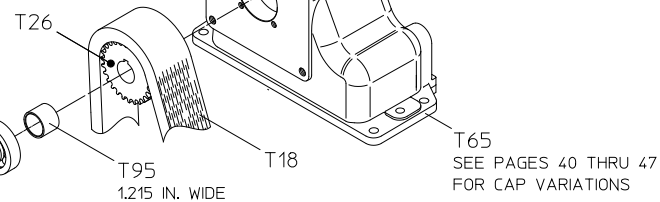

Driven Shaft - Separable Impeller Shaft

Rear Output Configuration: Eclipse™, 150-D, 150-OS CAFS or 1-3/8 in. Keyed Shaft

REF. NO.	DESCRIPTION
T8	Hex Hd Screw, 3/8-16 x 1 in.
T9	Lock Washer, 3/8 in.
T18	Chain
T19	Oil Seal, 1-7/8 x 2-3/4 x 5/16 in.
T23	Oil Seal Housing
T24	Oil Seal Housing Gasket
T25	Single Row Ball Bearing
T26	Driven Sprocket
T29	Bearing Spacer, .380 in. Wide
T31	Bearing Cover

REF. NO.	DESCRIPTION
T40	Wave Spring, 80 mm
T95	Bearing Spacer, .667 Wide
T120	Driven Shaft
T121	Driven Shaft Boot
T125	Double Row Ball Bearing
T126	Square Key, 5/16 x 1-3/4 in.
T127	Oil Seal, 1-3/8 x 2-5/8 x 5/16 in.
T129	Retaining Ring
T130	Square Key, 5/16 x 2-5/16 in.
T133	O-ring, 3-1/4 x 3-7/16 in.
T141	Gasket and O-ring Repair Kit

Hardware Torque Specifications

Screw Size	Torque Specification
5/16-18 UNC	17 lb-ft
3/8-16 UNC	31 lb-ft
1/2-13 UNC	75 lb-ft
1/2-20 UNF	85 lb-ft
5/8-11 UNC	150 lb-ft

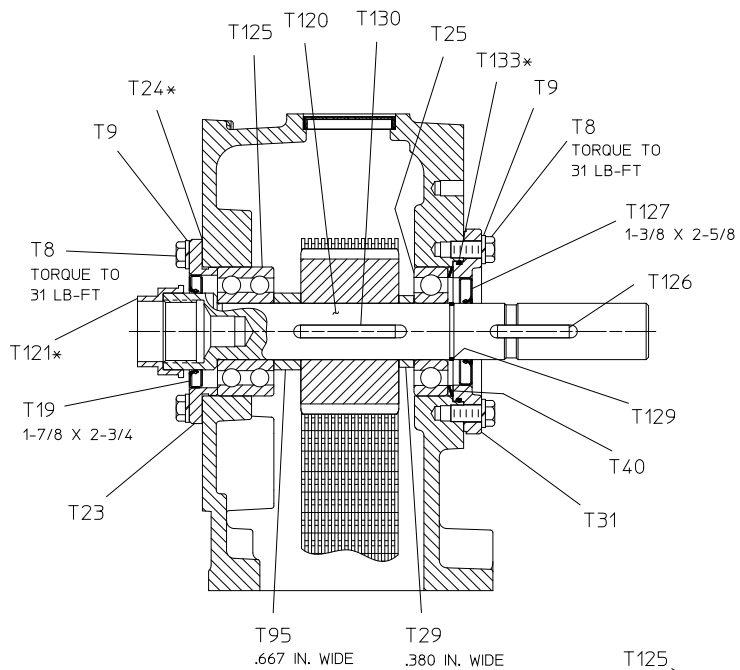

**OUTPUT SHAFT SIDE
(REAR)**

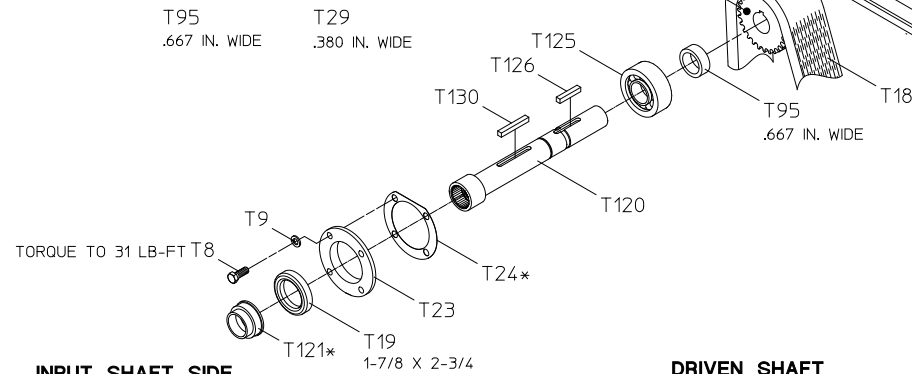
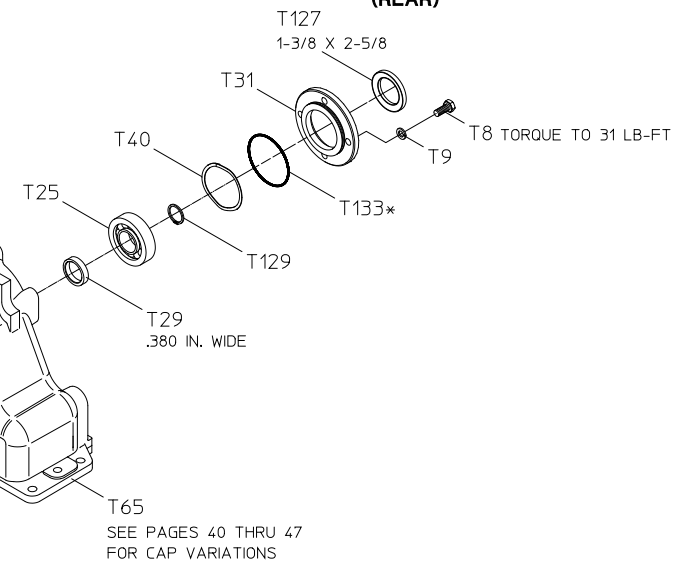

**INPUT SHAFT SIDE
(PUMP MOUNTING SIDE)**

**DRIVEN SHAFT
SEPARABLE IMPELLER SHAFT**

PUMP MODELS: CM, CMU, CS, CSU
 REAR OUTPUT CONFIGURATION:
 ECLIPSE™, 150-D, 150-OS CAFS OR 1-3/8 IN. KEYED SHAFT

T141
 GASKET AND O-RING
 REPAIR KIT
 *PART OF T141 GASKET
 AND O-RING REPAIR KIT

Driven Shaft - Separable Impeller Shaft
Rear Output Configuration: Hydraulic Pump

REF. NO.	DESCRIPTION
T8	Hex Hd Screw, 3/8-16 x 1 in.
T9	Lock Washer, 3/8 in.
T18	Chain
T19	Oil Seal, 1-7/8 x 2-3/4 x 1/4 in.
T23	Oil Seal Housing
T24	Oil Seal Housing Gasket
T25	Single Row Ball Bearing
T26	Driven Sprocket
T29	Bearing Spacer, .380 in. Wide

REF. NO.	DESCRIPTION
T40	Wave Spring, 80 mm
T65	Case Cap
T95	Bearing Spacer, 1.215 Wide
T120	Driven Shaft
T121	Driven Shaft Boot
T122	Hydraulic Adapter, SAE Class B 2-Bolt
T128	Oil Seal, 1-3/8 x 2 x 5/16 in.
T129	Retaining Ring
T130	Square Key, 5/16 x 2-5/16 in.
T133	O-ring, 3-1/4 x 3-7/16 in.
T141	Gasket and O-ring Repair Kit

Hardware Torque Specifications

Screw Size	Torque Specification
5/16-18 UNC	17 lb-ft
3/8-16 UNC	31 lb-ft
1/2-13 UNC	75 lb-ft
1/2-20 UNF	85 lb-ft
5/8-11 UNC	150 lb-ft

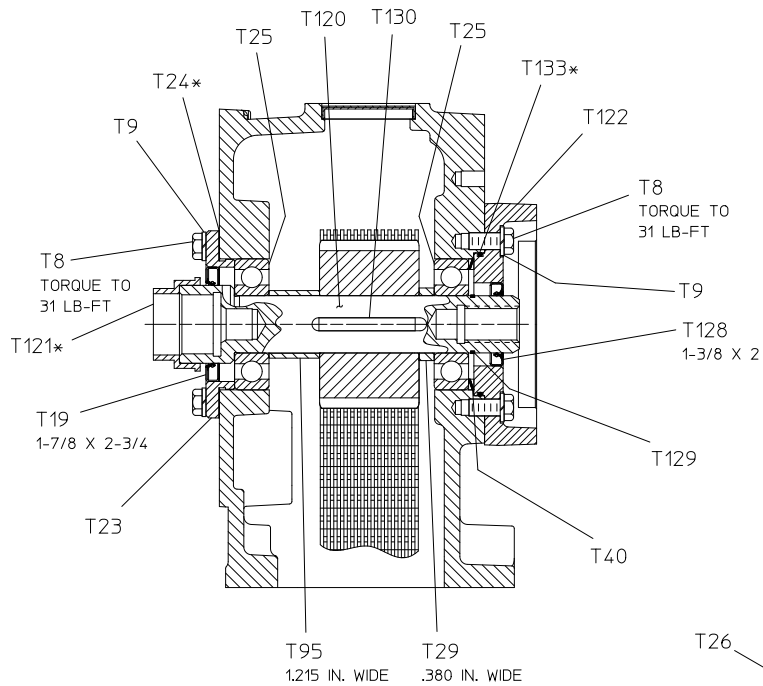

**OUTPUT SHAFT SIDE
(REAR)**

HYDRAULIC PUMP
NOT FURNISHED
BY WATEROUS

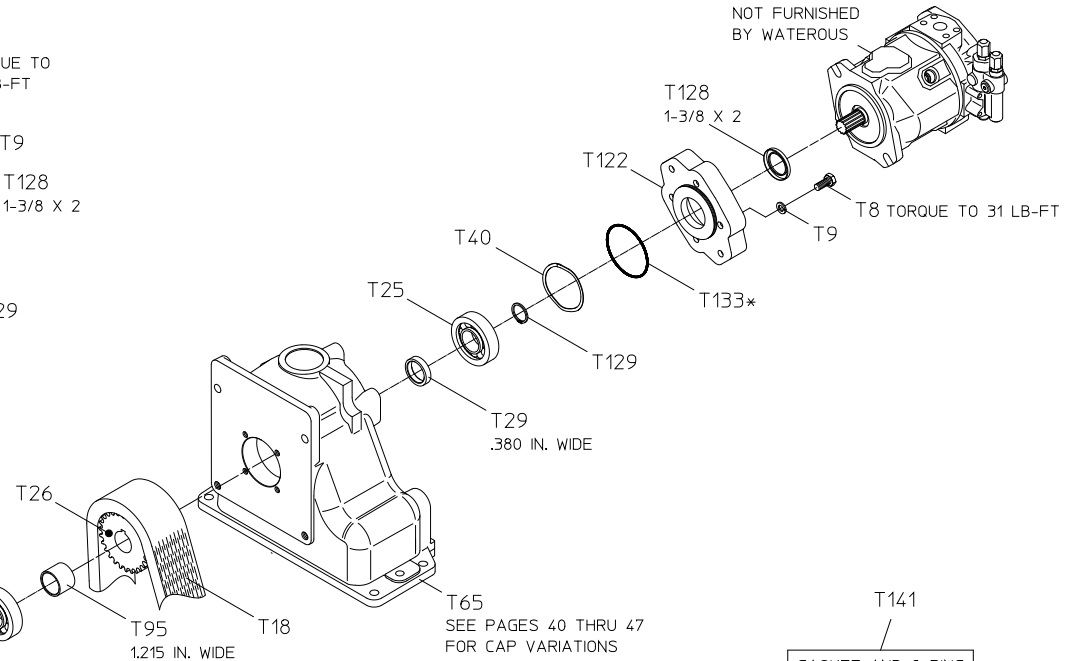

**INPUT SHAFT SIDE
(PUMP MOUNTING SIDE)**

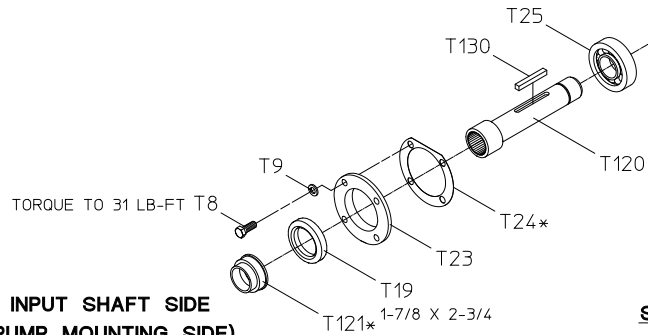

**DRIVEN SHAFT
SEPARABLE IMPELLER SHAFT**

PUMP MODELS: CM, CMU, CS, CSU

REAR OUTPUT CONFIGURATION: HYDRAULIC PUMP (SAE CLASS B 2-BOLT HYDRAULIC FLANGE)

Driven Shaft - Separable Impeller Shaft
Rear Output Configuration: Combination Pump

REF. NO.	DESCRIPTION
T8	Hex Hd Screw, 3/8-16 x 1 in.
T9	Lock Washer, 3/8 in.
T18	Chain
T19	Oil Seal, 1-7/8 x 2-3/4 x 5/16 in.
T23	Oil Seal Housing
T24	Oil Seal Housing Gasket
T25	Single Row Ball Bearing
T26	Driven Sprocket
T29	Bearing Spacer, .380 in. Wide
T32	Bearing Lock Nut Washer (W07)
T33	Bearing Lock Nut (N07)

REF. NO.	DESCRIPTION
T40	Wave Spring, 80 mm
T65	Case Cap
T95	Bearing Spacer, 1.215 Wide
T120	Driven Shaft
T121	Driven Shaft Boot
T123	Oil Seal Housing
T124	Oil Seal Sleeve
T130	Square Key, 5/16 x 2-5/16 in.
T133	O-ring, 3-1/4 x 3-7/16 in.
T141	Gasket and O-ring Repair Kit

Hardware Torque Specifications

Screw Size	Torque Specification
5/16-18 UNC	17 lb-ft
3/8-16 UNC	31 lb-ft
1/2-13 UNC	75 lb-ft
1/2-20 UNF	85 lb-ft
5/8-11 UNC	150 lb-ft

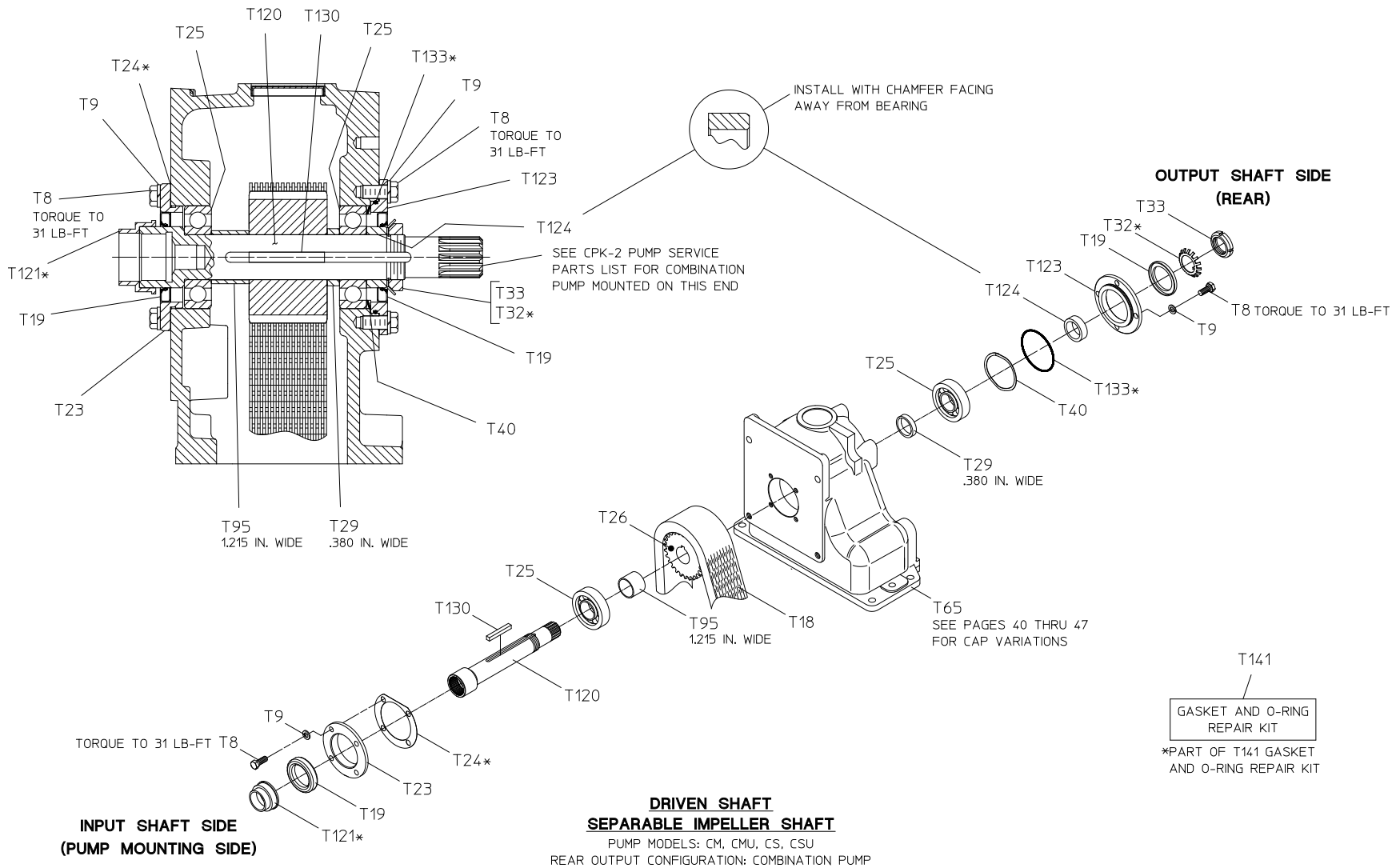

Driven Shaft - Separable Impeller Shaft

Rear Output Configuration: Oil Cooler

REF. NO.	DESCRIPTION
T8	Hex Hd Screw, 3/8-16 x 1 in.
T9	Lock Washer, 3/8 in.
T18	Chain
T19	Oil Seal, 1-7/8 x 2-3/4 x 5/16 in.
T20	Hex Hd Screw, 5/16-18 x 3-1/2 in.
T21	Lock Washer, 5/16 in.
T23	Oil Seal Housing
T24	Oil Seal Housing Gasket
T25	Single Row Ball Bearing
T26	Driven Sprocket
T29	Bearing Spacer, .380 in. Wide
T31	Oil Pump Housing
T32	Bearing Lock Nut Washer (W07)
T33	Bearing Lock Nut (N07)
T34	Oil Pump
T35	Oil Pump Gasket

REF. NO.	DESCRIPTION
T40	Wave Spring, 80 mm
T65	Case Cap
T95	Bearing Spacer, 1.215 Wide
T120	Driven Shaft
T121	Driven Shaft Boot
T130	Square Key, 5/16 x 2-5/16 in.
T133	O-ring, 3-1/4 x 3-7/16 in.
T141	Gasket and O-ring Repair Kit

Hardware Torque Specifications

Screw Size	Torque Specification
5/16-18 UNC	17 lb-ft
3/8-16 UNC	31 lb-ft
1/2-13 UNC	75 lb-ft
1/2-20 UNF	85 lb-ft
5/8-11 UNC	150 lb-ft

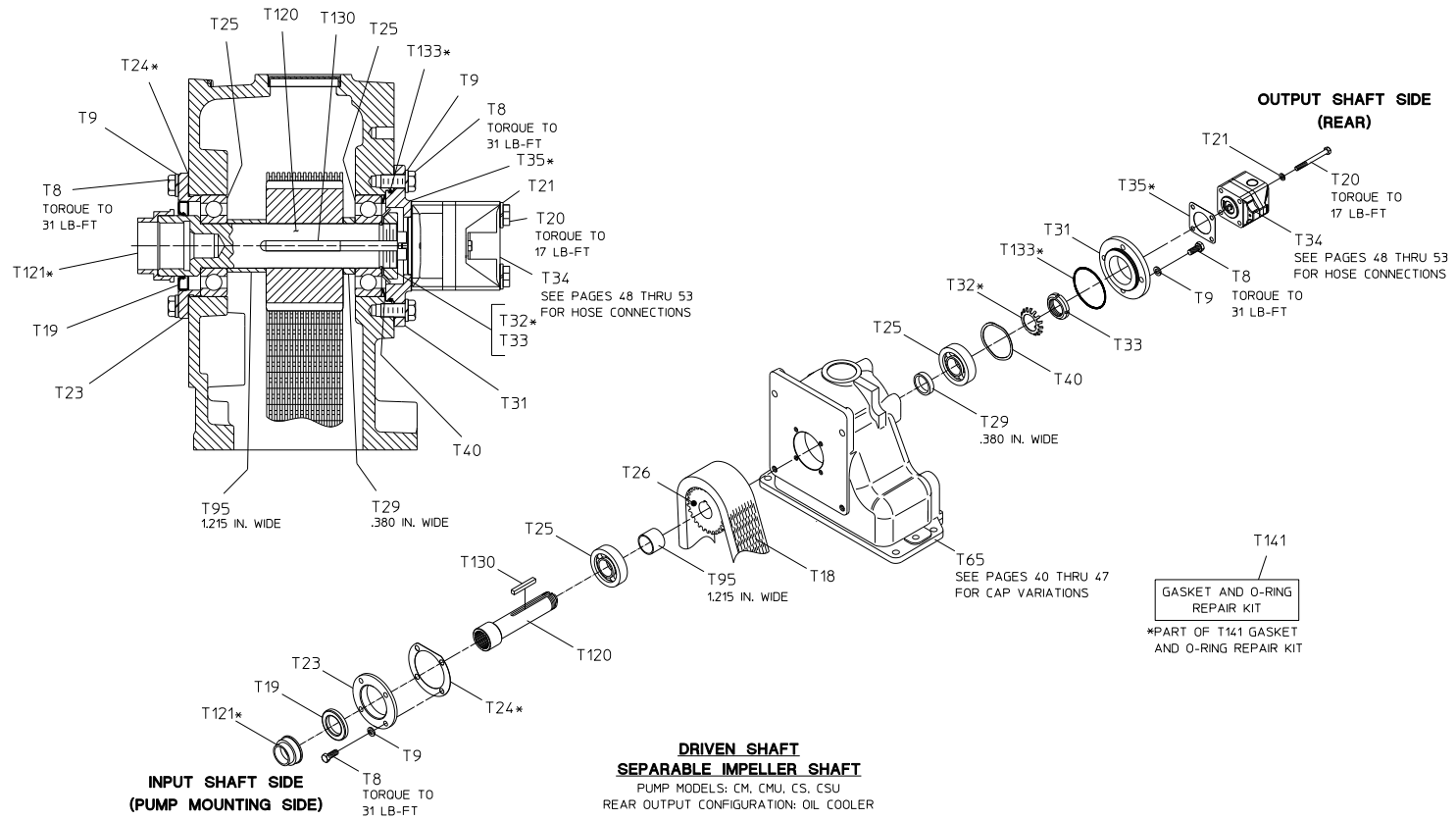

Driven Shaft - Non-Separable Impeller Shaft

Rear Output Configuration: None

REF. NO.	DESCRIPTION
T8	Hex Hd Screw, 3/8-16 x 1 in.
T9	Lock Washer, 3/8 in.
T18	Chain
T19	Oil Seal, 1-5/8 x 2-1/2 x 5/16 in.
T23	Oil Seal Housing
T24	Oil Seal Housing Gasket
T25	Single Row Ball Bearing
T26	Driven Sprocket
T29	Bearing Spacer, .380 in. Wide
T31	Bearing Cover
T32	Bearing Lock Nut Washer (W07)
T33	Bearing Lock Nut (N07)

REF. NO.	DESCRIPTION
T40	Wave Spring, 80 mm
T65	Case Cap
T95	Bearing Spacer, 1.265 Wide
T125	Double Row Ball Bearing
T133	O-ring, 3-1/4 x 3-7/16 in.
T141	Gasket and O-ring Repair Kit

Hardware Torque Specifications

Screw Size	Torque Specification
5/16-18 UNC	17 lb-ft
3/8-16 UNC	31 lb-ft
1/2-13 UNC	75 lb-ft
1/2-20 UNF	85 lb-ft
5/8-11 UNC	150 lb-ft

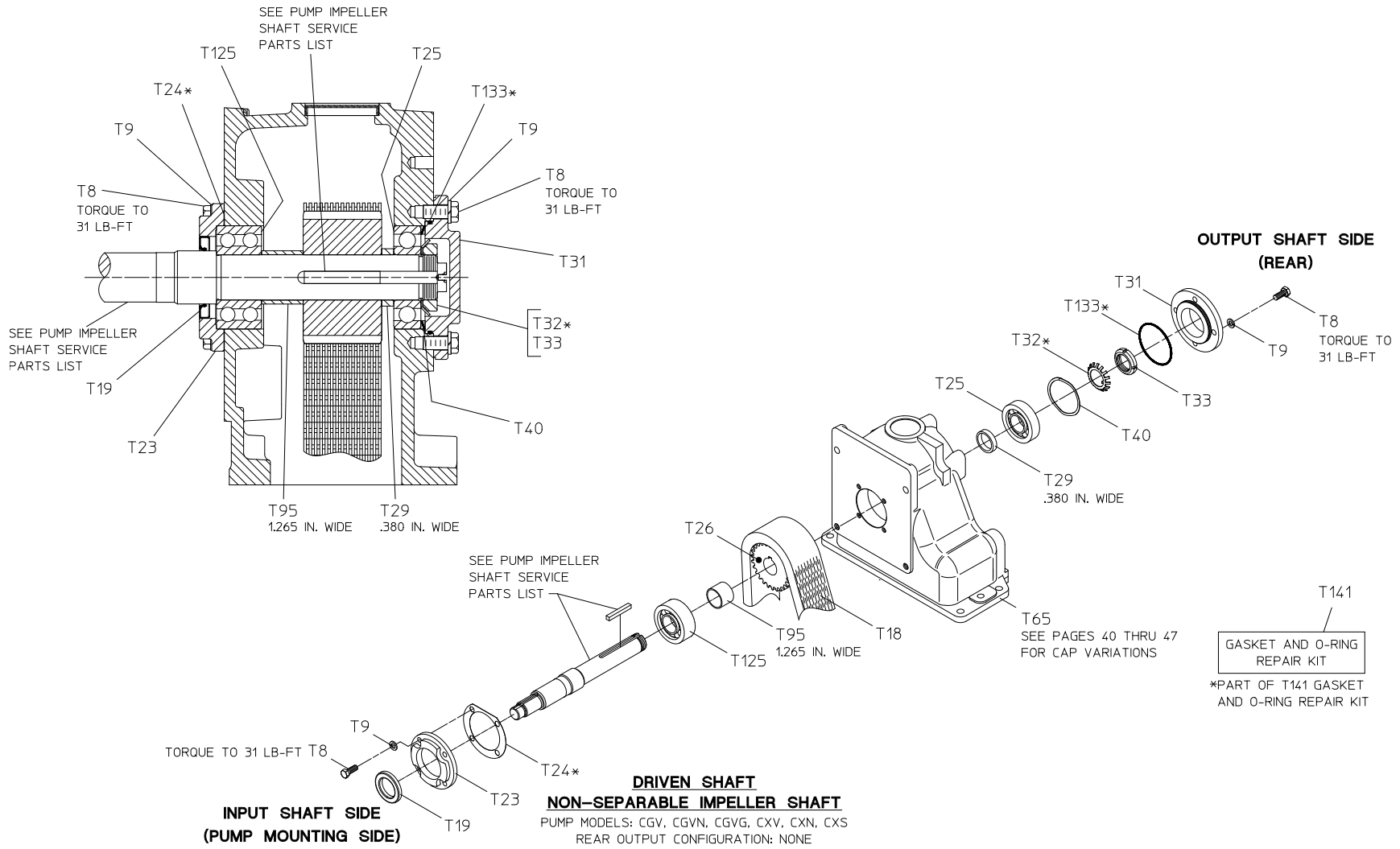

Driven Shaft - Non-Separable Impeller Shaft

Rear Output Configuration: Eclipse ES, 150-ESD, 150-ESOS CAFS

REF. NO.	DESCRIPTION
T8	Hex Hd Screw, 3/8-16 x 1 in.
T9	Lock Washer, 3/8 in.
T18	Chain
T19	Oil Seal, 1-5/8 x 2-1/2 x 5/16 in.
T23	Oil Seal Housing
T24	Oil Seal Housing Gasket
T25	Single Row Ball Bearing
T26	Driven Sprocket
T29	Bearing Spacer, .380 in. Wide
T31	Bearing Cover

REF. NO.	DESCRIPTION
T40	Wave Spring, 80 mm
T65	Case Cap
T95	Bearing Spacer, 1.265 Wide
T125	Double Row Ball Bearing
T127	Oil Seal, 1-3/8 x 2-5/8 x 5/16 in.
T129	Retaining Ring
T133	O-ring, 3-1/4 x 3-7/16 in.
T141	Gasket and O-ring Repair Kit

Hardware Torque Specifications

Screw Size	Torque Specification
5/16-18 UNC	17 lb-ft
3/8-16 UNC	31 lb-ft
1/2-13 UNC	75 lb-ft
1/2-20 UNF	85 lb-ft
5/8-11 UNC	150 lb-ft

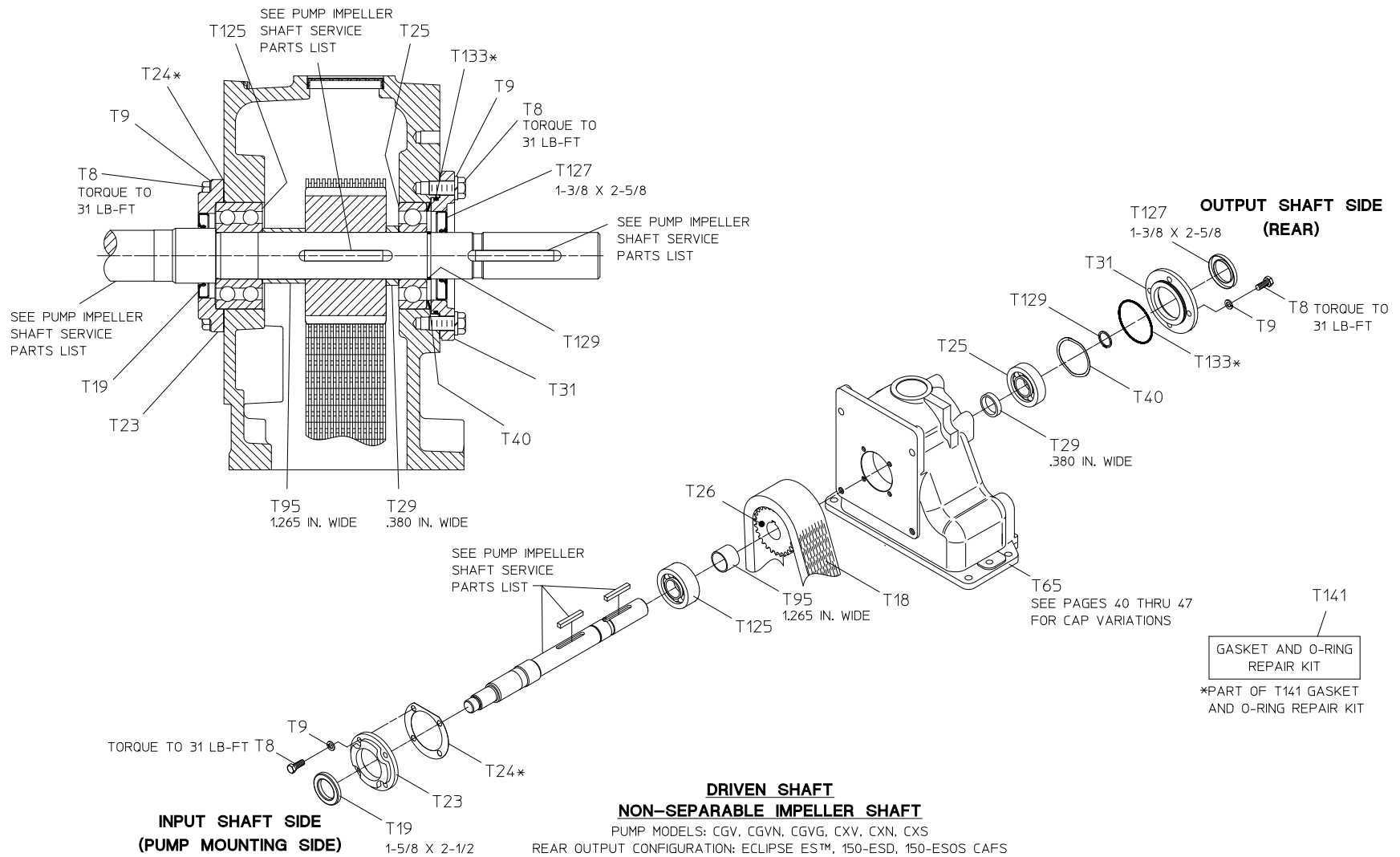

Driven Shaft - Separable Impeller Shaft
Rear Output Configuration: Hydraulic Pump

REF. NO.	DESCRIPTION
T8	Hex Hd Screw, 3/8-16 x 1 in.
T9	Lock Washer, 3/8 in.
T18	Chain
T19	Oil Seal, 1-5/8 x 2-1/2 x 5/16 in.
T23	Oil Seal Housing
T24	Oil Seal Housing Gasket
T25	Single Row Ball Bearing
T26	Driven Sprocket
T29	Bearing Spacer, .380 in. Wide
T32	Bearing Lock Washer
T33	Bearing Lock Nut

REF. NO.	DESCRIPTION
T40	Wave Spring, 80 mm
T65	Case Cap
T95	Bearing Spacer, 1.615 Wide
T122	Hydraulic Adapter, SAE Class B 2-Bolt
T125	Double Row Ball Bearing
T128	Oil Seal, 1-1/4 x 2 x 1/4 in.
T133	O-ring, 3-1/4 x 3-7/16 in.
T141	Gasket and O-ring Repair Kit

Hardware Torque Specifications

Screw Size	Torque Specification
5/16-18 UNC	17 lb-ft
3/8-16 UNC	31 lb-ft
1/2-13 UNC	75 lb-ft
1/2-20 UNF	85 lb-ft
5/8-11 UNC	150 lb-ft

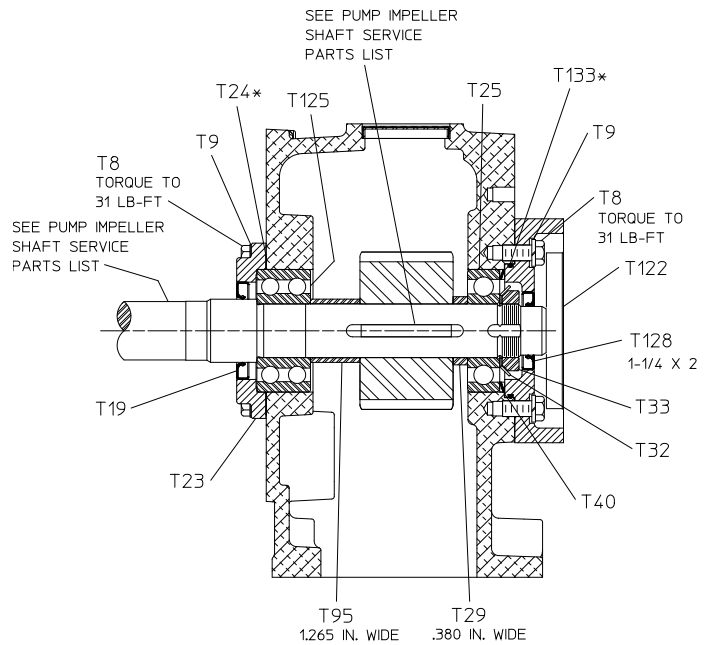

OUTPUT SHAFT SIDE (REAR)

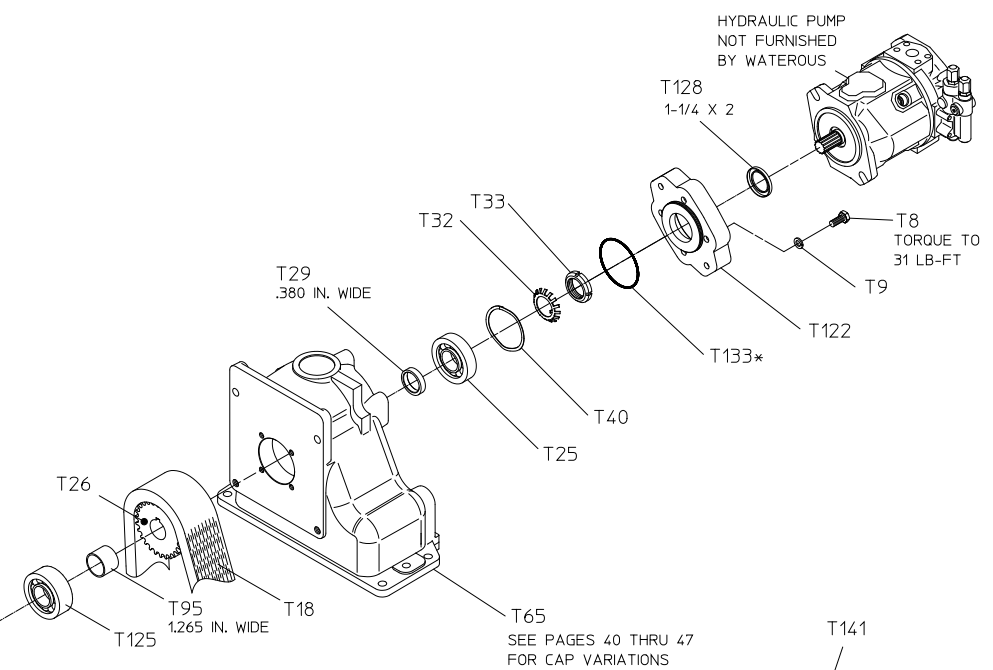

T141
GASKET AND O-RING REPAIR KIT

*PART OF T141 GASKET AND O-RING REPAIR KIT

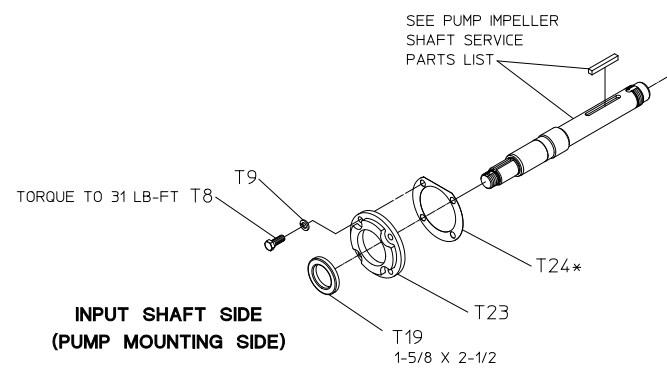

INPUT SHAFT SIDE (PUMP MOUNTING SIDE)

DRIVEN SHAFT NON-SEPARABLE IMPELLER SHAFT

PUMP MODELS: CXV, CXS, CXN
REAR OUTPUT CONFIGURATION: HYDRAULIC PUMP (SAE CLASS B 2-BOLT HYDRAULIC FLANGE)

Driven Shaft - Non-Separable Impeller Shaft

Rear Output Configuration: None

REF. NO.	DESCRIPTION
T8	Hex Hd Screw, 3/8-16 x 1 in.
T9	Lock Washer, 3/8 in.
T18	Chain
T19	Oil Seal, 1-5/8 x 2-3/4 x 1/4 in.
T23	Oil Seal Housing
T24	Oil Seal Housing Gasket
T25	Single Row Ball Bearing
T26	Driven Sprocket
T29	Bearing Spacer, .392 in. Wide
T31	Bearing Cover
T32	Bearing Lock Nut Washer (W07)
T33	Bearing Lock Nut (N07)

REF. NO.	DESCRIPTION
T40	Wave Spring, 80 mm
T65	Case Cap
T95	Bearing Spacer, 1.215 Wide
T133	O-ring, 3-1/4 x 3-7/16 in.
T141	Gasket and O-ring Repair Kit

Hardware Torque Specifications

Screw Size	Torque Specification
5/16-18 UNC	17 lb-ft
3/8-16 UNC	31 lb-ft
1/2-13 UNC	75 lb-ft
1/2-20 UNF	85 lb-ft
5/8-11 UNC	150 lb-ft

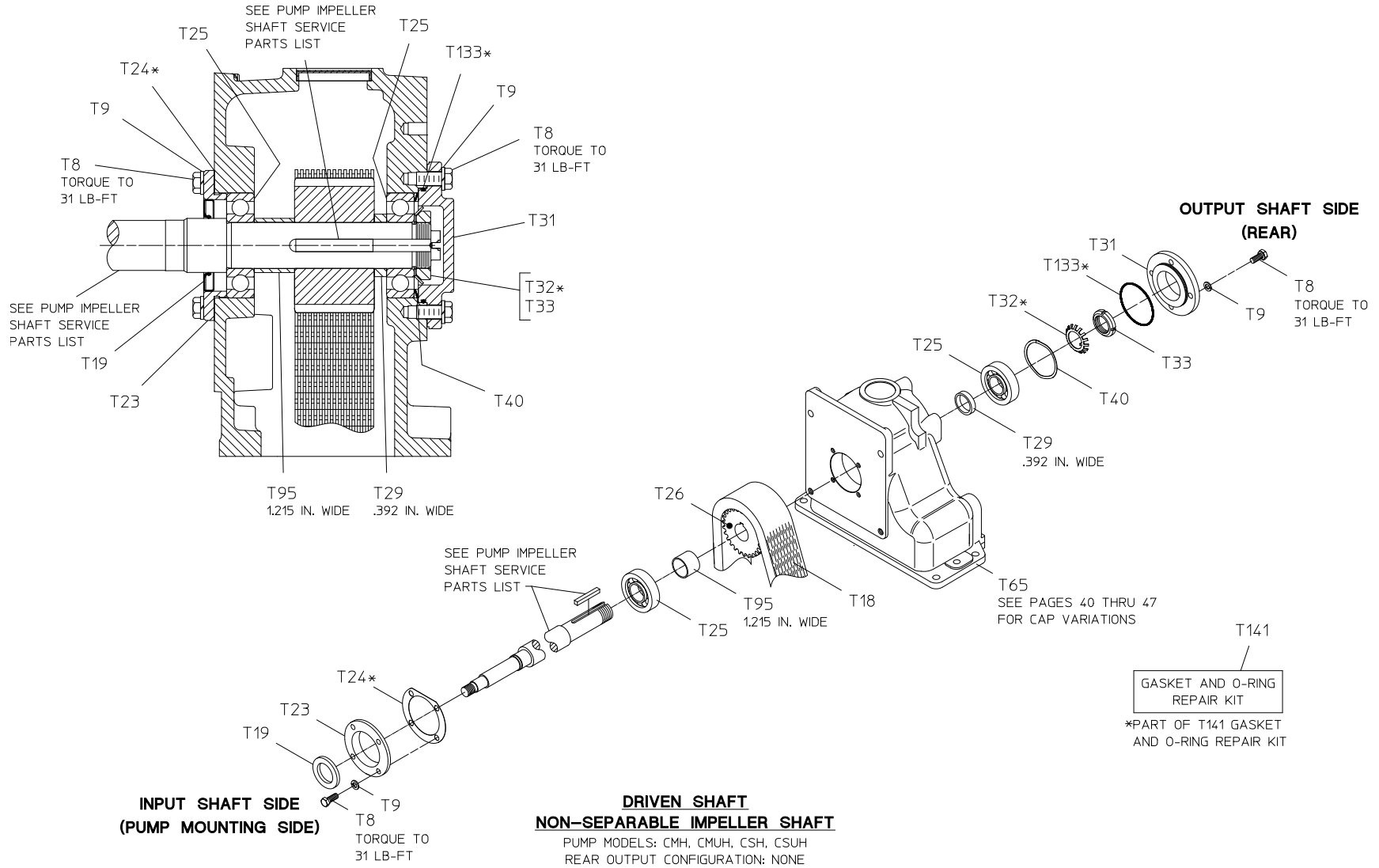

Standard Driveline - Input and Output Shafts

Exploded View

REF. NO.	DESCRIPTION
T2	Coupling Shaft Spacer
T3	Single Row Ball Bearing
T4	Shift Collar
T5	Drive Sprocket
T6	Needle Bearing
T7	Thrust Washer
T8	Hex Hd Screw, 3/8-16 x 1 in.
T9	Lock Washer, 3/8 in.
T10	Tachometer Pulse Generator
T11	Drive Shaft Housing
T12	O-ring, 4-3/4 x 5 in.
T13	Drive Shaft
T14	Oil Seal, 3-1/2 x 4-3/8 in.
T15	Single Row Ball Bearing
T18	Chain
T26	Driven Sprocket
T36	Retaining Ring (Used Starting August 3, 2012)
T41	Wave Spring, 110 mm

REF. NO.	DESCRIPTION
T42	Coupling Shaft Housing
T43	Self-Locking Nut, 1-1/4-18 in.
T44	Coupling Shaft (Includes T36)
T46	Shoulder Screw, 5.8-11 x 2-1/2 in. (Self-Locking)
T68	Set Screw, 5/8-18 x 5/8 in.
T75	Shift Shoe
T80	Shift Fork
T83	Chain Connecting Pin Set
T94	Plain Washer, 1-1/4 in.
T108	Spirol Pin, 1/16 x 1/4 or 1/16 x 5/16 in.
T110	Magnetic Tachometer Pick-up
T111	O-ring, 5/8 x 3/4 in.
T141	Gasket and O-ring Repair Kit
T142	Aluminum Shim

Hardware Torque Specifications

Screw Size	Torque Specification
5/16-18 UNC	17 lb-ft
3/8-16 UNC	31 lb-ft
1/2-13 UNC	75 lb-ft
1/2-20 UNF	85 lb-ft
5/8-11 UNC	150 lb-ft

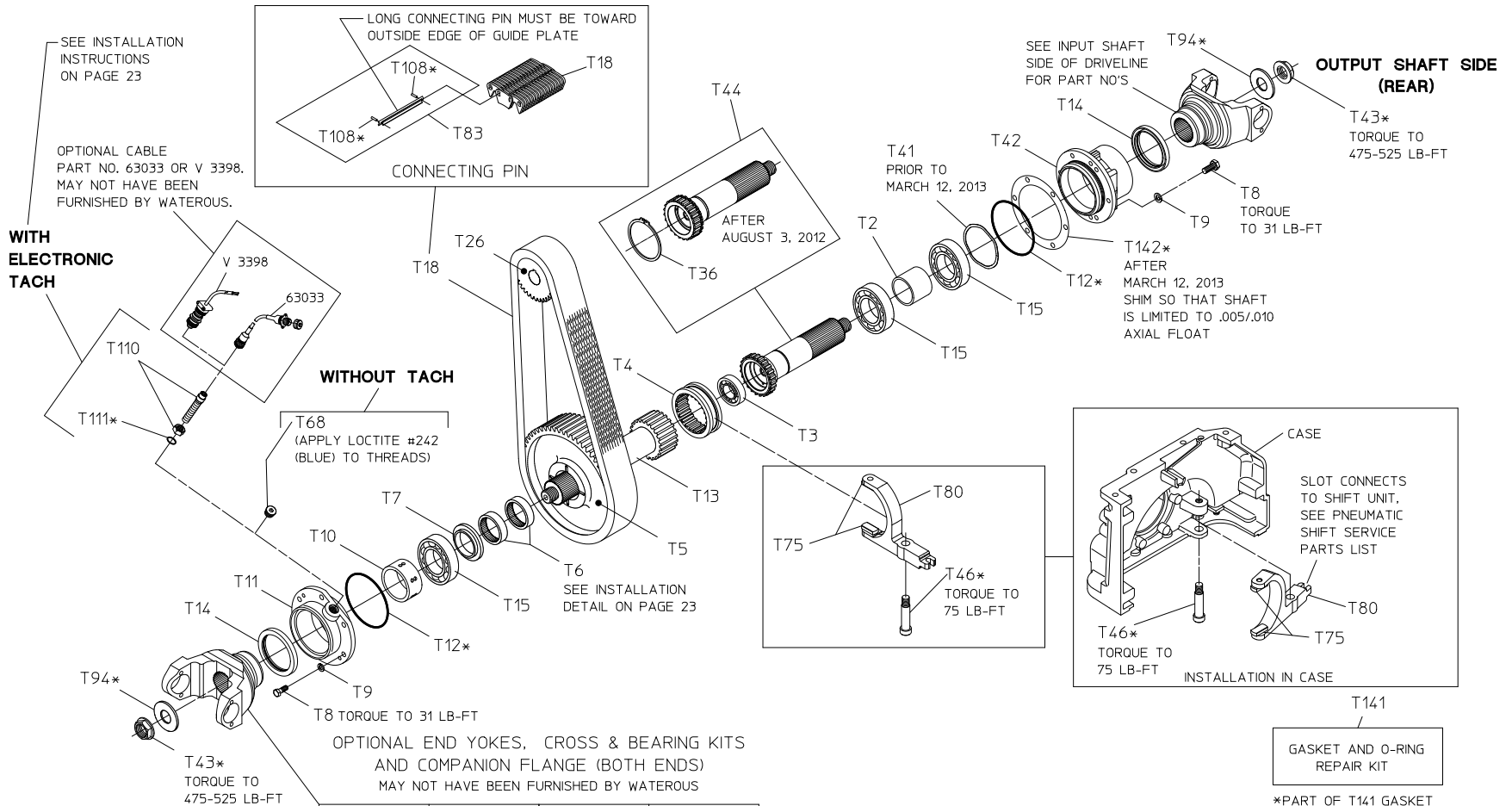

TYPE	SERIES	PART NO.	CROSS & BRG KIT NO.
END YOKE	1710 BP	V 2837	V 2839
	1810 BP	V 2838	V 2840
	1710 HR	V 4101	-
	1810 HR	V 4102	-
	SPL140	V 3388	V 3389
COMPANION FLANGE	1650/1710	V 3619	-
	1480/1610	V 3719	-
	ISO 8667	63714	-

STANDARD DRIVELINE
INPUT AND OUTPUT SHAFTS

Standard Driveline - Input and Output Shafts

Cross-Section View

REF. NO.	DESCRIPTION
T2	Coupling Shaft Spacer
T3	Single Row Ball Bearing
T4	Shift Collar
T5	Drive Sprocket
T6	Needle Bearing
T7	Thrust Washer
T8	Hex Hd Screw, 3/8-16 x 1 in.
T9	Lock Washer, 3/8 in.
T10	Tachometer Pulse Generator
T11	Drive Shaft Housing
T12	O-ring, 4-3/4 x 5 in.
T13	Drive Shaft
T14	Oil Seal, 3-1/2 x 4-3/8 in.
T15	Single Row Ball Bearing
T18	Chain
T26	Driven Sprocket
T36	Retaining Ring (Used Starting August 3, 2012)
T41	Wave Spring, 110 mm

REF. NO.	DESCRIPTION
T42	Coupling Shaft Housing
T43	Self-Locking Nut, 1-1/4-18 in.
T44	Coupling Shaft (Includes T36)
T46	Shoulder Screw, 5.8-11 x 2-1/2 in. (Self-Locking)
T68	Set Screw, 5/8-18 x 5/8 in.
T75	Shift Shoe
T80	Shift Fork
T94	Plain Washer, 1-1/4 in.
T110	Magnetic Tachometer Pick-up
T111	O-ring, 5/8 x 3/4 in.
T141	Gasket and O-ring Repair Kit
T142	Aluminum Shim

Hardware Torque Specifications

Screw Size	Torque Specification
5/16-18 UNC	17 lb-ft
3/8-16 UNC	31 lb-ft
1/2-13 UNC	75 lb-ft
1/2-20 UNF	85 lb-ft
5/8-11 UNC	150 lb-ft

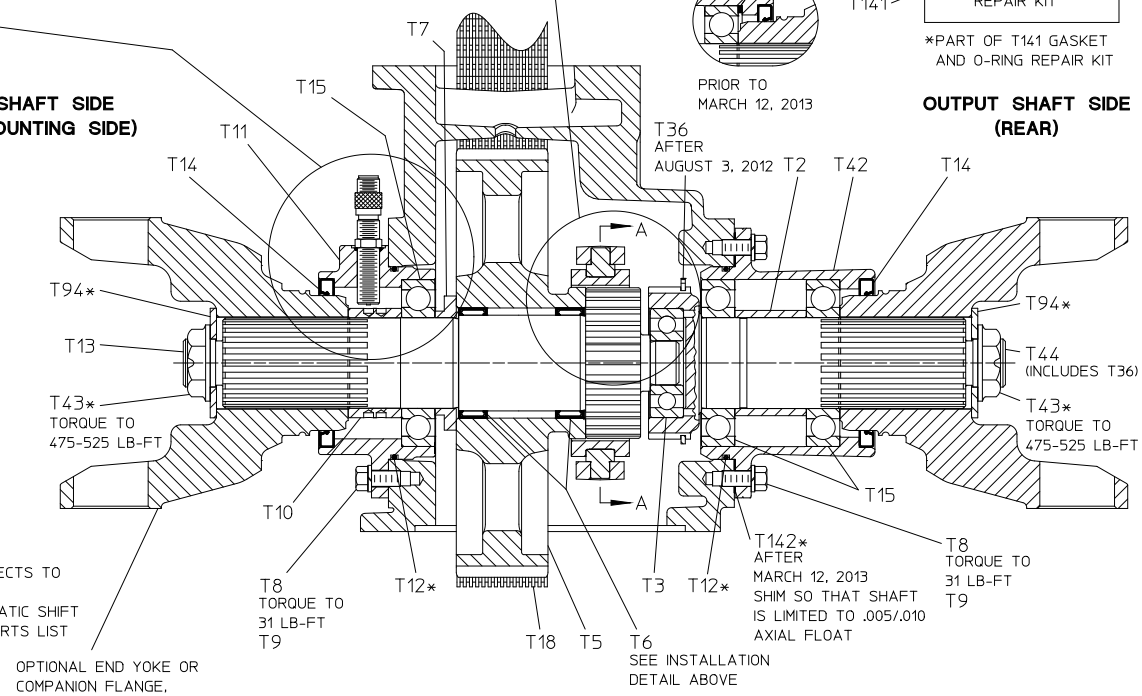
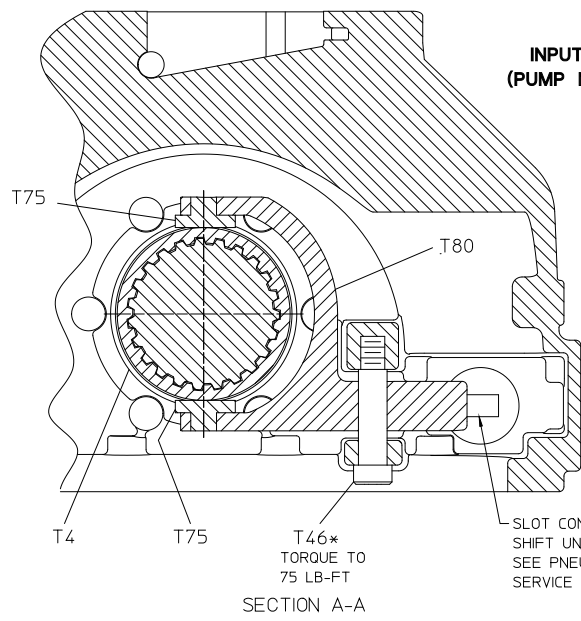
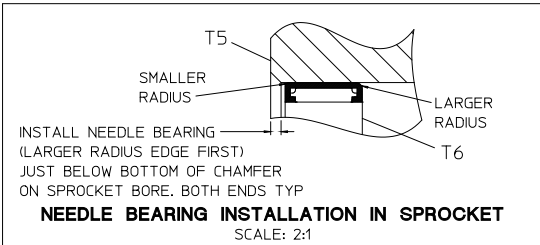
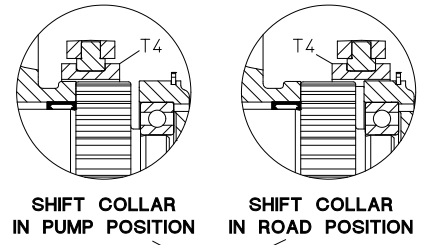
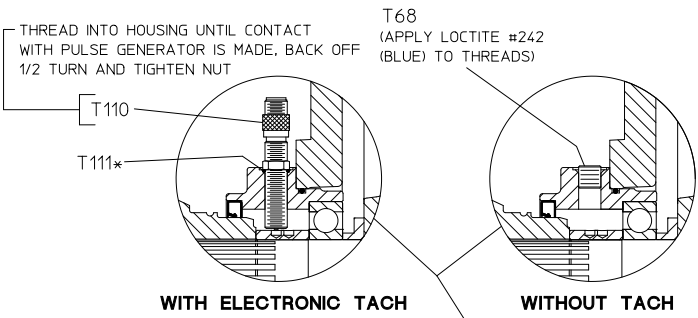

OPTIONAL END YOKE OR COMPANION FLANGE. SEE PAGE 21 FOR PART NO'S MAY NOT HAVE BEEN FURNISHED BY WATEROUS

STANDARD DRIVELINE
INPUT AND OUTPUT SHAFTS

Standard Driveline - Input Shaft Only

Exploded View

REF. NO.	DESCRIPTION
T3	Single Row Ball Bearing
T4	Shift Collar
T5	Drive Sprocket
T6	Needle Bearing
T7	Thrust Washer
T8	Hex Hd Screw, 3/8-16 x 1 in.
T9	Lock Washer, 3/8 in.
T10	Tachometer Pulse Generator
T11	Drive Shaft Housing
T12	O-ring, 4-3/4 x 5 in.
T13	Drive Shaft
T14	Oil Seal, 3-1/2 x 4-3/8 in.
T15	Single Row Ball Bearing
T18	Chain
T26	Driven Sprocket
T36	Retaining Ring
T41	Wave Spring, 72 mm

REF. NO.	DESCRIPTION
T42	Bearing Housing
T43	Self-Locking Nut, 1-1/4-18 in.
T68	Set Screw, 5/8-18 x 5/8 in.
T83	Chain Connecting Pin Set
T94	Plain Washer, 1-1/4 in.
T108	Spirol Pin, 1/16 x 1/4 or 1/16 x 5/16 in.
T110	Magnetic Tachometer Pick-up
T111	O-ring, 5/8 x 3/4 in.
T141	Gasket and O-ring Repair Kit

Hardware Torque Specifications

Screw Size	Torque Specification
5/16-18 UNC	17 lb-ft
3/8-16 UNC	31 lb-ft
1/2-13 UNC	75 lb-ft
1/2-20 UNF	85 lb-ft
5/8-11 UNC	150 lb-ft

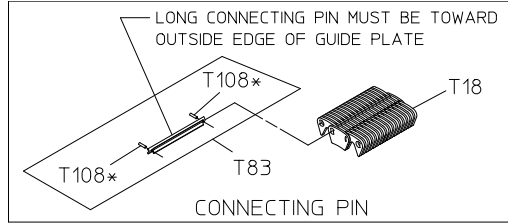

WITH ELECTRONIC TACH

SEE INSTALLATION INSTRUCTIONS ON PAGE 27

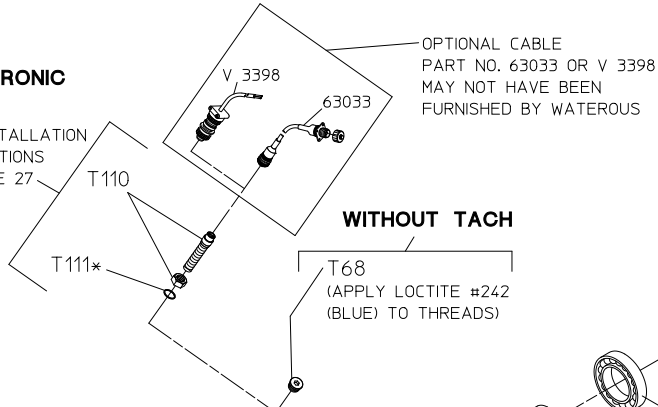

WITHOUT TACH

T68 (APPLY LOCTITE #242 (BLUE) TO THREADS)

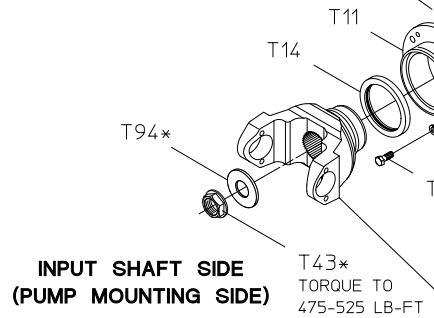

INPUT SHAFT SIDE (PUMP MOUNTING SIDE)

OPTIONAL END YOKES, CROSS & BEARING KITS AND COMPANION FLANGE (BOTH ENDS) MAY NOT HAVE BEEN FURNISHED BY WATEROUS

TYPE	SERIES	PART NO.	CROSS & BRG KIT NO.
END YOKE	1710 BP	V 2837	V 2839
	1810 BP	V 2838	V 2840
	1710 HR	V 4101	-
	1810 HR	V 4102	-
	SPL140	V 3388	V 3389
COMPANION FLANGE	1650/1710	V 3619	-
	1480/1610	V 3719	-
	ISO 8667	63714	-

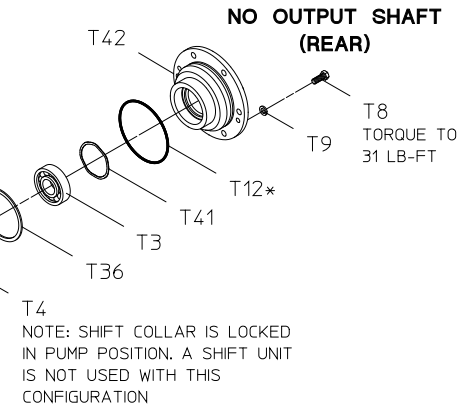
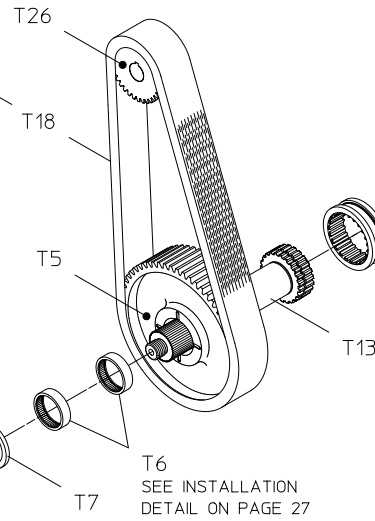

NO OUTPUT SHAFT (REAR)

STANDARD DRIVELINE
INPUT SHAFT ONLY

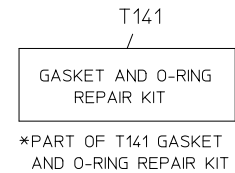

Standard Driveline - Input Shaft Only

Cross-Section View

REF. NO.	DESCRIPTION
T3	Single Row Ball Bearing
T4	Shift Collar
T5	Drive Sprocket
T6	Needle Bearing
T7	Thrust Washer
T8	Hex Hd Screw, 3/8-16 x 1 in.
T9	Lock Washer, 3/8 in.
T10	Tachometer Pulse Generator
T11	Drive Shaft Housing
T12	O-ring, 4-3/4 x 5 in.
T13	Drive Shaft
T14	Oil Seal, 3-1/2 x 4-3/8 in.
T15	Single Row Ball Bearing
T18	Chain
T36	Retaining Ring
T41	Wave Spring, 72 mm

REF. NO.	DESCRIPTION
T42	Bearing Housing
T43	Self-Locking Nut, 1-1/4-18 in.
T68	Set Screw, 5/8-18 x 5/8 in.
T94	Plain Washer, 1-1/4 in.
T110	Magnetic Tachometer Pick-up
T111	O-ring, 5/8 x 3/4 in.
T141	Gasket and O-ring Repair Kit

Hardware Torque Specifications

Screw Size	Torque Specification
5/16-18 UNC	17 lb-ft
3/8-16 UNC	31 lb-ft
1/2-13 UNC	75 lb-ft
1/2-20 UNF	85 lb-ft
5/8-11 UNC	150 lb-ft

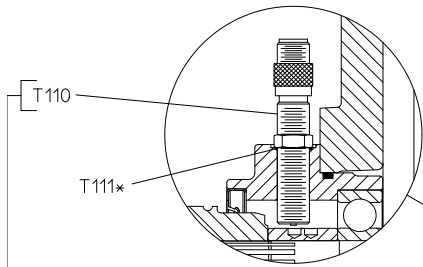

WITH ELECTRONIC TACH

— THREAD INTO HOUSING UNTIL CONTACT WITH PULSE GENERATOR IS MADE. BACK OFF 1/2 TURN AND TIGHTEN NUT

T68
(APPLY LOCTITE #242 (BLUE) TO THREADS)

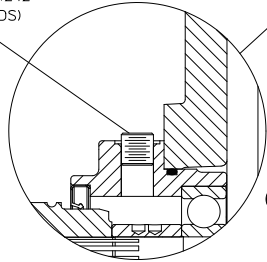

WITHOUT TACH

T141
GASKET AND O-RING REPAIR KIT
*PART OF T141 GASKET AND O-RING REPAIR KIT

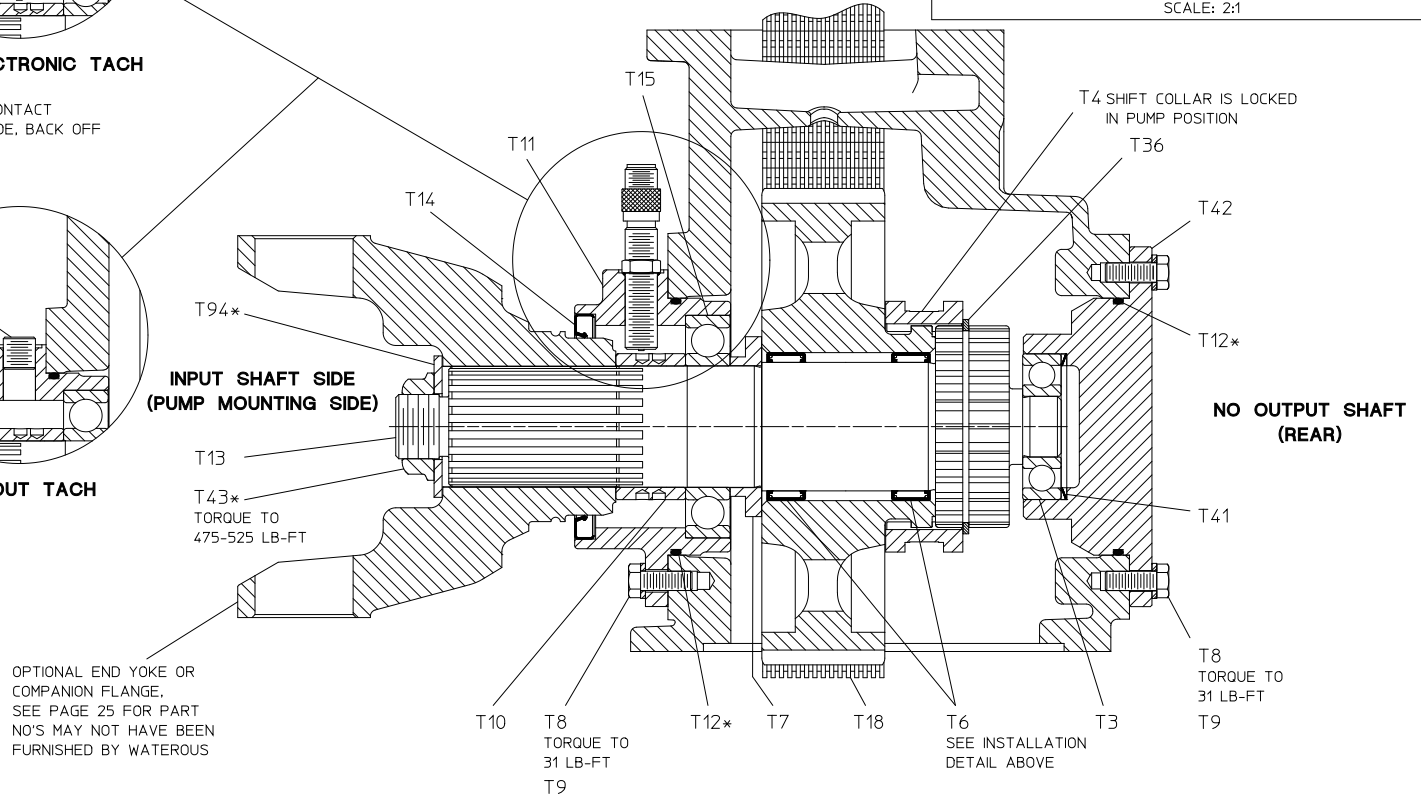
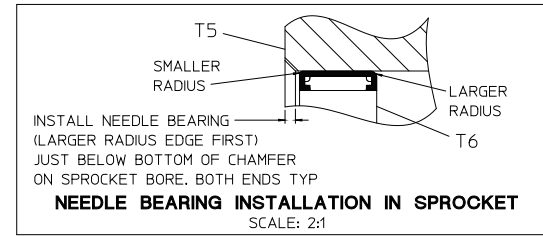

STANDARD DRIVELINE
INPUT SHAFT ONLY

High Speed Driveline - Input and Output Shafts

Exploded View

REF. NO.	DESCRIPTION
T2	Coupling Shaft Spacer
T3	Single Row Ball Bearing
T4	Shift Collar
T5	Drive Sprocket
T6	Bal Bearing
T8	Hex Hd Screw, 3/8-16 x 1 in.
T9	Lock Washer, 3/8 in.
T10	Tachometer Pulse Generator
T11	Drive Shaft Housing
T12	O-ring, 4-3/4 x 5 in.
T13	Drive Shaft
T14	Oil Seal, 3-1/2 x 4-3/8 in.
T15	Single Row Ball Bearing
T18	Chain
T26	Driven Sprocket
T36	Retaining Ring

REF. NO.	DESCRIPTION
T42	Coupling Shaft Housing
T43	Self-Locking Nut, 1-1/4-18 in.
T44	Coupling Shaft (Includes T36)
T46	Shoulder Screw, 5.8-11 x 2-1/2 in. (Self-Locking)
T68	Set Screw, 5/8-18 x 5/8 in.
T75	Shift Shoe
T80	Shift Fork
T83	Chain Connecting Pin Set
T94	Plain Washer, 1-1/4 in.
T108	Spirol Pin, 1/16 x 1/4 or 1/16 x 5/16 in.
T110	Magnetic Tachometer Pick-up
T111	O-ring, 5/8 x 3/4 in.
T141	Gasket and O-ring Repair Kit
T142	Aluminum Shim
T165	Spacer-Driveline
T166	Spacer-Driveline
T167	Ring-Retaining

Hardware Torque Specifications

Screw Size	Torque Specification
5/16-18 UNC	17 lb-ft
3/8-16 UNC	31 lb-ft
1/2-13 UNC	75 lb-ft
1/2-20 UNF	85 lb-ft
5/8-11 UNC	150 lb-ft

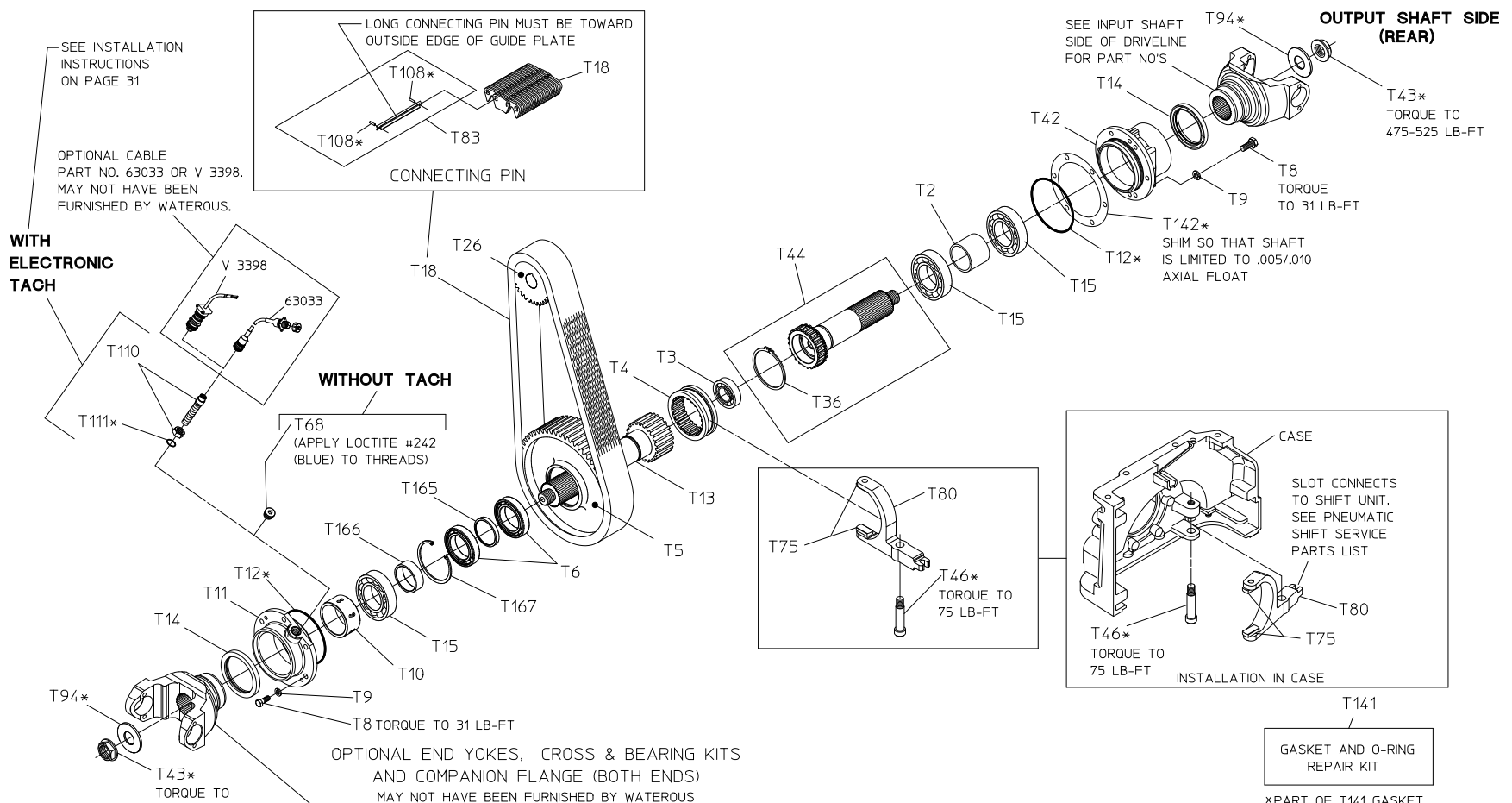

**INPUT SHAFT SIDE
(PUMP MOUNTING SIDE)**

OPTIONAL END YOKE, CROSS & BEARING KITS AND COMPANION FLANGE (BOTH ENDS) MAY NOT HAVE BEEN FURNISHED BY WATEROUS

TYPE	SERIES	PART NO.	CROSS & BRG KIT NO.
END YOKE	1710 BP	V 2837	V 2839
	1810 BP	V 2838	V 2840
	1710 HR	V 4101	-
	1810 HR	V 4102	-
	SPL140	V 3388	V 3389
COMPANION FLANGE	1650/1710	V 3619	-
	1480/1610	V 3719	-
	ISO 8667	63714	-

HIGH SPEED DRIVELINE
INPUT AND OUTPUT SHAFTS

High Speed Driveline - Input and Output Shafts

Cross-Section View

REF. NO.	DESCRIPTION
T2	Coupling Shaft Spacer
T3	Single Row Ball Bearing
T4	Shift Collar
T5	Drive Sprocket
T6	Ball Bearing
T8	Hex Hd Screw, 3/8-16 x 1 in.
T9	Lock Washer, 3/8 in.
T10	Tachometer Pulse Generator
T11	Drive Shaft Housing
T12	O-ring, 4-3/4 x 5 in.
T13	Drive Shaft
T14	Oil Seal, 3-1/2 x 4-3/8 in.
T15	Single Row Ball Bearing
T18	Chain
T26	Driven Sprocket
T36	Retaining Ring

REF. NO.	DESCRIPTION
T42	Coupling Shaft Housing
T43	Self-Locking Nut, 1-1/4-18 in.
T44	Coupling Shaft (Includes T36)
T46	Shoulder Screw, 5.8-11 x 2-1/2 in. (Self-Locking)
T68	Set Screw, 5/8-18 x 5/8 in.
T75	Shift Shoe
T80	Shift Fork
T94	Plain Washer, 1-1/4 in.
T110	Magnetic Tachometer Pick-up
T111	O-ring, 5/8 x 3/4 in.
T141	Gasket and O-ring Repair Kit
T142	Aluminum Shim
T165	Spacer-Driveline
T166	Spacer-Driveline
T177	Ring-Retaining

Hardware Torque Specifications

Screw Size	Torque Specification
5/16-18 UNC	17 lb-ft
3/8-16 UNC	31 lb-ft
1/2-13 UNC	75 lb-ft
1/2-20 UNF	85 lb-ft
5/8-11 UNC	150 lb-ft

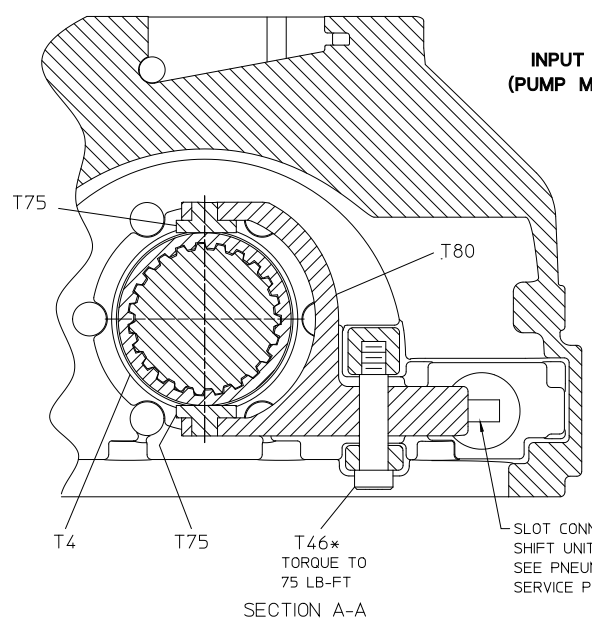
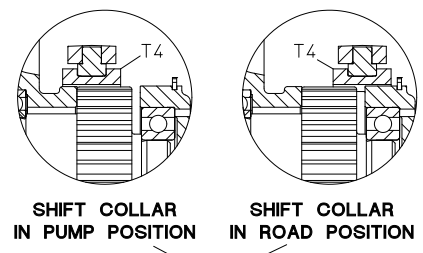
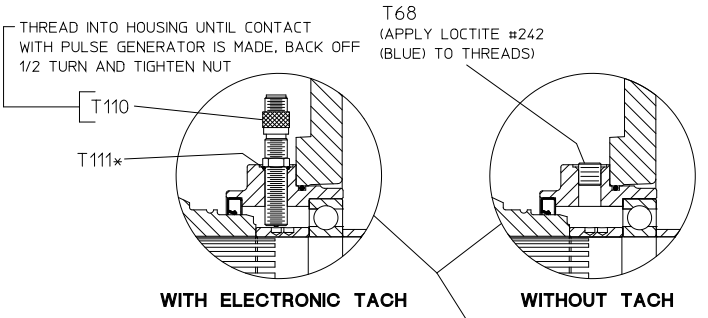

INPUT SHAFT SIDE
(PUMP MOUNTING SIDE)

SLOT CONNECTS TO SHIFT UNIT. SEE PNEUMATIC SHIFT SERVICE PARTS LIST

OPTIONAL END YOKE OR COMPANION FLANGE. SEE PAGE 29 FOR PART NO'S MAY NOT HAVE BEEN FURNISHED BY WATEROUS

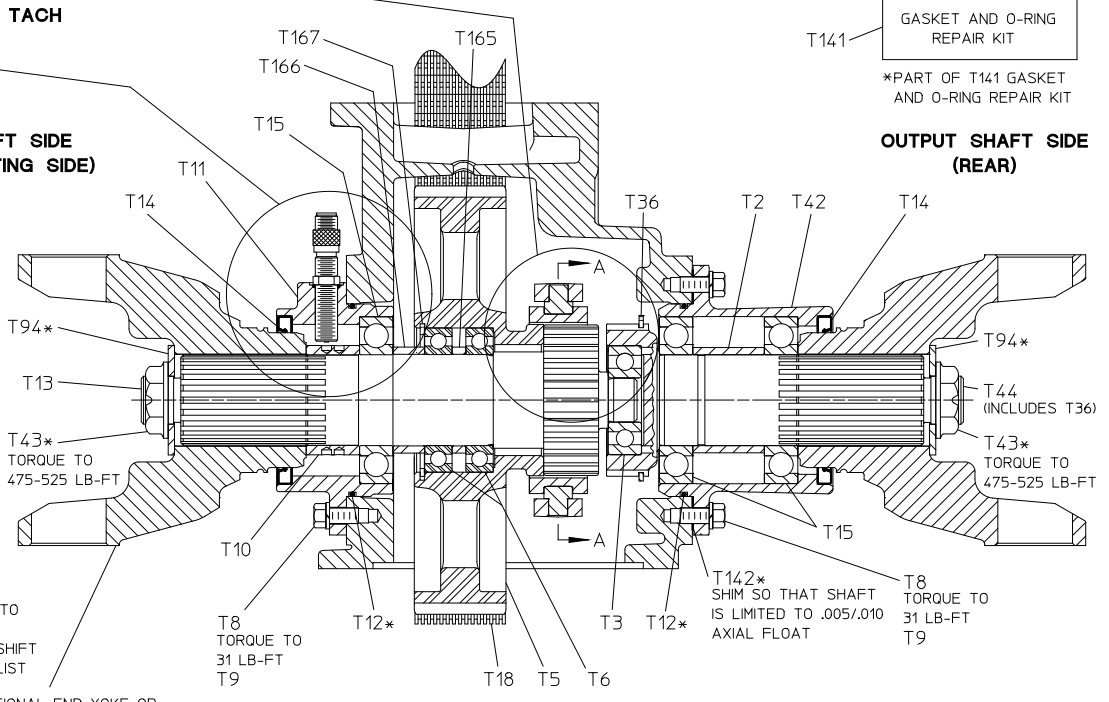

OUTPUT SHAFT SIDE
(REAR)

HIGH SPEED DRIVELINE
INPUT AND OUTPUT SHAFTS

Case
Viewed from Input Side

REF. NO.	DESCRIPTION
T8	Hex Hd Screw, 3/8-16 x 1 in.
T9	Lock Washer, 3/8 in.
T16	Transmission Pan
T17	Transmission Pan, O-ring 13 x 13-3/8
T27	Breather, 1/2 NPT
T28	Case
T51	Hex Hd Screw, 1/2-13 x 1-1/2 in.
T52	Stud, 1/2-13 x 2-1/4 in.
T53	Lock Washer, 1/2 in.

REF. NO.	DESCRIPTION
T69	Hex Nut, 1/2-20
T72	Hex Hd Screw, 1/2-20 x 2-1/4 in.
T81	Pipe Nipple, 1/2 NPT x 1-1/2 in.
T82	Coupling, 1/2 NPT
T141	Gasket and O-ring Repair Kit
T164	Hex Nut, 1/2-13

Hardware Torque Specifications

Screw Size	Torque Specification
5/16-18 UNC	17 lb-ft
3/8-16 UNC	31 lb-ft
1/2-13 UNC	75 lb-ft
1/2-20 UNF	85 lb-ft
5/8-11 UNC	150 lb-ft

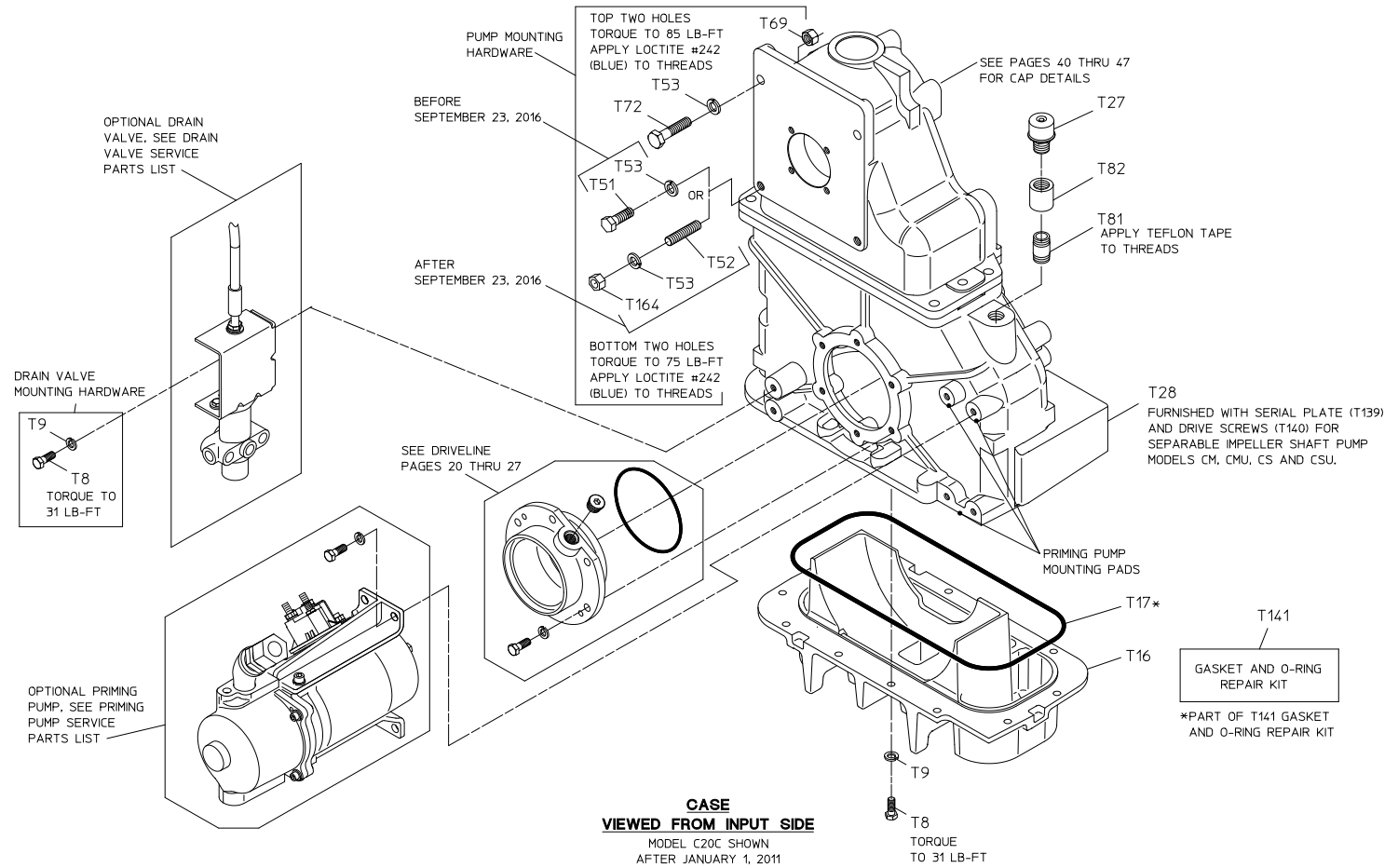

Case

Viewed from Input Side

REF. NO.	DESCRIPTION
T8	Hex Hd Screw, 3/8-16 x 1 in.
T9	Lock Washer, 3/8 in.
T16	Transmission Pan (Includes T84 and T85)
T17	Transmission Pan Gasket
T27	Breather
T28	Case
T51	Hex Hd Screw, 1/2-13 x 1-1/2 in.
T53	Lock Washer, 1/2 in.
T69	Hex Nut, 1/2-20

REF. NO.	DESCRIPTION
T72	Hex Hd Screw, 1/2-20 x 2-1/4 in.
T81	Pipe Nipple, 1/2 NPT x 1-1/2 in.
T82	Coupling, 1/2 NPT
T84	Tube Connector
T85	Cooling Tube, 3/8 in.
T134	Sight Plug, 3/4 NPT
T139	Serial Plate
T140	Drive Screw, No. 6 x 1/4 in.
T141	Gasket and O-ring Repair Kit

Hardware Torque Specifications

Screw Size	Torque Specification
5/16-18 UNC	17 lb-ft
3/8-16 UNC	31 lb-ft
1/2-13 UNC	75 lb-ft
1/2-20 UNF	85 lb-ft
5/8-11 UNC	150 lb-ft

Case

Viewed from Output Side

REF. NO.	DESCRIPTION
T8	Hex Hd Screw, 3/8-16 x 1 in.
T9	Lock Washer, 3/8 in.
T16	Transmission Pan
T17	Transmission Pan O-ring, 13 x 13-3/8
T28	Case
T57	Magnetic Drain Plug, 3/4-16 (Includes T78)
T61	Pipe Plug, 1/2 NPT
T77	Headless Pipe Plug, 1/8 NPT

REF. NO.	DESCRIPTION
T78	O-ring, 16.4 mm x 20.8 mm
T134	Sight Plug, 3/4 NPT
T139	Serial Plate
T140	Drive Screw, No. 6 x 1/4 in.
T141	Gasket and O-ring Repair Kit

Hardware Torque Specifications

Screw Size	Torque Specification
5/16-18 UNC	17 lb-ft
3/8-16 UNC	31 lb-ft
1/2-13 UNC	75 lb-ft
1/2-20 UNF	85 lb-ft
5/8-11 UNC	150 lb-ft

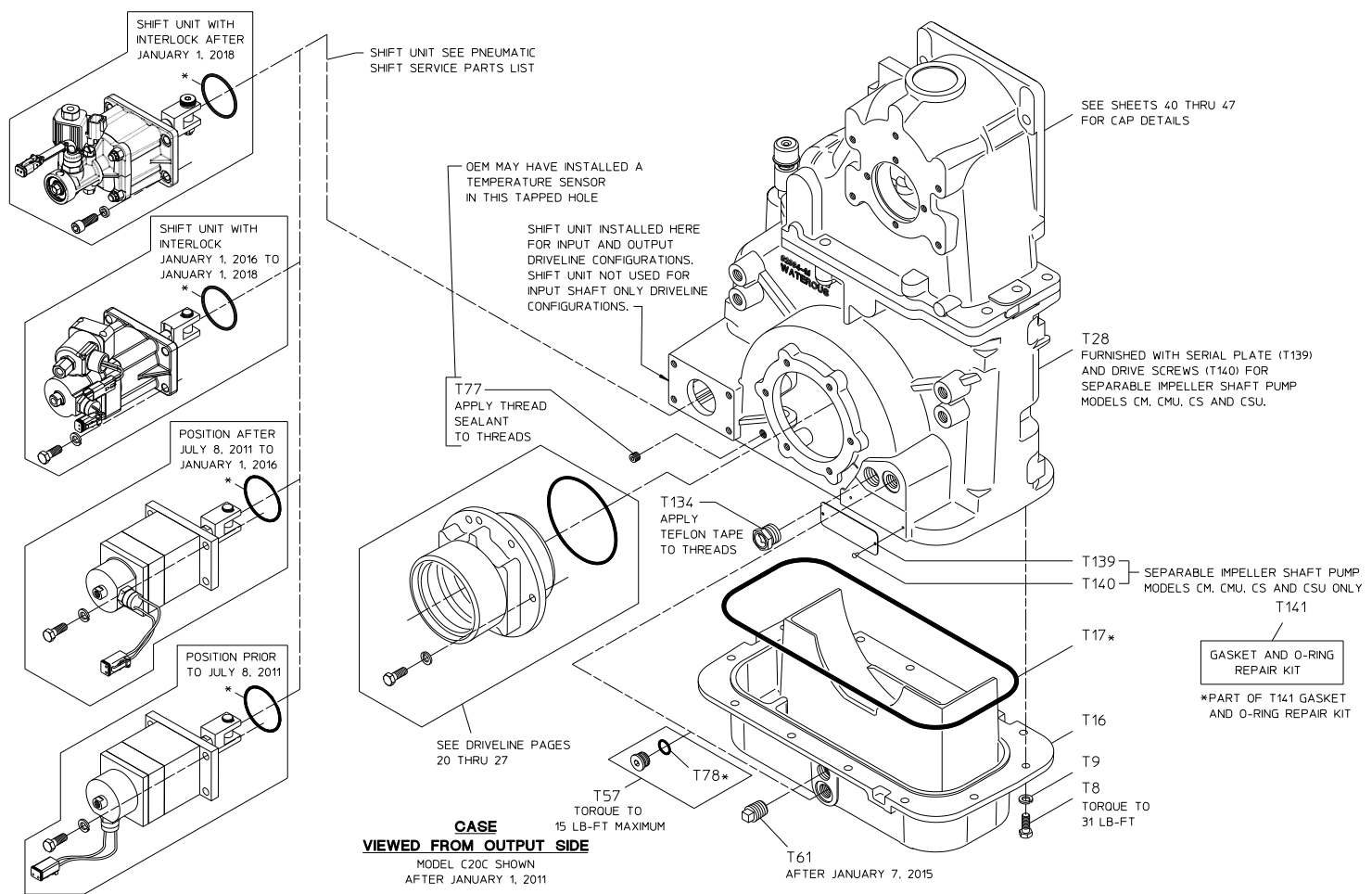

Case
Viewed from Output Side

REF. NO.	DESCRIPTION
T8	Hex Hd Screw, 3/8-16 x 1 in.
T9	Lock Washer, 3/8 in.
T16	Transmission Pan (Includes T84 and T85)
T17	Transmission Pan Gasket
T28	Case
T57	Magnetic Drain Plug, 3/4-16 (Includes T78)
T77	Headless Pipe Plug, 1/8 NPT

REF. NO.	DESCRIPTION
T78	O-ring, 16.4 mm x 20.8 mm
T85	Cooling Tube, 3/8 in.
T134	Sight Plug, 3/4 NPT
T139	Serial Plate
T140	Drive Screw, No. 6 x 1/4 in.
T141	Gasket and O-ring Repair Kit

Hardware Torque Specifications

Screw Size	Torque Specification
5/16-18 UNC	17 lb-ft
3/8-16 UNC	31 lb-ft
1/2-13 UNC	75 lb-ft
1/2-20 UNF	85 lb-ft
5/8-11 UNC	150 lb-ft

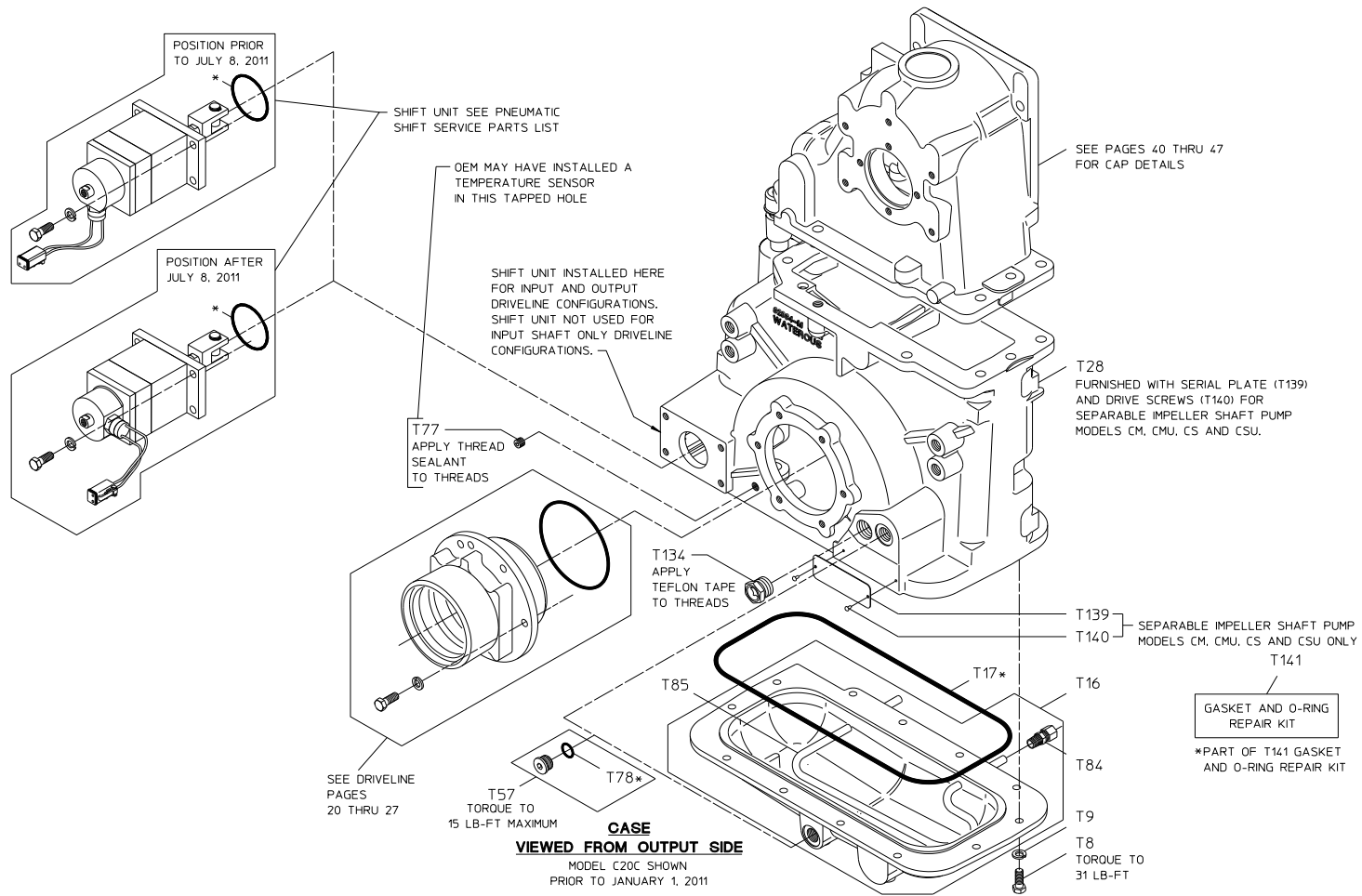

Case Cap Variations

Spacers, Shims and Sealant Application (Models C20B, C20C, C20D, C20E and C20F)

REF. NO.	DESCRIPTION
T28	Case
T63	Cap Seal Plug
T64	Oil Return Tube

REF. NO.	DESCRIPTION
T65	Case Cap
T99	Shim
T100	Case Spacer

Hardware Torque Specifications

Screw Size	Torque Specification
5/16-18 UNC	17 lb-ft
3/8-16 UNC	31 lb-ft
1/2-13 UNC	75 lb-ft
1/2-20 UNF	85 lb-ft
5/8-11 UNC	150 lb-ft

APPLY LOCTITE®518 SEALANT OR EQUIVALENT TO MATING FLANGES AND BETWEEN SHIMS

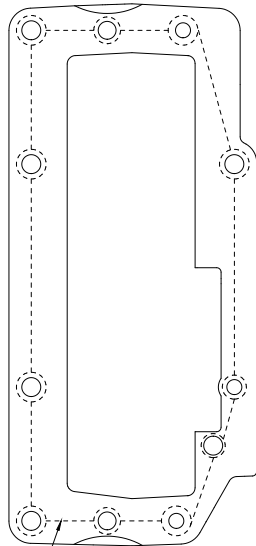

APPLY A THIN BEAD OF SEALANT AS SHOWN BY DASHED LINE (CASE FLANGE SHOWN)

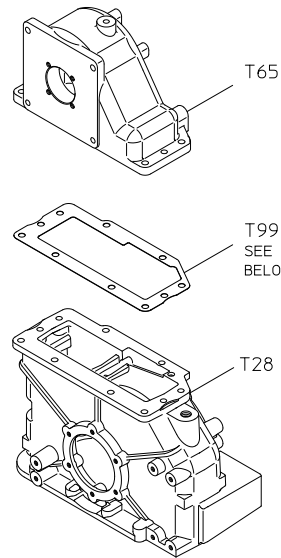

MODEL C20B

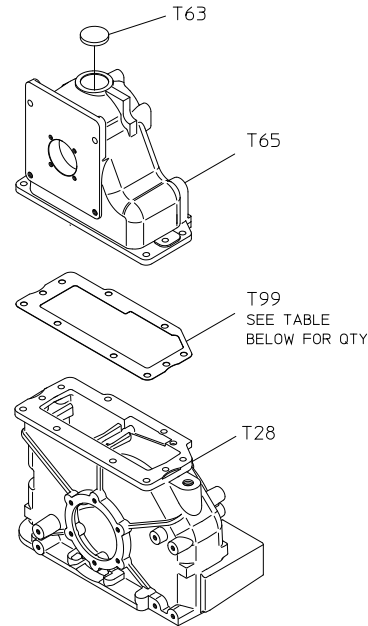

MODEL C20C & C20D

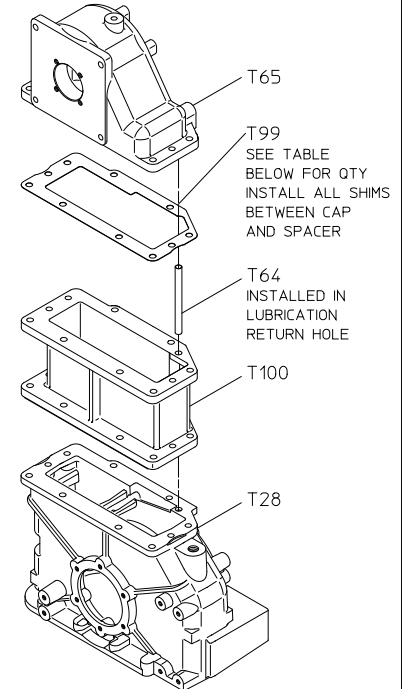

MODEL C20E & C20F

RATIO	QTY OF T99 SHIMS														
	MODEL C20B			MODEL C20C			MODEL C20D			MODEL C20E			MODEL C20F		
	.010 BROWN	.025 WHITE	.031 ORANGE	.010 BROWN	.025 WHITE	.031 ORANGE	.010 BROWN	.025 WHITE	.031 ORANGE	.010 BROWN	.025 WHITE	.031 ORANGE	.010 BROWN	.025 WHITE	.031 ORANGE
1.27	2	1	0	3	7	2	1	0	2	2	0	1	0	0	1
1.41	0	0	0	1	2	0	0	0	2	0	1	0	0	0	1
1.48	4	2	1	3	2	2	2	0	1	0	0	1	1	0	0
1.58	0	0	0	2	0	0	1	1	0	2	0	0	0	0	0
1.69	1	3	0	0	0	0	2	0	0	2	0	3	0	4	0
1.79	0	0	2	0	0	0	1	0	0	3	2	1	2	2	1
1.88	2	0	0	1	0	0	2	0	0	1	1	1	2	0	1
1.97	2	2	1	0	0	1	0	1	1	0	2	0	1	0	1
2.03	0	0	0	1	1	0	0	0	2	2	2	0	4	1	0
2.27	1	1	0	0	3	0	0	0	0	0	0	0	0	0	0
2.46	2	1	0	0	1	2	0	1	0	2	1	3	2	1	3
2.68	1	2	0	1	0	0	4	0	0	3	1	0	0	0	2

CASE ASSEMBLY, SPACERS AND SHIMS

Case Cap Variations

Hardware for Model C20B

REF. NO.	DESCRIPTION
T51	Hex Hd Screw, 1/2-13 x 1-1/2 in.
T53	Lock Washer, 1/2 in.
T69	Hex Nut, 1/2-20

REF. NO.	DESCRIPTION
T72	Hex Hd Screw, 1/2-20 x 2-1/4 in.
T103	Dowel Pin, 1/2 x 1-1/2 in.

Hardware Torque Specifications

Screw Size	Torque Specification
5/16-18 UNC	17 lb-ft
3/8-16 UNC	31 lb-ft
1/2-13 UNC	75 lb-ft
1/2-20 UNF	85 lb-ft
5/8-11 UNC	150 lb-ft

Case Cap Variations

Hardware for Models C20C and C20D

REF. NO.	DESCRIPTION
T51	Hex Hd Screw, 1/2-13 x 1-1/2 in.
T53	Lock Washer, 1/2 in.
T69	Hex Nut, 1/2-20
T71	Hex Hd Screw, 1/2-20 x 2 in.

REF. NO.	DESCRIPTION
T72	Hex Hd Screw, 1/2-20 x 2-1/4 in.
T103	Dowel Pin, 1/2 x 1-1/2 in.

Hardware Torque Specifications

Screw Size	Torque Specification
5/16-18 UNC	17 lb-ft
3/8-16 UNC	31 lb-ft
1/2-13 UNC	75 lb-ft
1/2-20 UNF	85 lb-ft
5/8-11 UNC	150 lb-ft

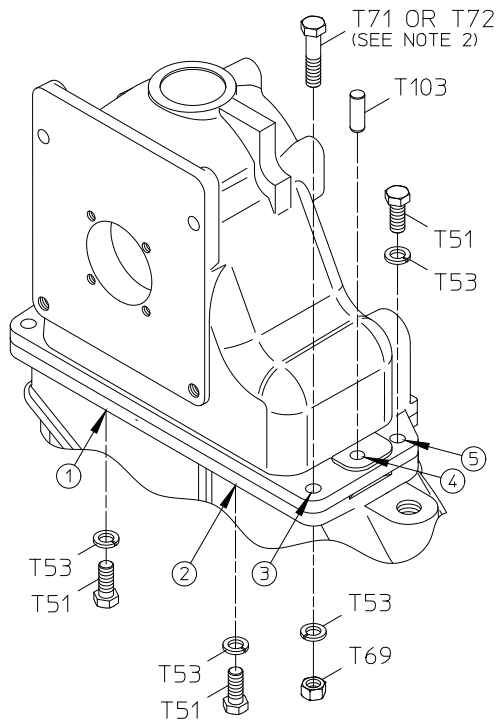

VIEWED FROM INPUT SIDE OF CASE

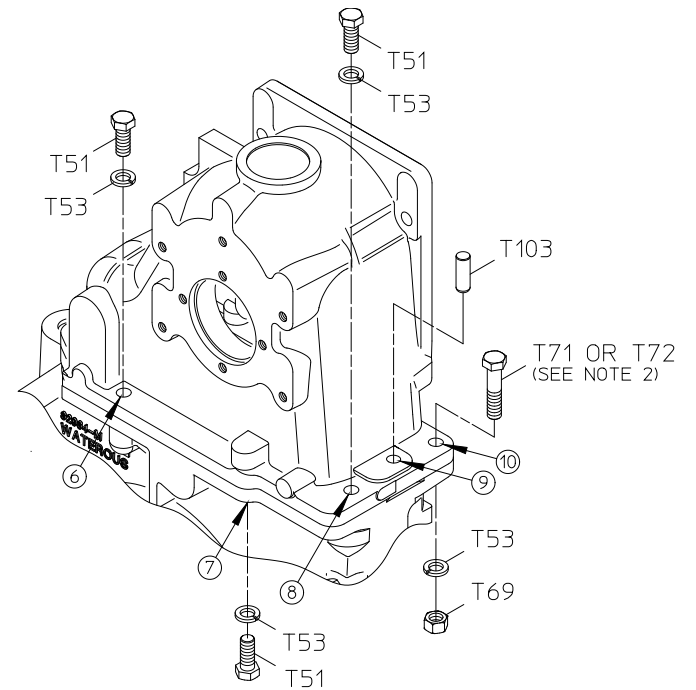

VIEWED FROM OUTPUT SIDE OF CASE

FLANGE HARDWARE BETWEEN CAP (T65) AND CASE (T28)

REF NO.	HARDWARE DESCRIPTION	HOLE NUMBER										QTY	TORQUE SPECIFICATION	
		1	2	3	4	5	6	7	8	9	10			
T51	SCREW-HEX HD, 1/2-13 X 1.50	1	1			1	1	1	1				6	75 LB-FT
T53	WASHER-LOCK, 1/2	1	1	1		1	1	1	1			1	8	-
T69	NUT-HEX, 1/2-20			1								1	2	-
T71	SCREW-HEX HD, 1/2-20 X 2.00			1								1	2	85 LB-FT
T72	SCREW-HEX HD, 1/2-20 X 2.25 (SEE NOTE 2)			1								1	2	85 LB-FT
T103	PIN-DOWEL, 1/2 X 1-1/2				1					1		2	2	-

NOTES:

- HOLES 1, 2 AND 7 ARE BLIND HOLES THAT ARE TAPPED INTO THE CAP AND ARE NOT SHOWN.
- T72 USED ON 1.27 RATIO ONLY, T71 IS USED ON ALL OTHER RATIOS.

CASE CAP VARIATIONS
HARDWARE FOR MODELS C20C & C20D

Case Cap Variations

Hardware for Models C20E and C20F

REF. NO.	DESCRIPTION
T51	Hex Hd Screw, 1/2-13 x 1-1/2 in.
T53	Lock Washer, 1/2 in.
T69	Hex Nut, 1/2-20

REF. NO.	DESCRIPTION
T71	Hex Hd Screw, 1/2-20 x 2 in.
T103	Dowel Pin, 1/2 x 1-1/2 in.

Hardware Torque Specifications

Screw Size	Torque Specification
5/16-18 UNC	17 lb-ft
3/8-16 UNC	31 lb-ft
1/2-13 UNC	75 lb-ft
1/2-20 UNF	85 lb-ft
5/8-11 UNC	150 lb-ft

Case Oil Cooler Option

After April 8, 2020

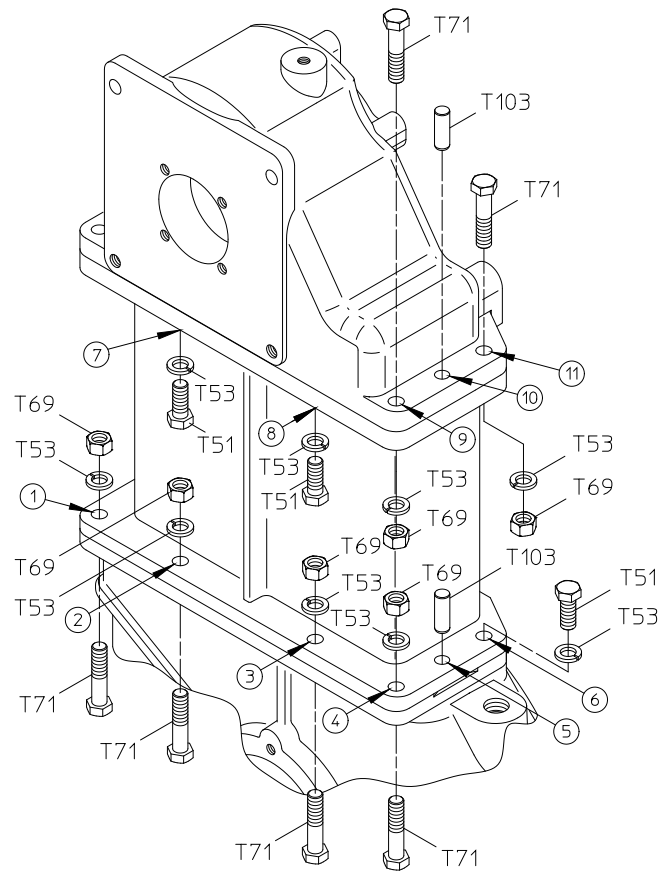

VIEWED FROM INPUT SIDE OF CASE

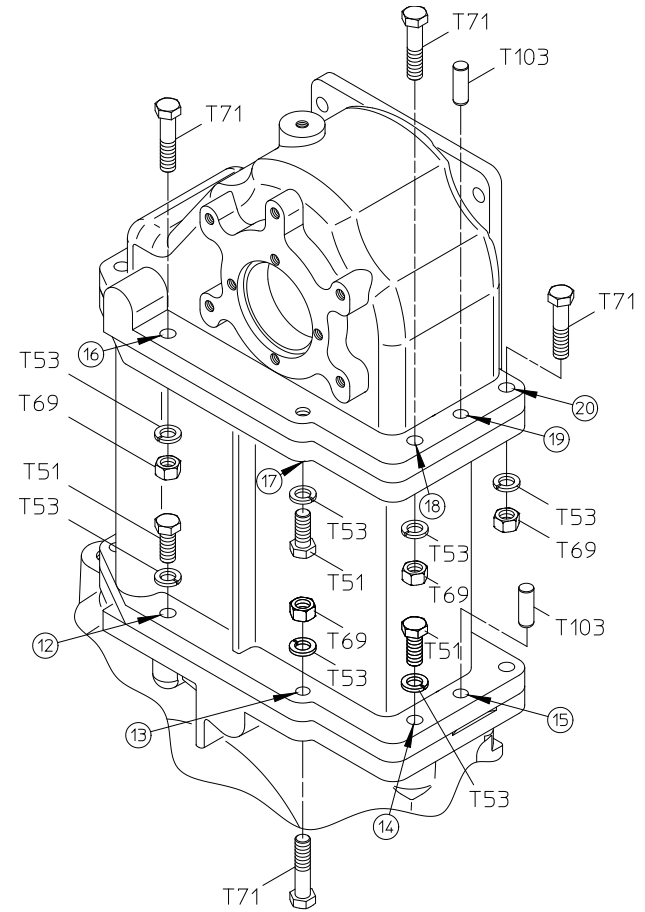

VIEWED FROM OUTPUT SIDE OF CASE

FLANGE HARDWARE BETWEEN CAP (T65), SPACER (T100) AND CASE (T28)

REF NO.	HARDWARE DESCRIPTION	HOLE NUMBER																				QTY	TORQUE SPECIFICATION
		1	2	3	4	5	6	7	8	9	10	11	12	13	14	15	16	17	18	19	20		
T51	SCREW-HEX HD, 1/2-13 X 1.50						1	1	1				1		1			1				6	75 LB-FT
T53	WASHER-LOCK, 1/2	1	1	1	1		1	1	1	1		1	1	1		1	1	1		1		16	-
T69	NUT-HEX, 1/2-20	1	1	1	1					1		1				1		1		1		10	-
T71	SCREW-HEX HD, 1/2-20 X 2.00	1	1	1	1					1		1				1		1		1		10	85 LB-FT
T103	PIN-DOWEL, 1/2 X 1-1/2					1						1				1				1		4	-

NOTE:

1. HOLES 7 & 8 ARE BLIND HOLES THAT ARE TAPPED INTO THE CAP AND ARE NOT SHOWN.

CASE CAP VARIATIONS
HARDWARE FOR MODELS C20E & C20F

Case Oil Cooler Option

After April 8, 2020

REF. NO.	DESCRIPTION
T58	Street Elbow, 90 Degrees, 1/2 NPT
T60	Pipe Tee, 1/2 NPT
T61	Pipe Plug, 1/2 NPT
T67	Oil Return Hose
T135	Oil Filter
T168	Pipe Nipple, 1/2 NPT x 1-1/2 in.

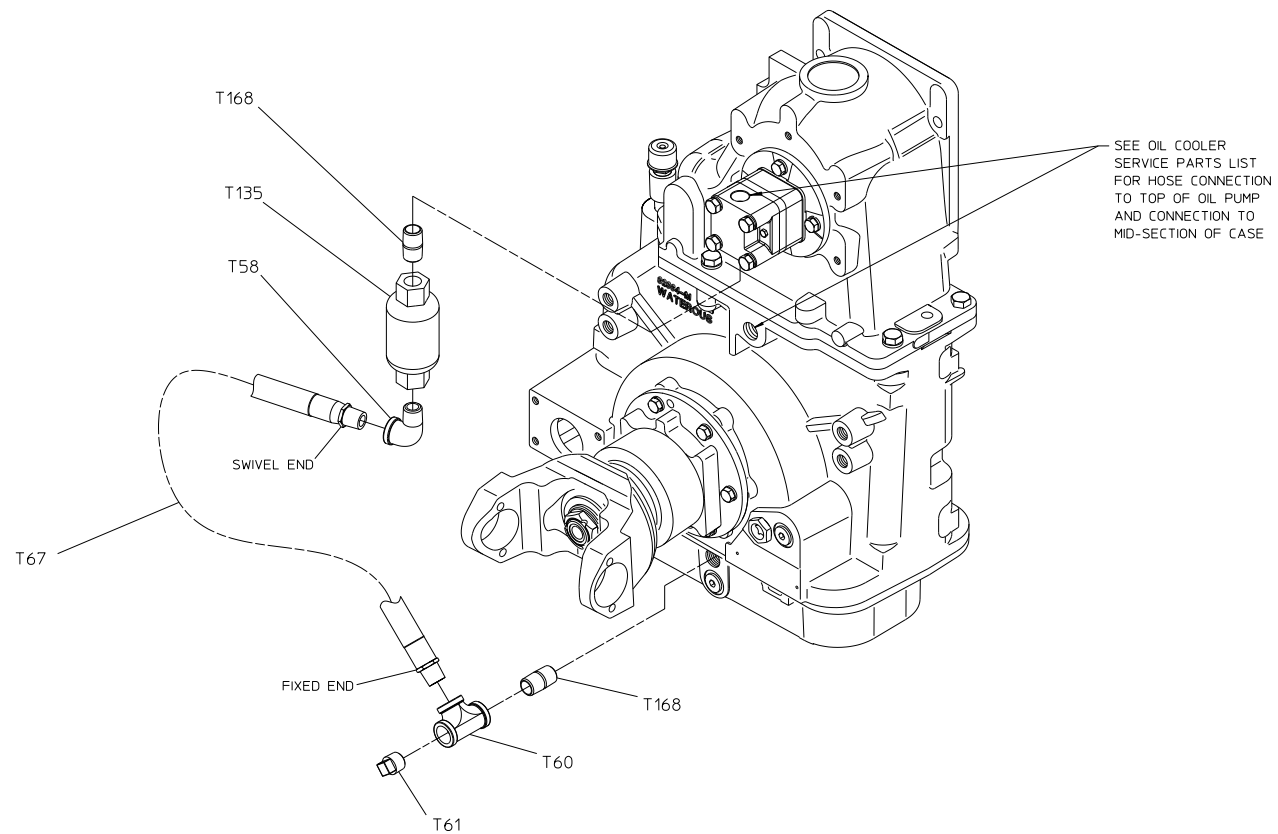

- NOTES:
1. APPLY TEFLON TAPE TO ALL THREADS.
 2. SEE PAGES 50 THRU 55 FOR PRIOR CONFIGURATIONS.

OIL COOLER HOSE AND PLUMBING
 CONFIGURATION AFTER APRIL 8, 2020

Case Oil Cooler Option
After Feb. 13, 2014 to April 8, 2020

REF. NO.	DESCRIPTION
T58	Street Elbow, 90 Degrees, ½ NPT
T67	Oil Return Hose
T143	Clamp Bracket
T144	Strainer (Includes T145)
T145	Screen
T147	Reducing Bushing, ¾ NPT x ½ NPT
T149	Pipe Nipple, ½ NPT x 10 in.
T150	Clamp Body (Consists of Two Pieces)
T151	Cover Plate
T152	Hex Hd Screw, ¼-20 x 2-¼ in.

REF. NO.	DESCRIPTION
T153	Plain Washer, ¼ in.
T154	Lock Washer, ¼ in.
T155	Hex Nut, ¼-20
T157	Hex Hd Screw, 5/8-11 x 1-¼ in.
T158	Lock Washer, 5/8 in.
T159	Plain Washer, 5/8 in.
T160	Standard Elbow, 90 Degrees, ½ NPT
T161	Pipe Nipple, ½ NPT x 3 in.
T162	Pipe Nipple, ¾ NPT x 1-3/8 in.
T163	Adapter, 90 Degrees, ¾-16 x ¾ NPT

Hardware Torque Specifications

Screw Size	Torque Specification
5/16-18 UNC	17 lb-ft
3/8-16 UNC	31 lb-ft
1/2-13 UNC	75 lb-ft
1/2-20 UNF	85 lb-ft
5/8-11 UNC	150 lb-ft

Case Oil Cooler Option
August 13, 2013 to February 13, 2014

REF. NO.	DESCRIPTION
T67	Oil Return Hose
T143	Clamp Bracket
T144	Strainer (Includes T145)
T145	Screen
T146	Elbow Adapter, 3/4-16 x 1/2 NPT
T147	Reducing Bushing, 3/4 NPT x 1/2 NPT
T148	Street Elbow, 90 Degrees, 3/4 NPT
T149	Pipe Nipple, 1/2 NPT x 8 in.
T150	Clamp Body (Consists of Two Pieces)

REF. NO.	DESCRIPTION
T151	Cover Plate
T152	Hex Hd Screw, 1/4-20 x 2-1/4 in.
T153	Plain Washer, 1/4 in.
T154	Lock Washer, 1/4 in.
T155	Hex Nut, 1/4-20
T156	Straight Adapter, 1/2 NPT x 1/2 NPT
T157	Hex Hd Screw, 5/8-11 x 1-1/4 in.
T158	Lock Washer, 5/8 in.
T159	Plain Washer, 5/8 in.

Hardware Torque Specifications

Screw Size	Torque Specification
5/16-18 UNC	17 lb-ft
3/8-16 UNC	31 lb-ft
1/2-13 UNC	75 lb-ft
1/2-20 UNF	85 lb-ft
5/8-11 UNC	150 lb-ft

SEE OIL COOLER
SERVICE PARTS LIST
FOR HOSE CONNECTION
TO OPPOSITE SIDE
OF OIL PUMP AND
CONNECTION TO
MID-SECTION OF CASE

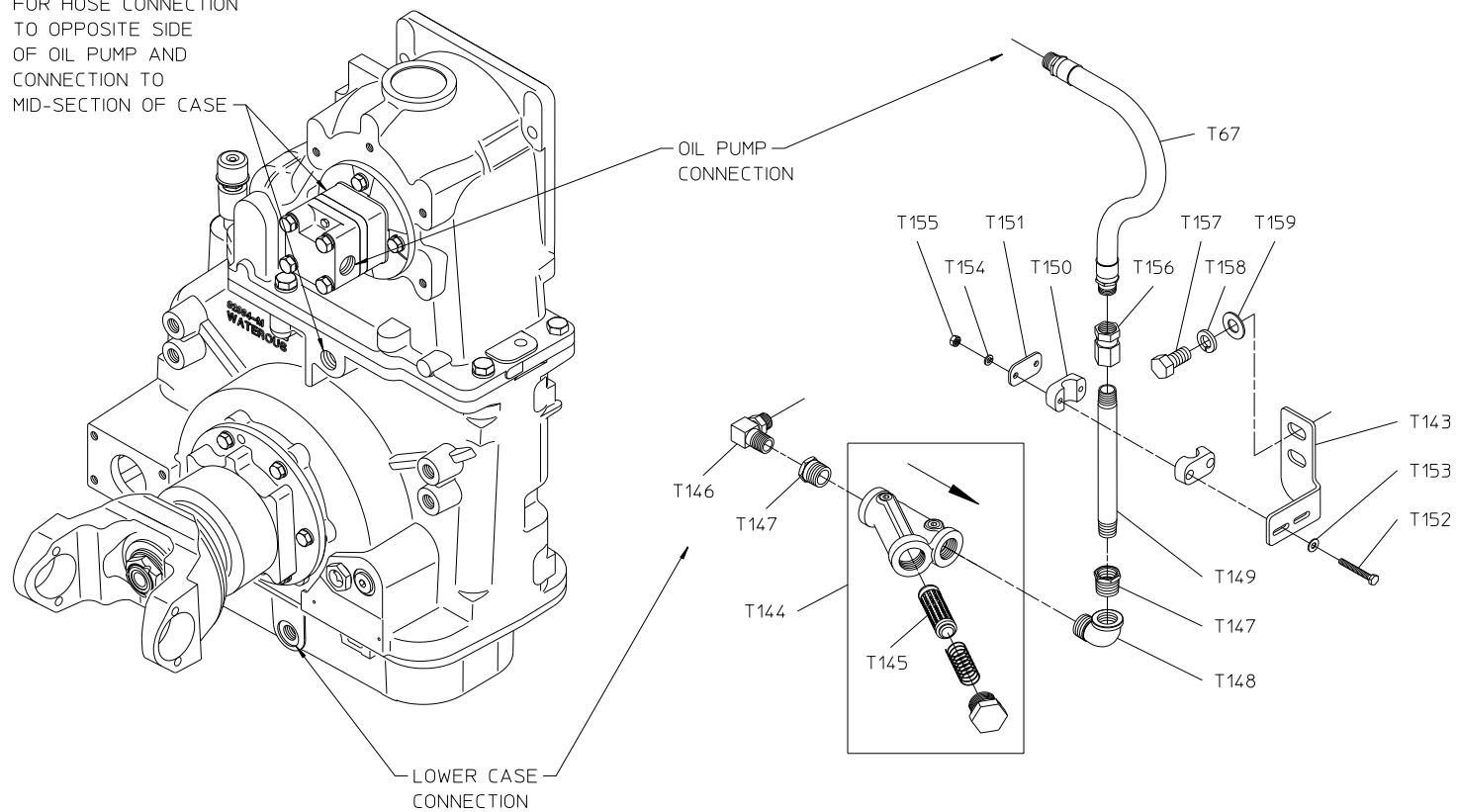

NOTE:
1. APPLY TEFLON TAPE TO ALL THREADS

OIL COOLER OPTION

CONFIGURATION AUGUST 30, 2013 TO FEBRUARY 13, 2014

Case Oil Cooler Option
January 1, 2009 to August 30, 2013

REF. NO.	DESCRIPTION
T58	Street Elbow, 90 Degree, 1/2 NPT
T59	Pipe Nipple, 1/2 NPT x 2-1/2 in.
T60	Pipe Tee, 1/2 NPT
T61	Pipe Plug, 1/2 NPT
T66	Straight Hose Adapter, 1/2 NPSM (F) x 1/2 NPT (M)
T67	Oil Return Hose

REF. NO.	DESCRIPTION
T78	O-ring, 16.4 mm x 20.8 mm
T132	Oil Strainer
T135	Oil Strainer
T136	Straight Adapter (Includes T78)
T137	Pipe Nipple, 1/2 NPT x 1-1/8 in.
T138	Magnetic Pipe Plug, 1/2 NPT

Hardware Torque Specifications

Screw Size	Torque Specification
5/16-18 UNC	17 lb-ft
3/8-16 UNC	31 lb-ft
1/2-13 UNC	75 lb-ft
1/2-20 UNF	85 lb-ft
5/8-11 UNC	150 lb-ft

SEE OIL COOLER
SERVICE PARTS LIST
FOR HOSE CONNECTION
TO OPPOSITE SIDE
OF OIL PUMP AND
CONNECTION TO
MID-SECTION OF CASE

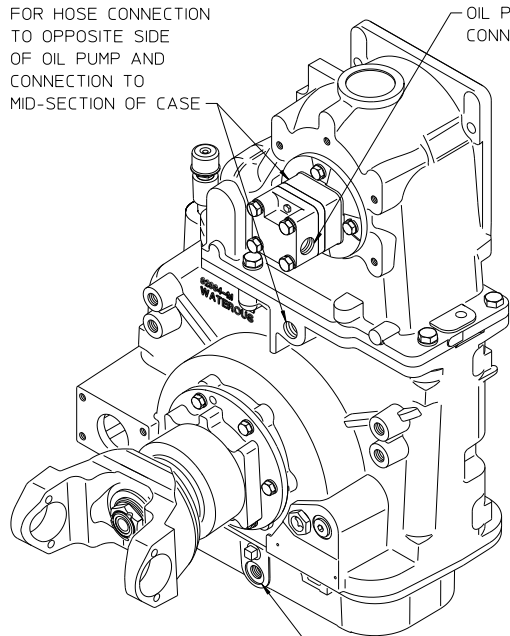

LOWER CASE
CONNECTION

OIL PUMP
CONNECTION

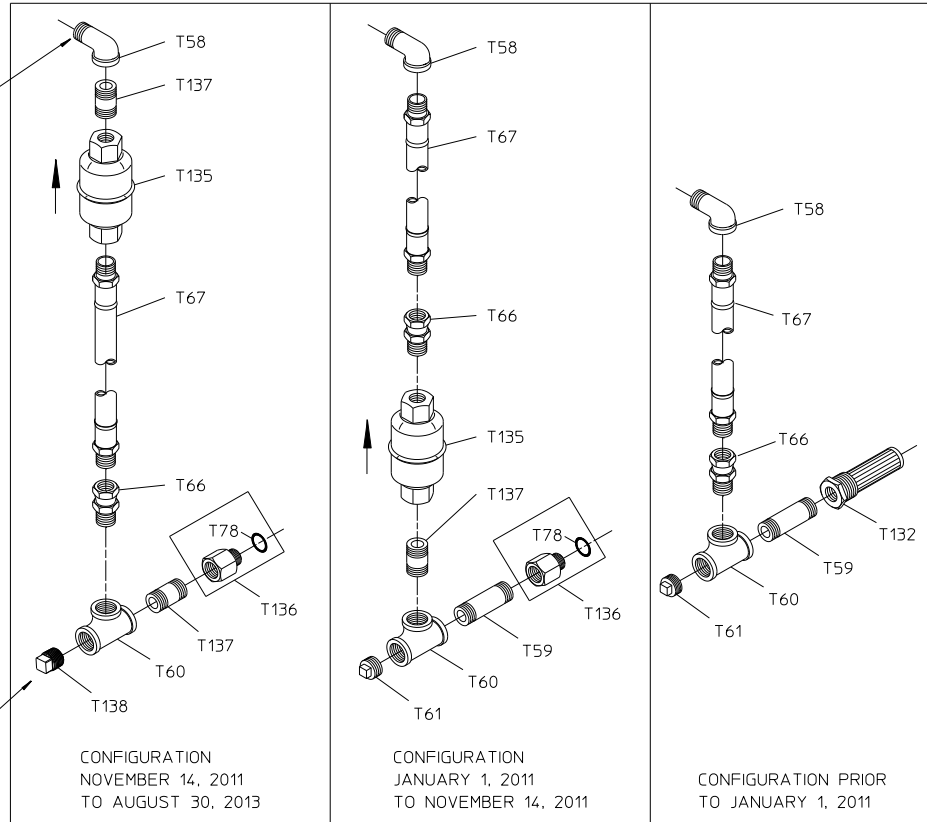

NOTE:
1. APPLY TEFLON TAPE TO ALL THREADS

OIL COOLER OPTION