

# S200-P Passport™ Series Pump Service Parts List

Component		See Pages
Pump Body and Impeller		2
Pedestal and Primers		3
Cross Section Views	Through Impeller Shaft	4
	Through Primers	5

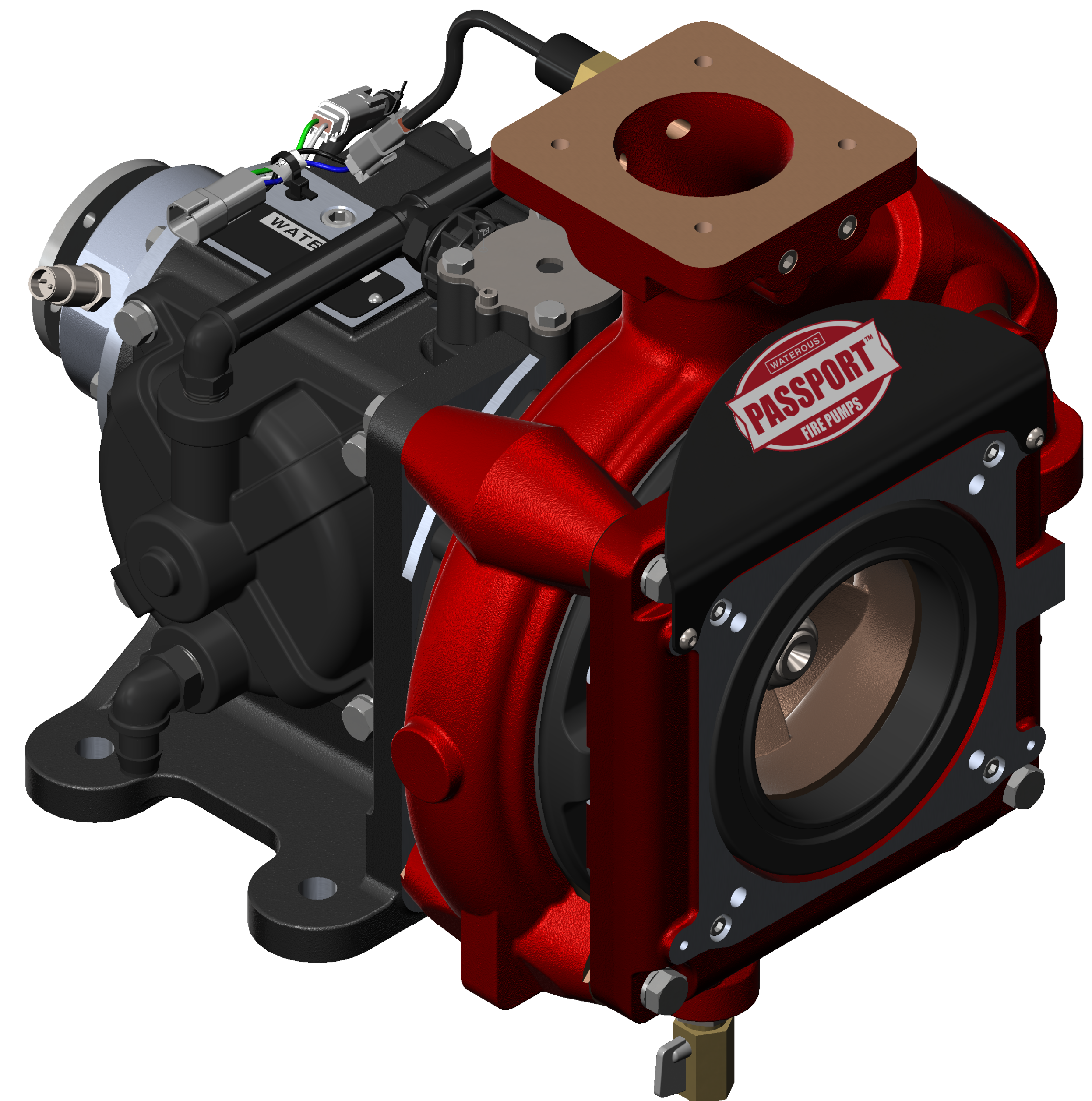

Ref No.	Description
1	Body-Volute
2	Impeller-CCW
3	Head-Pump
4	Head-Intake
5	Adapter-Intake
6	Housing-Seal, Mechanical
7	Bracket-Label, Passport
8	Screw-Soc Hd, M6-1 x 55 mm
9	Washer-Lock, 6 mm
10	Screw-Hex Hd, M12-1.75 x 50 mm
11	Washer-Lock, 12 mm
12	Plate-Serial
13	Screw-Drive, #6 x 1/4 in
15	O-Ring, 10-1/2 x 10-7/8 in
16	Plug-Pipe, JIS, 1/4 BSPT
17	Pin-Dowel, 1/4 x 1-1/4 in
18	Screw-Soc Button Hd, M6-1 x 12 mm
21	Valve-Ball, 1/2 NPT
22	Bushing-Reducing, Pipe, 3/4 x 1/2 NPT
23	Plug-Pipe, JIS, 1/4 BSPT
24	Switch-Pressure, Low, 1/4 BSPT
30	O-Ring, 2-1/2 x 2-3/4 in
31	Seal-Mechanical, Ø1.750 Shaft
32	Screw-Soc Hd, M6-1 x 16 mm
33	Washer-Lock, 6 mm
34	O-Ring, 3 x 3-1/4 in
35	Valve-Thermal Relief
36	Wire-Assembly
37	Vacuum Activated Priming Valve (VAP)
38	Screw-Hex Hd, M8-1.25 x 45 mm
39	Key, 8 x 10 x 32 mm
40	Screw-Hex Hd, M6-1 x 35 mm
42	Vacuum Activated Priming Valve Repair Kit
43	O-Ring Replacement Kit
92	Tie-Cable
94	Gasket-Mechanical Seal Housing
98	O-Ring, 1-9/16 x 1-3/4 in
99	Washer Nord-Lock, 24 mm
100	Nut-Lock, M24- 3

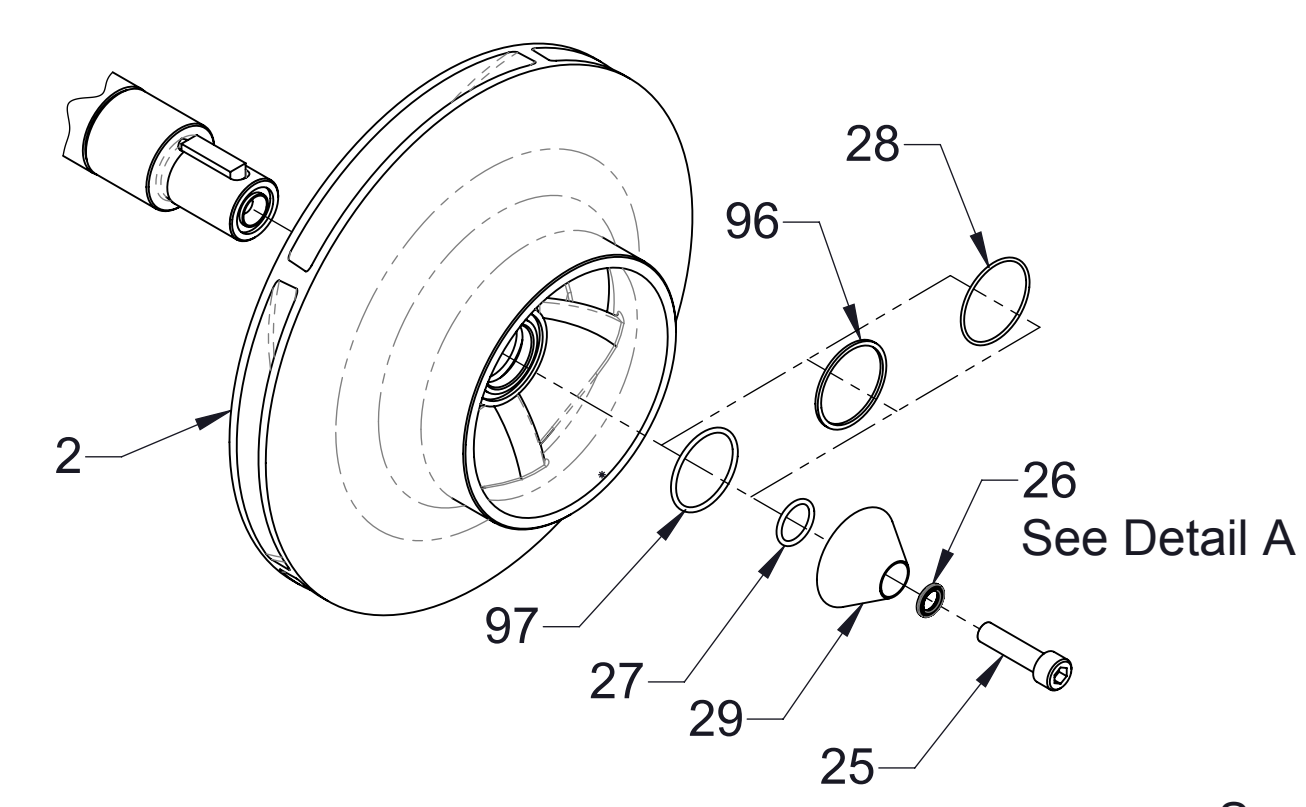

Ref No.	Description
2	Impeller-CCW
25	Screw-Soc Hd, M10-1.5 x 40 mm
26	Washer Nord-Lock, 10 mm
27	O-Ring, 3/4 x 15/16 in
28	O-Ring, 1-5/8 x 1-3/4 in
29	Washer-Impeller
96	Gasket-Impeller
97	O-Ring, 1-1/2 x 1-11/16 in

**Impeller Cone Design**  
(Used prior to February 1, 2020)

- Service Notes:
- 28 used prior to August 1, 2018
  - 96 used between August 1, 2018 and September 20, 2018
  - 97 used between September 20, 2018 and February 1, 2020
  - 25, 26, 27, & 29 used prior to February 1, 2020
  - 25: Apply Loctite 242 (blue) to threads.

- Notes:
- Apply Loctite 242 (Blue) to all straight thread fasteners unless noted otherwise.
  - Apply Loctite 567 (White) to all metal tapered threads unless noted otherwise.
  - Tighten 1/2 to 1 turn past hand tight or until sealed. Max torque: 15 ft-lb / 20 N.m.
  - Mechanical seal kit includes 15, 26, 27, 30, 31, 34, 94, 96, 97, 98, 99, & 100
  - O-ring replacement kit includes 15 (2), 27, 30, 34, 80 (2) (See page 3), 94, 96, 97, & 98
  - 98, 99, & 100 Used after February 1, 2020.
  - 98 O-ring was black prior to May 1, 2020.

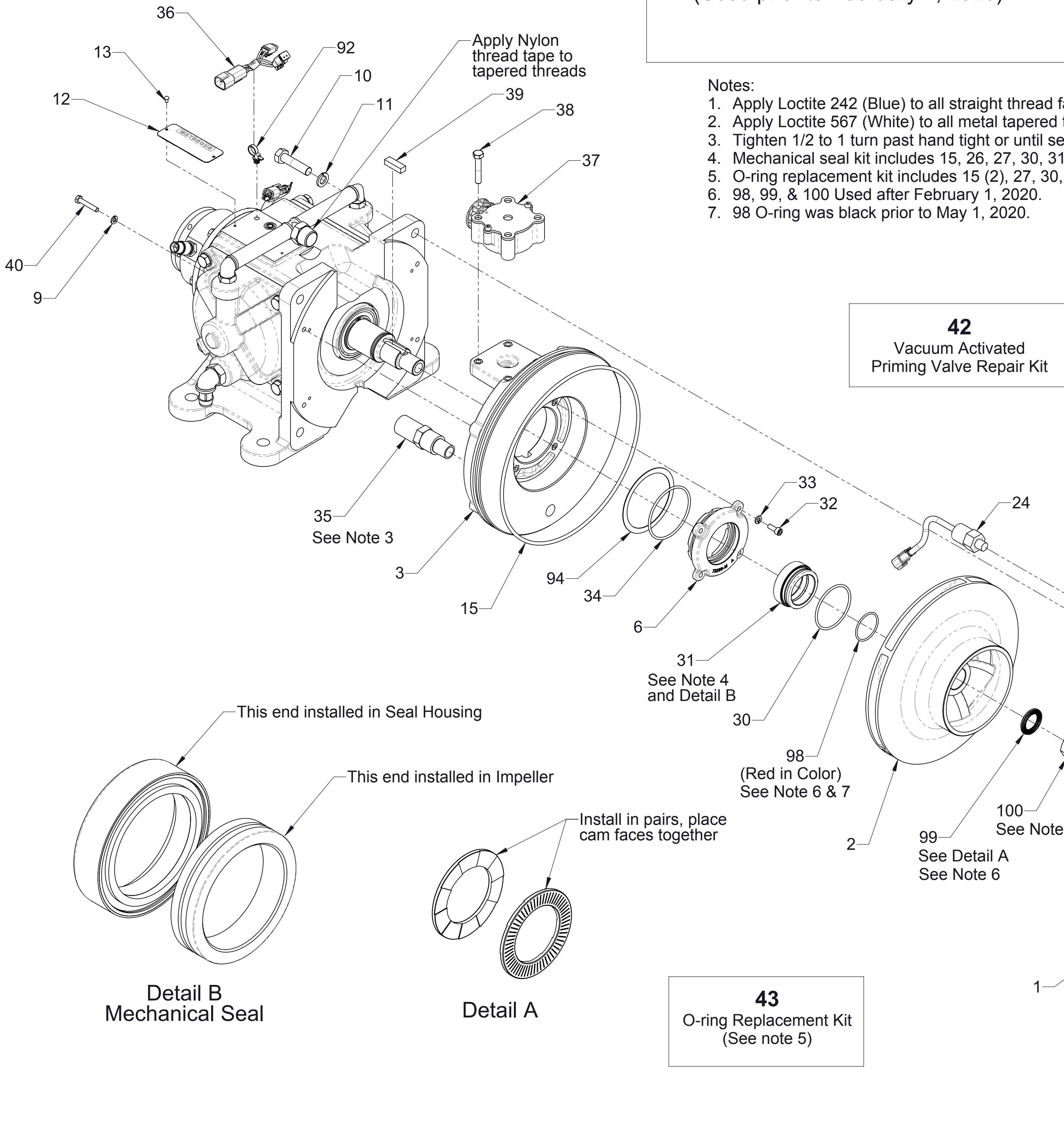

Fastener Details	
Ref No.	Torque Spec
8	7 ft-lb / 10 N.m
25	50 ft-lb / 68 N.m
32	7 ft-lb / 10 N.m
38	13 ft-lb / 18 N.m
40	7 ft-lb / 10 N.m

**43**  
O-ring Replacement Kit  
(See note 5)

**Detail B**  
Mechanical Seal

**Detail A**

# Pump Body and Impeller

(CW Input rotation shown)

Ref No.	Description	Ref No.	Description	Ref No.	Description
9	Washer-Lock, 6 mm	61	Spacer-Hub, Rotor	79	Wear-Strip
39	Key, 8 x 10 x 32 mm	62	Housing-Bearing	80	O-Ring, 5-3/4 x 6 in
44	Primer Repair Kit	63	Screw-Hex Hd, M8-1.25 x 25 mm	81	Screw-Soc Countersunk Hd, M6-1 x 60 mm
46	Body-Pedestal	64	Washer-Lock, 8 mm	82	Washer
47	Screw-Set, Cup Point, Hex Soc, 5/8-18 x 5/8 in	65	Pickup-Magnetic, Tachometer	83	Diaphragm-Inlet
48	Ring-Retaining, External, 1.772 in Shaft Dia	66	Ring-Retaining, External, 2-5/32 in Shaft Dia	84	Retainer-Diaphragm
49	Bearing, Ball, Double Row, Double Sealed, 45 x 85 x 30.2 mm	67	Bearing, Ball, Single Row, Double Sealed, 55 x 100 x 21 mm	85	Diaphragm-Outlet
50	Ring-Retaining, Internal, 3.346 in Bore Dia	68	Flange-Companion, DIN-100	86	Cover-Piston
51	Shaft-Impeller	69	Screw-Hex Hd, M8-1.25 x 35 mm	87	Elbow-Fitting, Barbed, 3/4 NPT x 3/4 in ID Tube
52	Key, 8 x 10 x 20 mm	70	Screw-Hex Hd, M6-1 x 12 mm	88	Screw-Hex Hd, M10-1.5 x 30 mm
53	Spring-Wave	71	Cover-Pedestal	89	Washer-Flat, 10 mm
54	Bearing, Ball, Single Row, Double Shield, 40 x 80 x 18 mm	72	Tee Fitting-Barbed Tube, 3/4 NPT x 5/8 in ID Tube	90	Elbow-Fitting, Barbed, 1/2 NPT x 5/8 in ID Tube
55	Shaft-Eccentric	73	Cylinder-Primer	91	Tube-Priming
56	Cover-Eccentric Shaft	74	Rod-Tie	92	Tie-Cable
57	Spacer-Gap, Air	75	Piston Assembly	112	O-Ring, 1-9/16 x 1-3/4 in
58	Screw-Soc Hd, M5-.8 x 16 mm	76	Seal-Piston		
59	Clutch-Magnetic	77	Head-Piston		
60	Screw-Soc Hd Cap, Low Hd, M5-.8 x 12 mm	78	Screw-Soc Countersunk Hd, M8-1.25 x 30 mm		

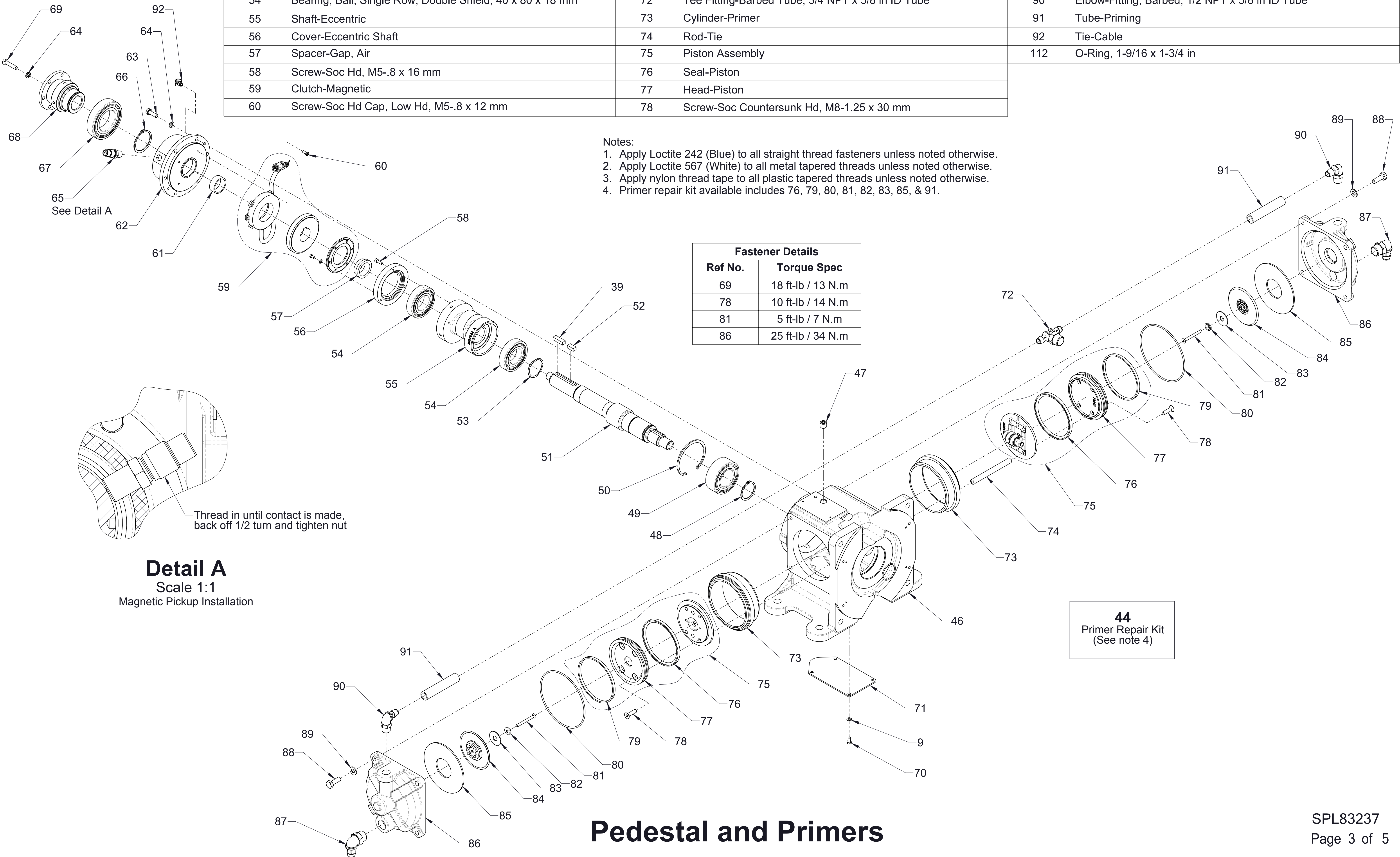

- Notes:
1. Apply Loctite 242 (Blue) to all straight thread fasteners unless noted otherwise.
  2. Apply Loctite 567 (White) to all metal tapered threads unless noted otherwise.
  3. Apply nylon thread tape to all plastic tapered threads unless noted otherwise.
  4. Primer repair kit available includes 76, 79, 80, 81, 82, 83, 85, & 91.

Fastener Details	
Ref No.	Torque Spec
69	18 ft-lb / 13 N.m
78	10 ft-lb / 14 N.m
81	5 ft-lb / 7 N.m
86	25 ft-lb / 34 N.m

**Detail A**  
Scale 1:1  
Magnetic Pickup Installation

**44**  
Primer Repair Kit  
(See note 4)

# Pedestal and Primers

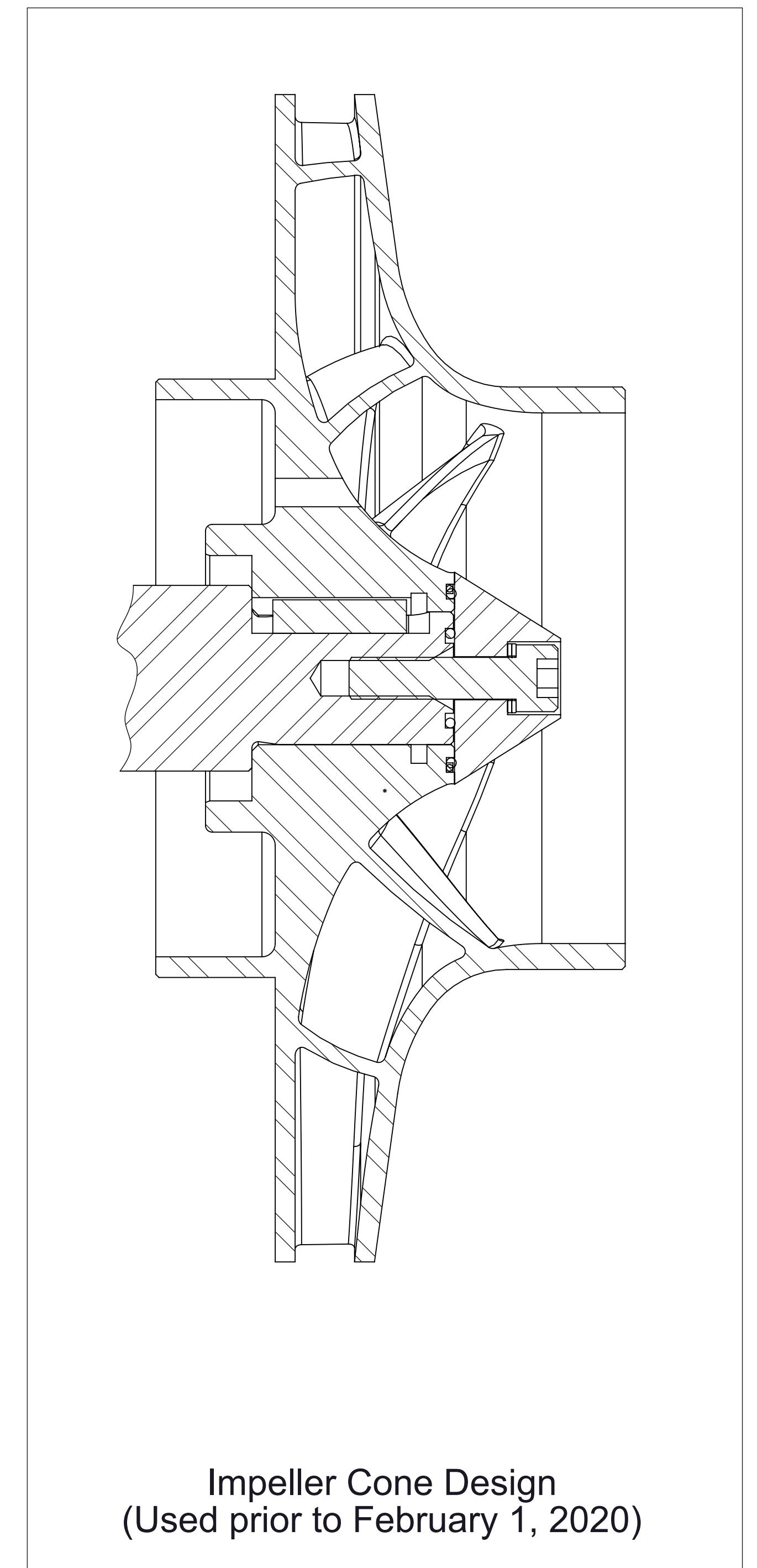
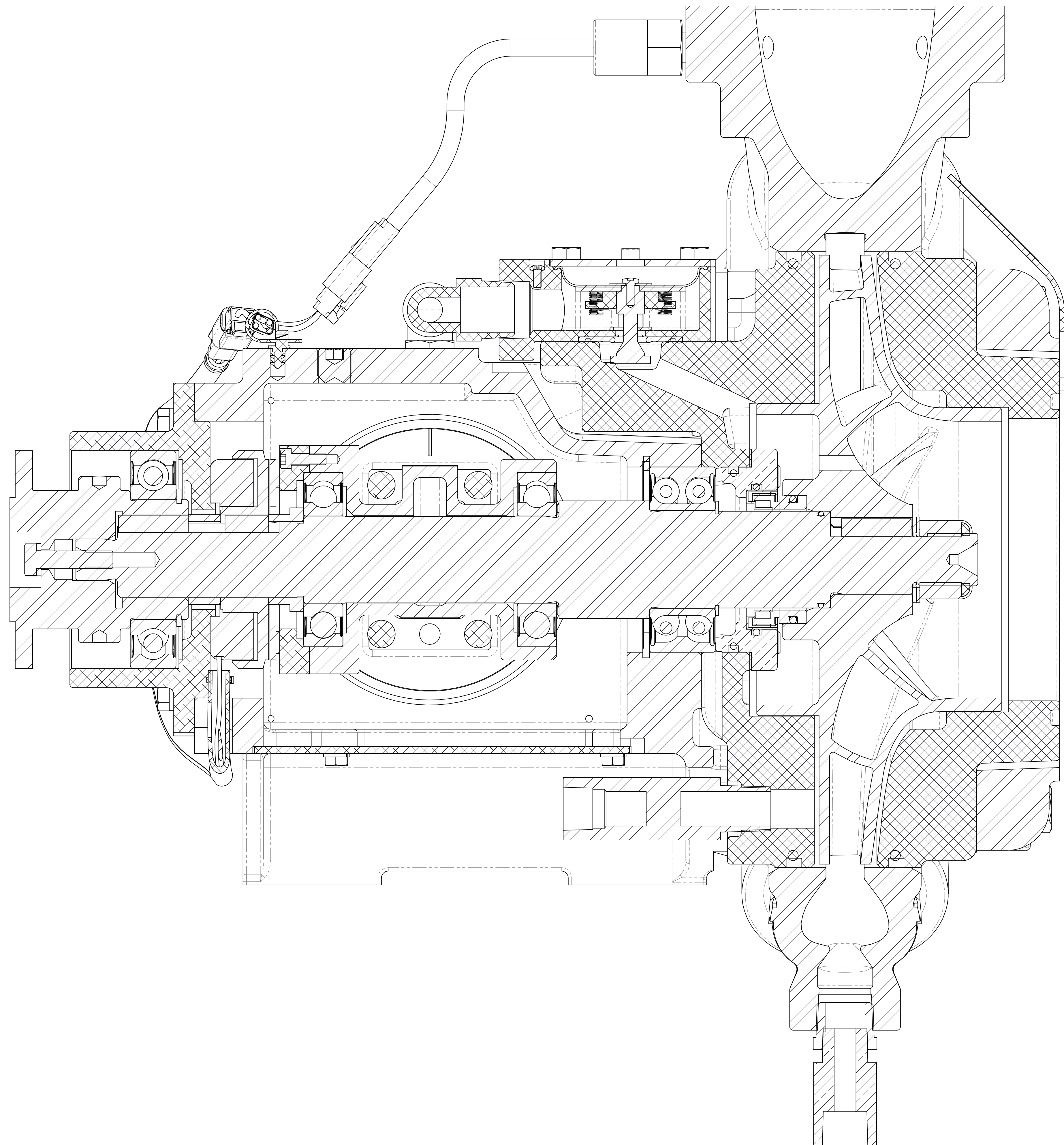

**Cross Section View - Through Impeller Shaft**  
(See pages 2-3 for reference numbers)

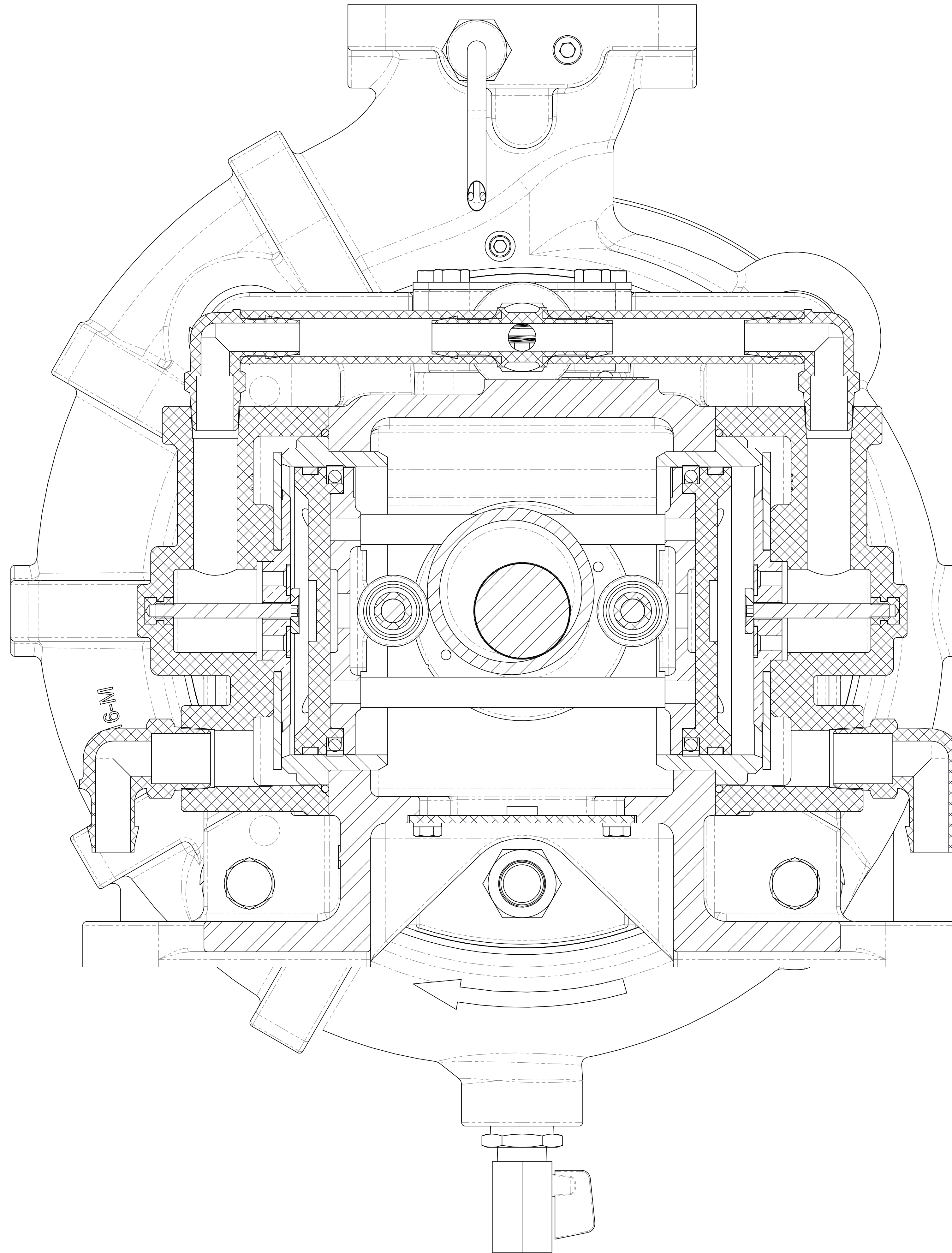

**Cross Section View - Through Primers**  
(See pages 2-3 for reference numbers)