



Document Number SPL83335	Issue Date 06/27/14	Rev Date 5/14/18
------------------------------------	-------------------------------	----------------------------

CRU-2 Series Pump Impeller Shaft Service Parts Lists

Index:

Pump Model	View	See Page
CRUC21-2 CRUQC-2	Exploded View	2, 3
	Cross Section View	4, 5
CRU-2 Direct Drive	Exploded View	6, 7
	Cross Section View	8, 9
All – Optional Impeller Inducer	Exploded View	10, 11

CRUC21-2 / CRUQC-2 Exploded View

REF NO.	DESCRIPTION
S1	Impeller Shaft (Includes oil seal sleeve from transmission assembly)
S2	Impeller
S3	Wear Ring (Available in Standard or .025, .050 and .075 Undersize)

REF NO.	DESCRIPTION
S4	Impeller Washer
S5	Impeller Nut
S6	Cotter Pin
S7	Mechanical Seal Kit
S8	Throttle Bushing
S9	Key

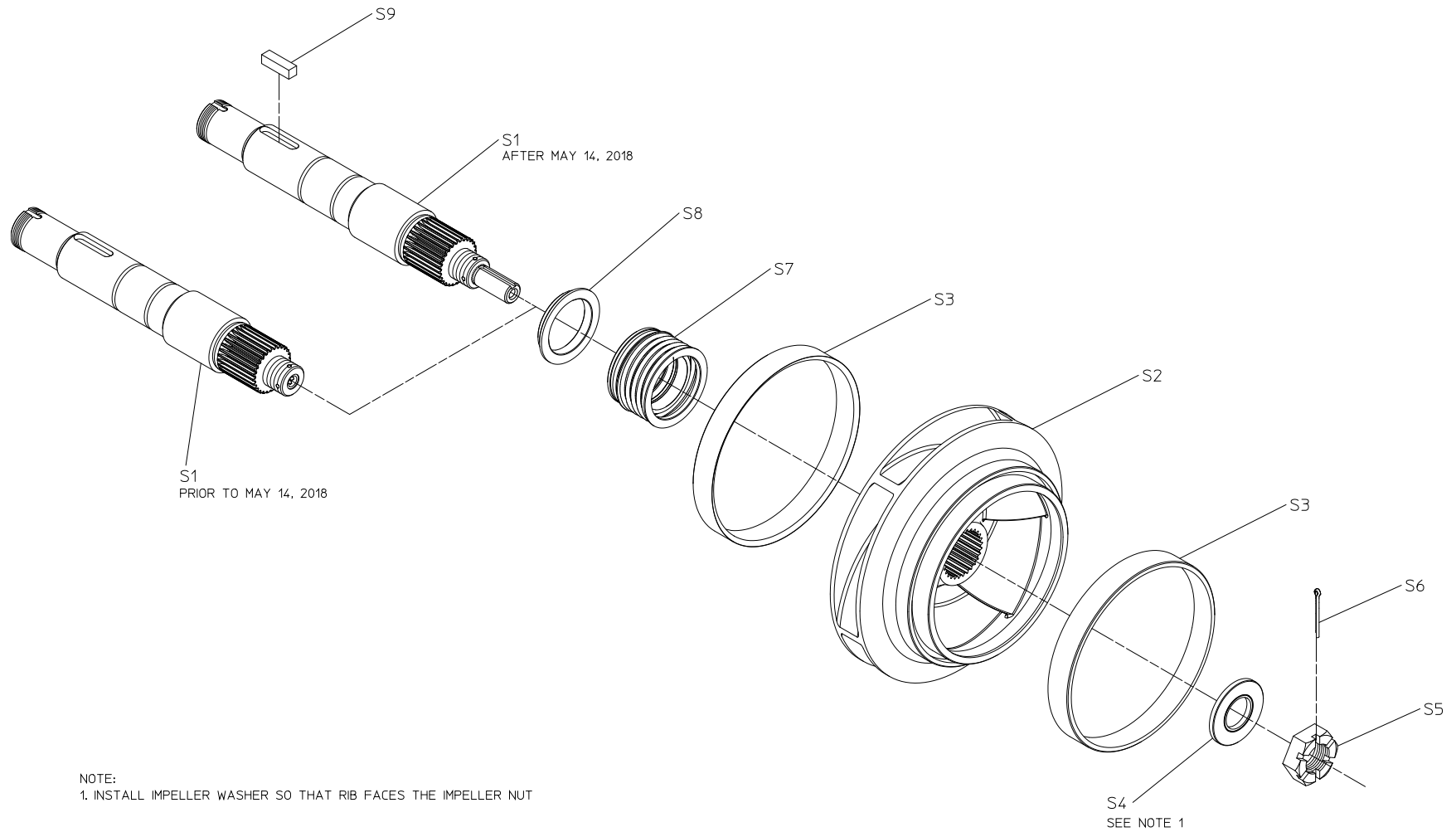

CRUC-2 & CRUC21-2 IMPELLER SHAFT ASSEMBLY

CRUC21-2 / CRUQC-2 Cross Section View

REF NO.	DESCRIPTION
S1	Impeller Shaft (Includes oil seal sleeve from transmission assembly)
S2	Impeller
S3	Wear Ring (Available in Standard or .025, .050 and .075 Undersize)

REF NO.	DESCRIPTION
S4	Impeller Washer
S5	Impeller Nut
S6	Cotter Pin
S7	Mechanical Seal Kit
S8	Throttle Bushing
S9	Key

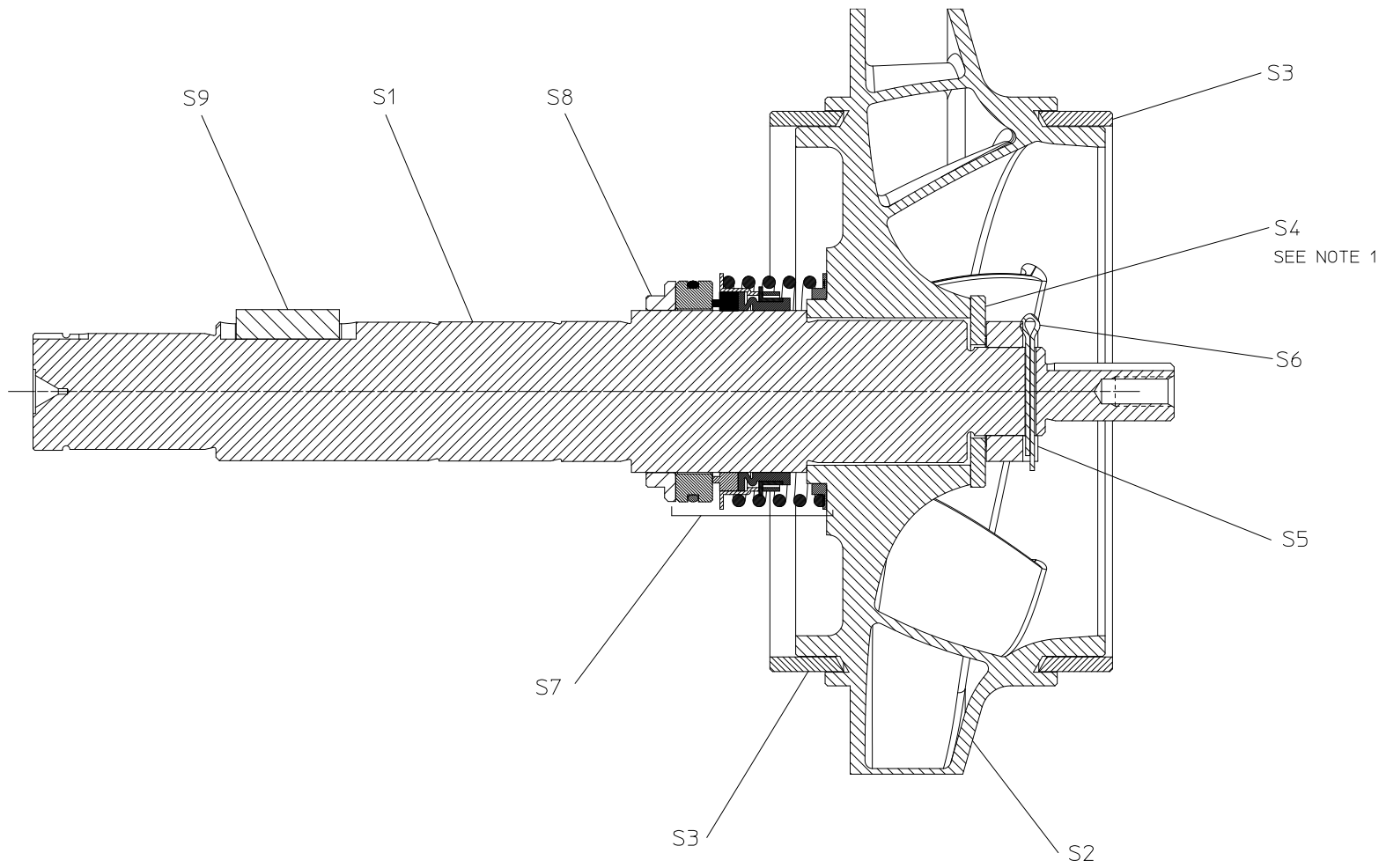

NOTE:
 1. INSTALL IMPELLER WASHER SO THAT RIB FACES THE IMPELLER NUT

CRUQC-2 & CRUC21-2 IMPELLER SHAFT ASSEMBLY

CRU-2 Direct Drive Exploded View

REF NO.	DESCRIPTION
S1	Impeller Shaft (Includes oil seal sleeve S18)
S2	Impeller
S3	Wear Ring (Available in Standard or .025, .050 and .075 Undersize)
S4	Impeller Washer
S5	Impeller Nut
S6	Cotter Pin
S7	Mechanical Seal Kit

REF NO.	DESCRIPTION
S8	Throttle Bushing
S10	Oil Seal
S11	Ball Bearing, Double Row
S12	Spacer, 4.797 in. wide
S13	Ball Bearing, Single Row
S14	Oil Seal Sleeve, 1.438 in. wide
S15	Oil Seal
S16	Washer, 1 in.
S17	Self-locking Nut, 1 in.
S18	Oil Seal Sleeve, 1.187 in. wide

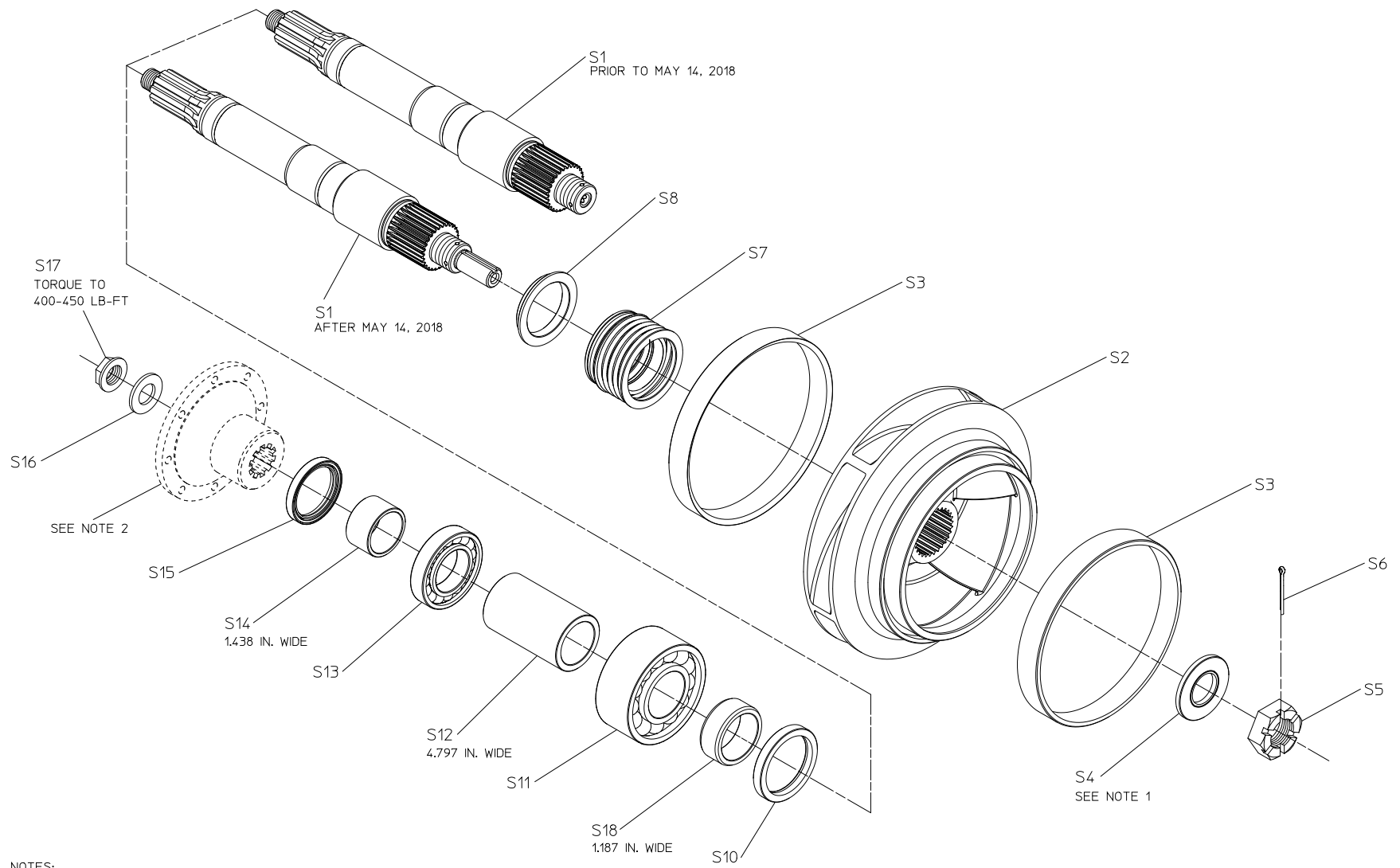

- NOTES:
1. INSTALL IMPELLER WASHER SO THAT THE RIB FACES THE IMPELLER NUT.
 2. COMPANION FLANGE OR END YOKE MAY NOT HAVE BEEN SUPPLIED BY WATEROUS.

CRU-2 DIRECT DRIVE IMPELLER SHAFT ASSEMBLY

CRU-2 Direct Drive Cross Section View

REF NO.	DESCRIPTION
S1	Impeller Shaft (Includes oil seal sleeve S18)
S2	Impeller
S3	Wear Ring (Available in Standard or .025, .050 and .075 Undersize)
S4	Impeller Washer
S5	Impeller Nut
S6	Cotter Pin
S7	Mechanical Seal Kit

REF NO.	DESCRIPTION
S8	Throttle Bushing
S10	Oil Seal
S11	Ball Bearing, Double Row
S12	Spacer, 4.797 in. wide
S13	Ball Bearing, Single Row
S14	Oil Seal Sleeve, 1.438 in. wide
S15	Oil Seal
S16	Washer, 1 in.
S17	Self-locking Nut, 1 in.
S18	Oil Seal Sleeve, 1.187 in. wide

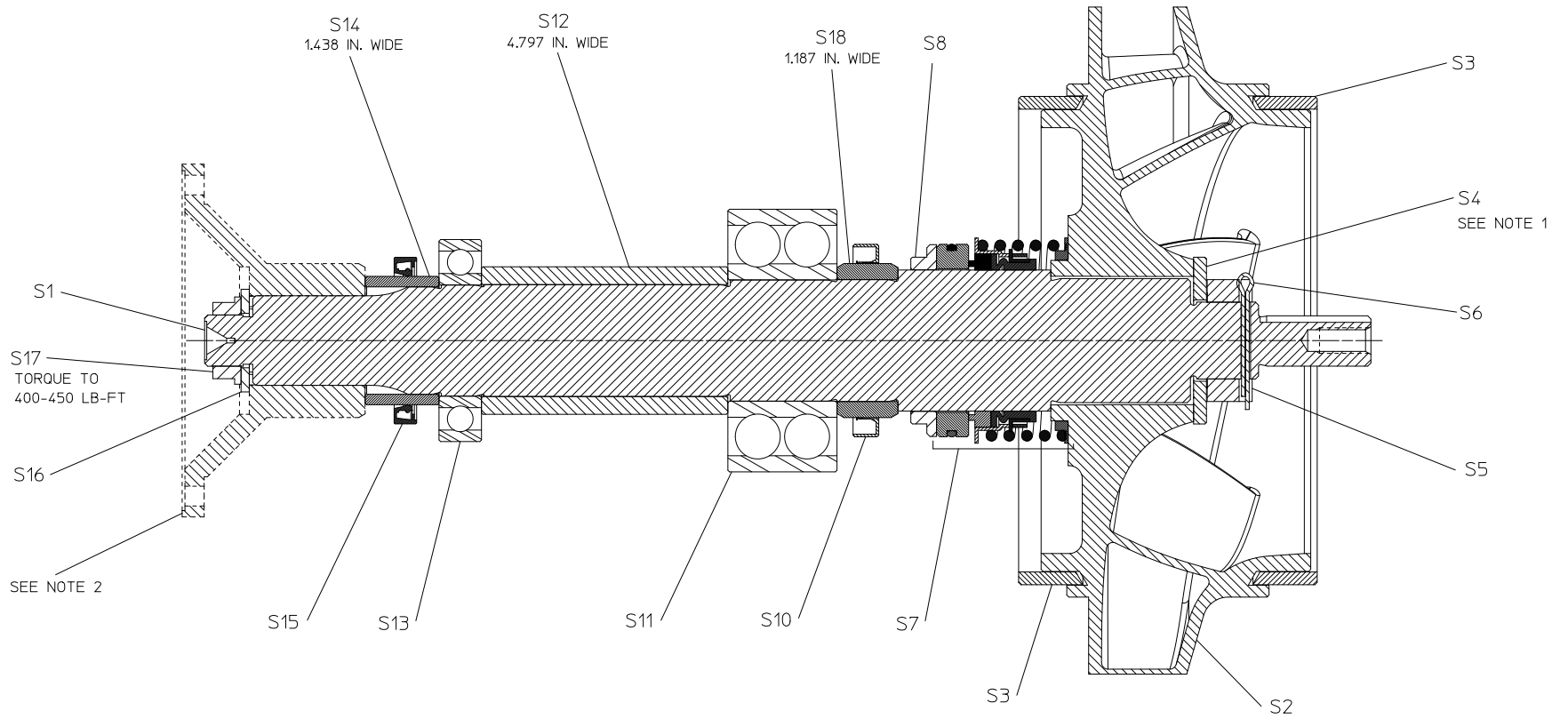

NOTES:

1. INSTALL IMPELLER WASHER SO THAT THE RIB FACES THE IMPELLER NUT.
2. COMPANION FLANGE OR END YOKE MAY NOT HAVE BEEN SUPPLIED BY WATEROUS.

CRU-2 DIRECT DRIVE IMPELLER SHAFT ASSEMBLY

CRU-2 Direct Drive Cross Section View

Impeller Inducer Exploded View

REF NO.	DESCRIPTION
S1	Impeller Shaft
S19	Square Key, 1/4 x 2
S20	Inducer
S21	Nord Lock Washer, 1/2
S22	Socket Head Screw, 1/2-13 x 3-1/2

REF NO.	DESCRIPTION

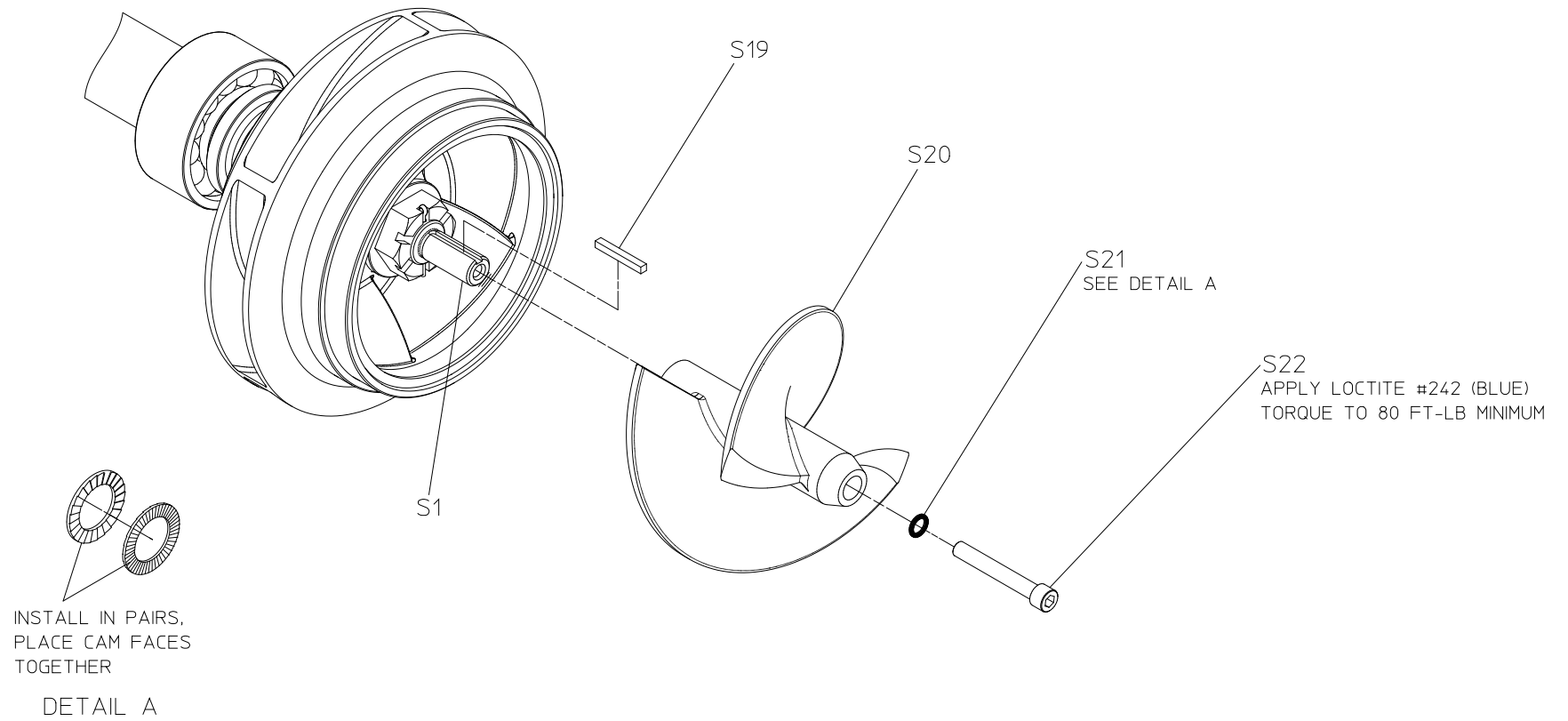

IMPELLER INDUCER