

Master Waterway Check Valve Service Parts List

Valve Manufacturer	Valve Size (in.)	Page
Akron	1.5	2
	2.0, 2.5, 3.0	3
Elkhart	1.5	4
	2.0, 2.5, 3.0	5

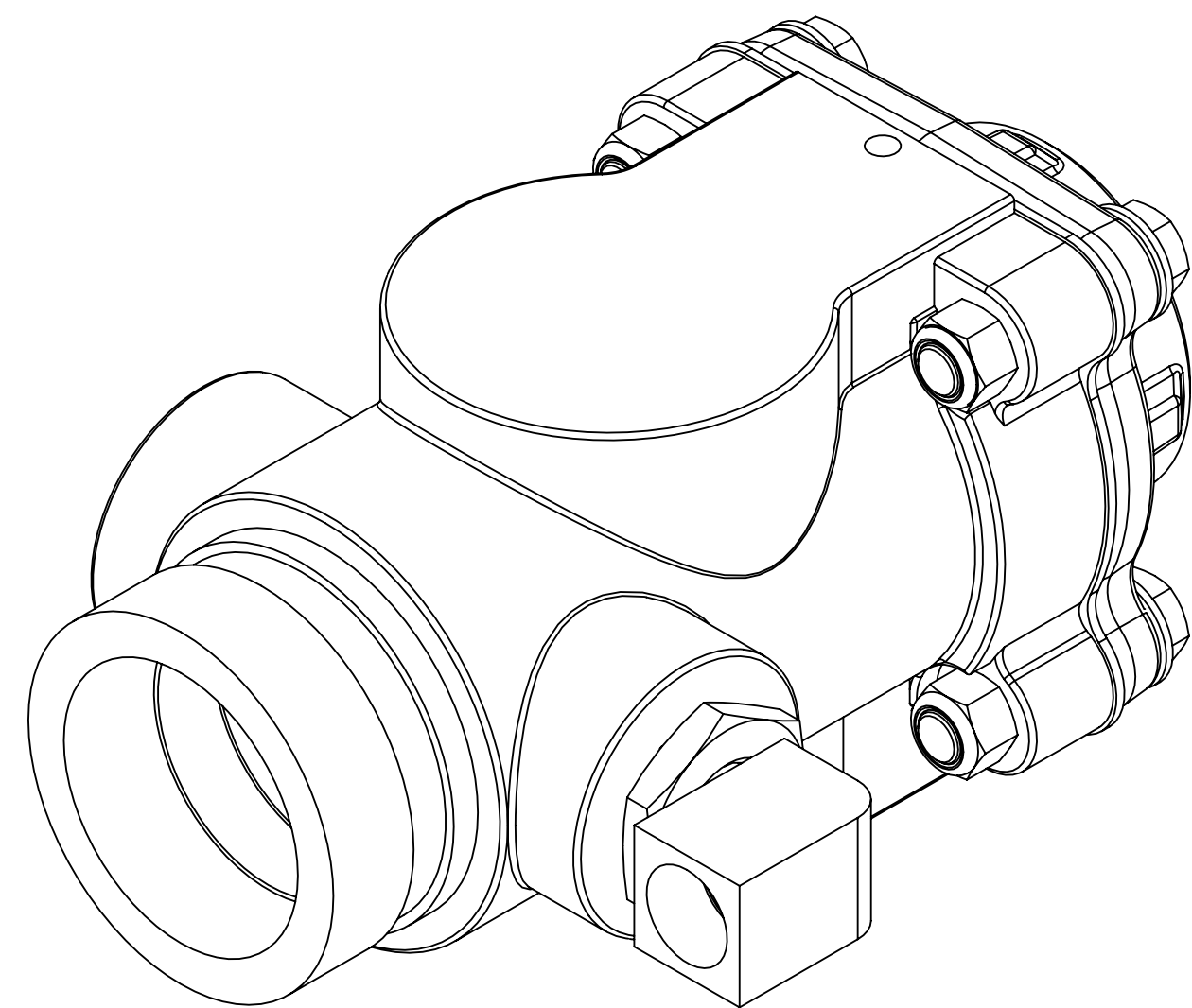

Ref No.	Description
450	Master Waterway Check Valve (Includes 451-458)
451	CHECK VALVE AKR 1.5 FNPT / VIC
452	FLANGE V1-S 1.5
453	Bushing, 3/4 MNPT x 3/8 FNPT
454	ELBOW-90 3/8 MNPT X 3/8 FNPT BRASS
455	GASKET, 1.5 AKRON FLANGE
456	SCREW-HEX HEAD, 5/16--18X 1-1/2, ZINC PLATED (COARSE THREAD)
457	Washer-Plain, 5/16 in
458	Nut-Hex, Nylok, 5/16-18

450
Master Waterway Check Valve
 (Includes 451-458)

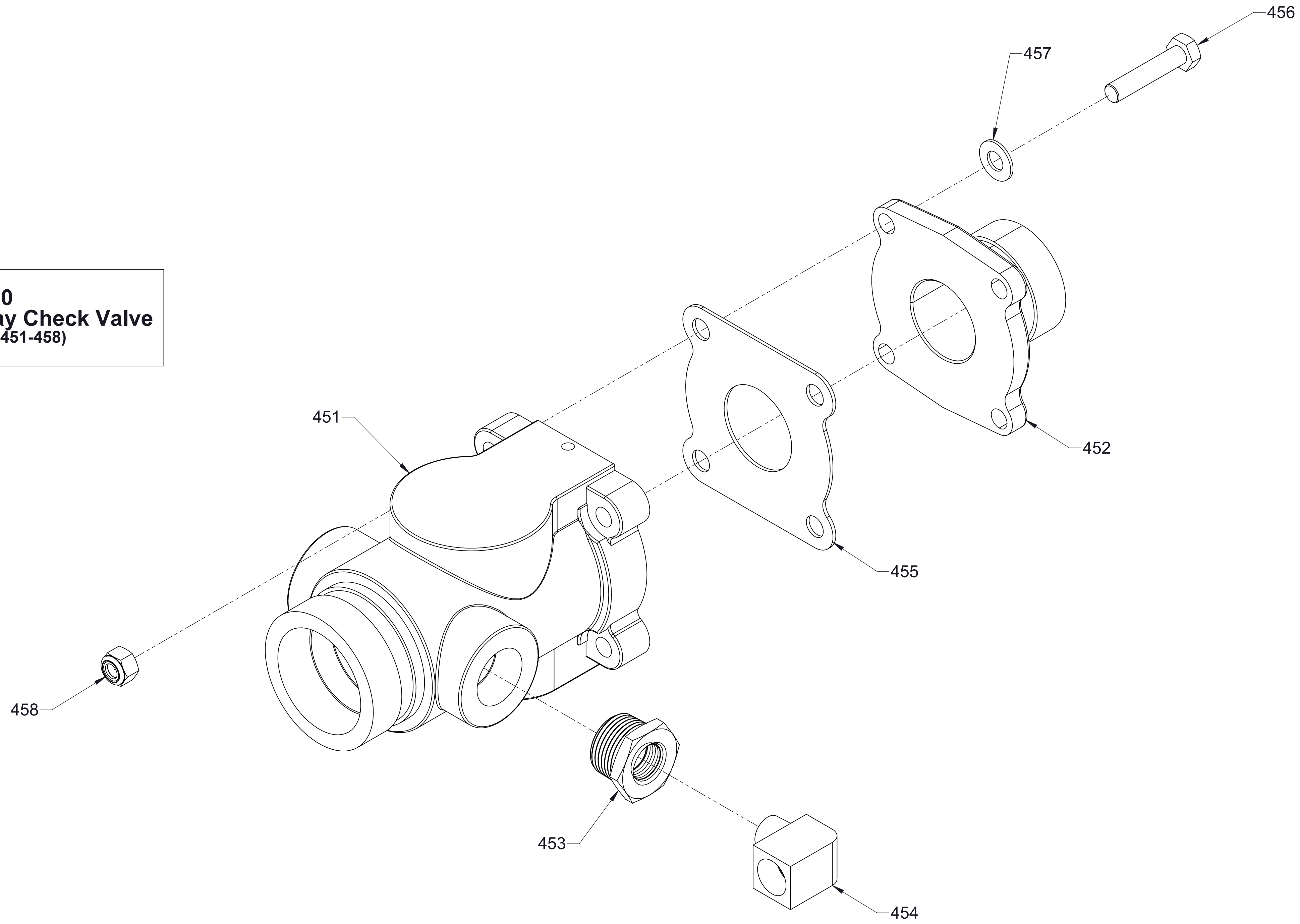

Akron Check Valve-1.5 in.

Ref No.	Description
450	Master Waterway Check Valve (Includes 451-459)
451	Check Valve, 2.0, 2.5, or 3.0 in
452	Flange-Adapter (Include 456 and 459)
453	Bushing, 3/4 MNPT x 3/8 FNPT
454	ELBOW-90 3/8 MNPT X 3/8 FNPT BRASS
456	Screw-Hex Hd, 3/8-16 x 1-1/2 in
457	Washer-Plain, 3/8 in

450
Master Waterway Check Valve
 (Includes 451-459)

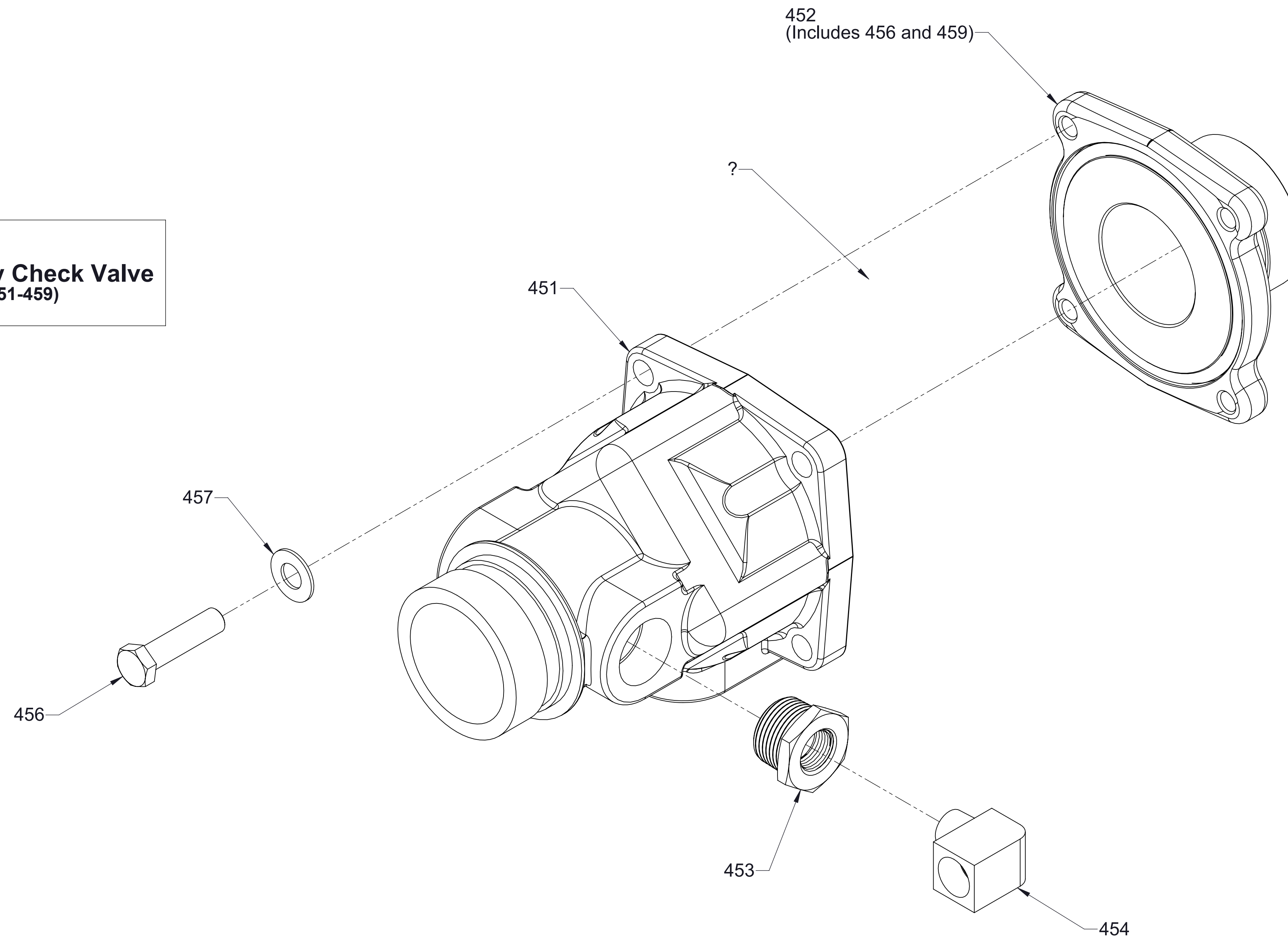

Akron Check Valve-2.0, 2.5, 3.0 in.

Ref No.	Description
450	Master Waterway Check Valve (Includes 451-458)
451	CHECK VALVE ELKHART, 1.5 UNI-BODY VALVE X 1.5 FNPT/2.0 VICTAULIC
452	ADAPTER, 1.5 UNI-BODY VALVE X 1.5 VICTAULIC
453	Bushing-Reducing, Pipe, 1 x 3/8 NPT
454	ELBOW-90 3/8 MNPT X 3/8 FNPT BRASS
455	GASKET, 2.0 AKRON FLANGE
456	Screw-Hex Hd, 5/16-18 x 1-3/4 in
457	Washer-Plain, 5/16 in
458	Nut-Hex, Nylok, 5/16-18

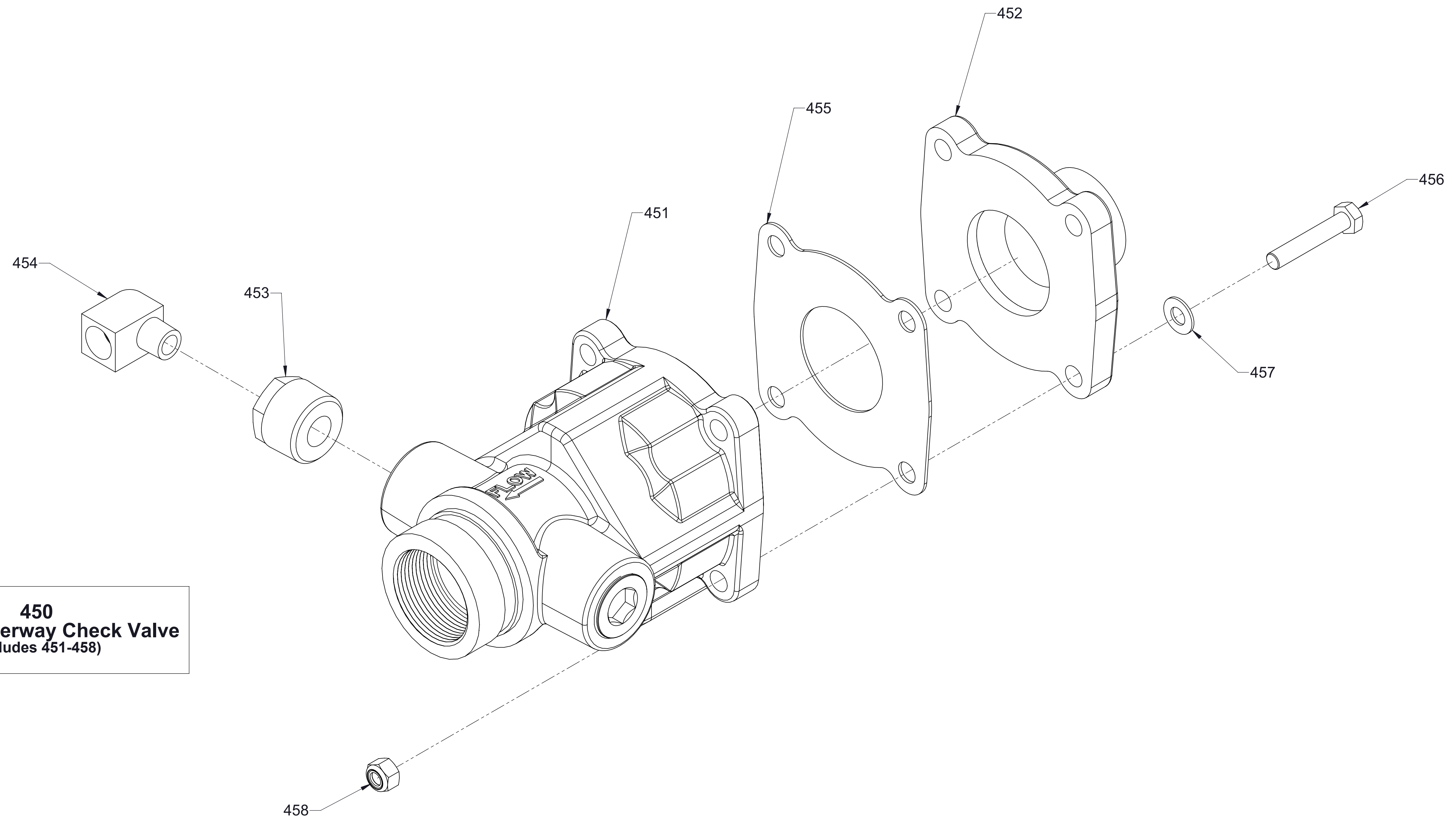

450
Master Waterway Check Valve
 (Includes 451-458)

Elkhart Check Valve-1.5 in.

Ref No.	Description
450	Master Waterway Check Valve (Includes 451-458)
451	Check Valve, 2.0, 2.5 or 3.0 in
452	ADAPTER, 2.0 UNI-BODY VALVE X 2.0 VICTAULIC
453	Bushing-Reducing, Pipe, 1 x 3/8 NPT
454	ELBOW-90 3/8 MNPT X 3/8 FNPT BRASS
455	GASKET, 2.0 AKRON FLANGE
456	Screw-Hex Hd, 3/8-16 x 2 in or 2-1/4 in
457	Washer-Plain, 3/8 in
458	Nut-Hex, Nylok, 3/8-16

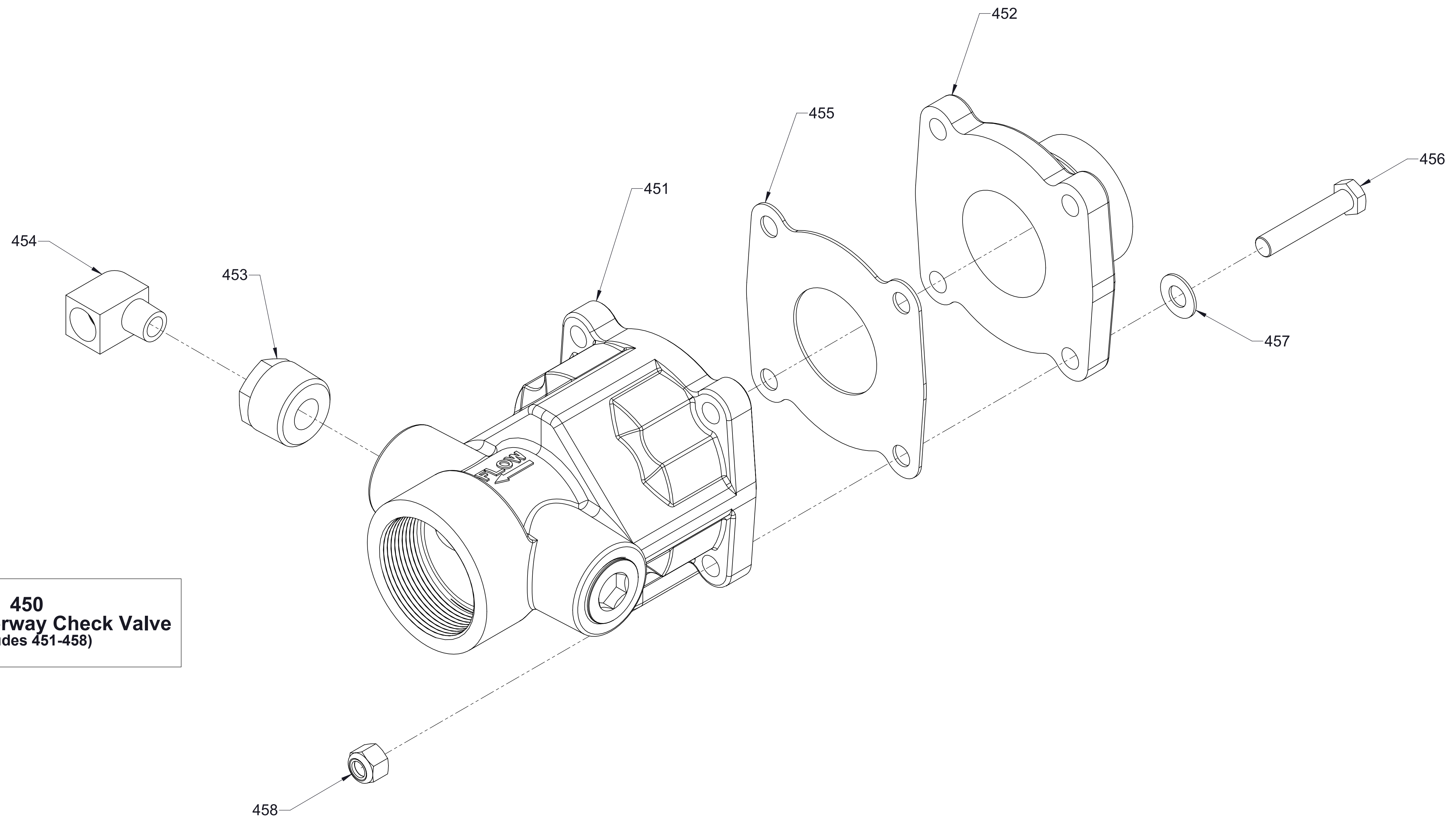

450
Master Waterway Check Valve
 (Includes 451-458)

Elkhart Check Valve-2.0, 2.5, 3.0 in.