

IL2510

### Table of Contents

<b>Safety Information</b> .....	1
Introduction .....	2
<b>General Description for Transmissions</b> .....	2
<b>General Description for Accessories</b> .....	2
<b>Shifting Instructions</b> .....	3
Pneumatic Pump Shift .....	3
Pneumatic Shift Manual Override .....	4
<b>Maintenance</b> .....	5
Indicating Lights Operation .....	5
Tachometer Readings .....	5
Fluid Levels .....	5
Shift Linkage .....	5
Pump Shift Troubleshooting Guide .....	6
Pump Transmission Shift Component Inspection .....	9

### Illustrations

TC10 PTO .....	2
Pneumatic Shift Manual Override .....	4



Read through the safety information and operating instructions carefully before using your Waterous PTO.

**WATEROUS**

*Fire Pumps – Since 1886*

**Visit us at [www.waterousco.com](http://www.waterousco.com)**

# Safety Information



Read through the safety information and operating instructions before using your Waterous PTO or Fire Pump.

## **WARNING**

Death or serious personal injury might occur if proper operating procedures are not followed. The pump operator, as well as individuals connecting supply or discharge hoses to the apparatus must be familiar with these pump operating instructions as well as other operating instructions and manuals for the apparatus, water hydraulics and component limitation.

## **WARNING**

### **Unexpected Truck Movement May result in serious personal injury or death**

Failure to properly shift transmission in accordance to the transmission operating instructions may result in unexpected truck movement which may result in serious personal injury or death.

## **WARNING**

If the truck attempts to move, reduce engine speed to idle. Put truck transmission in NEUTRAL and repeat shifting instructions.

## Introduction

The Waterous TC10 Chain Drive Transmission transmits power from the truck's drive line either to the fire pump or to the drive axle of the truck.

This instruction is divided into four sections:

- ▣ General Description for Transmissions
- ▣ General Description for Accessories
- ▣ Shifting Instructions
- ▣ Maintenance Instructions

Figure 1. TC10 Power Take-Off

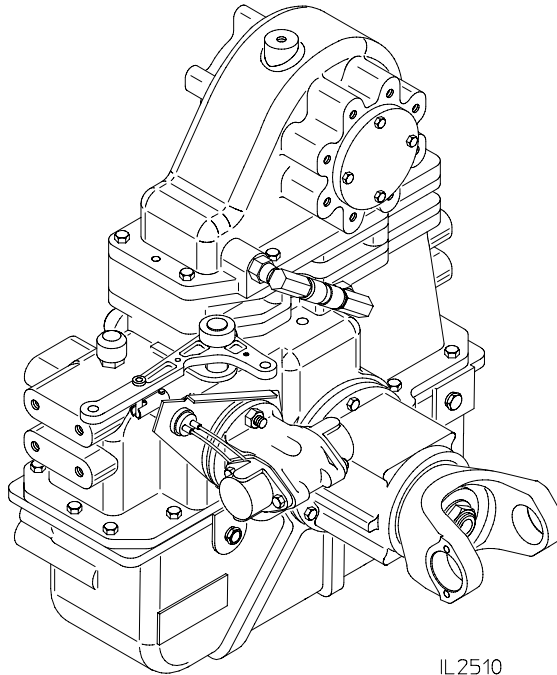

---

## General Description for Transmissions

---

The TC10 Series transmission is designed for use with Waterous fire pumps.

The bearings and drive chain are lubricated by a splash and passive lubrication system. Lubrication is accomplished when spray from the chain collects in a reservoir in the top of the case. The lubricant flows out of the reservoir, through a hose and onto the inside surface of the chain. This ensures all pivoting components of the chain receive lubrication.

An electronic tachometer connection protrudes from the tachometer housing at a 45° angle. This tachometer pick-up senses the drive shaft speed.

The shift mechanism within the transmission consists of a sliding internally-toothed collar which is always in engagement with an externally-toothed section of the drive shaft. A fork shifts the collar either to engage it with teeth on the drive sprocket hub (PUMP) or to engage it with the teeth

on the coupling shaft (ROAD). When in PUMP position, the shift collar transmits power from the drive shaft through the drive sprocket and the chain to the driven sprocket. The coupling shaft remains stationary. When in ROAD position, the shift collar transmits power directly from the drive shaft through the coupling shaft to the truck propeller shaft and drive axle(s). In this position, the pump drive and driven sprockets remain stationary while the drive shaft rotates.

Three shift indicator lights are furnished. Two are mounted in the cab and the other is mounted on the operators panel. These lights indicate to the operators that the shift has been completed into PUMP position and the truck transmission is in pumping gear.

---

## General Description for Accessories

---

The pneumatic shift assembly permits fast, positive shifting without leaving the cab. A two-position control, mounted on the instrument panel in the cab activates the shift unit. It is equipped with a complete set of lights that indicate when the shift has been fully completed to PUMP and the truck transmission is in PUMPING gear.

# Shifting Instructions

## Pneumatic Pump Shift

Two series of Allison automatic transmissions are commonly used in fire trucks. Each series is available with the shift patterns controlled hydraulically or both electronically and hydraulically. This later type is commonly referred to as the ATEC transmission.

In each automatic transmission, either the non-ATEC or the ATEC, certain sequences must occur in proper order after the pump shift control is moved to either PUMP or ROAD position.

Split shaft pump transmissions, automatic transmissions and engines will vary in operation due to manufacturing tolerances, lubrication temperature, etc. This variance in each may or may not affect the ease of completing a full shift into either PUMP or ROAD. Operator training and experience in shifting procedures is a requirement to becoming skilled in a smooth, complete shift into either PUMP or ROAD.

**When the pump shift is activated, the operator may hear a noise associated with the movement of the shift unit. This does NOT mean that the shift has been completed.**

After the shift to pump operation is completed, the green PUMP ENGAGED and OK TO PUMP lights in the cab must be on before leaving the cab to operate the pump from the operators panel. **DO NOT LEAVE THE CAB IF THE GREEN PUMP ENGAGED AND OK TO PUMP LIGHTS ARE NOT ON.**

Some truck builders may install a manual override for the pneumatic pump shift. The controls are normally installed from the pump transmission to the operators panel.

### WARNING

**Unexpected Truck Movement.  
May result in serious personal injury or death.**

Failure to properly shift the PTO in accordance to the PTO operating instructions may result in unexpected truck movement which may result in serious personal injury or death.

### **Shift to PUMP as follows:**

1. Bring truck to complete stop.
2. Reduce engine to idle speed, put truck transmission into **NEUTRAL**.
3. Set truck parking brake.
4. Move pump shift control to **PUMP** position.

**NOTE: Green PUMP ENGAGED light may not illuminate.**

5. Shift truck transmission into pumping gear (**DRIVE**).

### CAUTION

Shifting truck transmission into pumping gear (**DRIVE**) above engine idle speed may cause damage to the equipment.

6. Green PUMP ENGAGED and OK TO PUMP lights should be on.

### CAUTION

If green PUMP ENGAGED and OK TO PUMP light are not on, momentarily shift truck transmission from pumping gear (**DRIVE**) to **NEUTRAL**, then **REVERSE**, then **NEUTRAL**, then back into pumping gear (**DRIVE**). Lights should be on. If lights are not on, repeat procedure.

7. Increase engine speed above idle and hold for a few seconds. Watch speedometer to make sure it shows some value of road speed.

**NOTE: Some fire trucks have a speedometer that will not show a value of road speed in a stationary position.**

### WARNING

If the truck attempts to move, reduce engine speed to idle. Put truck transmission in **NEUTRAL** and repeat shifting instructions.

8. After leaving truck cab, block wheels using wheel chocks.
9. To confirm that the pump is engaged:
  - THROTTLE READY light on operator's panel is illuminated.
  - Pump discharge pressure registers on gages.
  - Other safety interlocks are activated.

### **Shift to ROAD as follows:**

1. With engine speed at idle, put truck transmission in **NEUTRAL**.
2. When speedometer slows to zero, move pump shift control to **ROAD** position.
3. Engage truck transmission (**DRIVE**).

### CAUTION

If you hear a loud grinding noise when you attempt to move the truck, the shift to **ROAD** has not been completed. Shift into **NEUTRAL**, wait for grinding noise to stop and re-engage truck transmission.

If grinding is a common occurrence after Step 3 is performed, it may be prevented by shifting the truck transmission into **NEUTRAL**, then to **REVERSE**, back to **NEUTRAL** and finally to **DRIVE**.

4. After shifting the truck transmission to **DRIVE**, release the parking brake and move the vehicle forward to confirm a shift to **ROAD** has been completed.

## Pneumatic Shift Manual Override

Two series of Allison automatic transmissions are commonly used in fire trucks. Each series is available with the shift patterns controlled hydraulically or both electronically and hydraulically. This later type is commonly referred to as the ATEC transmission.

In each automatic transmission, either the non-ATEC or the ATEC, certain sequences must occur in proper order after the pump shift control is moved to either PUMP or ROAD position.

Split shaft pump transmissions, automatic transmissions and engines will vary in operation due to manufacturing tolerances, lubrication temperature, etc. This variance in each may or may not affect the ease of completing a full shift into either PUMP or ROAD. Operator training and experience in shifting procedures is a requirement to becoming skilled in a smooth, complete shift into either PUMP or ROAD.

**When the pump shift is activated, the operator may hear a noise associated with the movement of the shift unit. This does NOT mean that the shift has been completed.**

After the shift to pump operation is completed, the green PUMP ENGAGED and OK TO PUMP lights in the cab must be on before leaving the cab to operate the pump from the operators panel. **DO NOT LEAVE THE CAB IF THE GREEN PUMP ENGAGED AND OK TO PUMP LIGHTS ARE NOT ON.**

If the vehicle builder has provided a means to manually override the pneumatic pump shift, the override control will be located at the operators panel or in the cab. The override control will consist of a rod to the panel or a cable or rod mechanism to the inside of the cab. The rod or cable will be attached to the shift arm on the pump transmission.

**NOTE: This instruction is written based on an override control rod directed to the operators panel from the short arm of the lever on the PTO. Other rod or cable arrangements may require reversal of stated action to accomplish the desired shift.**

Figure 2. Pneumatic Shift Manual Override

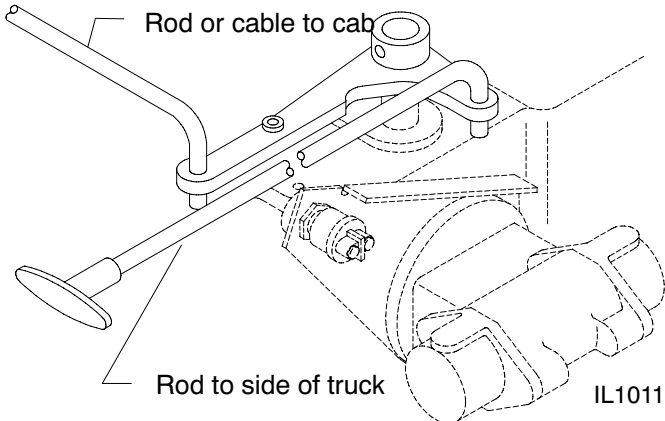

If the PTO is equipped with an override, shifting manually is done as follows:

It is recommended that this procedure be performed using two people; one person in the cab and one at the override control position.

### ⚠ WARNING

**Unexpected Truck Movement.  
May result in serious personal injury or death.**

Failure to properly shift the PTO in accordance to the PTO operating instructions may result in unexpected truck movement which may result in serious personal injury or death.

### Shift to PUMP as follows:

1. Bring truck to complete stop.
2. Reduce engine to idle speed, put truck transmission in **NEUTRAL**.
3. Set truck parking brake.
4. Move in-cab pump shift control into the **CENTER** position.
5. Push manual shift control rod in for **PUMP** position.
6. Move the in-cab pump shift control into the **PUMP** position.
7. Green PUMP ENGAGED light should be on.

### CAUTION

If green PUMP ENGAGED light is not on, momentarily shift truck transmission into REVERSE while keeping pressure on the manual shift rod. Return to NEUTRAL. Green PUMP ENGAGED light should be on.

8. Shift truck transmission into pumping gear (**DRIVE**).

### CAUTION

Shifting truck transmission into pumping gear (DRIVE) above engine idle speed may cause damage to the equipment.

9. Green OK TO PUMP light should be on.
10. Increase engine speed above idle and hold for a few seconds. Watch speedometer to make sure it shows some value of road speed.

**NOTE: Some fire trucks have a speedometer that will not show a value of road speed in a stationary position.**

### ⚠ WARNING

If the truck attempts to move, reduce engine speed to idle. Put truck transmission in NEUTRAL and repeat shifting instructions.

11. After leaving truck cab, block wheels using wheel chocks.
12. To confirm that the pump is engaged:
  - THROTTLE READY light on operator's panel is illuminated.
  - Pump discharge pressure registers on gages.
  - Other safety interlocks are activated.

### Shift to ROAD as follows:

1. With engine at idle speed, put truck transmission in **NEUTRAL**.
2. When speedometer drops to zero, move in-cab pump shift control into the **CENTER** position.
3. Pull manual shift rod out for **ROAD** position.
4. Move the in-cab PTO shift control into the **ROAD** position.
5. Engage truck transmission (**DRIVE**).

### CAUTION

If you hear a loud grinding noise when you attempt to move the truck, the shift to ROAD has not been completed. Shift into NEUTRAL, wait for grinding noise to stop and re-engage truck transmission, while keeping pressure on the manual shift control rod.

6. After shifting the truck transmission to **DRIVE**, release the parking brake and move the vehicle forward to confirm a shift to **ROAD** has been completed.

## Maintenance

### Indicating Lights Operation

Check the operation of the pump shift indicating lights at least weekly as follows:

**NOTE: Block wheels with wheel chocks before beginning.**

1. With the PTO in the ROAD position, truck transmission in NEUTRAL and the parking brake engaged, ensure that the PUMP ENGAGED and OK TO PUMP lights in the cab are off.
2. Shift to PTO following the shifting instructions section of this document.
  - a. Ensure that the green PUMP ENGAGED and OK TO PUMP lights in the cab are on.
  - b. Ensure that the green THROTTLE READY light on the operator's panel is on.
3. Apply the service (foot) brake and release the parking brake.
  - a. Ensure that the green OK TO PUMP light in the cab is off.
  - b. Ensure that the green THROTTLE READY light on the operator's panel is off.
4. Engage the parking brake and shift PTO to NEUTRAL.
  - a. Ensure that the green OK TO PUMP light in the cab is off (automatic truck transmission only).
5. Shift to ROAD following the shifting instructions section of this document.
  - a. Ensure that the green PUMP ENGAGED and OK TO PUMP lights in the cab are off.
  - b. Ensure that the green THROTTLE READY light on the operator's panel is off.

### Tachometer Readings

#### Mechanical Tachometer:

Speed of drive tachometer gear is 1/2 of input shaft speed.

#### Electric Tachometer:

To verify input shaft speed, take a frequency reading from the tachometer sensor. Multiply frequency reading (Hz) by 1.5 for shaft speed. The impeller shaft speed can be calculated by multiplying the input shaft speed by the ratio of the pump transmission.

### Fluid Levels

1. Check fluid level monthly by removing fluid level plug at rear of case. The fluid should be level with bottom of hole.

A sight plug is also provided for this purpose, and the fluid level should be visible thru this plug.

### CAUTION

If fluid level is low, locate source of leak and repair. If fluid level is high, loosen drain plug until fluid drops to proper level. If excessive water drains out, change fluid and determine source of water leakage and repair.

**NOTE: Fluid temperature should not exceed 250°F for an extended period of time or premature seal wear and damage may occur.**

Fluid can be added thru the fluid level hole or by removing the breather and adding fluid thru this opening. Any type of automatic transmission fluid (ATF) can be used.

2. Change fluid twice per year or after each 100 hours of operation, whichever comes first. Clean the breather and magnetic drain plug thoroughly whenever the transmission fluid is changed.

### Amount required if system is drained and refilled

**12 quarts (approximately)**

### Shift linkage

Periodically check all shift linkage for freedom of movement and clean as necessary.

## Pump Shift Troubleshooting Guide

It is important to know what to do if you experience shifting problems with your pump. This troubleshooting guide will help you diagnose, isolate and correct problems as they are encountered.

For problems not covered in this guide, or for additional technical assistance, please contact the Waterous Service Department.

Problem	Is the chassis transmission in DRIVE (automatic) or in its pump gear (Manual)?	Possible Cause		Recommended Action
		Pneumatic Shift	Electric Shift	
<p><b>Pump won't engage</b></p> <p>Pump shift control is in the PUMP position and:</p> <p>1. No lights or Red light stays on or flashed (units built prior to 1991).</p> <p>or</p> <p>2. PUMP ENGAGED light does not come on (units built 1991 or newer).</p>	No	Butt-tooth condition	Butt-tooth condition	Place the chassis transmission in Drive (automatic) or in its pumping gear (manual).
	Yes	Malfunctioning shift indicating switch or switch out of adjustment	Malfunctioning shift indicating switch or switch out of adjustment	Replace or adjust the shift indicating switch or bracket.
		Manual override linkage binding	Manual override linkage binding	Repair or replace to eliminate binding.
		Excessive driveline torque	Excessive driveline torque	Shift the chassis transmission into REVERSE momentarily, then NEUTRAL, then DRIVE. ----- Consider reducing engine idle speed. ----- It may be necessary to contact the chassis transmission manufacturer for assistance.
		Low air pressure to pneumatic shift unit (80 psi min.)	--	Allow air pressure to build in the system, repair any leaks in the system.
		Leaking pneumatic shift unit.	--	Repair or replace pneumatic shift unit.
		Malfunctioning air control valve	--	Repair or replace air control valve.
		--	No power to shift unit.	Repair as needed to restore power supply.
		--	Failed shift motor - check current draw, should be 20A at startup and 10A through the cycle.	Replace the shift motor.
		--	Failed shift unit - unit has power and draws correct amperage but will not activate.	Repair or replace the electric shift unit.



Problem	Is the PUMP ENGAGED light on?	Possible Cause		Recommended Action
		Pneumatic Shift	Electric Shift	
<p><b>Pump will not engage and there is a grinding noise emanating from the pump transmission.</b></p> <p>Pump shift control is in the PUMP position and:</p> <p>1. The chassis transmission is in DRIVE (automatic) or in its pumping gear (manual).</p> <p>or</p> <p>2. The chassis transmission is in NEUTRAL.</p>	No	Manual override linkage binding.	Manual override linkage binding.	Repair or replace to eliminate binding.
		Excessive driveline torque.	Excessive driveline torque.	Shift the chassis transmission into REVERSE momentarily, then NEUTRAL, then DRIVE. ----- Consider reducing engine idle speed. ----- It may be necessary to contact the chassis transmission manufacturer for assistance.
		Low or no air pressure to pneumatic shift unit (80 psi min.)	--	Allow air pressure to build in the system, repair any leaks in the system.
		--	Weak shift unit or non-Waterous supplied shift unit.	Replace shift unit with a high-torque shift unit provided by Waterous.
		Damage to internal pump transmission shifting components.	Damage to internal pump transmission shifting components.	See pump transmission inspection instructions.
	Yes	Shift indicating switch is out of adjustment or its bracket is damaged.	Malfunctioning shift indicating switch or switch out of adjustment.	Adjust the shift indicating switch or replace the bracket.
		Damage to internal pump transmission shifting components.	Damage to internal pump transmission shifting components.	See pump transmission inspection instructions.
<p><b>Chassis engine stalls after placing the pump shift control in PUMP and placing the chassis transmission in DRIVE (automatic) or in its pumping gear (manual).</b></p>	No	Pump transmission has not shifted out of ROAD due to excessive driveline torque.	Pump transmission has not shifted out of ROAD due to excessive driveline torque.	Shift the chassis transmission into REVERSE momentarily, then NEUTRAL, then DRIVE. ----- Consider reducing engine idle speed. ----- It may be necessary to contact the chassis transmission manufacturer for assistance.
		Damage to internal pump transmission shifting components.	Damage to internal pump transmission shifting components.	See pump transmission inspection instructions.
	Yes	Seized fire pump.	Seized fire pump.	Repair fire pump as necessary.



Problem	Is the chassis transmission in DRIVE (automatic) or in its pump gear (Manual)?	Possible Cause		Recommended Action
		Pneumatic Shift	Electric Shift	
<b>PUMP ENGAGED light is on but OK TO PUMP light will not illuminate.</b>  (Units built 1991 and later)	No	Chassis transmission not in the proper gear.	Chassis transmission not in the proper gear.	Place the chassis transmission in DRIVE (automatic) or in its pumping gear (manual).
	Yes	Parking brake is not applied.	Parking brake is not applied.	Apply the parking brake.
		Problem with high range lockup or safety interlock systems.	Problem with high range lockup or safety interlock systems.	Contact the apparatus manufacturer or consider alternative wiring for high range lockup.
		Problem with chassis transmission or transmission electronic control unit.	Problem with chassis transmission or transmission electronic control unit.	Contact the chassis transmission manufacturer for assistance.

Problem	Is the Pump transmission shift arm in contact with the shift indicating switch?	Possible Cause		Recommended Action
		Pneumatic Shift	Electric Shift	
<b>Pump shift control is in the ROAD position, but the PUMP ENGAGED and/or OK TO PUMP lights stay on.</b>  Note: Chassis engine may stall if the chassis transmission is placed in DRIVE (automatic) or in its pumping gear (manual).	No	Shift indicating switch stuck closed.	Shift indicating switch stuck closed.	Replace the shift indicating switch.
	Yes	Locking arm assembly is installed backwards inside pump transmission (the shift arm should move away from the shift indicating switch when shifting to pump).	Locking arm assembly is installed backwards inside pump transmission (the shift arm should move away from the shift indicating switch when shifting to pump).	Remove locking arm assembly and re-install correctly.

Problem	Possible Cause		Recommended Action
	Pneumatic Shift	Electric Shift	
<b>Pump shift control is in the ROAD position and grinding sounds are heard emanating from the pump transmission.</b>	Chassis transmission is in gear when shifting pump.	Chassis transmission is in gear when shifting pump.	Place the chassis transmission in NEUTRAL before shifting pump transmission.
	Butt-tooth condition - chassis transmission is in REVERSE.	Butt-tooth condition - chassis transmission is in REVERSE.	Place the chassis transmission in DRIVE after shifting pump transmission to ROAD.
	Excessive driveline torque and/or rotation.	Excessive driveline torque and/or rotation.	Ensure the driveline is not rotating before shifting to ROAD. ----- Consider reducing engine idle speed. ----- It may be necessary to contact the chassis transmission manufacturer for assistance.
	Damage to pump transmission shifting components.	Damage to pump transmission shifting components.	See pump transmission inspection instructions.
<b>Manual pump shift override control cannot be moved by hand (electric or pneumatic shift functions properly).</b>	Air pressure present on pneumatic shift piston.	--	Place the shift air control valve in the center position. (Note: There is no center position on units built prior to 1994).
	--	Electric shift still engaged with shift arm.	Operate the electric shift to disengage control.
	Binding or malfunctioning manual shift linkage.	Binding or malfunctioning manual shift linkage.	Repair or replace to eliminate linkage binding.
<b>The chassis engine stalls when the chassis transmission is placed in DRIVE (automatic) after moving the pump shift control to the ROAD position.</b>	Shift indicating switch stuck closed.	Shift indicating switch stuck closed.	Replace the shift indicating switch.
	Problem with chassis transmission or transmission electronic control unit.	Problem with chassis transmission or transmission electronic control unit.	Contact chassis transmission manufacturer for assistance.

### ***Pump Transmission Shift Component Inspection***

The following procedures should be followed when a problem with the pump transmission shift components is suspected:

1. Perform a shift force test on the pump transmission.
  - a. Place the chassis transmission in NEUTRAL and shut off the engine.
  - b. Set the apparatus parking brake.
  - c. Remove any manual override linkage from the pump transmission shift arm.
  - d. Remove the pneumatic or electric shift unit (if so equipped) from the pump transmission.
- e. Manually align the shift teeth by actuating the pump transmission shift arm and rotating the drive shaft until the shift collar is engaged in the PUMP position.
- f. Pull on the long side of the shift arm to shift the pump transmission between ROAD and PUMP using a pull scale to measure the force required in pounds. The force required to shift the pump transmission should not exceed 18 pounds.
2. Drain the lubricant from the pump transmission and examine it for metal particles appearing in quantity and/or size which may indicate excessive wear to internal components. Also check the magnetic drain plug and the sump screen on the lube pump intake line (if so equipped) for debris. If there is little or no

debris refill with clean lubricant and retest. If the problem persists or if large quantities or sizes of debris are found proceed to step 3.

3. Remove the lower section of the pump transmission according to the pump transmission overhaul instructions.
4. Inspect the pump transmission shift components, including:
  - a. Check for damage to the shift fork and the shift shoes.
  - b. Check for damage to the shift shaft, locking arm assembly and sector gear.

- c. Check for damage to the engaging teeth on the drive sprocket, coupling shaft and shift collar.  
Note: it will be necessary to manually actuate the shift arm to inspect all of the teeth. Some binding may normally occur when actuating the shift arm with the lower case section removed). Minor burrs found on the teeth of the shift collar, drive sprocket, or coupling shaft may be filed clean. If excessive damage is found the component(s) should be replaced.
  - d. Check to make sure that all bearings turn freely.
5. Contact Waterous to order any replacement parts or for further assistance.