



2022 CORPORATE SIREN

THE FORCE BEHIND THE FIGHT

THE ANATOMY OF A WELL-BUILT PUMP

- A Focused Company
- What Makes Waterous Different
- Superior Customer Service

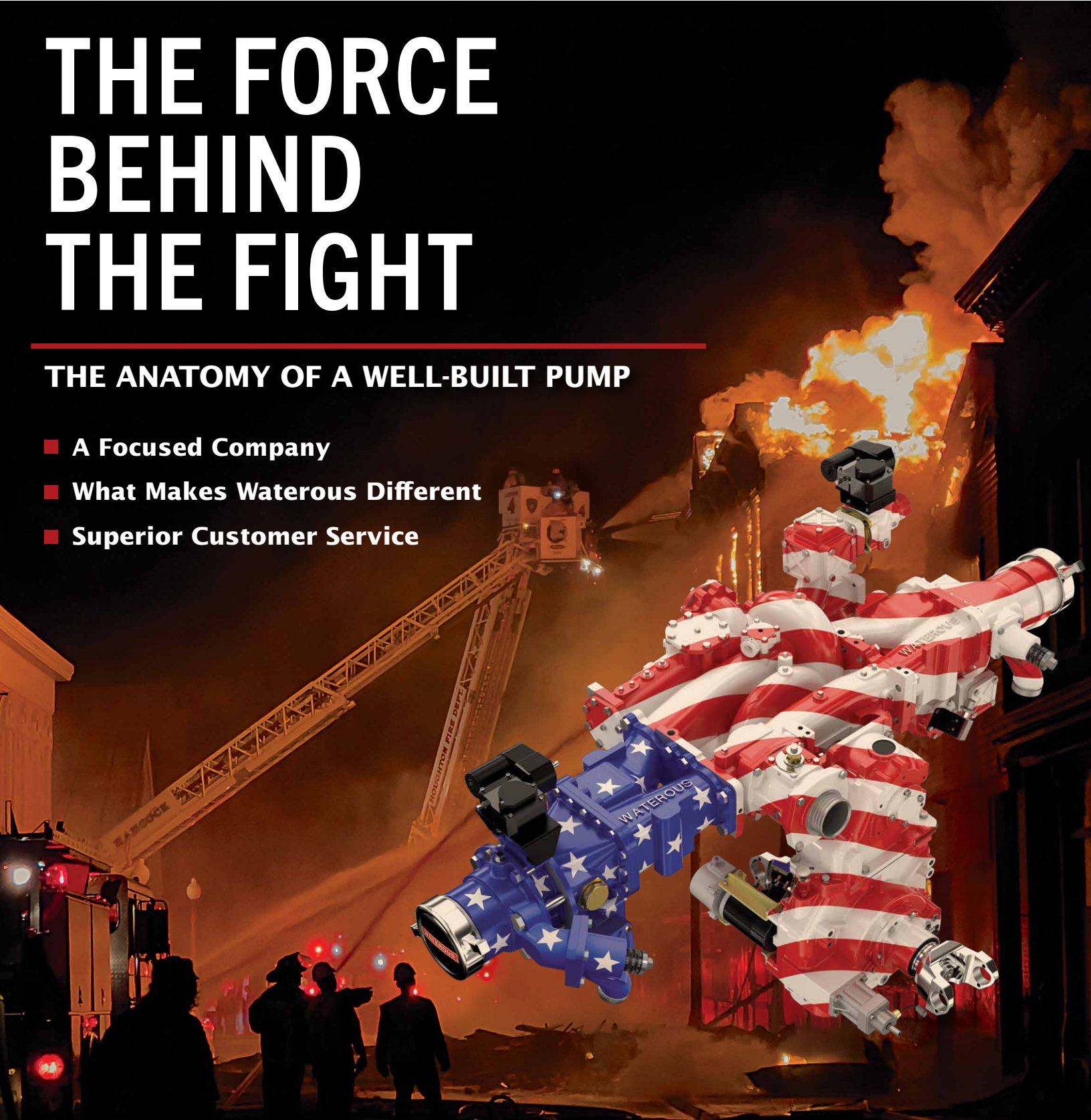

YOUR WATEROUS SALES REPRESENTATIVE



Jason Nawrocki - Sales Manager

Jason started at Waterous in 1999 working in hydrant assembly following four years of active duty in the United States Air Force. In 2007 Jason accepted the position of Pump Applications Specialist moving from the factory to the office.

After completing his bachelor's degree in Business, he became an OEM Sales Manager and now more recently serves as the Sales Manager for North America. In this position Jason leads and supports a team of five Sales Managers, responsible for the North America Fire market.

Jason states, "With the various roles I've been blessed to be able to serve in over the years within our amazing industry, I feel as though I bring a balanced approach and perspective which will enable Waterous to continue to serve our customers with the very best service and sales support possible, because that is exactly what our customers deserve."

With his Pump Applications background, Jason is willing and able to help answer questions on any of your fire suppression needs.

On his downtime, Jason enjoys spending time with his wife and two daughters in the outdoors in his home state of Minnesota. Jason also dabbles in Ironman 140.6 & 70.3 Triathlons

jmnawrocki@waterousco.com
Waterous Company
125 Hardman Ave S
South St Paul, MN 55075-1191

TABLE OF CONTENTS

A Focused Company	3
Waterous Product Line	5
Anatomy of a Well-Built Pump	6
Waterous Key Features	8
Superior Customer Service	10
USA MADE	11



A LETTER FROM OUR PRESIDENT



Dan Reese, President & CEO

As Waterous enters our 136th year of business in Minnesota, we are proud to be making the same products and serving the same industries as we were when Waterous was founded in 1886. Waterous' sole focus in the fire service is on providing you with the best pumping system, for the heart of your apparatus. We are so confident in our designs and assembly technicians that we stand behind our pumps with Waterous' industry-leading 7-year standard warranty.

Waterous also believes in longevity, our pump assembly workforce has a minimum of 25 years' experience before ever assembling your pump. Not only are our products built to last, but so is our highly trained workforce. Our senior pump service technicians have over 40-years of experience taking care of you, our customer, by providing parts and information when needed. All of this coupled with our Made in the USA supply chain, and our in-house machining capabilities keep your pump part orders shipping 95% of the time in 24 hours.

Made in the USA is something Waterous doesn't take lightly. To build the best products we need the best designed and sourced components. For Waterous, that means Made in the USA; cast, machined, assembled, and tested. This is Waterous' commitment to the fire service. Keep the supply chain short with local vendors that can be visited regularly, machine the parts here for maximum control, assemble and test the products here to create the highest quality in the industry. Waterous lives by the golden rule. Our designs, quality, delivery and service are our commitment on how to treat the fire service as we would want to be treated.

A FOCUSED COMPANY

From 1886 to 1929, Waterous built entire apparatus. Since 1929, we have focused only on building the highest quality, best performing pumps in the industry. We don't sell gear or apparatus. So, when you talk to Waterous, you can be guaranteed that you will be talking to the "Pump Guys". That focus also allows Waterous to invest in the latest machinery and software that will continue to increase the quality and efficiencies of our pumps now and into the future.

Made vs. Assembled in the USA

At Waterous, we talk a lot about being Made in the USA. Waterous is Made in the USA. But what does it mean to actually be 'Made in the USA' verses 'Assembled in the USA'?

Requirement for 'Made in USA' - Product advertised as Made in USA must be 'all or virtually all' made in the U.S. All or virtually all means that all significant parts and processing that go into the product must be of U.S. origin. That is, the product should contain no — or negligible foreign content. The policy goes on to clarify that a 'product that is all or virtually all made in the United States will ordinarily be one in which all significant parts and processing that go into the product are of U.S. origin.

Requirements for 'Assembled in USA' - Product that includes foreign components may be called 'Assembled in USA' without qualification when its principal assembly takes place in the U.S. and the assembly is substantial. For the 'assembly' claim to be valid, the product's last 'substantial transformation' also should have occurred in the U.S.

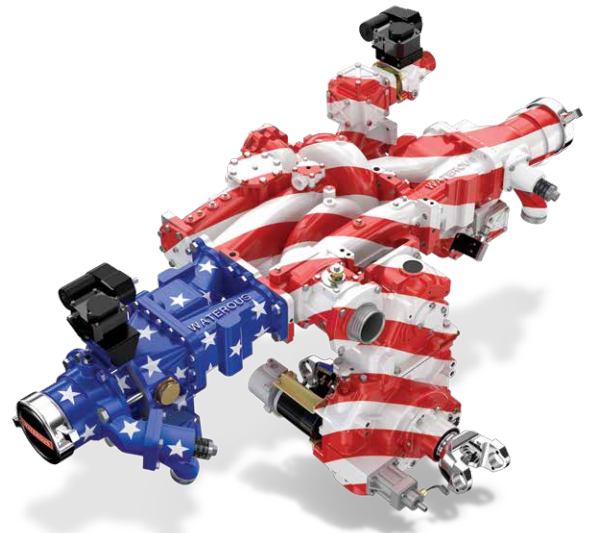



MIKE WEINBERG - PRODUCT MANAGER - FIREFIGHTER - VICTORIA, MN



At Waterous many of our employees serve on their local fire departments. From factory workers, project managers, customer service personnel and the Director of Sales, their experiences help us understand what it's like to battle a blaze while entrusting your life to a piece of equipment. It's a mindset we apply to every one of our products.

WE ARE WATEROUS. WE ARE FIREFIGHTERS.

FIRE PUMPS • FOAM SYSTEMS • CAFSYSTEMS™



waterousco.com

WATEROUS PRODUCT LINE

SPLIT-SHAFT PUMPS

500 to 2250 GPM
2000 to 9000 L/min

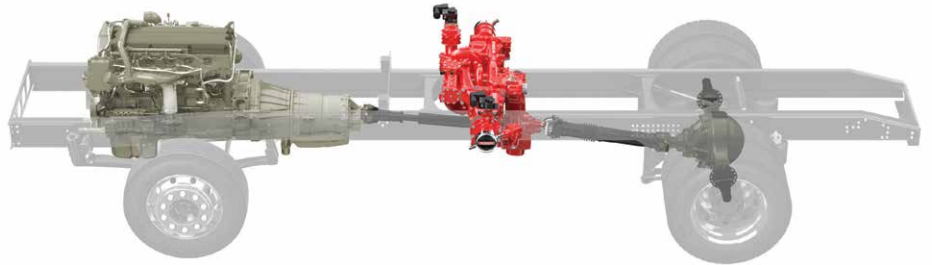
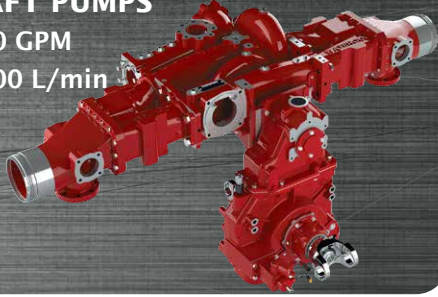

PTO-DRIVEN PUMPS

300 to 1500 GPM
1000 to 6000 L/min



REAR-MOUNTED PUMPS

100 to 2000 GPM
400 to 7500 L/min

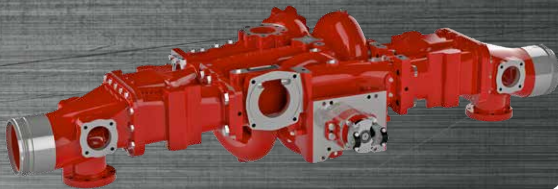

DIRECT ENGINE-MOUNTED PUMPS

60 to 4000 GPM
200 to 15000 L/min

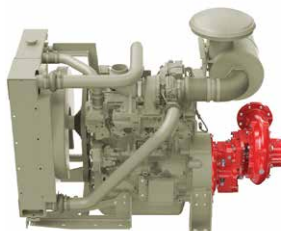

ADDITIONAL WATEROUS PRODUCTS

- FOAM SYSTEMS
- CAFSYSTEMS™
- MOTOR PUMPS

- ARFF PUMPS
- HIGH-RISE PUMPS
- SPECIAL APPLICATION PUMPS
- TRANSMISSION AND POWER TAKE-OFFS

THE ANATOMY OF A WELL-BUILT FIRE PUMP

CSU
Single Stage Pump

Flame Plating – A water pump is always at the mercy of its water supply. Sand and other debris in the water is the number one cause of water pump wear. That's why we designed our flame-plated impellers with particles of tungsten carbide. These particles create an ultra hard surface on the impeller that is more resistant to abrasion from debris. Our flame-plated impeller can last five times longer than a non-flame-plated impeller.

Wear Ring – A pump's wear rings ensure your pump maintains optimal performance. Since the 1970s, Waterous has manufactured labyrinth reverse flow wear rings. The labyrinth track helps reduce flow by forcing water to pivot before flowing back into the eye of the impeller. This prevents water from getting trapped in the pump, ultimately making the impeller more efficient.

Separable Impeller Shaft

– Downtime is detrimental to a fire apparatus. A pump containing a separable impeller shaft can help prevent unwanted downtime. If a problem arises, fire brigades can remove the shaft without disassembling the entire pump. This process can slash both downtime and maintenance costs.

Greater Than the Sum of its Parts

Waterous has the parts in stock and in-house. This means if you need a new part, it will get to you fast, usually within 24 hours. In addition, parts are available for a minimum of twenty (20) years from the date of manufacture of your fire pump or accessory.

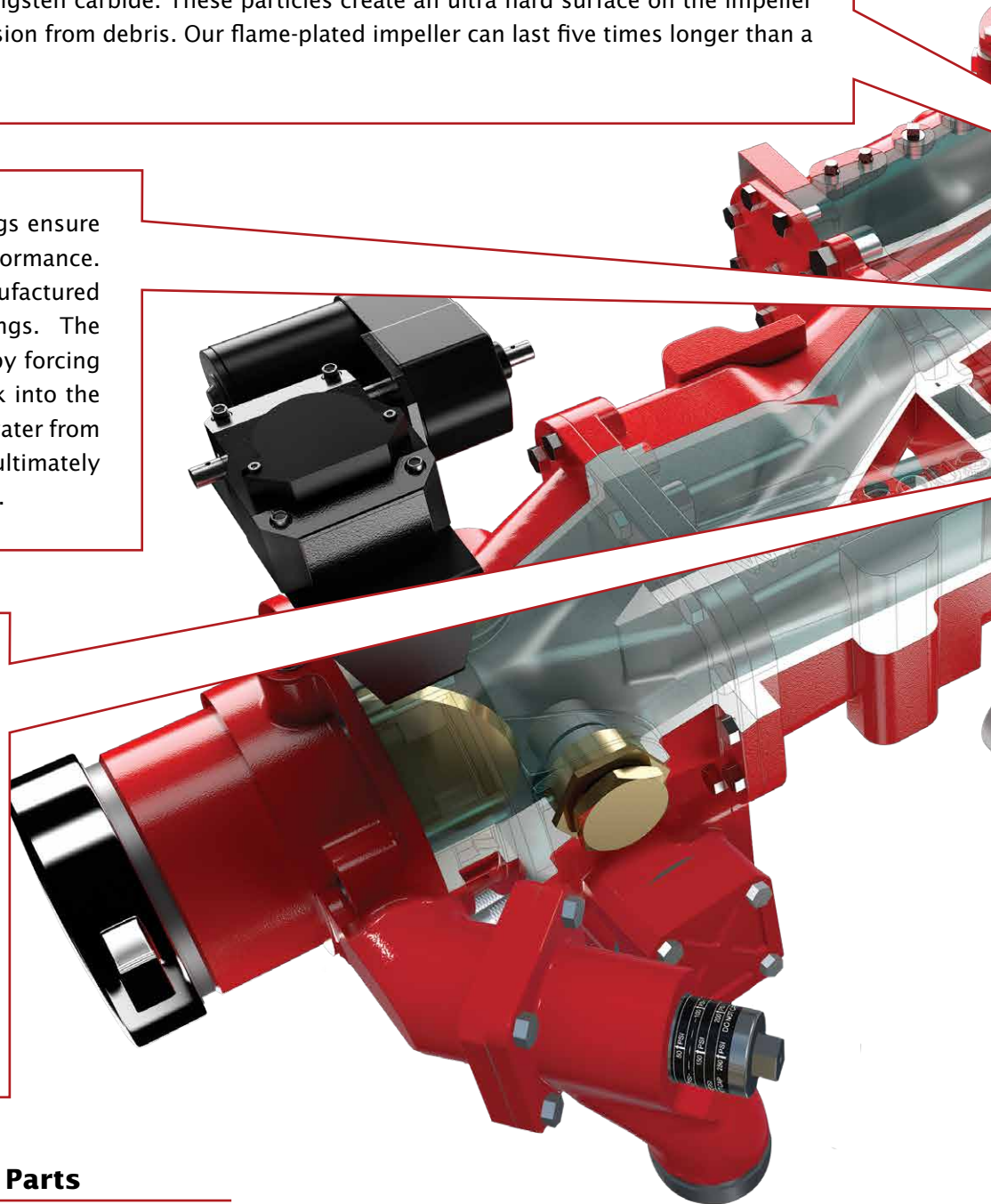

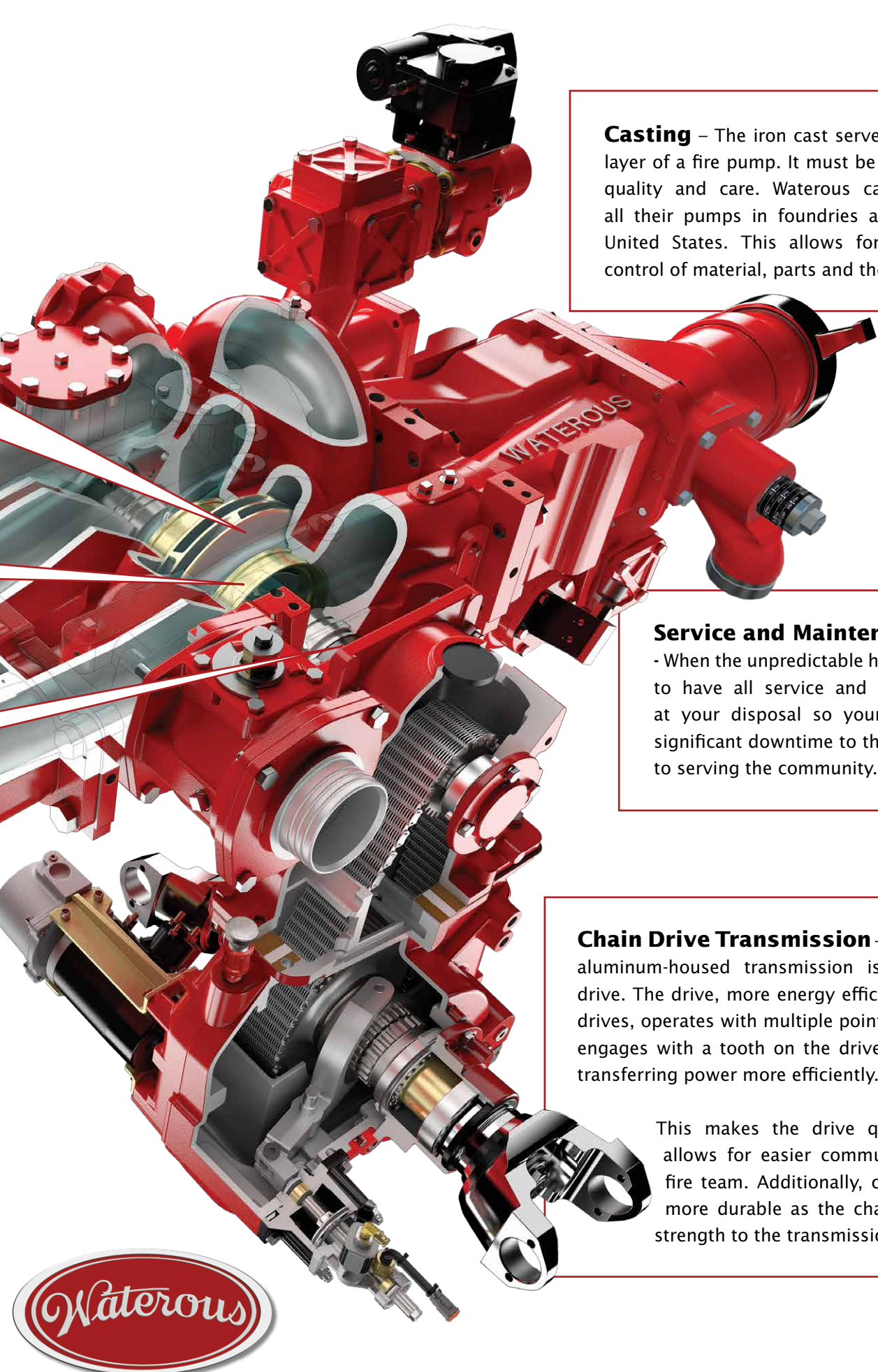

Casting – The iron cast serves as the outermost layer of a fire pump. It must be manufactured with quality and care. Waterous casts and machines all their pumps in foundries and facilities in the United States. This allows for increased quality control of material, parts and the overall pump.

Service and Maintenance

- When the unpredictable happens, it's important to have all service and maintenance options at your disposal so your fire teams can cut significant downtime to their fleet and get back to serving the community.

Chain Drive Transmission – Inside every Waterous aluminum-housed transmission is a multi-point chain drive. The drive, more energy efficient than conventional drives, operates with multiple points of contact. Each link engages with a tooth on the drive and driven sprocket, transferring power more efficiently.

This makes the drive quieter, which in turn allows for easier communication between the fire team. Additionally, chain-driven drives are more durable as the chain provides increased strength to the transmission.



WATEROUS KEY FEATURES

There is a lot that sets us apart from our competitors. From our best in industry parts warranty to our built-to-last flame-plated impellers, Waterous is the superior choice.



Scan the QR Codes for Videos about Waterous Features



FLAME-PLATED IMPELLERS

The heart of the fire pump is the impeller. Waterous impellers are vacuum cast bronze, hydraulically, and mechanically balanced for vibration-free operation. Waterous' available tungsten carbide flame plating adds up to 5x the life expectancy of the hub of the impeller.



CHAIN DRIVE TRANSMISSION

The C20 Transmission provides the best In-Class power transfer. The silent chain drive provides no gear whining, provides positive shifting and requires less horsepower that will enhance the efficiency of the apparatus.

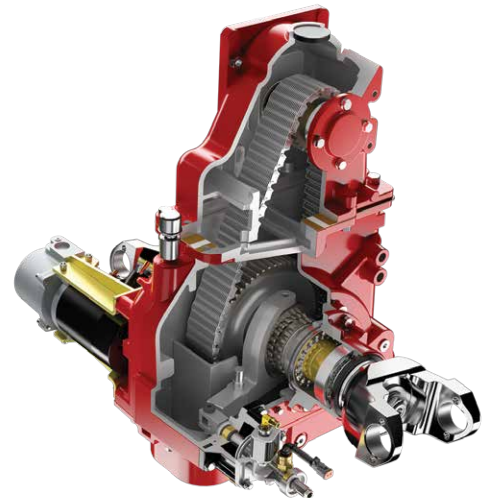

EASE OF MAINTENANCE

Separable Impeller Shaft

Allows you to remove the transmission while leaving the pump in the apparatus.

Preformed O-ring Gasket

Instead of paper gasket between pump body halves for better sealing and easier repair.

Sealed Outboard Bearings

Eliminates the maintenance at the outboard end of the pump.

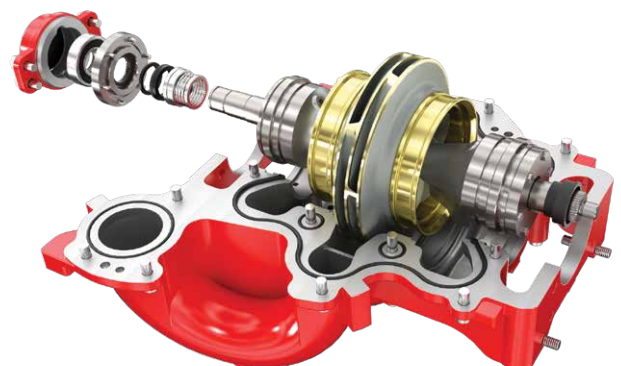



STANDARD 7-YEAR WARRANTY

Waterous's new standard, seven-year parts warranty is designed to bring customers added assurance alongside the most reliable fire pumps on the market. The new Waterous warranty is an additional two years in length, making it the longest warranty offered in the fire pump industry. The new warranty states that all pumps manufactured by Waterous will be free from defects in material and workmanship under normal use and service for a period of seven years from the date the product is first placed in service, or seven and a half years from the date of shipment.

For more information on the Waterous Warranty Scan Here:



WATEROUS WORRY-FREE PACKAGE

We face new challenges it seems on a daily basis. One challenge you shouldn't have to worry about is your fire pump. Ask for the Waterous Worry-Free Pump Package and receive assurances that your pump is protected by our 7-year parts warranty and, at no cost, our 5-year labor coverage (TPP-5). Additional components of the Worry-Free Pump Package protect not only your fire pump but protect the everyday heroes who put their lives on the line everyday. Contact your Waterous Sales Representative for more information.

For more information on the Waterous Worry Free Scan Here:



FREE APP CALCULATORS





SMOOTH NOZZLE DISCHARGE CALCULATOR	FRICTION LOSS CALCULATOR
NFA FIRE FLOW CALCULATOR	IOWA FIRE FLOW CALCULATOR





NO TUITION • NO TESTS • FREE ADMISSION

Waterous values the importance of continued knowledge in the field which is why we invested in Waterous University, a full library of support for the fire service.

waterousco.com/university

SUPERIOR CUSTOMER SERVICE



SETTING THE STANDARD FOR RELIABILITY SINCE 1886



CUSTOMER SERVICE

Scan here to learn more about why our customer service is outstanding.

When the alarm bell sounds, firefighters respond. That's their job. That's what people depend on. And that's exactly how Waterous feels about service. This mentality makes our service the best in the fire pump business. We're on call to answer your questions from product use to service maintenance. Service you can depend on. It's our promise. Our service staff ensures that over 95% of the parts orders received ship within two business days (ground shipments) and on the same day for rush orders. Our parts department maintains an order accuracy of 99% for all parts orders. We offer individual parts and repair kits. All Waterous pumps are tracked by serial number which ensures accurate pump records and parts orders.



MyWaterous is your easy to access portal for managing your Waterous pump. Through MyWaterous, you can access your quotes, orders, and invoices, as well as look up and order parts. To register for MyWaterous, visit waterousco.com.

Utilize MyWaterous For FREE to Find:

- **Parts and Manuals:** Enter a product serial number (manufactured since 2000) and get access to parts lists, installation, operation, maintenance and overhaul instructions. Place orders for replacement parts on-line.
- **Quotes:** Access to all active quotes for both complete products and repair parts.
- **Orders:** Access to all orders including order status, expected shipping date and shipment tracking information.
- **Invoices:** Ability to view and email all invoices, debit and credit memos.
- **Returned Material:** Access to the status of all material returned to Waterous including any credits issued.
- **Account Balance:** Check the current balance of your account including access to current and past-due invoices.
- **Resources:** Access to pre-2000 parts lists, operation, maintenance and overhaul instructions. Engineering documentation, technical bulletins, service tips, training material and more.

USA MADE SINCE 1886



At Waterous, we take pride in making products that are absolutely critical in helping firefighters protect life and property. That is why we think of the fire pump as the “heart” of the fire apparatus.

When spec'ing a new apparatus, don't overlook the most important part, the fire pump. And compare the differences. Waterous pump castings are from foundries in Ohio and Wisconsin, our impellers are vacuum cast in the USA, our impeller shafts, gears, drive sprockets are machined in our South St. Paul Factory along with pump bodies, transmissions and power take-offs.

We assemble, test and ship all our products from South St. Paul. We said earlier we take pride in our products and that is why we don't buy our castings from overseas, machine nearly all our components in-house and employ a workforce that is dedicated to providing the quality products you deserve.



Learn why Waterous Fire Pumps have been the Gold Standard for over a Century.



Supply chain issues are a problem in all industries. At Waterous, we minimize those problems by sourcing our castings and raw stock from foundries and companies inside the United States. We then machine castings and raw stock inside our South St. Paul factory so we are not waiting on the supply chain for our finished goods.

Waterous also maintains a large volume of repair parts in the event an apparatus goes out of service for needed repair.

While we can't promise that we may experience some supply chain issues in the future, we are less susceptible to those pressures by keeping our resources, machining and manufacturing inside the United States.



8 OF THE TOP 10 LARGEST CITIES CHOOSE WATEROUS

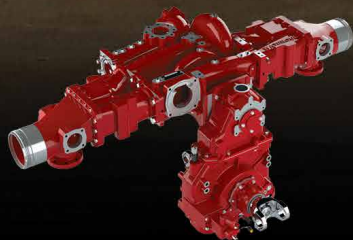

NEW YORK CITY • LOS ANGELES • HOUSTON
PHOENIX • PHILADELPHIA • SAN ANTONIO
DALLAS • SAN JOSE

Our nation's largest cities require the most demanding measure of durability and performance within the fire industry. No one knows that more than Waterous. It's why 80% of our largest cities trust Waterous as the force behind their fight.



waterousco.com