

PTO Compressor Kit Dimensional Drawings Model 80-P

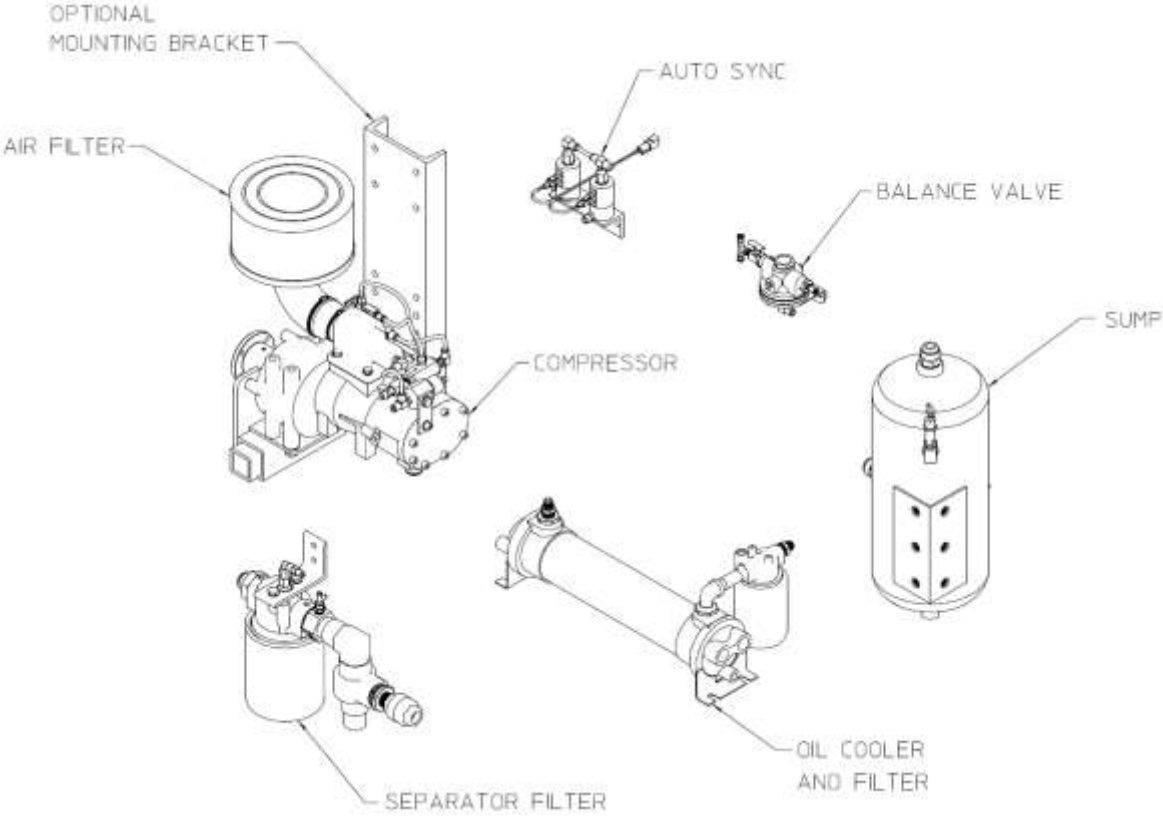

Standard Components:	Page
Compressor	2
Sump (Oil Reservoir)	3
Oil Cooler and Filter (Water Cooler)	4
Air Filter	5
Separator Filter	5
Oil Temperature Gauge	6
Auto-Sync	6
Balance Valve	6
Panel Plates	6
Optional Components:	
Air Distribution Manifold and Valves	7
Auxiliary Air Connection	8
Air Pressure Gauge	9
Digital Air Flow Meter	9
Sump Vent	9
Mounting Brackets	10
Air Oil Cooler (Electric Fan)	11
Oil Inject Check Valve	See DPL83810
Hose and Fitting Kit	See DPL83810
CAF Discharge:	
Air Discharge Check Valve Kits	See DPL83477
ICS Valves	See DPL83478
Static Mixers	See DPL83603
Manifolds	See DPL83682
Foam Pumps:	
Models Aquis 1.5, 3.0 or 6.0:	See F-1031-2447
Schematics:	
Hydraulic	12
Air Circuit	13
Electrical	14

ALL DIMENSIONS SHOWN AS INCH/MILLIMETER
 INCH
 (MILLIMETER)

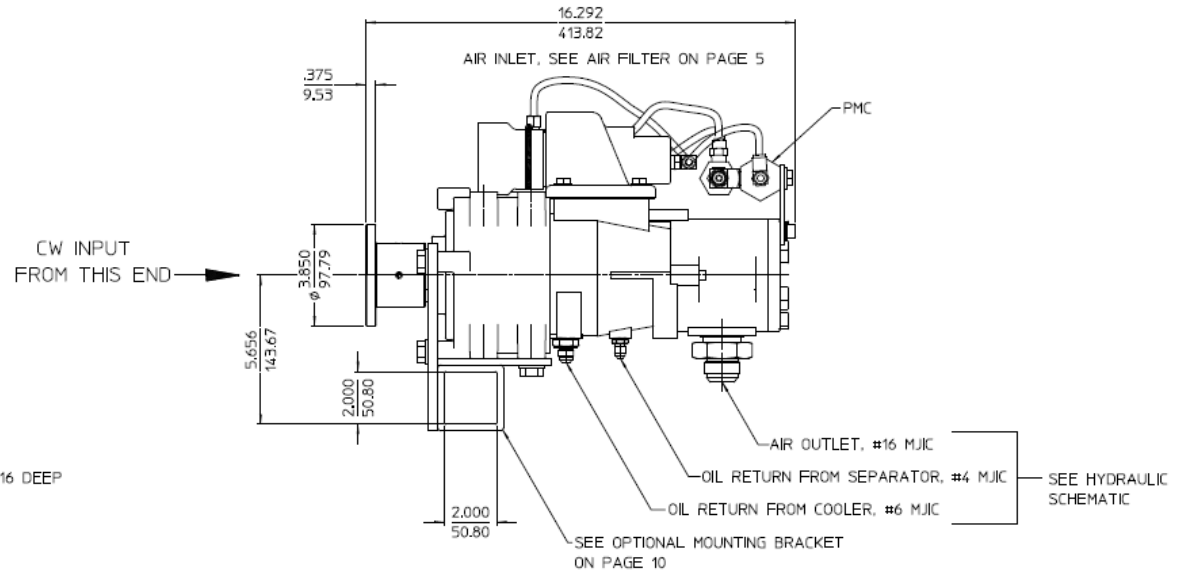
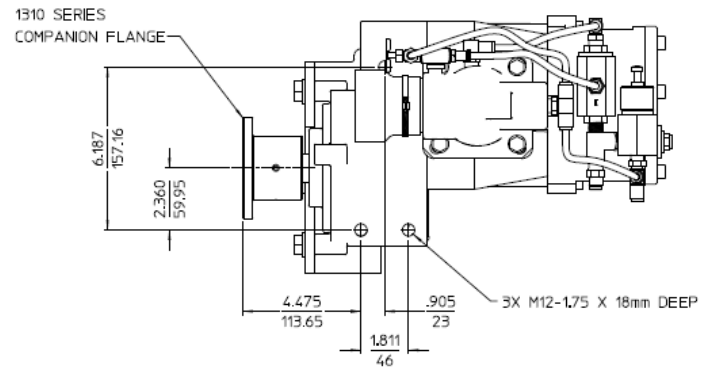
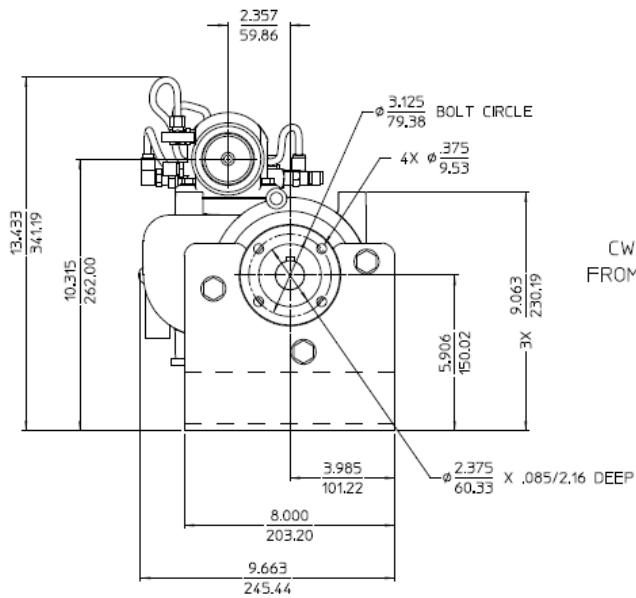

COMPRESSOR

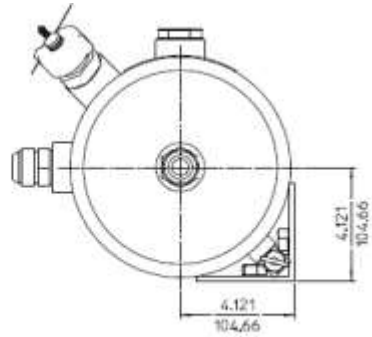

ALL DIMENSIONS SHOWN AS INCH/MILLIMETER
 (INCH / MILLIMETER)

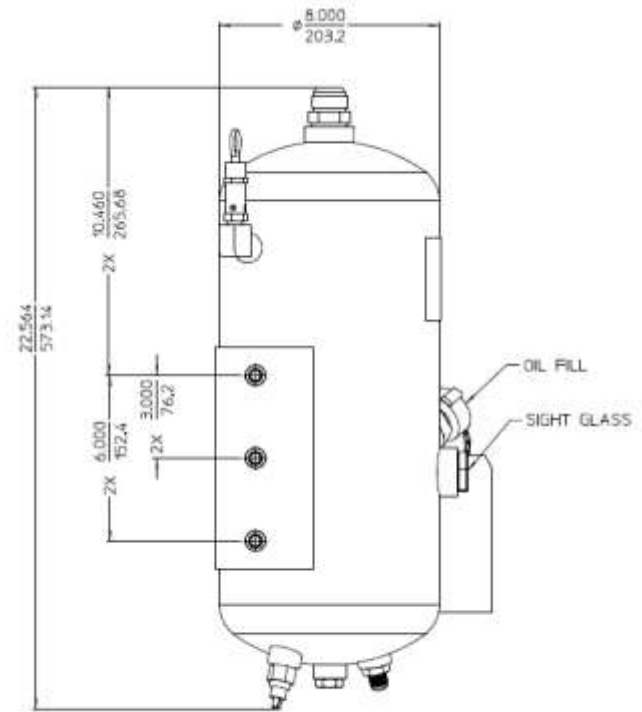
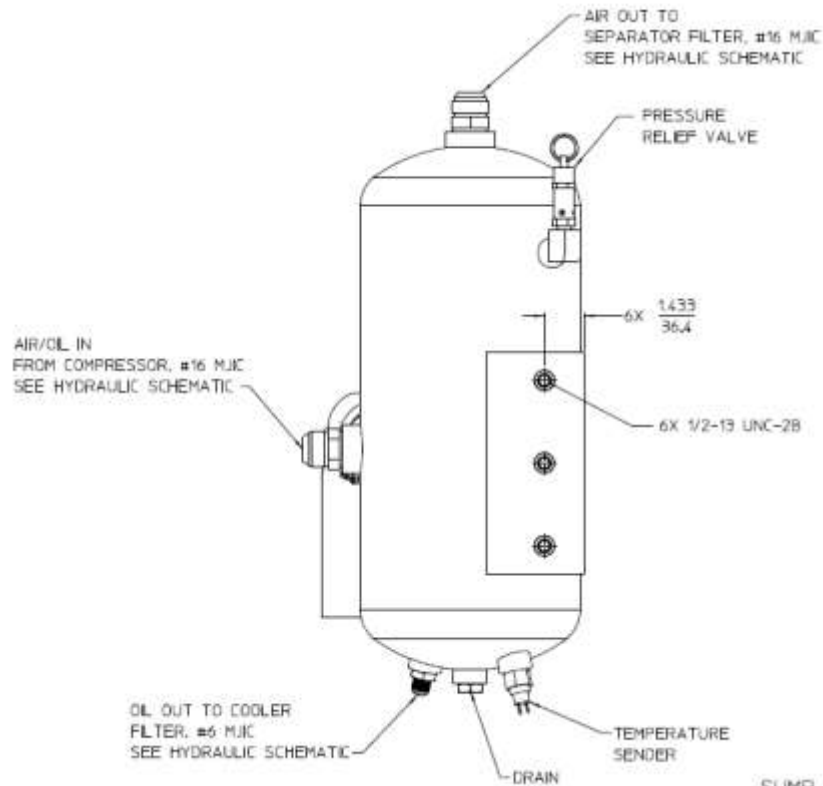

SUMP (OIL RESERVIOR)

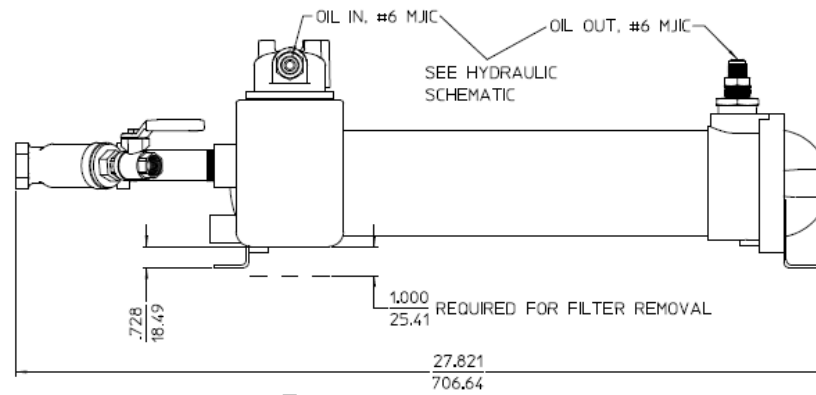
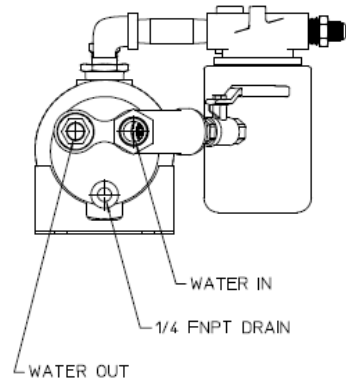
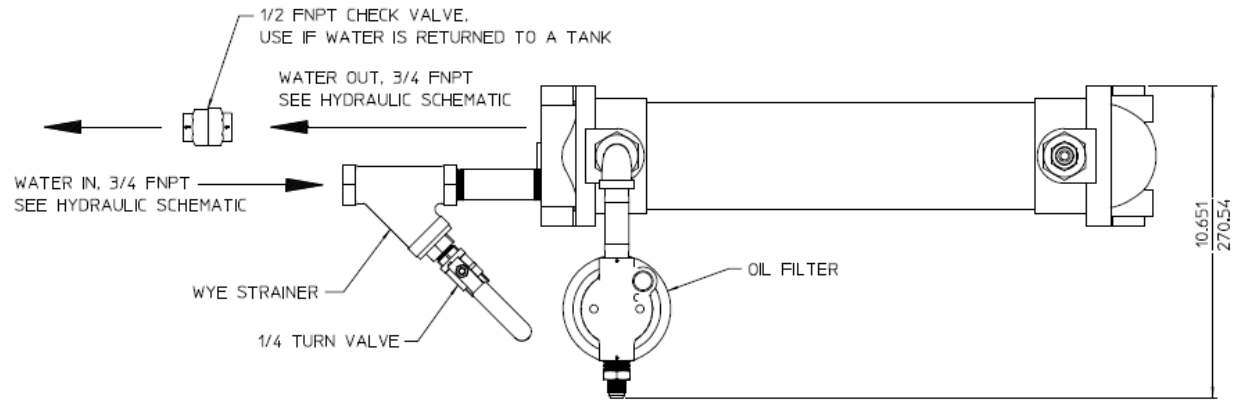

ALL DIMENSIONS SHOWN AS INCH/MILLIMETER
(INCH)
(MILLIMETER)

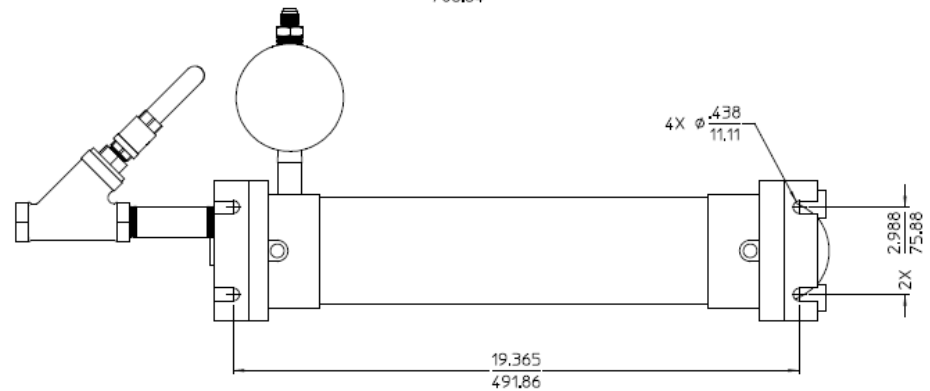

OIL COOLER AND FILTER

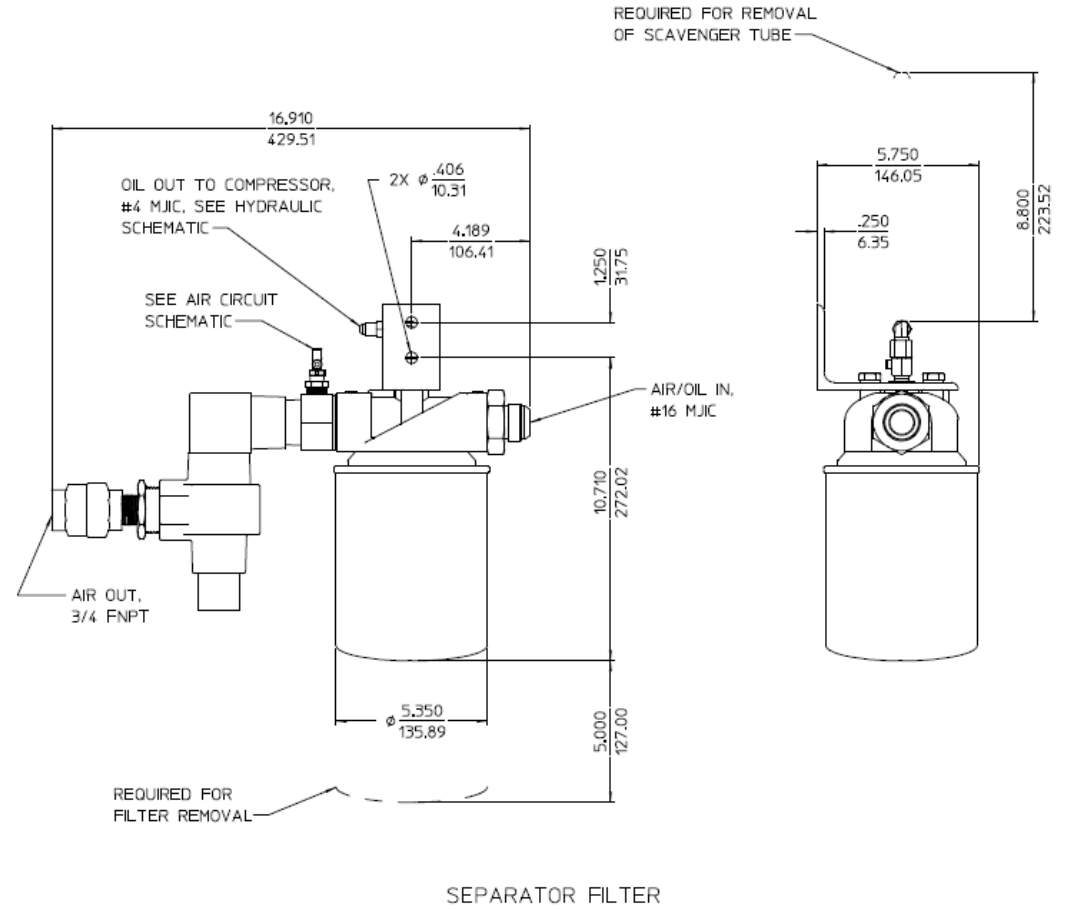
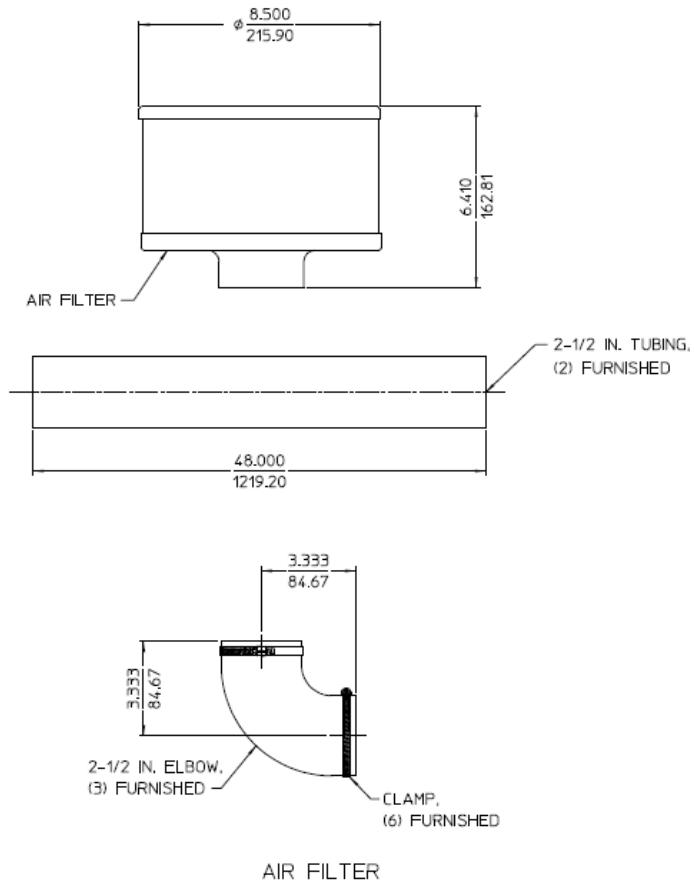

ALL DIMENSIONS SHOWN AS INCH/MILLIMETER
(INCH
MILLIMETER)

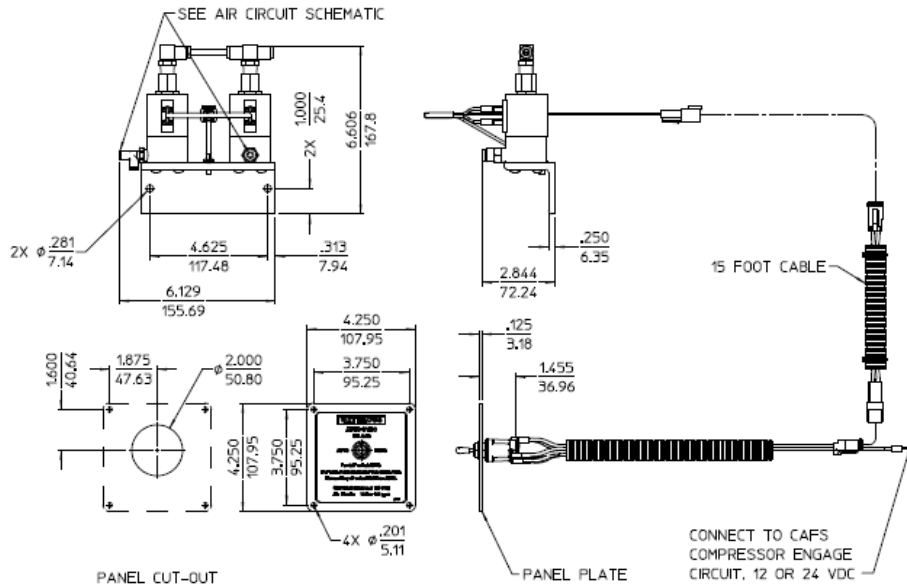

AUTO-SYNC

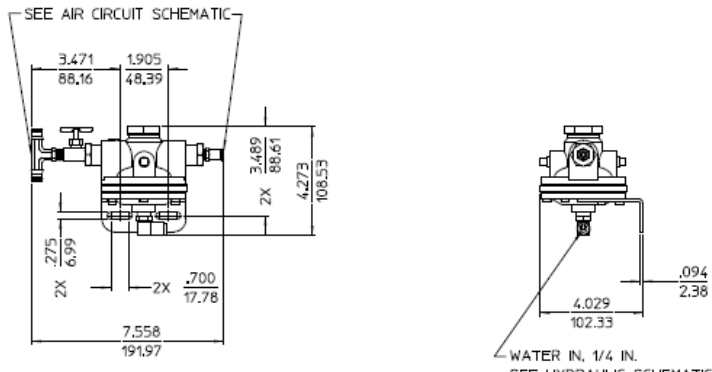

BALANCE VALVE

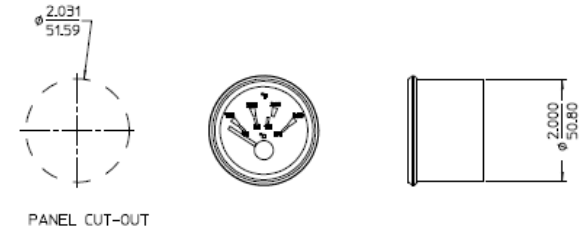

OIL TEMPERATURE GAUGE
(WIRING TO SUMP TEMPERATURE SENDER
NOT FURNISHED BY WATEROUS)

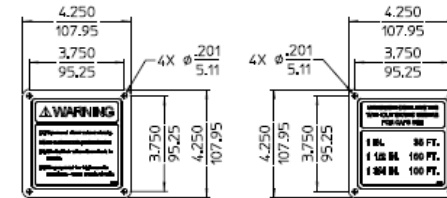

CAFS WARNING

HOSE LENGTH

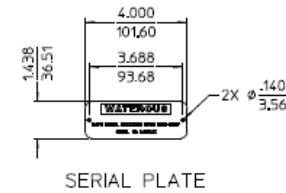

SERIAL PLATE

PANEL PLATES

ALL DIMENSIONS SHOWN AS INCH/MILLIMETER
(INCH)
(MILLIMETER)

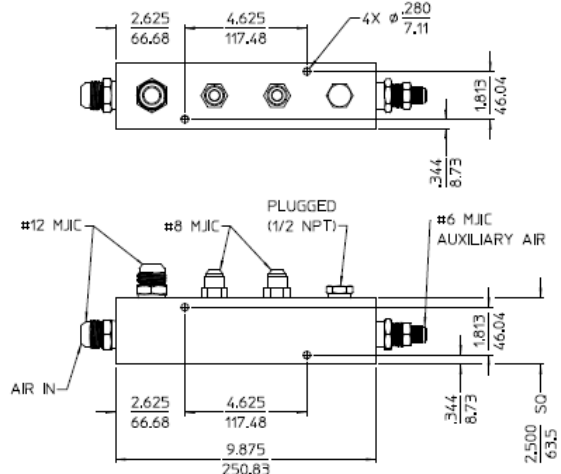

3 PORT MANIFOLD
ORDER PART NO. 83360-1A

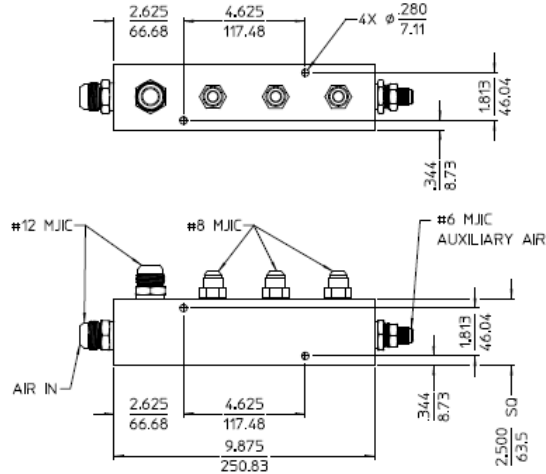

4 PORT MANIFOLD
ORDER PART NO. 83360-1B

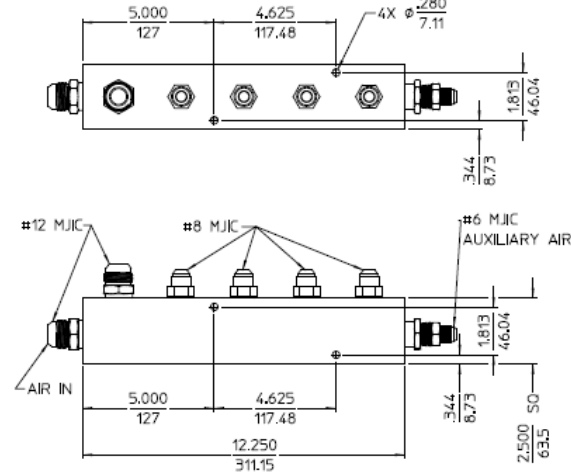

5 PORT MANIFOLD
ORDER PART NO. 83360-1C

OPTIONAL AIR DISTRIBUTION MANIFOLD

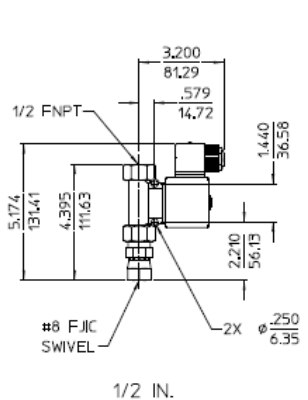

1/2 IN.

ELECTRIC

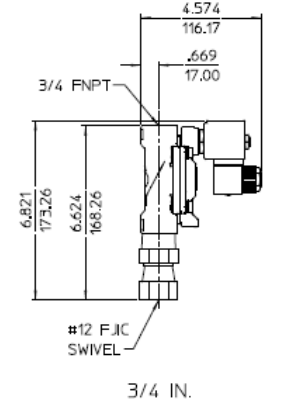

3/4 IN.

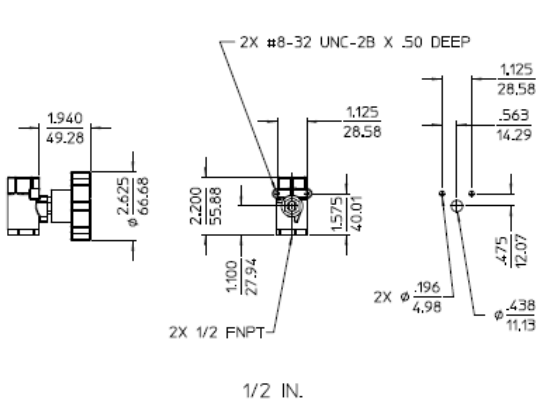

1/2 IN.

MANUAL

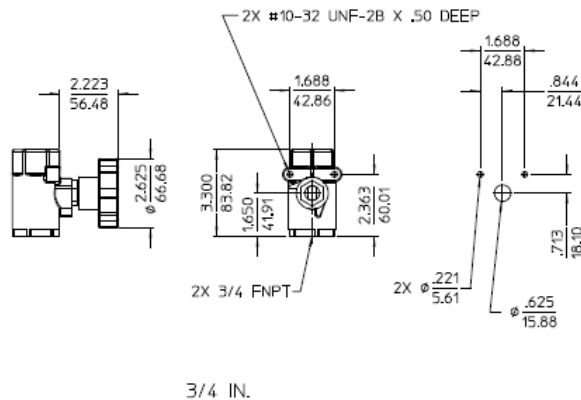

3/4 IN.

OPTIONAL AIR VALVES

ALL DIMENSIONS SHOWN AS INCH/MILLIMETER
(INCH / MILLIMETER)

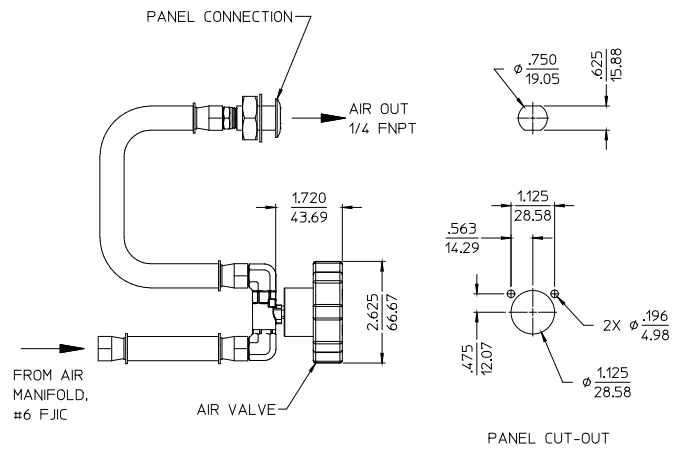
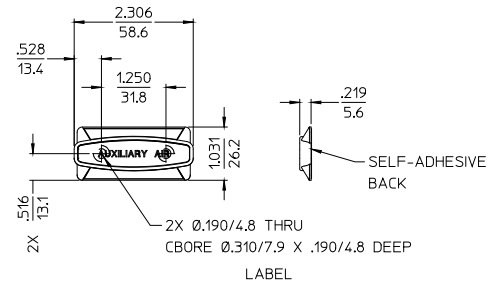
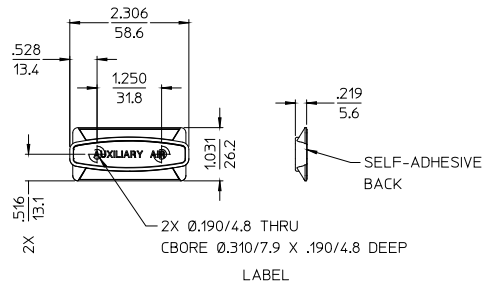

1/4 FNPT CONNECTION
(HOSES AND FITTINGS FURNISHED)
ORDER PART NO. 83360-3A

ALL DIMENSIONS SHOWN AS INCH/MILLIMETER
(INCH
MILLIMETER)

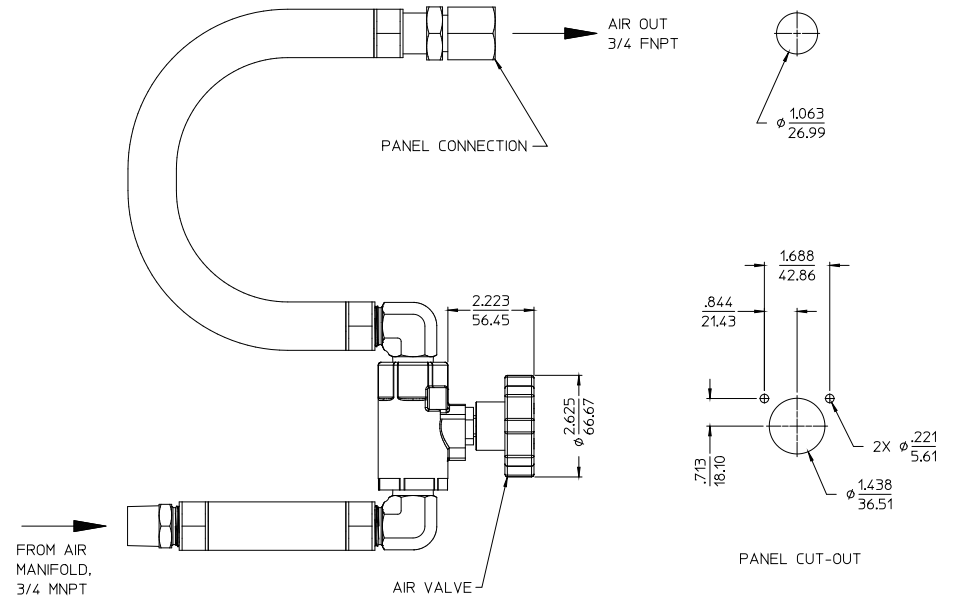

3/4 NPT CONNECTION
(HOSES AND FITTINGS FURNISHED)
ORDER PART NO. 83360-3B

OPTIONAL AUXILIARY CONNECTION



15 FEET OF BLACK TUBING FURNISHED!

OPTIONAL AIR PRESSURE GAUGE
SINGLE Mpa SCALE ORDER PART NO. 83417-1A
DUAL PSI/Kpa SCALE ORDER PART NO. 83417-1B

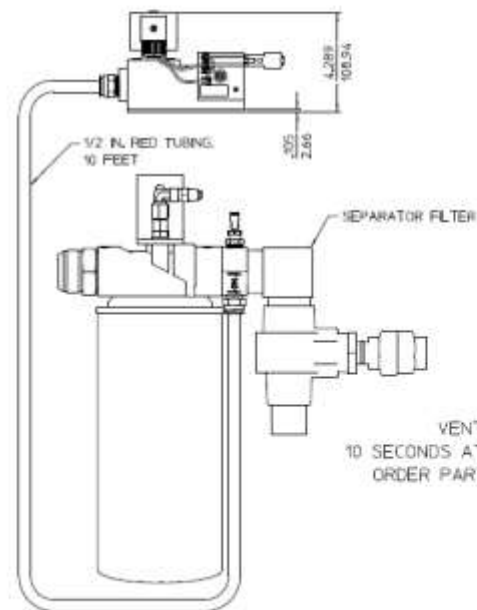
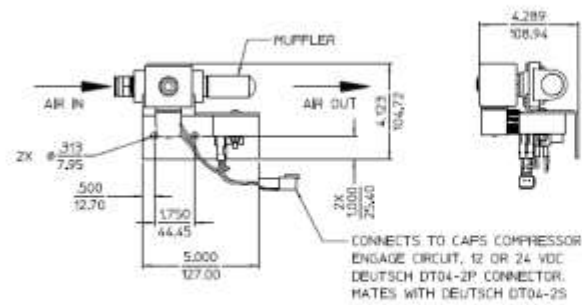
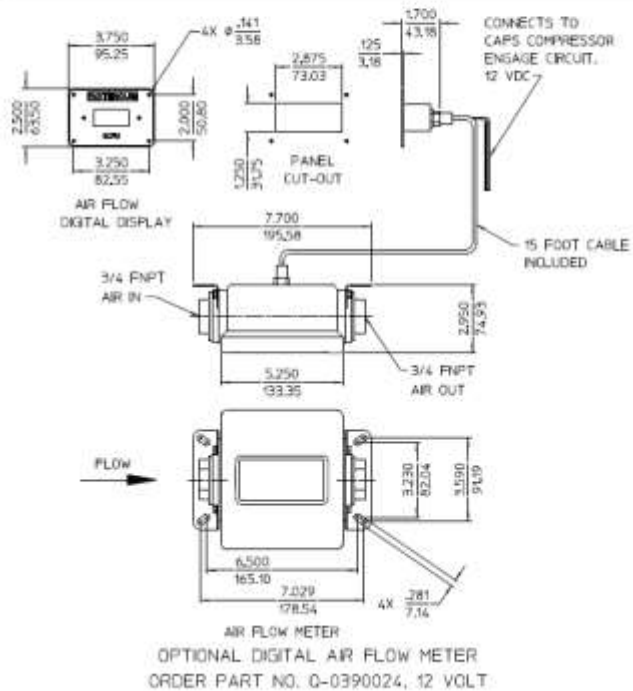

ALL DIMENSIONS SHOWN AS INCH/MILLIMETER
INCH
MILLIMETER

OPTIONAL SUMP VENT
VENTS COMPRESSOR PRESSURE FOR
10 SECONDS AT START-UP TO PREVENT ENGINE STALLING
ORDER PART NO. 83293-2A (12V) OR 83293-2B (24V)

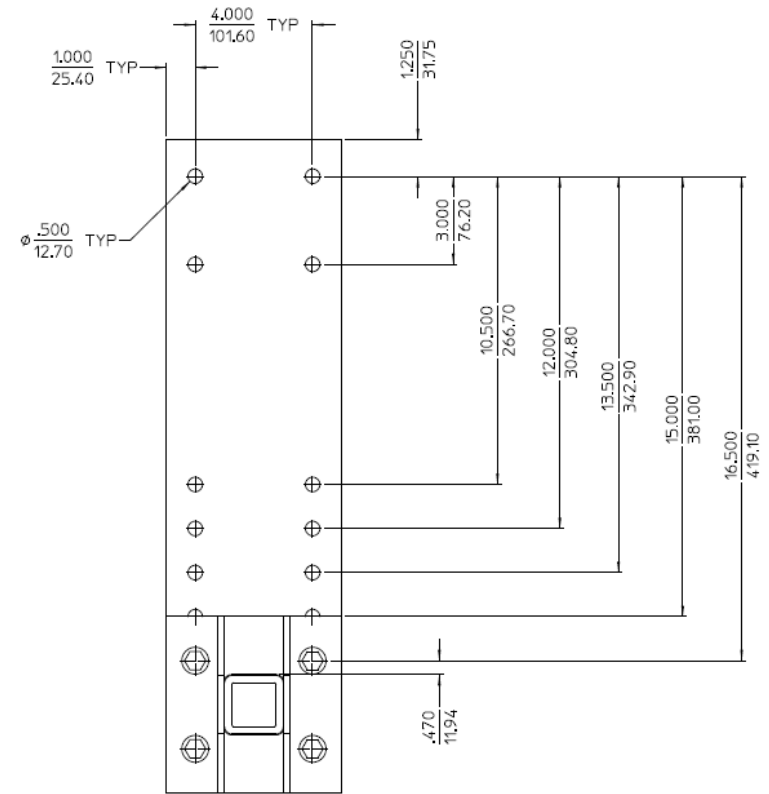
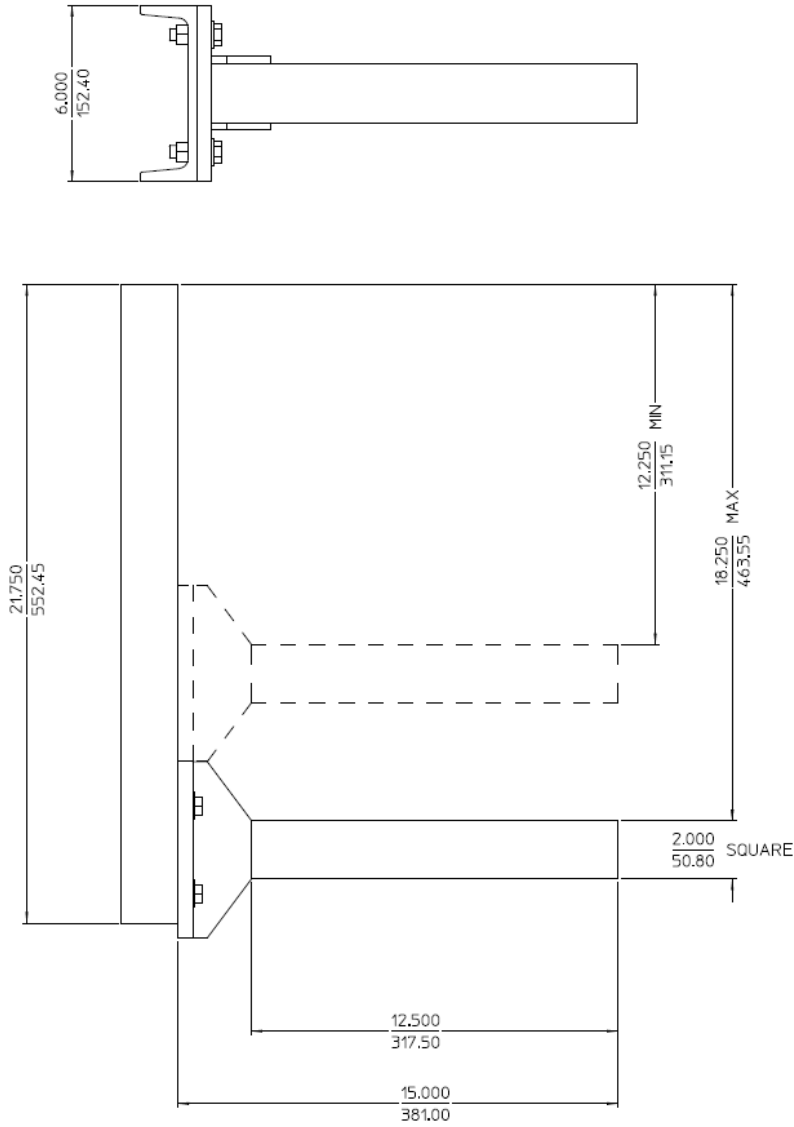

ALL DIMENSIONS SHOWN AS INCH/MILLIMETER
 (INCH)
 (MILLIMETER)

OPTIONAL MOUNTING BRACKETS

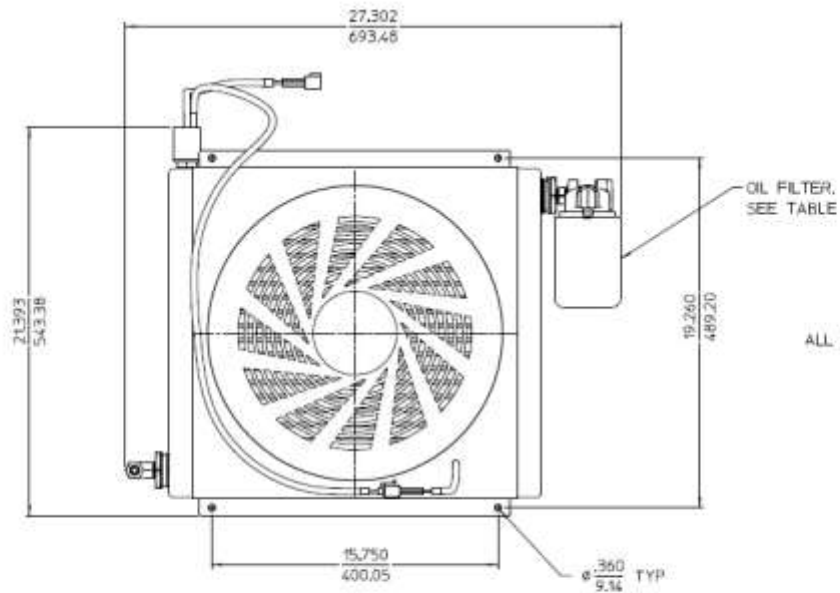
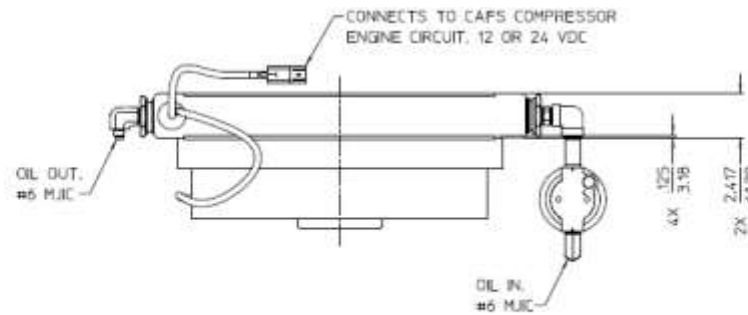

ALL DIMENSIONS SHOWN AS INCH/MILLIMETER
(INCH / MILLIMETER)

OPTIONAL AIR OIL COOLER
(ELECTRIC FAN)
AVAILABLE AS FOLLOWS:

USE	OIL FILTER
AS MAIN COOLER	INCLUDED
AS SECONDARY COOLER	NOT INCLUDED (INCLUDED WITH OIL COOLER, SEE PAGE 4)

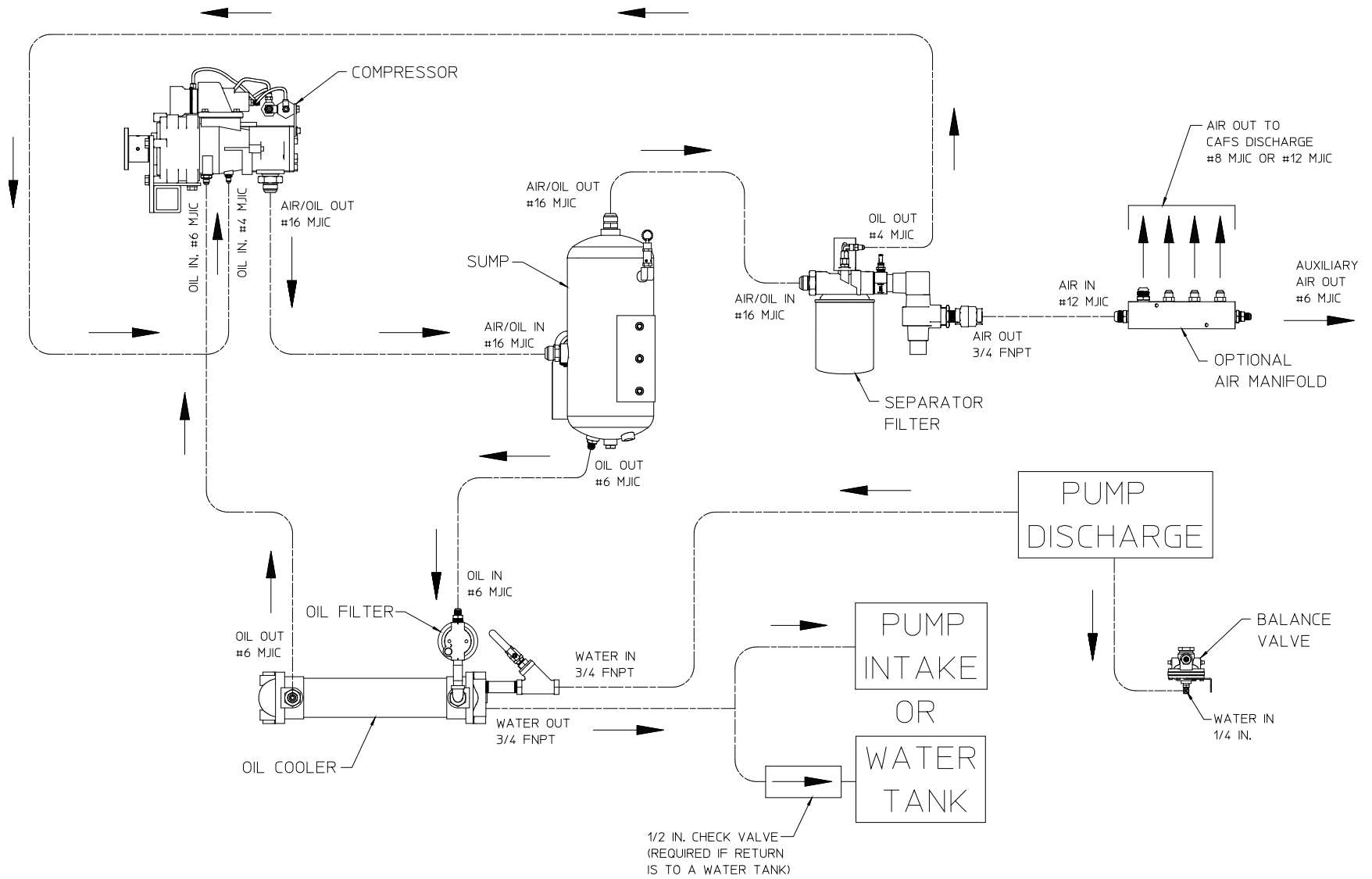

HYDRAULIC SCHEMATIC

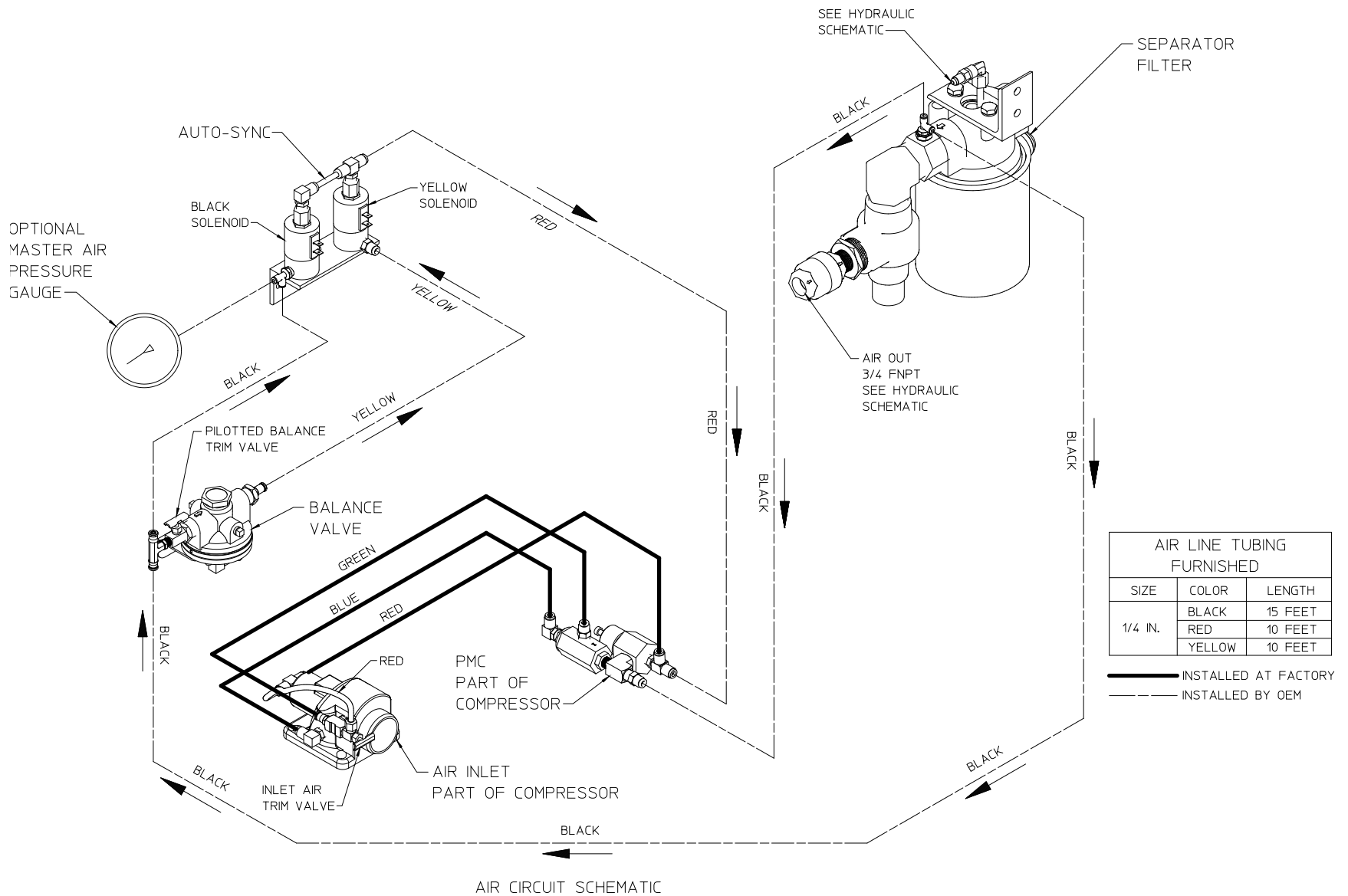

IGNITION SWITCH
POWER SOURCE +12 OR 24V

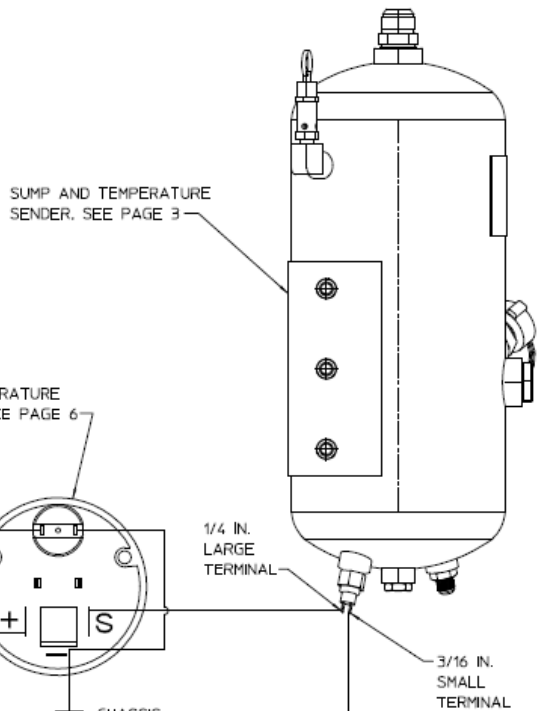

RESISTOR
24V ONLY

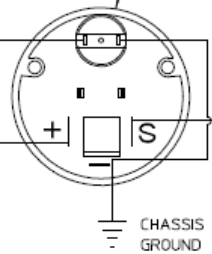

NOTE: WIRING AND LIGHT NOT
FURNISHED BY WATEROUS

NOTE: ALL WIRE 16 GAGE UNLESS NOTED OTHERWISE.

CAFS COMPRESSOR ENGAGE
POWER SOURCE +12 OR 24V

WIRING NOT IDENTIFIED BY
COLOR. SWITCHES AND LIGHTS
NOT FURNISHED BY WATEROUS

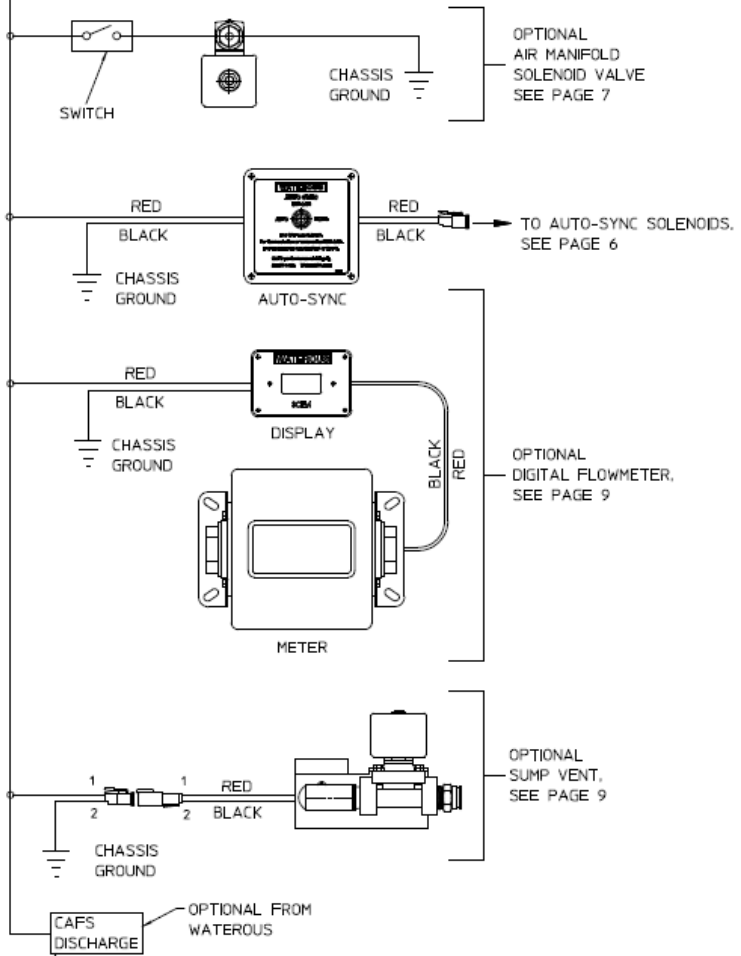

SEE THE FOLLOWING:
AIR DISCHARGE CHECK VALVE KITS: DPL83477
ICS VALVES: DPL83478

ELECTRICAL SCHEMATIC