

## Table of Contents



SECTION 1.	SAFETY, Everyone's Concern.....	3
SECTION 2.	INSTALLATION PLANNING .....	4
SECTION 3.	PLUMBING COMPONENTS .....	6
A.	Motor / Pump Assembly.....	6
I.	Power Supply.....	8
II.	Motor Driver / Controller.....	8
B.	Discharge Relief Valve.....	10
C.	Wye Strainer .....	10
D.	Flow Sensor .....	10
E.	Manifolds.....	10
F.	Injector .....	11
G.	Foam Check Valve.....	11
H.	Drain Lines .....	11
I.	Flushing System .....	12
J.	Inject / Bypass Valve.....	12
SECTION 4.	ELECTRICAL COMPONETS .....	13
A.	Operator Interface Terminal (OIT) .....	14
B.	Conductivity Probes .....	15
C.	Flow Sensor .....	16
D.	Cables and Ground.....	16
SECTION 5.	CALIBRATION AND SETUP .....	17
A.	Entering Calibration Mode .....	17
B.	F1 - Default Mix Percentage .....	<b>Error! Bookmark not defined.</b>
C.	F2 – Units of Measurement.....	<b>Error! Bookmark not defined.</b>
D.	F3 – Flow Rate Calibration .....	<b>Error! Bookmark not defined.</b>
E.	F4 –System Lockout ..	<b>Error! Bookmark not defined.</b>
F.	F5 – Foam Select.....	<b>Error! Bookmark not defined.</b>
G.	F6 – Simulated Water Flow (per NFPA testing)	<b>Error! Bookmark not defined.</b>
H.	F7 - Default Mix Percentage B foam	<b>Error! Bookmark not defined.</b>
I.	Saving Calibration .....	19
SECTION 6.	OPERATION .....	20
A.	Operating the System .....	20
SECTION 7.	TROUBLESHOOTING CHART .....	25
SECTION 8.	DRAWINGS .....	27
SECTION 9.	ILLUSTRATED PARTS LIST .....	32
SECTION 10.	PART LIST .....	34
SECTION 11.	CONDITIONAL 2-YEAR WARRANTY POLICY	<b>Error! Bookmark not defined.</b>



Read through the installation instructions carefully.

NOTE: Instructions subject to change without notice.

## Warnings, Cautions, and Notes

---

**Warning:** A warning alerts you to a procedure, practice or condition that may result in death or long term injury to personnel or destruction of equipment.

---



---

**Caution:** A caution alerts you to a procedure or condition that may result in serious damage to equipment or its failure to operate as expected

---

**Note:** A note points out important information. Failure to read the note may not result in physical harm to personnel or equipment. It may waste time and money.

### ATTENTION:

Defects in replacement part(s), component(s) or product(s) manufactured by others and furnished by WATEROUS is understood that the only warranty provided for such replacement part(s), component(s) or product(s), shall be the warranty provided by the manufacturer of said replacement part(s), component(s) or product thereof which, if assignable, WATEROUS will assign to Buyer, if requested by Buyer.

Defects in replacement part(s), component(s) or product(s), not furnished by Waterous, but suggested in the installation guide, are the responsibility of the installer and the manufacturer of said replacement part(s), component(s) or product(s). Waterous will not be responsible for any replacement part(s), component(s) or product(s) that are not furnished or purchased from Waterous.

### Revision History

Revision	Date Issued	Comments
-	05/03/07	Initial Release
1	11/131/08	New Motor Driver / Controller pics, new PNs, added Cond. Probe w/ temp sensor, corrected fig 16 parts list, added Manual mode chart, chg term strip pic, added foam pump warning, Flow sensor # chg
2	5/27/09 10/14/09	Added F5, F6 to the Calibration section & priming mode (in operations), updated fig 5 & fig 6 Updated pics and drawings
3	3/5/10	Added F7 and foam caution
4	7/19/10	Added Certificate
5	1/7/11	Added troubleshooting chart
6	8/4/11	Changed terminal block drawing, added USB pic, updated motor driver pic

**Disclaimer:** These instructions are guidelines only and in no way meant to be definitive. During installation, standard safety precautions and equipment should be used where appropriate. Because the tools used and the skill/experience of the installer can vary widely, it is impossible to anticipate all conditions under which this installation is made, or to provide cautions for all possible hazards. Proper installation is the responsibility of the purchaser. All bolts, setscrews, and belts must be checked prior to start-up AND after the initial operation. Damages due to poor installation are the responsibility of the installer.

Waterous reserves the right to make modifications to the system without notice

## SECTION 1. SAFETY, Everyone's Concern

Please read all of the following safety precautions and follow carefully. They are important to the prevention of personal injury or damage to the equipment.

1. Do not pump at pressures higher than the maximum recommended pressure. [400 psi (28 BAR)]
2. Do not permanently remove or alter any guarding devices or attempt to operate the system when these guards are temporarily removed.
3. Always disconnect the power source before attempting to service any part of the pump.
4. Release all pressure within the system before servicing any of its components.
5. Drain all concentrate and water from the discharge system before servicing any of its component parts.
6. Check all hoses for weak or worn conditions on a regular basis. Ensure that all connections and fittings are tight and secure.
7. Use only pipe, hose, and fittings from the foam pump outlet to the injector fitting, which are rated at or above the maximum pressure [400 psi (28 BAR) minimum] rating at which the water pump system operates.
8. Any electrical system has the potential to cause sparks during service. Take care to eliminate explosive or hazardous environments during service/repair.

---

**Caution:** Do not attempt to operate the system at or above a temperature of 160°F (71°C)

Ensure that the electrical source of power for the unit is the appropriate 12 or 24 volt, negative ground DC system, with a minimum current rating of at least 80 amps for 12 VDC or 50 amps for 24 VDC System.

Periodically inspect the pump and the system components. Perform routine preventive maintenance as required. Failure to perform routine maintenance may cause damage to the pump.

Read and understand "Operation" section before attempting to operate the unit.

Always disconnect the ground straps and control cables from the control module or other Advantus equipment before electric arc welding at any point on the apparatus. Failure to do so will result in a power surge through the unit that could cause irreparable damage to the system components.

The cables shipped with each Advantus unit are tested at the factory. Improper handling and forcing connections can damage these cables which could result in other system damage.

---

This document explains how to set up and operate the Advantus Foam Control system.

## SECTION 2. INSTALLATION PLANNING

The Waterous recommends that you spend time planning where and how you intend to install this unit in the equipment before beginning the actual installation.

Determine the locations of the components to be installed such as; foam tank, Motor / Pump Assembly, Manifold and OIT.

- Locate the pump as close to the supply source as possible. Install it in a clean space where it will be easy to inspect and maintain. Allow room for checking the oil level, changing the oil, and general servicing.
- Try to place components in locations that require the least amount of cables, hoses and fittings.
- Position the Motor / Pump Assembly in an area that is protected from road debris and excessive heat buildup.
- It is recommended that the Motor / Pump Assembly be installed in an accessible compartment located in the vicinity of the Operator Interface Terminal (OIT) panel.
- Place the foam tank so that the refilling can be done safely.
- Most water tank manufacturers will build the foam tank into the booster tank.
- When specifying a integral foam tank, make sure provisions are made for installation of the optional low tank level sensor as well as foam suction connections and tank drainage according to NFPA.

Determine a location for the Operator Interface Terminal (OIT) on the operator panel of the equipment.

- Consider the routing path of the cable from the Operator Interface Terminal (OIT) to the Pump / Motor Driver Assembly.
- If necessary, order longer or shorter cable assemblies to suit the location demands.

**Note:** Cables can be daisy chained to obtain longer lengths.

---

---

**Warning:** Never attempt to cut or lengthen the molded cables.

Always disconnect the ground straps and control cables from the Operator Interface Terminal (OIT) or other Advantus equipment before electric arc welding at any point on the apparatus. Failure to do so could result in a power surge through the unit that could cause irreparable damage to the electronic components.

---

---

---

**Caution:**      **Ensure Adequate Concentrate Supply.**  
Advantus 3 - a minimum of ¾ inch ID tubing  
Advantus 6 - a minimum of 1 inch ID tubing

**Safety Guards.**  
Follow all codes and regulations regarding installation and operation of the Advantus system.

**Shut-Off Valves.**  
Never install shut-off valves between the pump and discharge pressure regulator, or in the regulator bypass line.

---

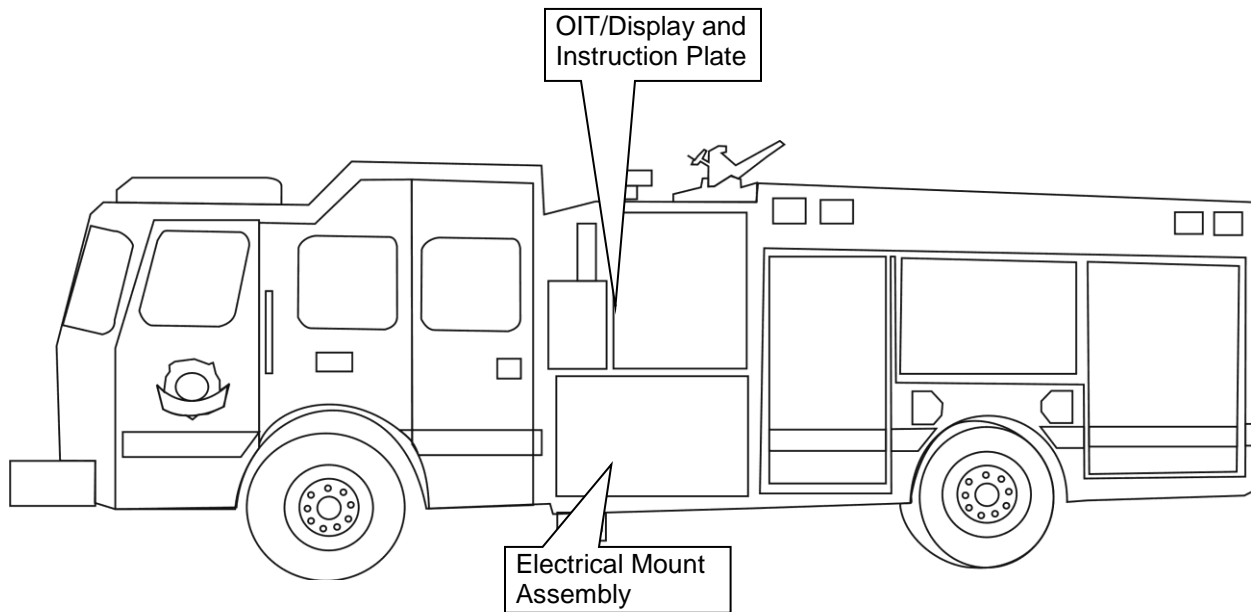

## SECTION 3. PLUMBING COMPONENTS

### A. Motor / Pump Assembly

The Motor / Pump Assembly must be mounted horizontally. The base must be anchored to a surface or structure that is rigid and of adequate strength to withstand the vibration and stresses of apparatus operation.

The mounting plate, Figure 13, provides the mounting dimensions for the Motor / Pump Assembly. Flexible hose is required to make the hose connections from the Motor / Pump Assembly to the foam tank.

DO NOT hard pipe the system.

Consider access requirements for checking the foam pump. Be sure the foam concentrate hoses can be properly routed to the inlets and outlets on the foam pump.

Foam concentrates should gravity feed to the foam pump inlet from the foam tank. However the systems are capable of drafting up to 1 meter vertically. The Motor / Pump Assembly must be mounted in an area to avoid excessive exhaust system heat buildup.

Protect the hoses and wiring to prevent chafing and abrasion during operation of the foam system.

Protect the Motor / Pump Assembly from excessive road spray and debris. Although the system is sealed and designed to be resistant to the harsh environment of fire fighting apparatus, a protected compartment with easy operator access is the recommended installation location.

---

**Warning:** DO NOT run system with foam shutoff valve in the OFF position. Damage to foam pump will occur.

---



**Figure 1 Advantus 6 GPM SSP mounting**

The large circuit breaker (See Figure 2) is used to connect the 12 VDC input power.

Make sure you provide adequate electrical power (80 amps minimum for 12 VDC or 50 amps for 24 VDC) from the battery. Use 8 AWG (minimum) wire directly to the battery or battery switch. Long wire runs may require 6 or 4 AWG wire for proper operation.

Recommended wire sizes	
Wire Size	Wire Length (approx.)
8 awg	Less than 10 feet
6 awg	10 feet to 20 feet
4 awg	20 feet or more

## I. Power Supply

Electrical devices can be easily damaged by a weak or erratic power supply. The better the power supply, the better the Advantus system will perform. At maximum output, the Advantus system can draw 80 amps at 12 VDC or 50 amps at 24 VDC.

Connect the ground lead from the chassis frame or the negative battery terminal. Use the same size wire as the power lead.

DO NOT connect the main power leads to small leads that are supplying some other device such as a light bar or siren.

---

**CAUTION:** Be careful not to damage or short circuit the wires leading to the circuit breaker. Only the Advantus system is protected by the circuit breaker..

---

## II. Motor Driver / Controller

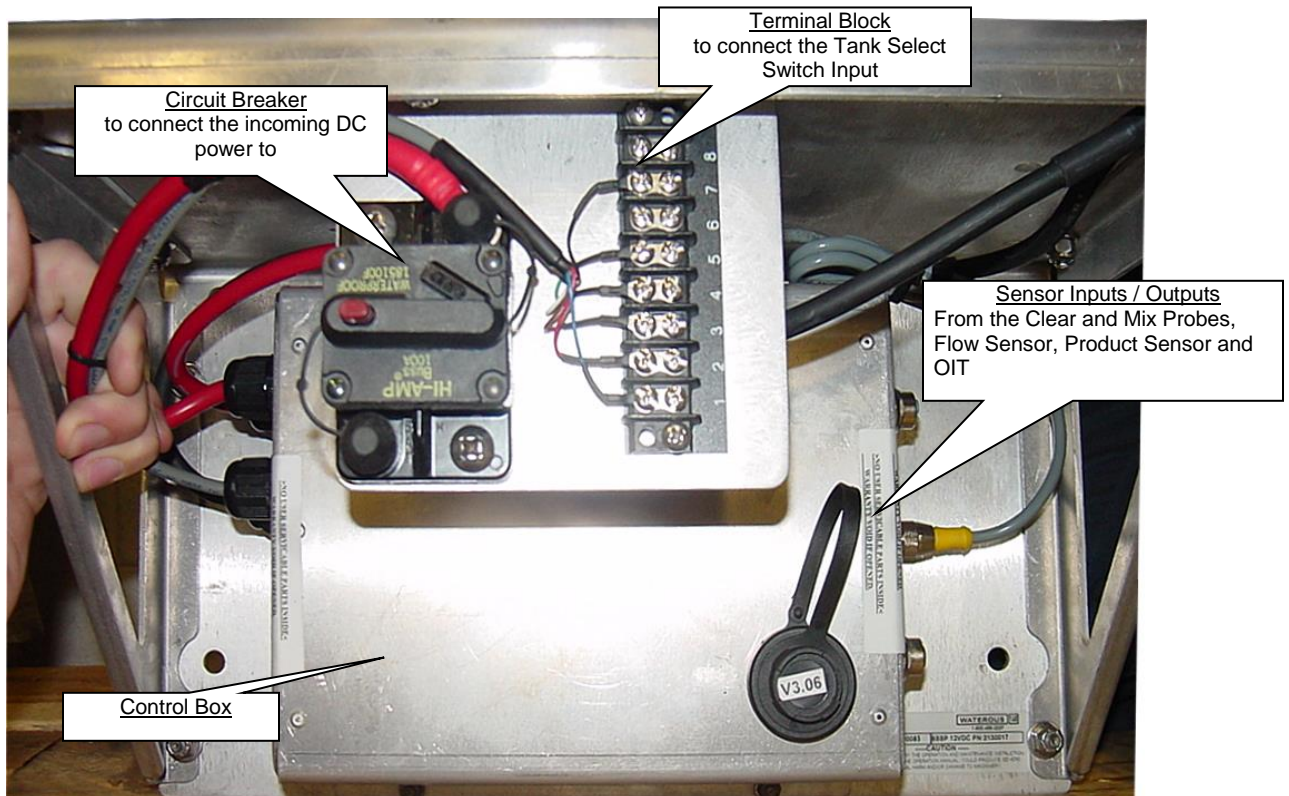
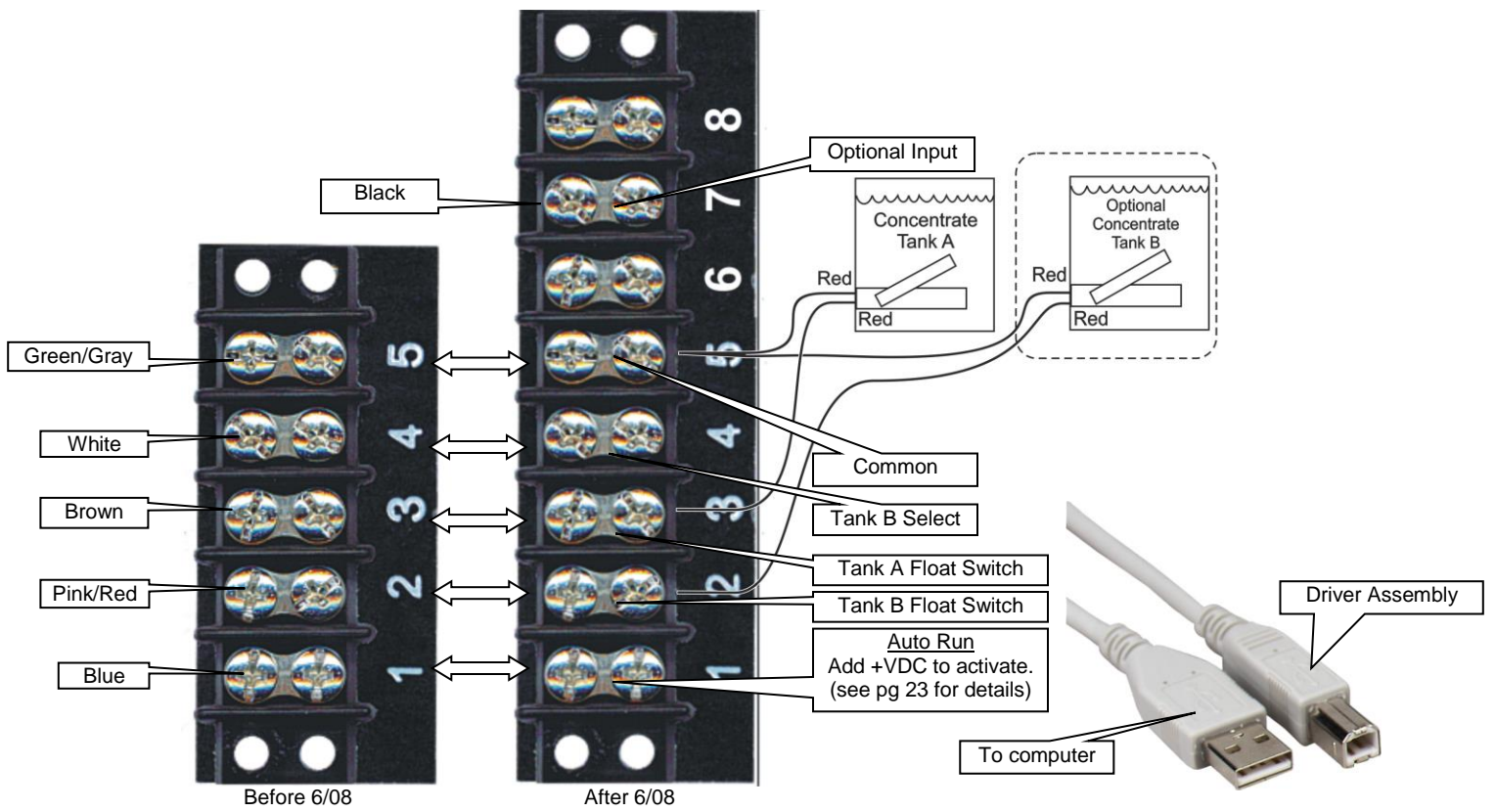

Figure 2 Terminal block location (after 6/08)

There are no user serviceable parts inside the Control Box. All power and ground cables will come with the new box





**Figure 3 Terminal Block / Foam Tank Schematic**

**USB connections**

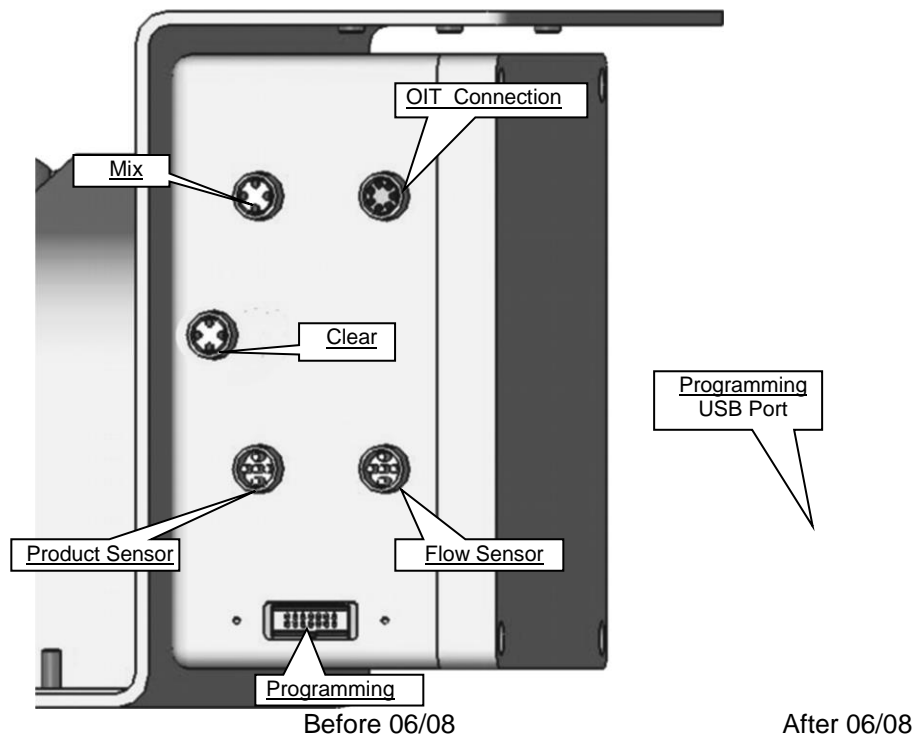

**Figure 4 Motor Driver Assembly - Cable connectors**

## B. Discharge Relief Valve

The discharge relief valve is installed on the outlet port of the foam concentrate pump. It is provided to protect the pump from excessive pressures. The relief valve is factory set at 450 psi [31 BAR].

## C. Wye Strainer

The line strainer provided with the unit has 1 inch NPT female threaded ports will need to be installed, in-line, between the foam supply tank and the foam pump. The hose from the foam tank should have adequate wall stiffness to withstand the vacuum of the foam pump while it is operating.

**NOTE:** If a pressurized water flush from one of the discharges is incorporated, the plumbing and line strainer exposed to this pressure must be rated at or above the operating pressure of all other discharge plumbing components.

## D. Flow Sensor

The flow sensor measures the water flow through the foam manifold system and sends the information to the Control Box and OIT Display. (Figure 8)

## E. Manifolds

Advantus 6 SSP is supplied completely assembled, but orientation can vary. Manifold 1, which is used after the injection, and Manifold 2, which is used before foam injection.

The Manifold includes 2 conductivity probes, Mix (Blue) and incoming water conductivity probe, Black, a paddlewheel flow sensor, foam injector with a check valve, and an Akron Brass waterway check valve.

In horizontal runs, the mix side of the manifold w/ probes should be mounted upright.

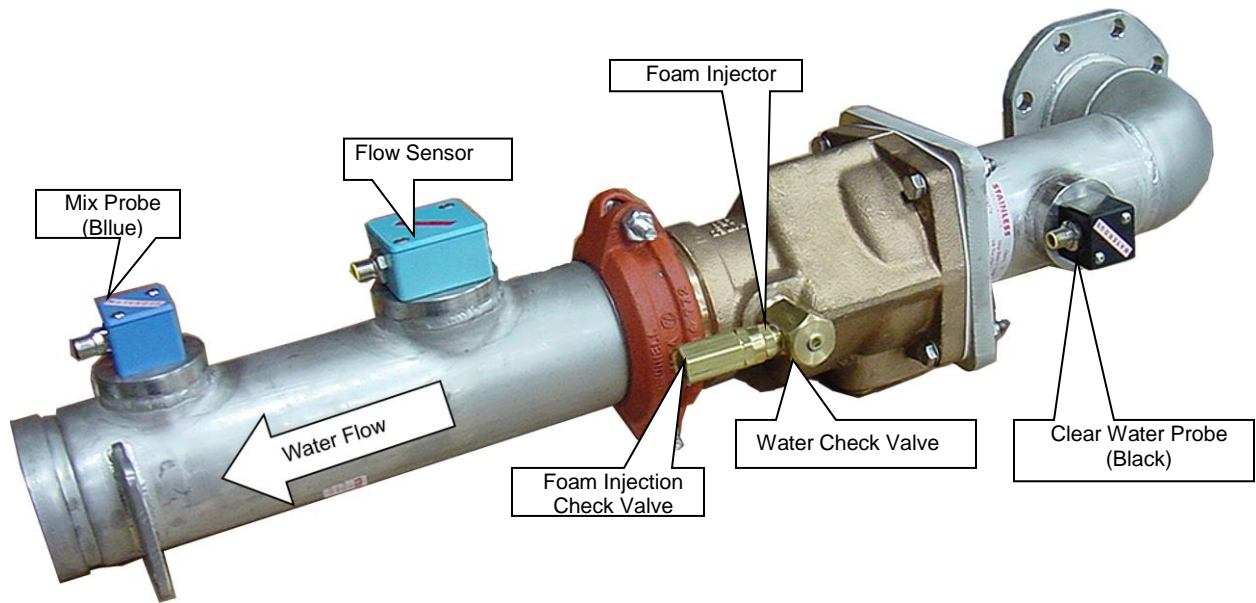

**Figure 5 Manifold**

Right Hand Orientation

## F. Injector

The brass injector fitting ensures the foam concentrate is injected into the center of the water flow for better mixing.

## G. Foam Check Valve

A 3/8 inch check valve meets NFPA requirements for a non-return device in the foam injection system.

**DO NOT OVER TIGHTEN.**

The check valve in the water way is required to keep foam solution out of the main pump and allow pump priming without drawing foam into the piping.

## H. Drain Lines

On apparatus with multiple drain lines, the drains from the foam solution discharge line should not be piped into a multi drain system before the check valves. The standard multi drain system from most manufacturers will allow cross talk between the drain lines and the apparatus water tank, resulting in contamination of the water tank with foam. A separate drain system should be provided for foam solution piping to prevent contamination of the water tank and fire pump.

## I. Flushing System

Depending on the corrosiveness of the foam concentrates to be used, a flushing system may be required in the foam concentrate injection system. Most Class A foam concentrates are less corrosive and therefore may not require flushing.

## J. Inject / Bypass Valve

The Inject/Bypass valve is mounted on the discharge side of the foam pump. This valve shall be accessible by the pump operator during normal operations. The valve is a 3-way directional valve that selects where the output of the foam pump will go.

Check to make sure the valve is installed properly. Look at the ports as you move the handle, the flow should go from the center port to each of the other ports.

The hose and fittings from the Inject port to the foam injector fitting should have minimum 3/8 inch inside diameter and be rated at 400 psi [28 BAR] minimum working pressure or maximum discharge pressure of the fire pump.

The hose from the Bypass port may have a lower pressure rating since it is plumbed to the atmosphere and will not receive high pressures. This hose is used for pumping the concentrate into a container to empty the tank or to assist in priming of the foam pump. The hose from the Bypass port must be long enough to reach a container outside the truck. This hose must be coiled for storage when not in use.



## SECTION 4. ELECTRICAL COMPONENTS

---

### Warnings:

Follow the system electrical diagram (**Error! Reference source not found.**) for proper hookup of each of the electrical components. Complete molded cable sets are provided with each Advantus system to make all the necessary connections.

The cables and receptacles are keyed so they only go in the correct receptacle and they can only go in one way.

DO NOT FORCE MISMATCHED CABLE CONNECTIONS. The system can only perform when the electrical connections are sound, so make sure each one is correct.

DO NOT hook up the main power cables until all of the connections are made to each of the electrical components. The last connection should be the power cable to the foam pump/motor base assembly.

Disconnect the leads of the battery.

DO NOT cut molded cables.

Make sure you provide at least 80 amps of electrical power for 12 VDC systems or 50 amps for 24 VDC systems from the battery to the main power terminal. Use 8 AWG (minimum) wire directly to the battery or battery switch.

This system is designed for 12 or 24 volt negative ground direct current systems only.

Use care when installing molded cables. Count pins before connecting. Bent pins caused by improper hookup can prevent proper operation even when cables are reattached properly.

If the seal washer is missing or damaged, water can enter the connector and cause corrosion of the pins and terminals that will cause system failure.

The cables shipped with each Advantus unit are tested at the factory with that unit. Improper handling and forcing connections can damage these cables which could result in other system damage.

Always disconnect the ground straps and control cables from the Operator Interface Terminal (OIT) or other Advantus equipment "**before**" electric arc welding at any point on the apparatus. Failure to do so may result in a power surge through the unit that could cause irreparable damage to the system components.

---

## A. Operator Interface Terminal (OIT)

Cables: 6 meter (standard)  
Option: 3 meter

The OIT (Display) is designed to be mounted in the operator panel of the apparatus. The cutout needed for the OIT, in the operator panel, is Figure 12 in back of this manual.

- The OIT is secured with four compression latches.

**Note:** Cables can be daisy chained to obtain longer lengths.



- The display requires 5 inches [127 mm] minimum from the back of the operator panel to clear cables and connectors.
- Once the OIT (Display) is mounted, connect the OIT (Display) cable from the motor driver box (on the Pump / Motor Driver Assembly) terminal to the 8 pin connector on the back of the OIT (Display).
- Make sure there is enough clearance behind the OIT assembly for the cables.
- Once the OIT assembly is mounted, connect the control cable (8 pin) from the control box terminal to the back of the OIT assembly (see Figure 4).
- Labels on the Control box identify each cable connection (see Figure 4).

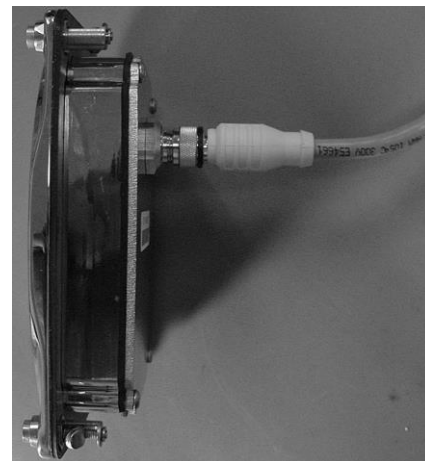

## B. Conductivity Probes

Cables: 3 meter (standard)  
Option: 2 meter

- Molded cables are supplied, which connects from the Conductivity Probe to the connectors on the Pump / Motor Driver Assembly (see Figure 4).
- The black conductivity probe that goes in the Clear Water manifold is considered "Clear". Cable is color coded "Black"

**Note:** Cables can be daisy chained to obtain longer lengths.

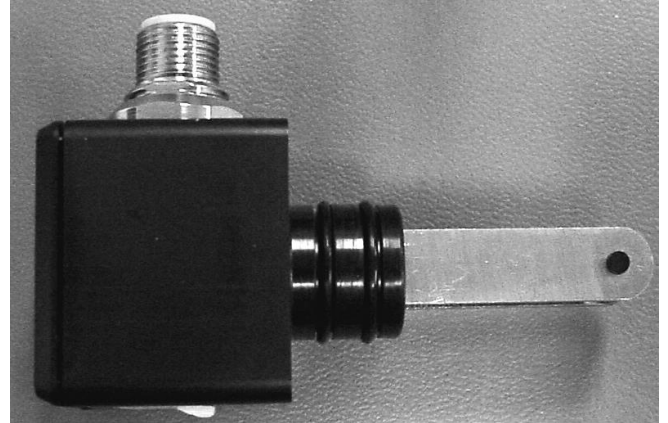
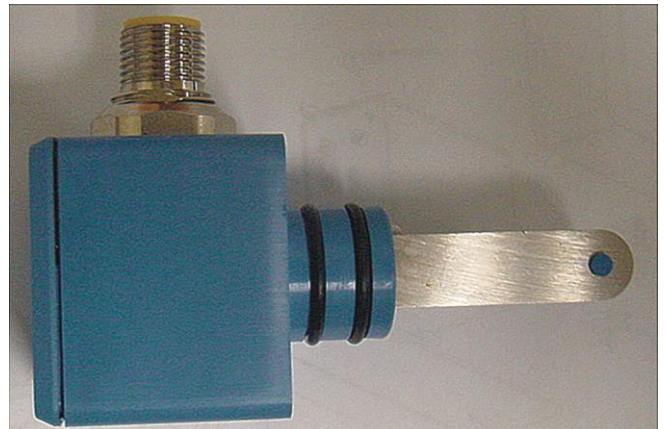

**Figure 6 Black Conductivity Probe**

Cables: 3 meter (standard)  
Option: 2 meter

- Molded cables are supplied, which connects from the Conductivity Probe to the connectors on the Pump / Motor Driver Assembly (see Figure 4).
- The blue conductivity probe that goes in the Foam Solution manifold is considered "Mix". Cable is color coded "Gray"

**Note:** Cables can be daisy chained to obtain longer lengths.



**Figure 7 Blue Conductivity Probe**

## C. Flow Sensor

Cables: 3 meter (standard)  
Option: 2 meter

A molded cable is supplied, which connects from the Flow sensor to the connector on the Pump / Motor Driver Assembly (see Figure 4).

**Note:** Cables can be daisy chained to obtain longer lengths.

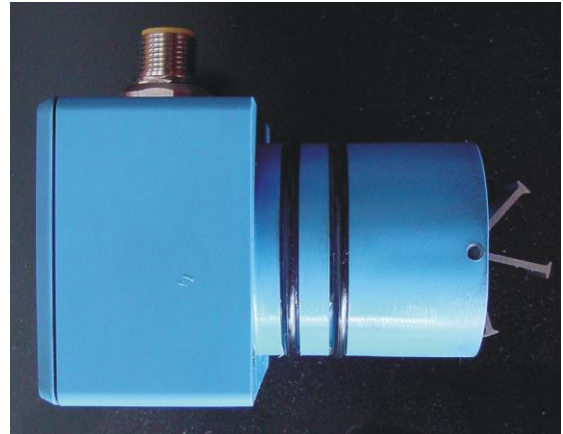

Figure 8 Flow sensor

## D. Cables and Ground

The manifolds must be grounded. If metal piping is used, sufficient grounding may be present. However, Victaulic joints, plastic pipe, rubber hoses and rubber mounted pumps interfere with proper grounding and an additional ground wire may be required.

Making round coils of extra OIT and Flow sensor cables in the pump compartment can act as an antenna. While the Flow sensor and OIT cables cannot be shortened, various lengths of cable are available to minimize the "extra" cable in the truck.

The gray cable goes from Manifold 1 Conductivity probe, to the Pump / Motor Driver Assembly cable connection, "Mix".

The black cable goes from the Manifold 2 Conductivity probe, to the Pump / Motor Driver Assembly cable connection, "Clear".

When routing the cables, take care to avoid routing them next to antenna cables, radio power lines and radio components. When there is extra cable, double the cable back on itself and secure in a flat bundle with plastic wire ties instead of making a round coil.



## SECTION 5. CALIBRATION AND SETUP

The Advantus system is able to be field calibrated using the control function buttons. Only units of measure, water flow and the foam percentage default can be field set.

### A. Entering Calibration Mode

1. Entering calibration is accomplished by using the control unit function buttons.
2. To enter this function press and hold the SELECT button for minimum of 5 seconds.
3. Continue to hold the SELECT button.
4. Then while the SELECT button is depressed, push the UP & DOWN arrow buttons at the same time. The display will show CAL for 2 seconds, and then display F1.
5. Use the UP Key to advance to the next parameter (F2, F3, F4).
6. Use the DOWN Key to back up to a previous parameter (F2, F1)
7. To edit a parameter, press the SELECT Key at the associated Fn Prompt.

### B. F1 - Default Mix Percentage

1. At the F1 prompt, press the SELECT button.
2. Use the **↑** or **↓** arrow buttons to select the default FOAM %. The only foam % selections are .1%, .2%, .3%, .4%, .5%, .6%, .7%, .8%, .9%, and 1.0%.
3. When finished, press the SELECT button to save the displayed value.

### C. F2 – Units of Measurement

The units of measurement must be selected prior to any calibration functions. Units of measurement are U.S. Gallons, Imperial Gallons and Liters.

1. Push the SELECT button at the F2 Prompt. The display will show the current setting.
2. Use the **↑** or **↓** arrow buttons to select one of the following measurement units.  
  
GAL will select U.S. Gallons.  
IPL will select Imperial Gallons.  
LTR will select Metric Liters.
3. Pushing the SELECT button will save the displayed selection.  
This will allow for calibration of the water flow in the units of measurement selected.

## D. F3 – Flow Rate Calibration

1. Press the SELECT button at the F3 prompt. The current measured flow rate will be displayed. Establish a flow using an accurate flow measuring device.
2. Once this is established, press the  $\uparrow$  or  $\downarrow$  arrow buttons to advance to the calibration step. If the displayed flow rate is correct, press the SELECT button to return back to the F3 prompt.  
  
If there is insufficient flow the display will show LoFL for 2 seconds, then return back to the F3 prompt.
3. The display will now display 50 (starting value), or the last calibration value entered.
4. Use the  $\uparrow$  or  $\downarrow$  arrow buttons to change the displayed value to match the actual flow rate according to the flow measuring device. If the button is only pressed momentarily, the display will increment or decrement by 1. If the button is held, the display will increment or decrement by 5.
5. Once the correct flow is achieved pushing the SELECT button will save the setting and return to the F3 prompt.

## E. F4 –System Lockout

System can be locked out after calibration and setup to avoid accidental changing.

**Warning:** A locked out system can only be unlocked at a qualified Waterous Service Center

1. Press the SELECT button at the F4 prompt and “EnAb” (enabled) will be displayed.
2. Pressing the UP $\uparrow$  button will toggle between “LoC” (locked) and “EnAb” (enabled). Settings will not be permanent until the calibration settings are saved.
3. Press the SELECT button and “F4” will be displayed.
4. Pressing the FOAM button, saves the settings, locks the system and can not be unlocked except at a qualified Waterous Service Center

**Note:** For V3.6 or newer, see “Advantus Troubleshooting guide” for unlocking calibration mode.

## F. F5 – Foam Select

- a) Press the SELECT button at the F5 prompt
- b) Pressing the ARROW  $\uparrow$  or  $\downarrow$  button will toggle between “A-A, b-b, A-b, A-F”  
Running A Foam in both tanks, select A-A  
Running B Foam in both tanks, select b-b  
Running A Foam in one tank and B Foam in the other tank, select A-b  
Running Combination (A-B) foam will do .1-.6%

## G. F6 – Simulated Water Flow (per NFPA testing)

- Press the SELECT button at the F6 prompt
- Pressing the Arrow  $\uparrow$  or  $\downarrow$  button will toggle between “0, 100, 200, 300” GPM simulated flow rate.
- Press SELECT.
- Press the FOAM button to exit Calibration mode.
- Displays the selected flow rate.
- Place a hose from the BYPASS into a bucket.
- Press FOAM, motor starts, foam pumps.
- Run for 2 or 3 minutes to equalize output.
- Measure the amount of concentrate in the bucket.
- To get out of “Simulated Water Flow”, you must get out of Calibration mode and come back to F6, setting water flow to Zero to get out of Simulated Water Flow mode.

Default Mix Percentage										
Flow Rate	.1%	.2%	.3%	.4%	.5%	.6%	.7%	.8%	.9%	1.0%
100	.1	.2	.3	.4	.5	.6	.7	.8	.9	1.0
200	.2	.4	.6	.8	1.0	1.2	1.4	1.6	1.8	2.0
300	.3	.6	.9	1.2	1.5	1.8	2.1	2.4	2.7	3.0
U.S. Gallons										

Highlighted numbers = ensure bucket is large enough to handle the volume

## F7 - Default Mix Percentage B foam

- At the F7 prompt, press the SELECT button.
- Use the  $\uparrow$  or  $\downarrow$  arrow buttons to select the default FOAM %. The only foam % selections are 1.0, 3.0 ,and 6.0 %
- When finished, press the SELECT to get out of F-function and press the RED button to save the displayed value.

## H. Saving Calibration

To save all the calibration settings to flash memory, press the FOAM button while at the Fn (n=1-6) prompt. The data will be stored, and the unit will return to normal operation.

Default Mix Percentage										
Flow Rate	.1%	.2%	.3%	.4%	.5%	.6%	.7%	.8%	.9%	1.0%
100	.1	.2	.3	.4	.5	.6	.7	.8	.9	1.0
200	.2	.4	.6	.8	1.0	1.2	1.4	1.6	1.8	2.0
300	.3	.6	.9	1.2	1.5	1.8	2.1	2.4	2.7	3.0
U.S. Gallons										

Highlighted numbers = ensure bucket is large enough to handle the volume

Foam default should be set to A-b or b-b

## SECTION 6. OPERATION

**Warning:** DO NOT run system with foam shutoff valve in the OFF position. Damage to foam pump will occur.

### A. Operating the System

Upon power up, the software revision number will be displayed. The unit will then display the flow rate.

Because the conductivity measurement for a given percentage mix changes with the flow rate, the calibration data is stored in an array. The array holds entries for the various parameters at several different flow rates. The software will perform a linear interpolation to determine values to use for flow rates that are in between flow rates entered in the data array.

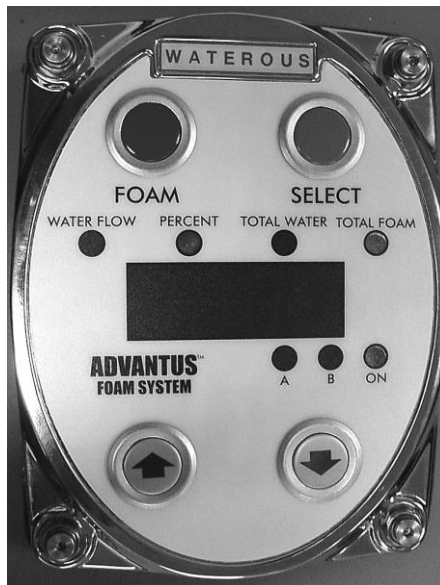

During normal operation, the OIT will display flow rate, percent mix, total water or total product.

#### **SELECT**

Selects data to display. The default is to display flow rate. Pressing the SELECT button will scroll through the list, then wrap back around to the top of the list. The associated LED will light to indicate what data is being displayed.

Flow Rate  
Mix Percentage  
Total Water  
Total Product

Holding the select button for more than 2 seconds, will lock the display to the current position. Pressing the select button again will unlock.

#### **UP ARROW**

When the Mix Percentage is displayed, the current mix setpoint will be displayed. Subsequent presses of the UP ARROW button will increase the Mix Setpoint by 0.1%. After a 10 second timeout, the display will return to the Flow Rate display.

## DOWN ARROW

When the Mix Percentage is displayed, the current mix setpoint will be displayed. Subsequent presses of the DOWN ARROW button will decrease the Mix Setpoint by 0.1%. After a 10 second timeout, the display will return to the Flow Rate display

Pressing both UP and DOWN simultaneously when the Total Water is displayed resets the Total Water accumulator to Zero.

Pressing both UP and DOWN simultaneously when the Total Product is displayed resets the Total Product accumulator to Zero.

Pressing both UP and DOWN simultaneously, for 2 seconds, when the Flow Rate is displayed enters the MANUAL mode of operation. See Manual Mode operation below.

Pressing both UP and DOWN simultaneously while in Mix % will go to the default %.

## FOAM

Pressing the FOAM key will alternately start and stop the foam operation. When the controller is running, the FOAM LED will be lit. The FOAM LED will blink when the motor control output is active. The LED will be lit and not blink during the initial pump delay, or when the system is on, but no water flow is detected.

If flow is detected, and one or both of the sensor inputs reads full scale, an open sensor error will be flagged. The error SEN1 or error SEN2 will be displayed when the FOAM button is pressed to indicate that the system is non-functional. In this case, the Manual Mode will be functional and must be used.



A Foam Tank



Optional B tank

## LCon (Low Concentrate)

If LCon error is displayed on the OIT, it will stay there for 2 minutes, the system will continue to run, then switches to NCON.



A Foam Tank



Optional B tank

**nCon**  
(no Concentrate)

If nCon error is displayed on the OIT, the display will stay there and the system will continue to run. But if the system is shut off and re-started, the Advantus will not start until the foam concentrate tank is filled.

**MANUAL MODE**

If the display is showing the flow rate, and the two ARROW keys are presses simultaneously, the % MIX LED will be lit and the display will show a default value of 2.0. Use the UP and DOWN arrow keys to increment or decrement this value in steps of 0.5.

Advantus 6 & 6 SSP	
Manual Mode Setting	Foam % @200 GPM
0.5	0.5%
1	1.0%
1.5	1.5%
2	2.0%
2.5	2.5%
3	3.0%

**Note:** Foam percentage in manual mode is approximate. Results are at 100 psi.

Pressing both ARROW keys again exits the MANUAL mode and stops the pump.

**Note:** Motor / Pump Assembly will operate in manual mode whether or not there is water flow. If the INJECT / BYPASS valve is in the INJECT position, foam concentrate will be injected into the system, which will waste concentrate.

**AUTO RUN**

The system is equipped with an AUTO RUN feature. If the voltage (+12 or 24 VDC) is applied to position 1 on the terminal strip, it will have the same effect as pressing the Red FOAM button. This will start the Foam system. The system will not inject foam until water is flowing.



**NFPA 1901 / 1906  
Advantus 6 Foam System Certification**

Certified Manufacturer Type Test

OEM Certification Test

Range		Water Flow	Range	Water Press. PSI	Range	Foam Cap. (gpm)
Min	10	Min	0	Min	.01	
Max	325	Max	400	Max	4.1	
Min	10	Min	400	Min	.01	
Max	325	Max	0	Max	6.8	
Mid	160	Mid	150	Mid	4.8	

Range		Test Points	Simulated Flow	Set Foam %	Range	Water Press. PSI	Range	Foam (gpm)
Min				Min			Min	
Mid				Mid			Mid	
Max				Max			Max	

**2 1/2" Foam Manifold**

Range		Water Flow	Range	Water Press. PSI	Range	Foam Cap. (gpm)
Min	20	Min	0	Min	.02	
Max	750	Max	400	Max	4.1	
Min	20	Min	400	Min	.02	
Max	750	Max	0	Max	6.8	
Mid	375	Mid	150	Mid	6.0	

Range		Test Points	Simulated Flow	Set Foam %	Range	Water Press. PSI	Range	Foam (gpm)
Min				Min			Min	
Mid				Mid			Mid	
Max				Max			Max	

**3" Foam Manifold**

Range		Water Flow	Range	Water Press. PSI	Range	Foam Cap. (gpm)
Min	30	Min	0	Min	.03	
Max	1200	Max	400	Max	4.1	
Min	30	Min	400	Min	.03	
Max	1200	Max	0	Max	6.8	
Mid	600	Mid	150	Mid	6.0	

Range		Test Points	Simulated Flow	Set Foam %	Range	Water Press. PSI	Range	Foam (gpm)
Min				Min			Min	
Mid				Mid			Mid	
Max				Max			Max	

Installer Certification  
Installed, Calibrated and Tested to Waterous AZ's Installation Recommendations and Purchaser's Performance Specifications

Tester: \_\_\_\_\_

Date: \_\_\_\_\_

This page has been intentionally left blank.



## SECTION 7. TROUBLESHOOTING CHART

Advantus Troubleshooting Chart		
Symptom	Probable Cause(s)	Corrective Action
1. Pump runs but produces no flow	Pump is not primed.	See Advantus instructions for priming instructions
	No foam in tank	Fill foam tank
	Foam tank valve closed	Open valve
	Strainer plugged	Remove and clean strainer
2. Pump loses prime	Check valves stuck in pump	Remove and clean check valves
	Air leak in suction hose or inlet fittings.	Remove suction hose and test for leaks by pressurizing hose with water. Make sure thread sealant has been used on all fittings.
	Suction line is blocked, collapsed or too small.	Remove suction line and inspect it for debris lodged in hose.
		Replace line with larger if it is too small. Avoid all unnecessary bends. Do not kink hose.
3. Proportioner uses excessive amounts of concentrate (runs rich)	Speed sensor position incorrect.	Reset speed sensor position by referring to manual for instructions.
	Paddle wheel out of calibration.	Calibrate paddle wheel flow per instructions in manual.
	System is in manual mode.	Depress up and down arrows simultaneously.
	Foam pump out of calibration.	Contact Waterous for reprogramming.
4. Proportioner uses too little of concentrate (runs lean)	Paddle wheel out of calibration.	Calibrate paddle wheel flow per instructions in manual.
	Foam pump out of calibration.	Contact Waterous for reprogramming.
	Foam pump low on oil.	Fill foam pump to correct level with oil.
	Pump diaphragm is ruptured.	Replace foam pump.
5. Pump runs full speed whenever the proportioner is either on or off	Faulty driver box.	Replace driver box.
6. Poor foam quality during low water flows	Foam percentage is too low.	Increase foam percentage.
	Foam strainer restricted.	Remove and clean foam strainer.
	Foam system calibration incorrect.	Re-calibrate.
	System not sized properly for application.	Contact Waterous.
7. Pump runs full speed whenever the proportioner is on	Poor ground to motor driver box on pump/motor	Make sure screws are tight and a good ground
8. OIT green light fails to illuminate when on button is depressed	Cables not correctly connected.	Inspect and secure connections.
	Inadequate ground.	Inspect and secure connections.
	Inadequate voltage.	Check voltage at system connection.
9. Proportioner will not inject concentrate.	Power not on.	Turn power on.
	Relief valve is set too low. (factory preset at 450 psi)	Reset relief to factory setting.
	Clogged piccolo tube.	Clean piccolo tube.
	Inject/Bypass valve in bypass position.	Move to inject position.
10. B light is on when using A tank and A tank is not selected on A/B selector valve	Pump diaphragm is ruptured.	Replace foam pump.
	Low level switch is wired to wrong terminal.	Move wire to correct terminal position.
11. System is powered up and the Foam ON/OFF switch has been pressed but the foam pump doesn't run.	Control cable(s) defective.	Replace control cable(s).
	No water is flowing in any of the foam discharges.	Flow water through a foam capable discharge.
	Poor paddle wheel connection.	Check and reconnect.
	Paddle wheel obstructed.	Clear paddle wheel of debris.
	Paddle wheel not functioning.	Replace paddle wheel.
12. N Con is displayed on OIT indicating no concentrate	Foam tank empty.	Fill foam tank.
	Float stuck on plunger—indicating tank is low.	Inspect and clean float switch.
	Low level sensor or wiring is inoperative.	Repair or replace defective components.
	Float installed incorrectly.	Reinstall float per instruction manual.
13. OIT fails to light up	Check master power on vehicle.	Turn on master power.
	Breaker switch has been tripped.	Reset breaker.
14. Green OIT light fails to flash while flowing water through foam manifold	Inoperative paddle wheel	Test by removing paddle wheel and spinning by hand. Replace paddle wheel if light still fails to flash.
	Poor paddle wheel cable connections.	Check connections.

## Advantus Troubleshooting Chart

Symptom	Probable Cause(s)	Corrective Action
15. Sen 1 or Sen 2 displayed on OIT	Conductivity sensor has failed.	Replace conductivity sensor.
	Conductivity sensor cable disconnected.	Reconnect conductivity sensor.
	Conductivity sensor shorted.	Remove conductivity sensor and clean probes.
16. OIT shows bars in the digital display area	Communication error.	Check connections on OIT and control box.
17. Delay in foam showing at nozzle	Low foam percentage and or low water flow.	Increase as needed.
	Foam inject check valve stuck open.	Replace foam inject check valve.
	Proportioner not primed.	Prime proportioner per instructions.
	A/B selector in flush position.	Move selector to A or B.
	Foam pump low on oil.	Fill foam pump to correct level with oil.
18. Foam in the water tank	Foam was poured in the wrong tank.	Flush water tank.
	Injection check valve stuck open.	Replace injection check valve.
	Foam manifold check valve fails to seal.	Inspect and clean or replace as necessary.
	Foam manifold drain is plumbed to master drain.	Isolate foam manifold drain.
19. Cannot access calibration mode.	Calibration lock out has been enabled.	Contact Waterous.
20. Inaccurate flow reading	Wrong units selected. (GAL, IPL, LTR)	Select correct units in F2 prompt in calibration mode.
	Improper calibration.	Check and re-calibrate.
21. For system equipped with overboard pick-up system fails to prime	Failure to vent injection line.	Open vent valve or Inject/Bypass valve.
	System not supplied with priming switch.	Add priming switch.

# SECTION 8. DRAWINGS

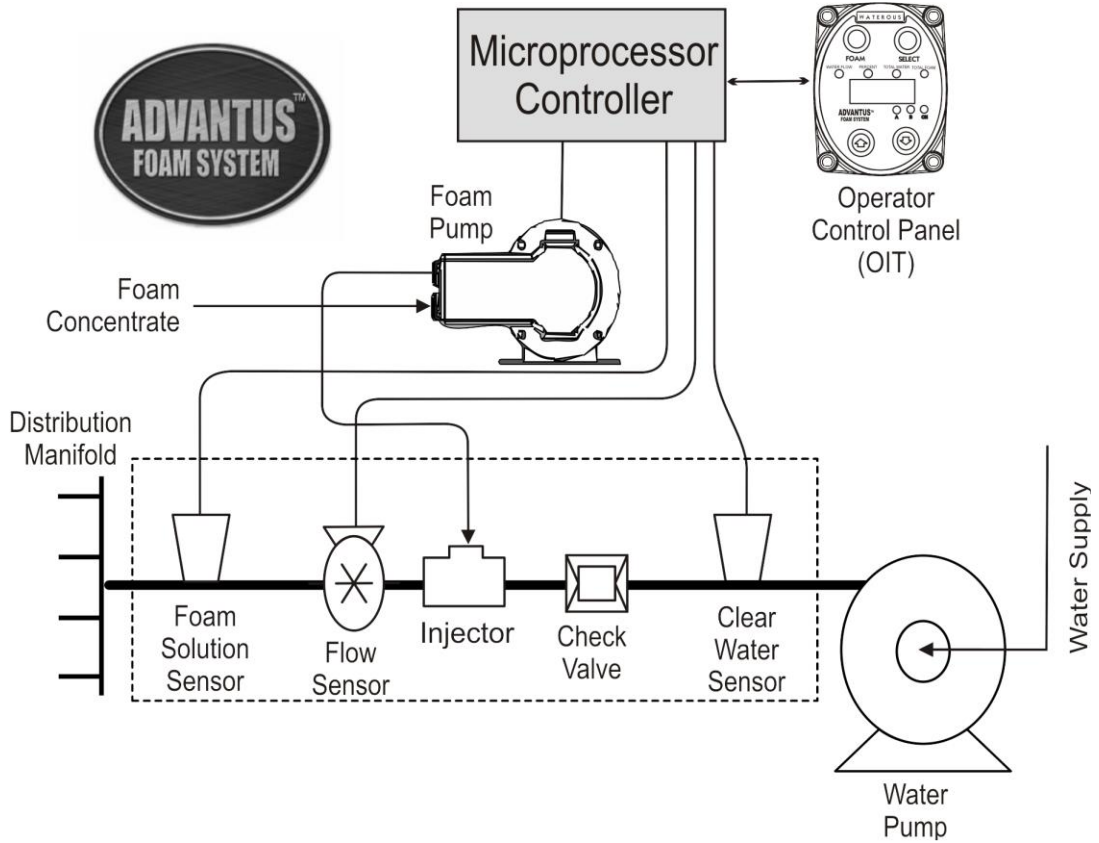
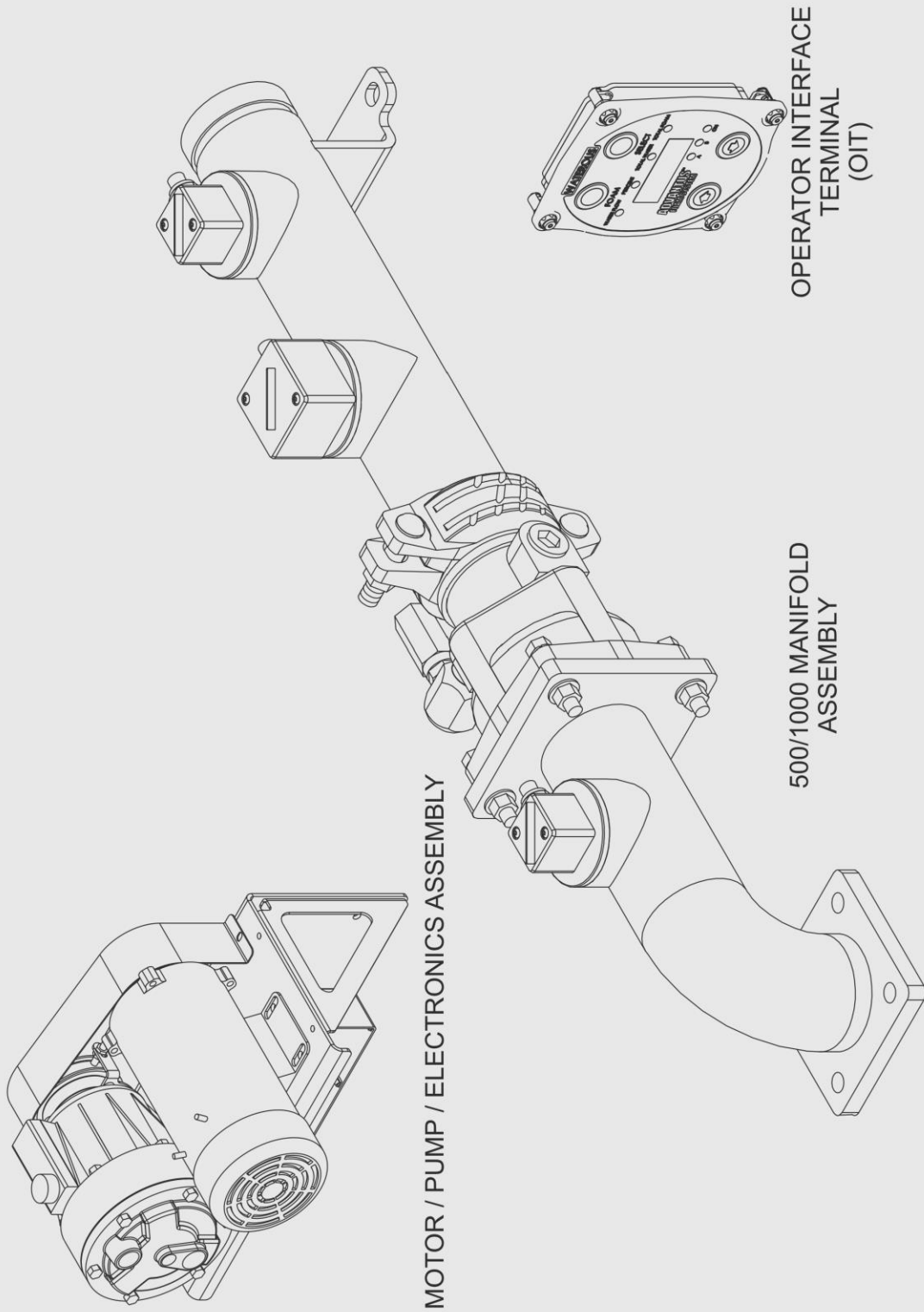

Figure 9 Basic System Schematic

ADVANTUS 6 SSP COMPONENTS



Drawings NOT to scale

**Figure 10 Components**

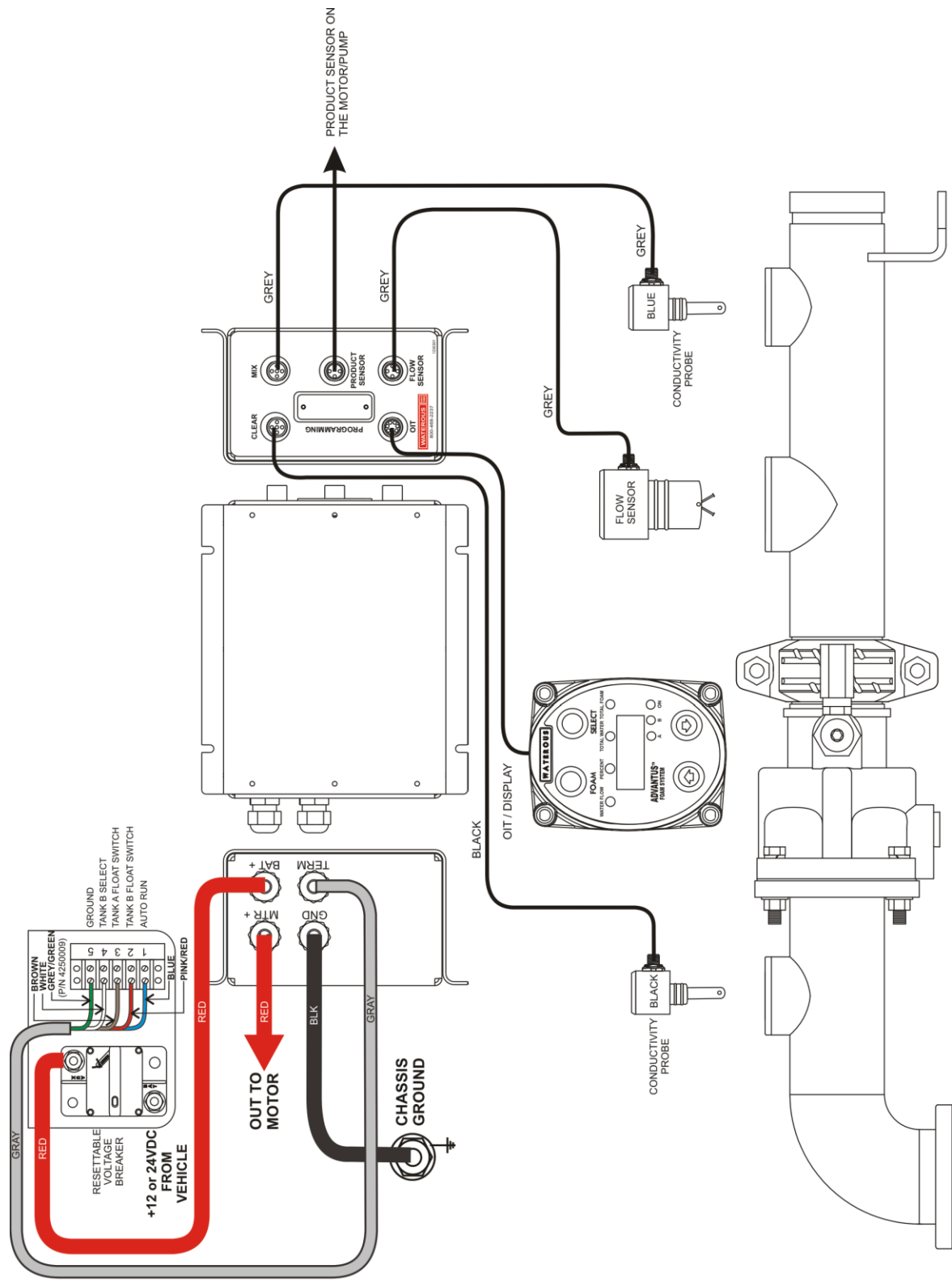
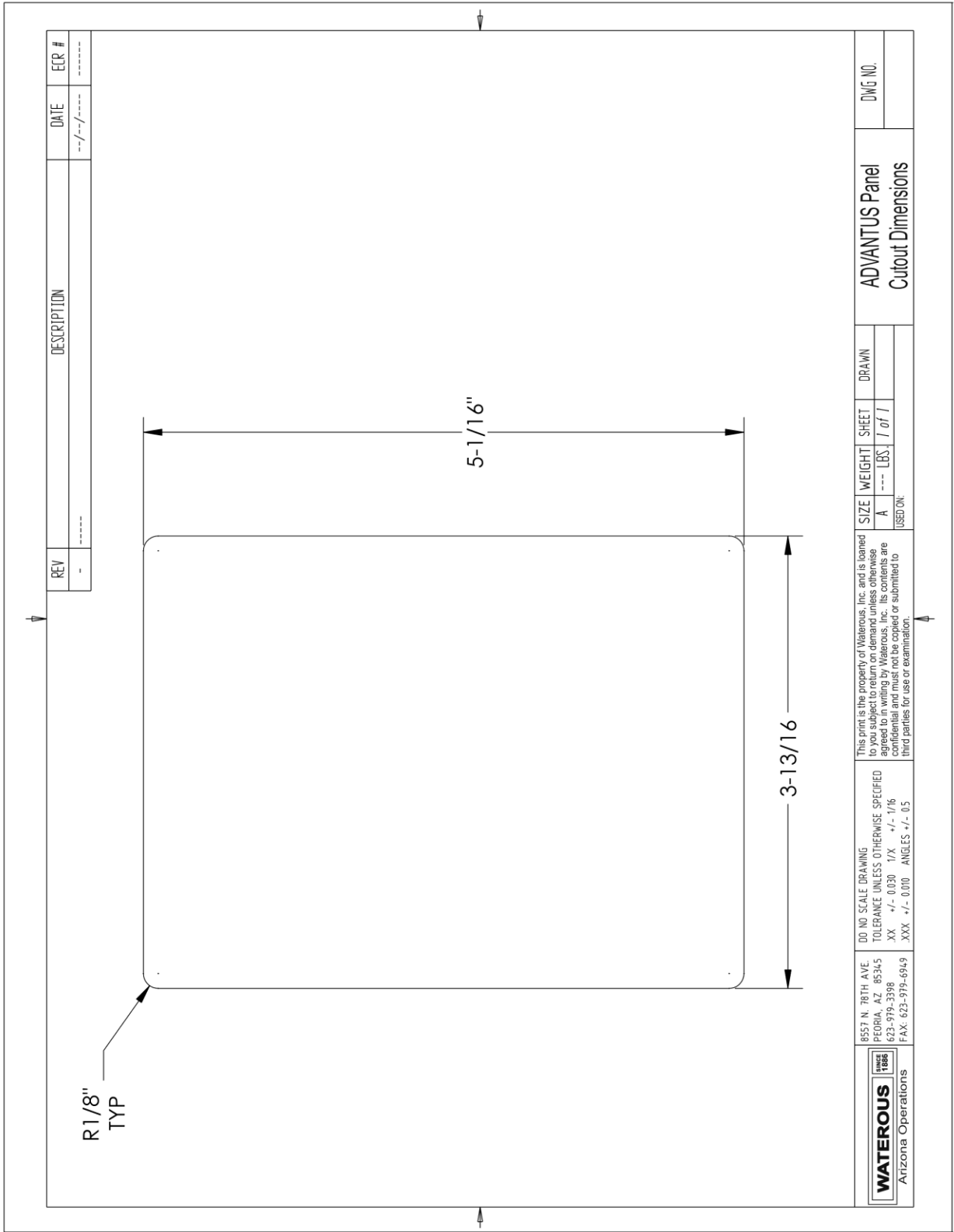

Figure 11 Electrical Schematic



**Figure 12 OIT (Display) Panel Cutout**

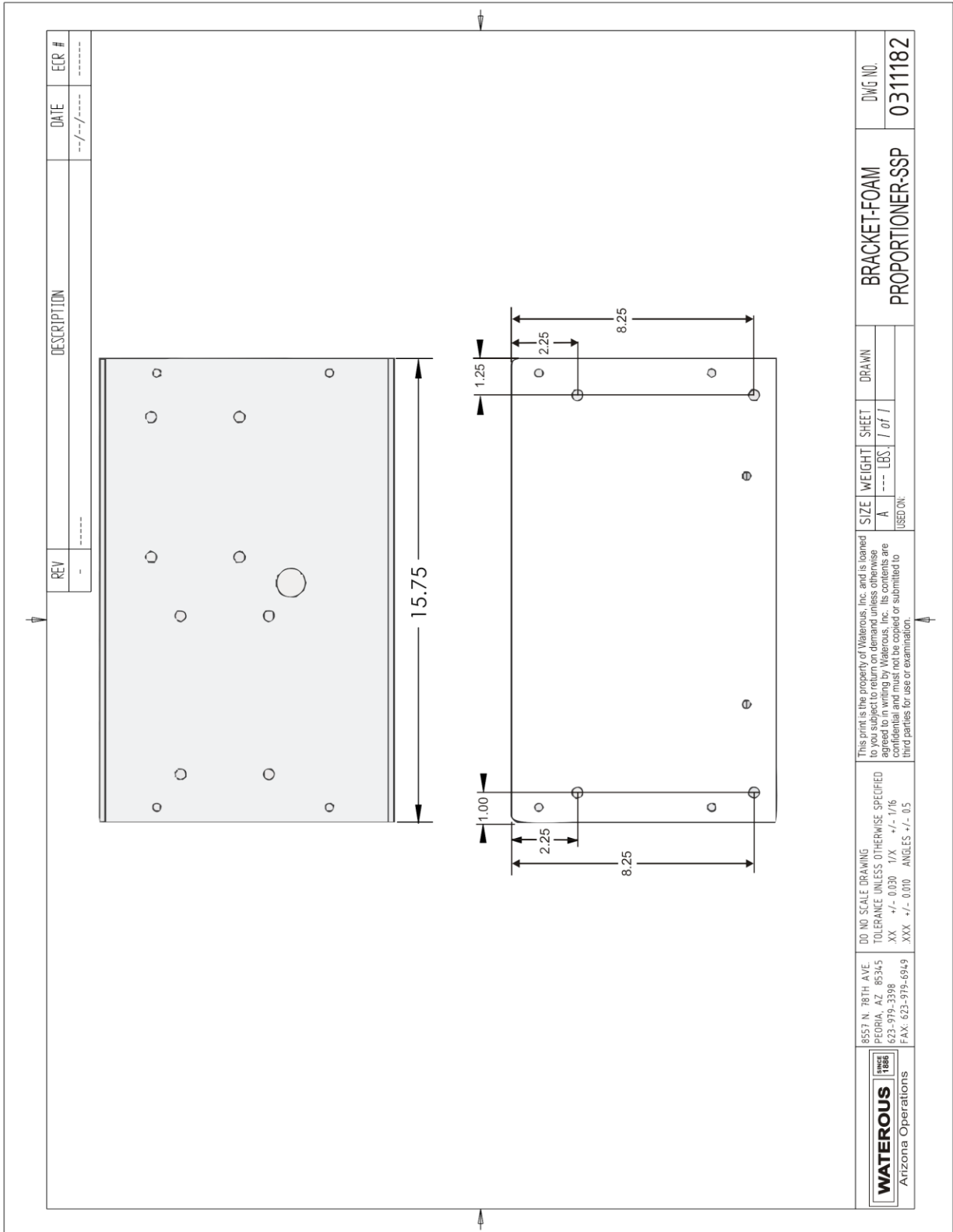

Figure 13 SSP Mount Bolt Pattern

# SECTION 9. ILLUSTRATED PARTS LIST

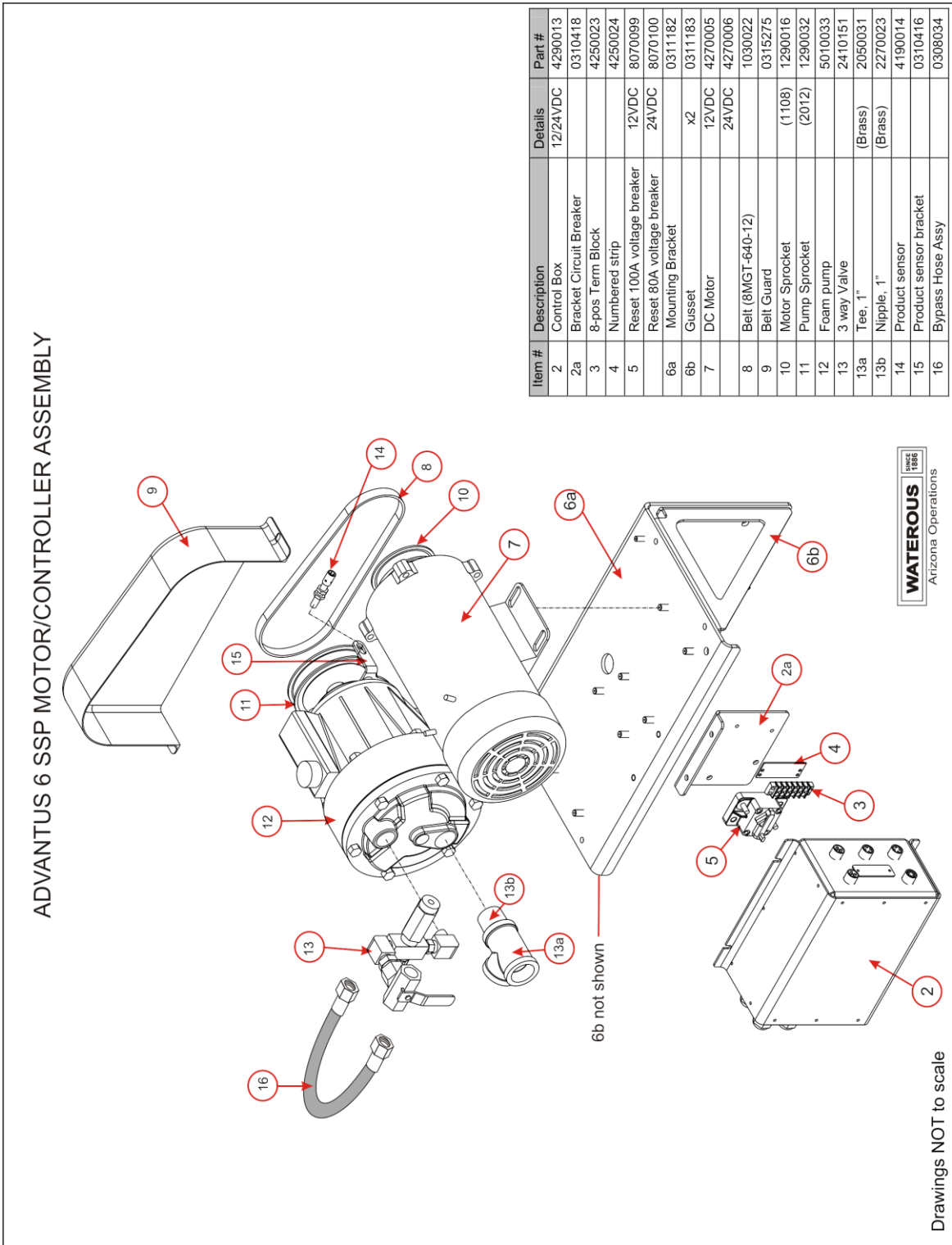

Figure 14 SSP Motor / Pump Assembly



Drawings NOT to scale

**ADVANTUS SSP MANIFOLD KIT**

500 GPM - PN:0390153  
 1000 GPM - PN:0390151

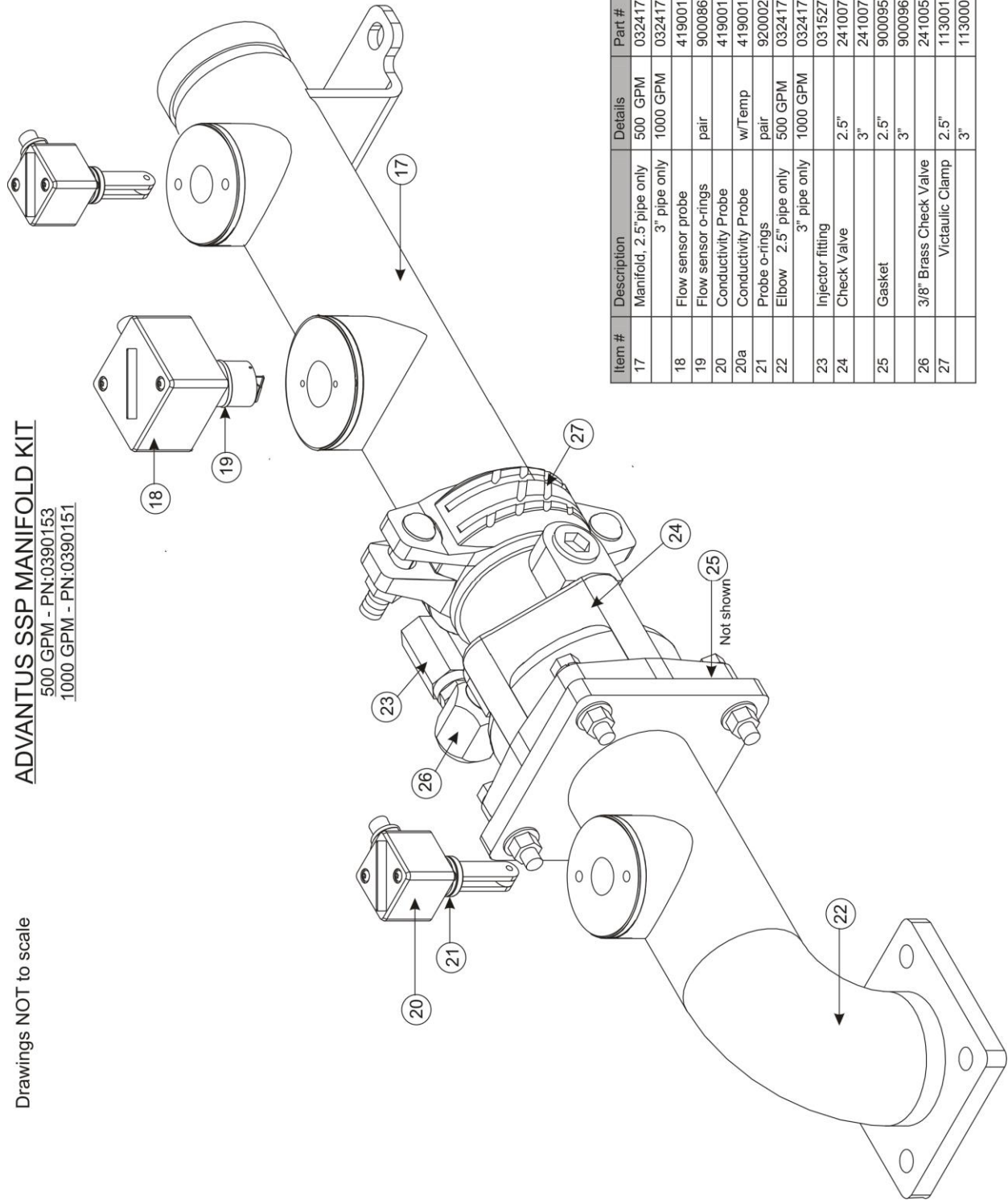

Item #	Description	Details	Part #
17	Manifold, 2.5" pipe only	500 GPM	0324170
	3" pipe only	1000 GPM	0324173
18	Flow sensor probe	pair	4190017
19	Flow sensor o-rings		9000860
20	Conductivity Probe		4190011
20a	Conductivity Probe	w/Temp	4190015
21	Probe o-rings	pair	9200021
22	Elbow 2.5" pipe only	500 GPM	0324171
	3" pipe only	1000 GPM	0324174
23	Injector fitting		0315273
24	Check Valve	2.5"	2410073
		3"	2410077
25	Gasket	2.5"	9000959
		3"	9000960
26	3/8" Brass Check Valve		2410055
27	Victaulic Clamp	2.5"	1130016
		3"	1130001

**Figure 15 Manifold Kit**

## SECTION 10. PART LIST

Part Number	Description
0310418	Bracket – Circuit Breaker
0315268	Vacuum Formed Cover
0315273	Foam Injector
0315275	Belt Guard
0324170	2-1/2" Manifold 1
0324173	3" Manifold 1
0324172	2-1/2" Elbow
0324174	3" Elbow
0390122	Cable Kit 1-Gray Conductivity Probe 3 M 1-Flow Probe 3M 1-OIT 6M 1-Black Conductivity Probe 3M 1-Tank Level Switch Cable 4M
1030022	Belt 8MGT-640-12
1290016	Sprocket, Motor
1290032	Sprocket, Pump
2410151	3 Way Ball Valve
2450004	1" Wye Strainer
4190000	Level Switch - Side
4190001	Level Switch - Top
4190011	Conductivity Probe
4190017	Flow-sensor (Paddle Wheel)
4190014	Product Sensor
4190015	Conductivity Probe w/temperature sensor
4270005	Motor - Washguard 1 HP 12VDC
4270006	Motor - Washguard 1 HP 24VDC
4290010	OIT Assembly
4290013	Control Box Assembly
4310000	Cable Conductivity Probe GY- 3M
4310001	Cable Conductivity Probe GY- 2M
4310002	Cable Flow-sensor Probe - 2M
4310003	Cable Flow-sensor Probe - 3M
4310010	Cable Product-sensor
4310006	Cable OIT - 3M
4310007	Cable OIT - 6M
4310008	Cable Conductivity Probe BK- 3M
4310009	Cable Conductivity Probe BK- 2M
4310014	Cable Tank Level Switch
5010033	Pump - Hydra-Cell D-10
9000959	Gasket, 2.5"
9000960	Gasket, 3"
9000860	Flow-meter O-rings (x2)
9200021	Conductivity Probe O-rings (x2)

## SECTION 11. WATEROUS 2-YEAR LIMITED WARRANTY POLICY

WATEROUS warrants, to the original Buyer only, that products manufactured by WATEROUS will be free from defects in material and workmanship under normal use and service for a period of two (2) years from the date the product is first placed in service, or two and one-half (2-1/2) years from the date of shipment by WATEROUS, whichever period shall be the first to expire; provided the Buyer notifies WATEROUS, in writing, of the defect in said product within the warranty period, and said product is found by WATEROUS to be nonconforming with the aforesaid warranty. When required in writing by WATEROUS, defective products must be promptly returned by Buyer to WATEROUS at WATEROUS' plant at South St. Paul, Minnesota, or at such other place as may be specified by WATEROUS, with transportation and other charges prepaid. A Returned Material Authorization (RMA) is required for all products and parts and may be requested by phone, fax, email, or mail. The aforesaid warranty excludes any responsibility or liability of WATEROUS for:

- (a) damages or defects due to accident, abuse, misuse, abnormal operating conditions, negligence, accidental causes, use in non-firefighting applications, or improper maintenance, or attributable to written specifications or instructions furnished by Buyer;
- (b) defects in products manufactured by others and furnished by WATEROUS hereunder, it being understood and agreed by the parties that the only warranty provided for such products shall be the warranty provided by the manufacturer thereof which, if assignable, WATEROUS will assign to Buyer, if requested by Buyer;
- (c) any product or part, altered, modified, serviced or repaired other than by WATEROUS, without its prior written consent;
- (d) the cost of dismantling, removing, transporting, storing, or insuring the defective product or part and the cost of reinstallation; and
- (e) normal wear items (packing, strainers, filters, light bulbs, anodes, intake screens, mechanical seals, etc.).

**ALL OTHER WARRANTIES ARE EXCLUDED, WHETHER EXPRESS OR IMPLIED BY OPERATION OF LAW OR OTHERWISE, INCLUDING ALL IMPLIED WARRANTIES OF MERCHANTABILITY OR FITNESS FOR A PARTICULAR PURPOSE. IN NO EVENT, WHETHER AS A RESULT OF BREACH OF CONTRACT, WARRANTY, TORT (INCLUDING NEGLIGENCE), STRICT LIABILITY, OR ANY OTHER CAUSE OF ACTION, SHALL WATEROUS BE LIABLE FOR ANY PUNITIVE, SPECIAL, INCIDENTAL OR CONSEQUENTIAL DAMAGES, OR FOR PERSONAL INJURY OR PROPERTY DAMAGES.**

The exclusive remedy of Buyer and the sole liability of WATEROUS, whether based on contract, warranty, tort or any other basis of recovery whatsoever, is expressly limited at the election of WATEROUS to:

- (a) the replacement at the agreed point of delivery of any product or part, which upon inspection by WATEROUS or its duly authorized representative, is found not to conform to the limited warranty set forth above, or
- (b) the repair of such product or part, or
- (c) the refund or crediting to Buyer of the net sales price of the defective product or part.

**BUYER'S REMEDIES CONTAINED HEREIN ARE EXCLUSIVE OF ANY OTHER REMEDY OTHERWISE AVAILABLE TO BUYER.**

Waterous Company  
125 Hardman Avenue South  
South St. Paul, MN 55075 USA  
[www.waterousco.com](http://www.waterousco.com)



Compressed Air Foam Systems