



Table of Contents

SECTION 1.	SAFETY, Everyone's Concern	3
SECTION 2.	INSTALLATION PLANNING	4
SECTION 3.	PLUMBING COMPONENTS	6
A.	Motor / Pump Assembly	6
I.	Power Supply	7
II.	Motor / Pump / Controller	7
III.	Pump Maintenance	8
B.	Wye Strainer	9
C.	Flow Sensor	9
D.	Flow Tee	10
E.	Foam Injection Check Valve	10
F.	Drain Lines	10
G.	Flushing System	11
H.	Inject/Bypass Valve	11
SECTION 4.	ELECTRICAL COMPONENTS	12
A.	Operator Interface Terminal (OIT)	13
B.	Flow Sensor	14
C.	Cables	14
SECTION 5.	CALIBRATION AND SETUP	15
A.	Entering Calibration Mode	15
B.	F1 - Default Mix Percentage	15
C.	F2 - Units of Measurement	15
D.	F3 - Flow Rate Calibration	16
E.	F4 - System Lockout	16
F.	F5 - Foam Select	16
G.	F6 - Simulated Water Flow (per NFPA testing)	17
H.	Saving Calibration	17
SECTION 6.	OPERATION	18
A.	Operating the System	18
SECTION 7.	TROUBLESHOOTING CHART	23
SECTION 8.	DRAWINGS	25
SECTION 9.	PART LIST	30
SECTION 10.	WATEROUS 1-YEAR LIMITED WARRANTY POLICY	31



Read through the installation instructions carefully.

NOTE: Instructions subject to change without notice.

Warnings, Cautions, and Notes

Warning: A warning alerts you to a procedure, practice or condition that may result in death or long term injury to personnel or destruction of equipment.

Caution: A caution alerts you to a procedure or condition that may result in serious damage to equipment or its failure to operate as expected

Note: A note points out important information. Failure to read the note may not result in physical harm to personnel or equipment. It may waste time and money.

Revision History

Revision	Date Issued	Comments
-	12/28/2007	Initial Release
1	11/9/09	updated pg 17 section B Added F5, F6 to the Calibration section & priming mode (in operations), updated fig 5 & fig 6
2	7/22/10 8/6/10	Added Foam Cert, added Pump maintenance
3	1/7/11	Added troubleshooting Chart
4	5/9/11	Added Flow Tee drawing
5	8/3/11 11/10/11	Changed Terminal block drawing Added Motor / Pump Orientation pic

Disclaimer: These instructions are guidelines only and in no way meant to be definitive. During installation, standard safety precautions and equipment should be used where appropriate. Because the tools used and the skill/experience of the installer can vary widely, it is impossible to anticipate all conditions under which this installation is made, or to provide cautions for all possible hazards. Proper installation is the responsibility of the purchaser. All bolts, setscrews, and belts must be checked prior to start-up AND after the initial operation. Damages due to poor installation are the responsibility of the installer.

Waterous reserves the right to make modifications to the system without notice

Figure(s)

Figure 1 AQUIS 2.5 Motor / Pump assembly.....	6
Figure 2 Terminal block locations	7
Figure 3 Small Terminal Block / Schematic	8
Figure 4 Paddle-wheel Tee.....	10
Figure 5 Foam Injection Check Valve	10
Figure 6 Flow sensor	14
Figure 7 Basic System Schematic	25
Figure 8 OIT (Display) Panel Cutout.....	26
Figure 9 Aquis Z Bracket Mount Bolt Pattern	27
Figure 10 Motor – Pump orientation NORMAL.....	28
Figure 11 Motor – Pump orientation REVERSED	28
Figure 12 Aquis Flow Tees	29

SECTION 1. SAFETY, Everyone's Concern

Please read all of the following safety precautions and follow carefully. They are important to the prevention of personal injury or damage to the equipment.

1. Do not pump at pressures higher than the maximum recommended pressure. [400 psi (28 BAR)]
2. Do not permanently remove or alter any guarding devices or attempt to operate the system when these guards are temporarily removed.
3. Always disconnect the power source before attempting to service any part of the pump.
4. Release all pressure within the system before servicing any of its components.
5. Drain all concentrate and water from the discharge system before servicing any of its component parts.
6. Check all hoses for weak or worn conditions on a regular basis. Ensure that all connections and fittings are tight and secure.
7. Use only pipe, hose, and fittings from the foam pump outlet to the injector fitting, which are rated at or above the maximum pressure [400 psi (28 BAR) minimum] rating at which the water pump system operates.
8. Any electrical system has the potential to cause sparks during service. Take care to eliminate explosive or hazardous environments during service/repair.

Caution: Do not attempt to operate the system at or above a temperature of 160°F (71°C)

Ensure that the electrical source of power for the unit is the appropriate 12 or 24 volt, negative ground DC system, with a minimum current rating of at least 60 amps for 12 VDC or 30 amps for 24 VDC System.

Periodically inspect the pump and the system components. Perform routine preventive maintenance as required. Failure to perform routine maintenance may cause damage to the pump.

Read and understand "Operation" section before attempting to operate the unit.

Always disconnect the ground straps and control cables from the control module or other Aquis equipment before electric arc welding at any point on the apparatus. Failure to do so will result in a power surge through the unit that could cause irreparable damage to the system components.

The cables shipped with each Aquis unit are tested at the factory. Improper handling and forcing connections can damage these cables which could result in other system damage.

This document explains how to set up and operate the Aquis Foam Control system.

SECTION 2. INSTALLATION PLANNING

The Waterous recommends that you spend time planning where and how you intend to install this unit in the equipment before beginning the actual installation.

Determine the locations of the components to be installed such as; foam tank, Motor / Pump Assembly, Manifold and OIT.

- Locate the pump as close to the supply source as possible. Install it in a clean space where it will be easy to inspect and maintain. Allow room for checking the oil level, changing the oil, and general servicing.
- Try to place components in locations that require the least amount of cables, hoses and fittings.
- Position the Motor / Pump Assembly in an area that is protected from road debris and excessive heat buildup.
- It is recommended that the Motor / Pump Assembly be installed in an accessible compartment located in the vicinity of the Operator Interface Terminal (OIT) panel.
- Place the foam tank so that the refilling can be done safely.
- Most water tank manufacturers will build the foam tank into the booster tank.
- When specifying a integral foam tank, make sure provisions are made for installation of the optional low tank level sensor as well as foam suction connections and tank drainage according to NFPA.

Determine a location for the Operator Interface Terminal (OIT) on the operator panel of the equipment.

- Consider the routing path of the cable from the Operator Interface Terminal (OIT) to the Pump / Motor Driver Assembly.
- If necessary, order extension cables to suit the location demands.

Warning: Never attempt to cut or lengthen the molded cables. Cables can be daisy chained to obtain longer lengths.

Always disconnect the ground straps and control cables from the Operator Interface Terminal (OIT) or other Aquis equipment **“before”** electric arc welding at any point on the apparatus. Failure to do so could result in a power surge through the unit that could cause irreparable damage to the electronic components.

Cautions: **Ensure Adequate Concentrate Supply.**
Aquis 2.5 - a minimum of ¼ inch ID tubing

Safety Guards.
Follow all codes and regulations regarding installation and operation of the Aquis system.

Shut-Off Valves.
Never install shut-off valves between the pump and discharge pressure regulator, or in the regulator bypass line.

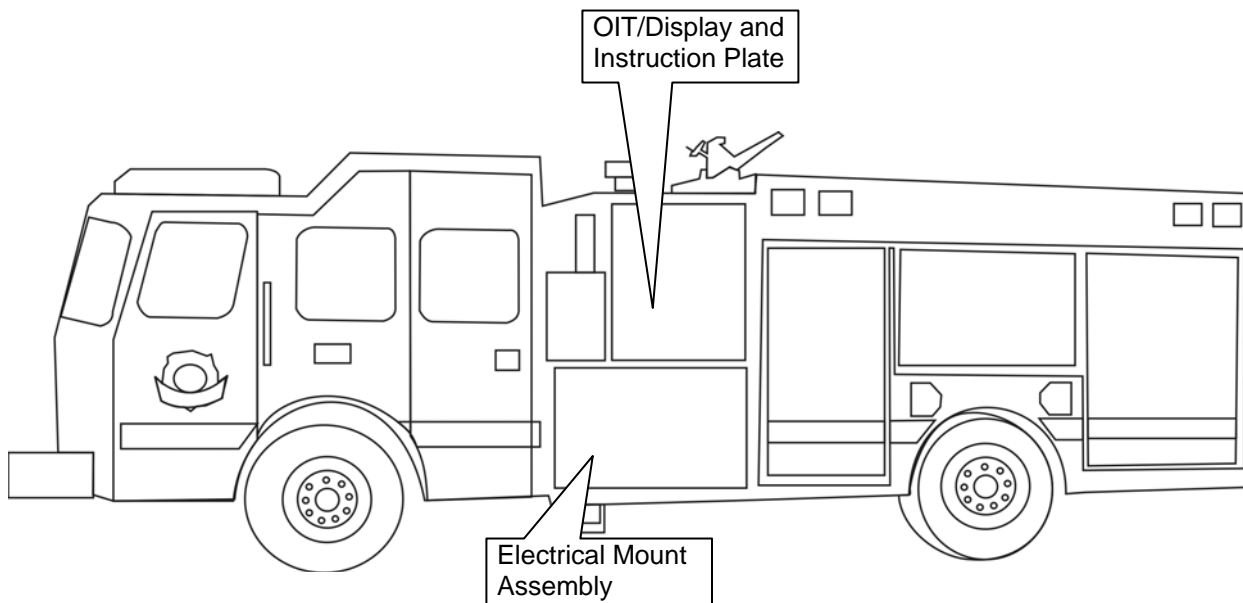

SECTION 3. PLUMBING COMPONENTS

A. Motor / Pump Assembly

The Motor / Pump Assembly must be mounted horizontally. The base must be anchored to a surface or structure that is rigid and of adequate strength to withstand the vibration and stresses of apparatus operation.

Flexible hose is required to make the hose connections from the Motor / Pump Assembly to the foam tank.

DO NOT hard pipe the system.

Consider access requirements for checking the foam pump. Be sure the foam concentrate hoses can be properly routed to the inlets and outlets on the foam pump.

Foam concentrates should gravity feed to the foam pump inlet from the foam tank. However the systems are capable of drafting up to 1 meter vertically. The Motor / Pump Assembly must be mounted in an area to avoid excessive exhaust system heat buildup.

Protect the hoses and wiring to prevent chafing and abrasion during operation of the foam system.

Protect the Motor / Pump Assembly from excessive road spray and debris. Although the system is sealed and designed to be resistant to the harsh environment of fire fighting apparatus, a protected compartment with easy operator access is the recommended installation location.

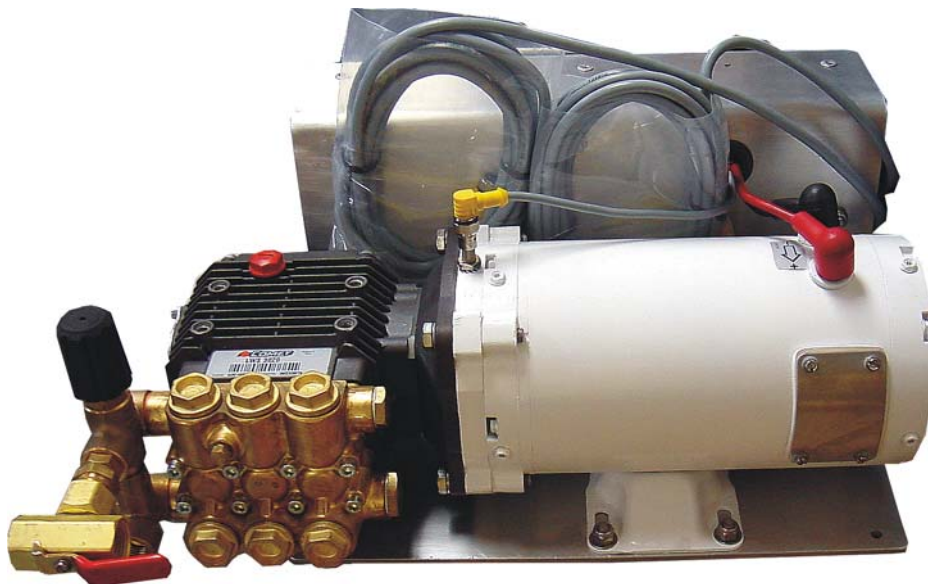

Figure 1 AQUIS 2.5 Motor / Pump assembly

The large circuit breaker (Figure 2) is used to connect the 12 VDC input power.

Make sure you provide adequate electrical power (60 amps minimum for 12 VDC or 30 amps for 24 VDC) from the battery. Use 8 AWG (minimum) wire directly to the battery or battery switch. Long wire runs may require 6 or 4 AWG wire for proper operation.

Recommended wire sizes	
Wire Size	Wire Length (approx.)
8 awg	10-20 feet
6 awg	20 feet to 30 feet
4 awg	30 feet or more

I. Power Supply

Electrical devices can be easily damaged by a weak or erratic power supply. The better the power supply, the better the Aquis system will perform. At maximum output, the Aquis system can draw 60 amps at 12 VDC or 30 amps at 24 VDC.

Connect the ground lead from the chassis frame or the negative battery terminal. Use the same size wire as the power lead.

DO NOT connect the main power leads to small leads that are supplying some other device such as a light bar or siren.

CAUTION: Be careful not to damage or short circuit the wires leading to the circuit breaker. Only the Aquis system is protected by the circuit breaker.

II. Motor / Pump / Controller

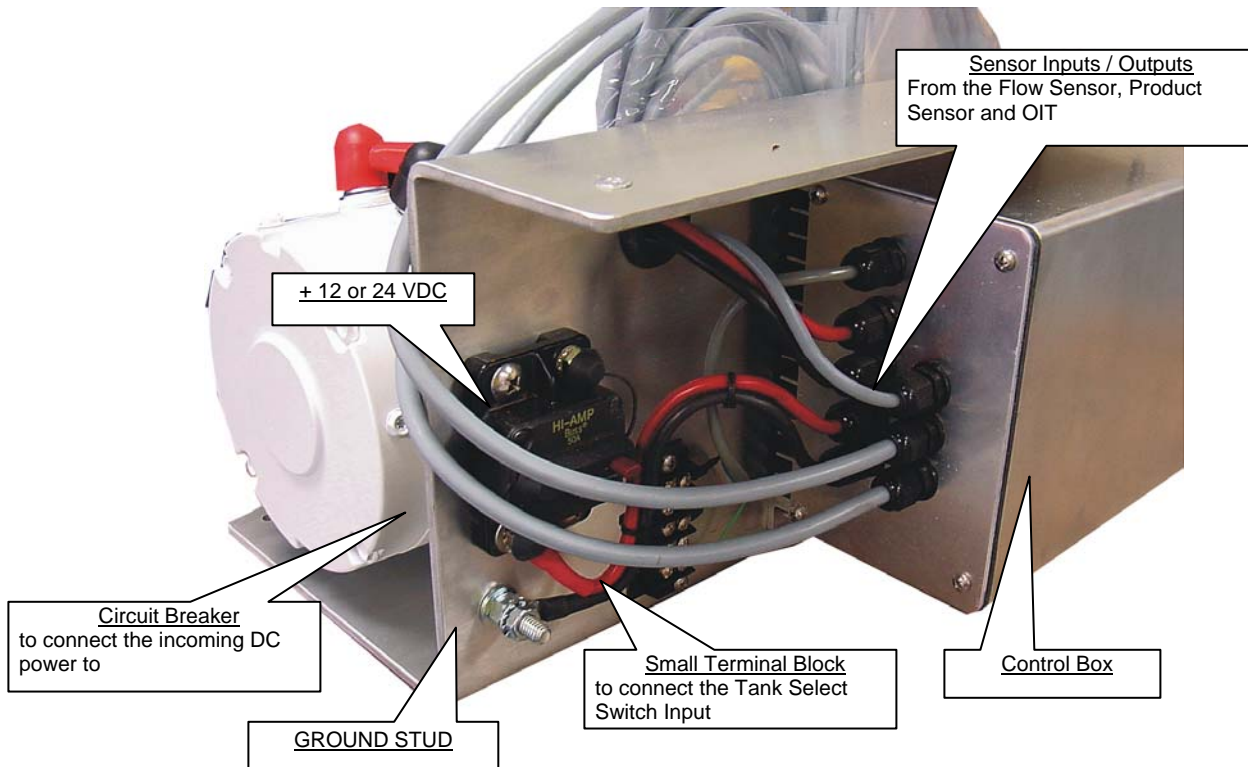

Figure 2 Terminal block locations

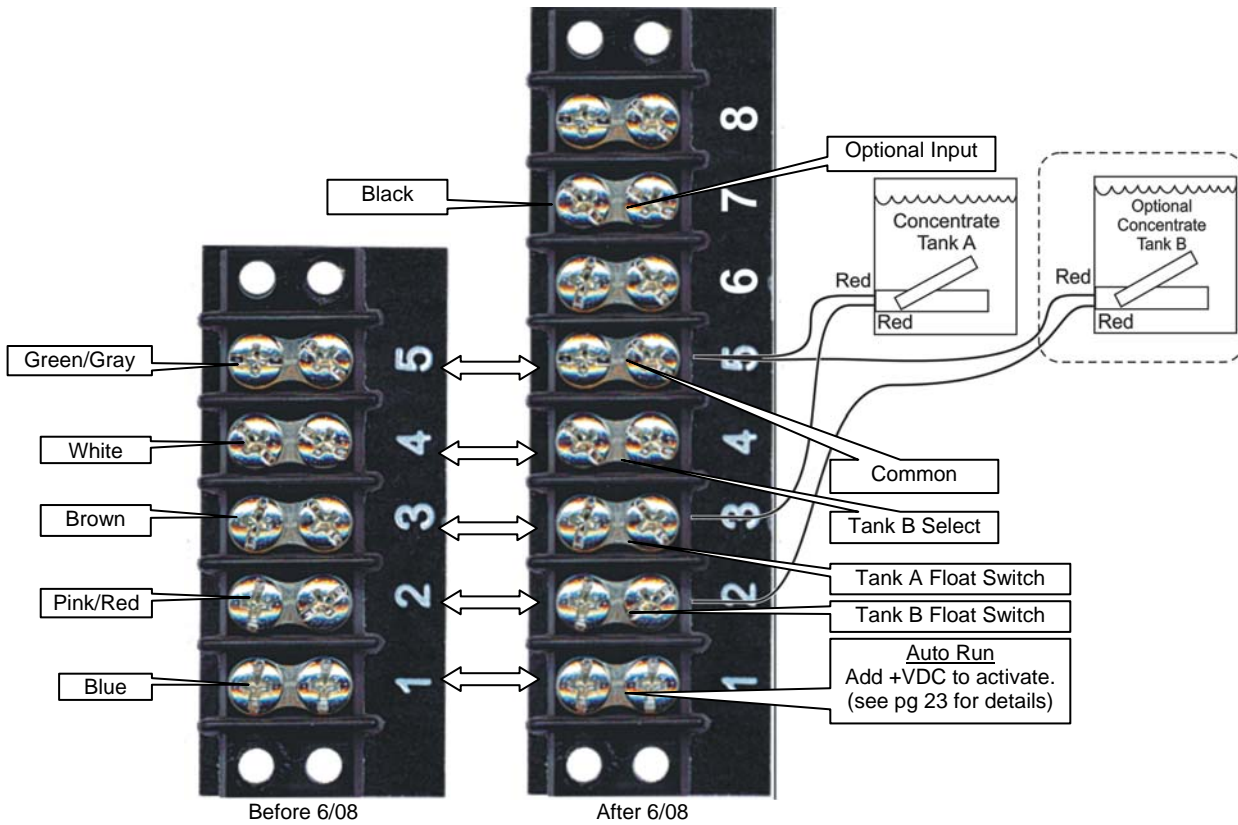

Figure 3 Small Terminal Block / Schematic

There are no user serviceable parts inside the Control Box. All power and ground cables will come with the new box

III. Pump Maintenance

a) Daily

Check the oil level and the condition of the oil. The oil level should be 3/4 in. (20 mm) from the top of the fill port.

Use the appropriate pump oil or equivalent, motor oil for the application (SAE 10W/30).

Manufacturer's recommendations

OPERATION	Every 8 hours	Every 50 hours	Every 500 hours
Check oil level	X		
Check tubes-fittings		X	
Check & clean inlet filter		X	
Control pump connection to the engine		X	
Change oil		X –First change	X
Check suction/delivery valves			X
Check pump bolt and nut setting			X
Check regulation valve			X

b) Periodically

Change the oil after the first 50 hours of operation, and every 500 operating hours thereafter. When changing, remove the drain plug at the bottom of the pump so all oil and accumulated sediment will drain out.

Check the inlet pressure or vacuum periodically with a gauge.

-
- Caution:**
- **DO NOT** turn the drive shaft while the oil reservoir is empty.
 - Protect the pump from freezing.
-

B. Wye Strainer

The line strainer provided with the unit has 3/4 inch NPT female threaded ports will need to be installed, in-line, between the foam supply tank and the foam pump. The hose from the foam tank should have adequate wall stiffness to withstand the vacuum of the foam pump while it is operating.

NOTE: If a pressurized water flush from one of the discharges is incorporated, the plumbing and line strainer exposed to this pressure must be rated at or above the operating pressure of all other discharge plumbing components.

C. Flow Sensor

The flow sensor (paddle-wheel) measures the water flow through the foam manifold system and sends the information to the Control Box and OIT Display. (Figure 6)

The flow sensor requires that the amount of turbulence be as low as possible. Excessive turbulence produces unstable and inaccurate flow readings. The following installation guidelines will help attain the best readings and maintain accuracy of the displayed value.

- a. The standard and minimum of 5 times the pipe diameter of straight run pipe without any fittings is preferred upstream of the flow sensor. 10 times is even better — the longer the straight run, the lower the turbulence.
- b. The downstream plumbing of the flow sensor is not critical; but again, straight runs without fittings help maintain accurate flow readings.
- c. Last, try to mount the flow sensor in a position that is accessible for routine inspection and maintenance.

D. Flow Tee

In horizontal runs, the Tee should be mounted upright.

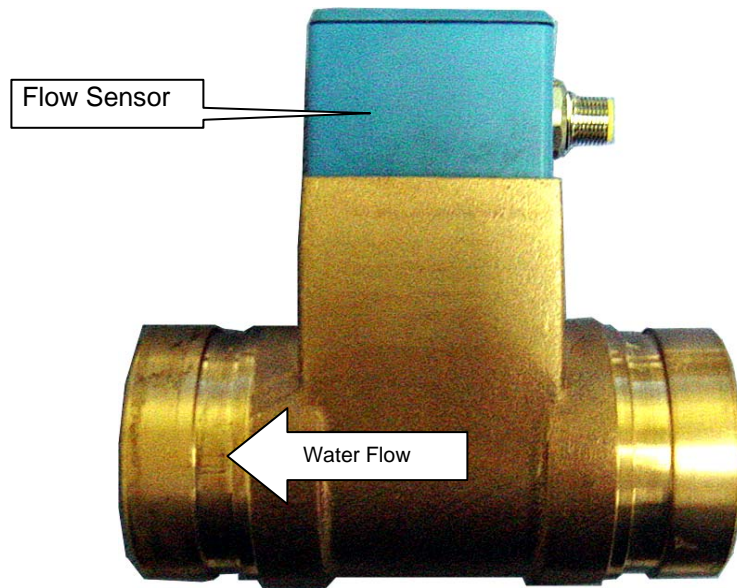

Figure 4 Paddle-wheel Tee



Figure 5 Foam Injection Check Valve

E. Foam Injection Check Valve

A 3/8 inch check valve meets NFPA requirements for a non-return device in the foam injection system.

DO NOT OVER TIGHTEN.

The check valve in the water way is required to keep foam solution out of the main pump and allow pump priming without drawing foam into the piping.

F. Drain Lines

On apparatus with multiple drain lines, the drains from the foam solution discharge line should not be piped into a multi drain system before the check valves. The standard multi drain system from most manufacturers will allow cross talk between the drain lines and the apparatus water tank, resulting in

contamination of the water tank with foam. A separate drain system should be provided for foam solution piping to prevent contamination of the water tank and fire pump.

G. Flushing System

Depending on the corrosiveness of the foam concentrates to be used, a flushing system may be required in the foam concentrate injection system. Most Class A foam concentrates are less corrosive and therefore may not require flushing.

H. Inject/Bypass Valve

The Inject/Bypass valve is mounted on the discharge side of the foam pump. This valve shall be accessible by the pump operator during normal operations. The valve is a 3-way directional valve that selects where the output of the foam pump will go.

Check to make sure the valve is installed properly. Look at the ports as you move the handle, the flow should go from the center port to each of the other ports.

The hose and fittings from the Inject port to the foam injector fitting should have minimum 3/8 inch inside diameter and be rated at 400 psi [28 BAR] minimum working pressure or maximum discharge pressure of the fire pump.

The hose from the Bypass port may have a lower pressure rating since it is plumbed to the atmosphere and will not receive high pressures. This hose is used for pumping the concentrate into a container, to empty the tank or to assist in priming of the foam pump. The hose from the Bypass port must be long enough to reach a container outside the truck. This hose must be coiled for storage when not in use.



SECTION 4. ELECTRICAL COMPONENTS

Warnings: Complete molded cable sets are provided with each Aquis system to make all the necessary connections and are integrated in the control box.

The cables and receptacles are keyed so they only go in the correct receptacle and they can only go in one way.

DO NOT FORCE MISMATCHED CABLE CONNECTIONS. The system can only perform when the electrical connections are sound, so make sure each one is right.

DO NOT hook up the main power cables until all of the connections are made to each of the electrical components. The last connection should be the power cable to the foam pump/motor base assembly.

DO NOT cut molded cables.

Make sure you provide at least 60 amps of electrical power for 12 VDC systems or 30 amps for 24 VDC systems from the battery to the main power terminal. Use 8 AWG (minimum) wire directly to the battery or battery switch.

This system is designed for 12 or 24 volt negative ground direct current systems only.

Use care when installing molded cables. Count pins before connecting. Bent pins caused by improper hookup can prevent proper operation even when cables are reattached properly.

If the cable connection seal washer is missing or damaged, water can enter the connector and cause corrosion of the pins and terminals that will cause system failure.

The cables shipped with each Aquis unit are tested at the factory with that unit. Improper handling and forcing connections can damage these cables which could result in other system damage.

Always disconnect the ground straps and control cables from the Operator Interface Terminal (OIT) or other Aquis equipment "**before**" electric arc welding at any point on the apparatus. Failure to do so may result in a power surge through the unit that could cause irreparable damage to the system components.

A. Operator Interface Terminal (OIT)

Cables: 3 meter (standard)

The OIT (Display) is designed to be mounted in the operator panel of the apparatus. The cutout needed for the OIT, in the operator panel, is Figure 8 in back of this manual.

- The OIT is secured with four compression latches.

Note: Extension cables can be daisy chained to obtain longer lengths.



- The display requires 5 inches [127 mm] minimum from the back of the operator panel to clear cables and connectors.
- Once the OIT (Display) is mounted, connect the OIT (Display) cable from the motor driver box (on the Pump / Motor Driver Assembly) terminal to the 8 pin connector on the back of the OIT (Display).
- Make sure there is enough clearance behind the OIT assembly for the cables.
- Once the OIT assembly is mounted, connect the control cable (8 pin) from the control box to the back of the OIT assembly.

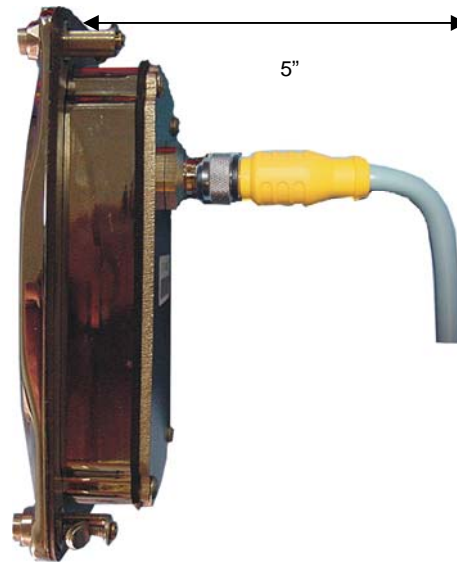

B. Flow Sensor

Cables: 3 meter (standard)

A molded cable is supplied, which connects from the Flow sensor to the Control box of the Pump / Motor Driver Assembly.

The sensor has a built in temperature sensor.

Note: Extension cables can be daisy chained to obtain longer lengths.

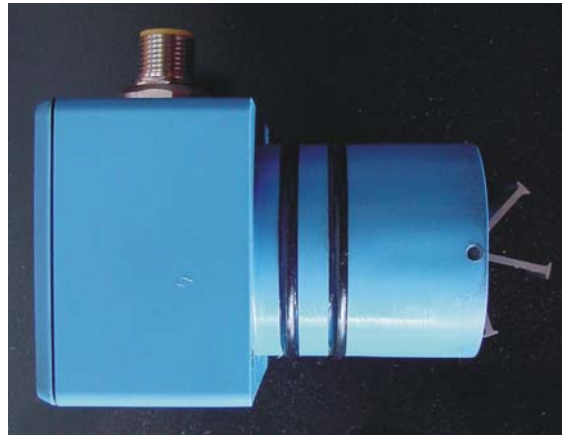

Figure 6 Flow sensor

C. Cables

Making round coils of extra OIT and Flow sensor cables in the pump compartment can act as an antenna. While the Flow sensor and OIT cables cannot be shortened, various lengths of cable are available to minimize the "extra" cable in the truck.

When routing the cables, take care to avoid routing them next to antenna cables, radio power lines and radio components. When there is extra cable, double the cable back on itself and secure in a flat bundle with plastic wire ties instead of making a round coil.

SECTION 5. CALIBRATION AND SETUP

The Aquis system is able to be field calibrated using the control function buttons. Only units of measure, water flow and the foam percentage default can be field set.

A. Entering Calibration Mode

1. Entering calibration is accomplished by using the control unit function buttons.
2. To enter this function press and hold the SELECT button for minimum of 5 seconds. The OIT will display "5 SEC"
3. Continue to hold the SELECT button.
4. Then while the SELECT button is depressed, push the UP & DOWN arrow buttons at the same time. The display will show CAL for 2 seconds, and then display F1.
5. Use the UP Key to advance to the next parameter (F2, F3, F4).
6. Use the DOWN Key to back up to a previous parameter (F2, F1)
7. To edit a parameter, press the SELECT Key at the associated Fn Prompt.

B. F1 - Default Mix Percentage

1. At the F1 prompt, press the SELECT button.
2. Use the UP & DOWN arrow buttons to select the default FOAM %. The only foam % selections will be .1%, .2%, .3%, .4%, .5%, .6%, .7%, .8%, .9%, and 1.0%.
3. When finished, press the SELECT button to save the displayed value.

C. F2 – Units of Measurement

The units of measurement must be selected prior to any calibration functions. Units of measurement are U.S. Gallons, Imperial Gallons and Liters.

1. Push the SELECT button at the F2 Prompt. The display will show the current setting.
2. Use the UP & DOWN arrow buttons to select one of the following measurement units.

GAL will select U.S. Gallons.
IPL will select Imperial Gallons.
LTR will select Metric Liters.
3. Pushing the SELECT button will save the displayed selection.
This will allow for calibration of the water flow in the units of measurement selected.

D. F3 – Flow Rate Calibration

1. Press the SELECT button at the F3 prompt. The current measured flow rate will be displayed. Establish a flow using an accurate flow measuring device.
2. Once this is established, press the UP or DOWN buttons to advance to the calibration step. If the displayed flow rate is correct, press the SELECT button to return back to the F3 prompt.

If there is insufficient flow the display will show LoFL for 2 seconds, the return back to the F3 prompt.
3. The display will now display 50 (starting value), or the last calibration value entered.
4. Use the UP & DOWN arrow buttons to change the displayed to value match the actual flow rate according to the flow measuring device. If the button is only pressed momentarily, the display to increment or decrement by 1. If the button is held, the display will increment or decrement by 5.
5. Once the correct flow is achieved pushing the SELECT button will save the setting and return to the F3 prompt.

E. F4 –System Lockout

System can be locked out after calibration and setup to avoid accidental changing.

Warning: A locked out system can only be unlocked at a qualified Waterous Service Center

1. Press the SELECT button at the F4 prompt and “EnAb” (enabled) will be displayed.
2. Pressing the UP↑ button will toggle between “LoC” (locked) and “EnAb” (enabled). Settings will not be permanent until the calibration settings are saved.
3. Press the SELECT button and “F4” will be displayed.
4. Pressing the FOAM button, saves the settings, locks the system and can not be unlocked except at a qualified Waterous Service Center

F. F5 – Foam Select

- a) Press the SELECT button at the F5 prompt
- b) Pressing the ARROW ↑ or ↓ button will toggle between “A-A, b-b, A-b”
Running A Foam in both tanks, select A-A
Running B Foam in both tanks, select b-b
Running A Foam in one tank and B Foam in the other tank, select A-b

G. F6 – Simulated Water Flow (per NFPA testing)

- a) Press the SELECT button at the F6 prompt
- b) Pressing the Arrow **↑** or **↓** button will toggle between “0, 100, 200, 300” GPM simulated flow rate.
- c) Press SELECT.
- d) Press the FOAM button to exit Calibration mode.
- e) Displays the selected flow rate.
- f) Place a hose from the BYPASS into a bucket.
- g) Press FOAM, motor starts, foam pumps.
- h) Run for 2 or 3 minutes to equalize output.
- i) Measure the amount of concentrate in the bucket.
- j) To get out of “Simulated Water Flow”, you must get out of Calibration mode and come back to F6, setting water flow to Zero to get out of Simulated Water Flow mode.

H. Saving Calibration

To save all the calibration settings to flash memory, press the FOAM button while at the Fn (n=1-6) prompt. The data will be stored, and the unit will return to normal operation.

		Default Mix Percentage									
Flow Rate	.1%	.2%	.3%	.4%	.5%	.6%	.7%	.8%	.9%	1.0%	
100	.1	.2	.3	.4	.5	.6	.7	.8	.9	1.0	
200	.2	.4	.6	.8	1.0	1.2	1.4	1.6	1.8	2.0	
300	.3	.6	.9	1.2	1.5	1.8	2.1	2.4	2.7	3.0	
U.S. Gallons											

SECTION 6. OPERATION

A. Operating the System

Upon power up, the software revision number will be displayed. The unit will then display the flow rate.

The software will perform a linear interpolation to determine values to use for flow rates that are in between flow rates entered in the data array.

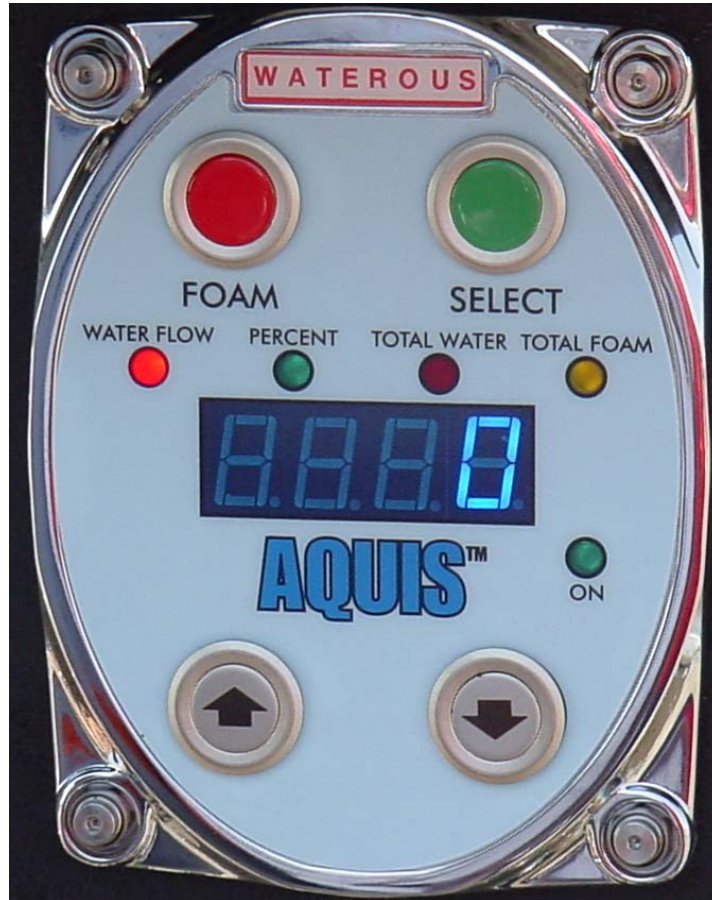

During normal operation, the OIT will display flow rate, percent mix, total water or total product.

SELECT Selects data to display. The default is to display flow rate. Pressing the SELECT button will scroll through the list, then wrap back around to the top of the list. The associated LED will light to indicate what data is being displayed.

Flow Rate
Mix Percentage
Total Water
Total Product

Holding the select button for more than 2 seconds, will lock display current position. Pressing the select button again will unlock.

UP ARROW When the Mix Percentage is displayed, the current mix setpoint will be displayed. Subsequent presses of the UP ARROW button will increase the Mix Setpoint by 0.1%. After a 10 second timeout, the display will return to the Flow Rate display.

DOWN ARROW When the Mix Percentage is displayed, the current mix setpoint will be displayed. Subsequent presses of the DOWN ARROW button will decrease the Mix Setpoint by 0.1%. After a 10 second timeout, the display will return to the Flow Rate display

Pressing both UP and DOWN simultaneously when the Total Water is displayed resets the Total Water accumulator to Zero.

Pressing both UP and DOWN simultaneously when the Total Product is displayed resets the Total Product accumulator to Zero.

Pressing both UP and DOWN simultaneously, for 2 seconds, when the Flow Rate is displayed enters the MANUAL mode of operation. See Manual Mode operation below.

Pressing both UP and DOWN simultaneously while in Mix % will go to the preset default %.

FOAM Pressing the FOAM button will alternately start and stop the foam operation. When the controller is running, the FOAM LED will be lit. The FOAM LED will blink when the motor control output is active.

Manual Mode If the display is showing the flow rate, and the two ARROW keys are pressed simultaneously, held for 2 seconds, the % MIX LED will light and the display will show a default value of 2.0.

Use the UP or DOWN arrow keys to increment or decrement this value in steps of 0.5.

Note: Pump output is based on a theoretical ratio of foam to water at 50 GPM.

While in manual mode, you can pause the motor by pressing the RED FOAM button (once). You can increase or decrease the foam percentage at this time. Resume foam flow by pressing the RED button once.

Pressing both ARROW keys again exits the MANUAL mode and stops the pump.

Note: Motor / Pump Assembly will operate in manual mode whether or not there is water flow. If the INJECT / BYPASS valve is in the INJECT position, foam concentrate will be injected into the

system, which will waste foam concentrate.

AUTO RUN

The system is equipped with an AUTO RUN feature. If the voltage (+12 or +24VDC) is applied to position 1 on the terminal strip, it will have the same effect as pressing the Red FOAM button. This will start the Foam system. The system will not inject foam until water is flowing.



**NFPA 1901 / 1906
Aquis 2.5 Foam System Certification**

Certified Manufacturer Type Test
Certified

OEM Certification Test

System

Range		Water Flow	Range	Back Press. PSI	Foam %	Foam Cap. (gpm)
Min	10	Min	0	.1	.01	
Max	325	Max	400	1	2.2	
Min	10	Max	400	.1	.01	
Max	325	Min	0	1	3.3	
Mid	160	Mid	150	.5	.8	

Flowmeter		Foam Pump Test Points					
Range	Test Points	Sim Water Flow	Set Foam %	Range	Back Press. PSI	Range	Foam (gpm)
Min				Min		Min	
Mid				Mid		Mid	
Max				Max		Max	

Range		Water Flow	Range	Back Press. PSI	Foam %	Foam Cap. (gpm)
Min	20	Min	0	.1	.02	
Max	750	Max	400	1	2.2	
Min	20	Max	400	.1	.02	
Max	750	Min	0	1	3.3	
Mid	375	Mid	150	.5	1.9	

Flowmeter		Foam Pump Test Points					
Range	Test Points	Sim Water Flow	Set Foam %	Range	Back Press. PSI	Range	Foam (gpm)
Min				Min		Min	
Mid				Mid		Mid	
Max				Max		Max	

Range		Water Flow	Range	Back Press. PSI	Foam %	Foam Cap. (gpm)
Min	30	Min	0	.1	.03	
Max	1200	Max	400	1	2.2	
Min	30	Max	400	.1	.03	
Max	1200	Min	0	1	3.3	
Mid	600	Mid	150	.5	3.0	

Flowmeter		Foam Pump Test Points					
Range	Test Points	Sim Water Flow	Set Foam %	Range	Back Press. PSI	Range	Foam (gpm)
Min				Min		Min	
Mid				Mid		Mid	
Max				Max		Max	

Installer Certification
Installed, Calibrated and Tested to Waterous AZ's Installation Recommendations and Purchaser's Performance Specifications

Tester: _____

Date: _____

Form: 482.1121

Issued: 7/21/10

This page has been left intentionally blank.

SECTION 7. TROUBLESHOOTING CHART

Aquis 2.5 Trouble shooting Chart		
Symptom	Probable Cause(s)	Corrective Action
1. Pump runs but produces no flow	Pump is not primed.	See Aquis 2.5 instructions page 21 for priming instructions
	No foam in tank	Fill foam tank
	Foam tank valve closed	Open valve
	Strainer plugged	Remove and clean strainer
	Check valves stuck in pump	Remove and clean check valves
2. Pump loses prime	Air leak in suction hose or inlet fittings.	Remove suction hose and test for leaks by pressurizing hose with water. Make sure thread sealant has been used on all fittings.
	Suction line is blocked, collapsed or too small.	Remove suction line and inspect it for debris lodged in hose. Replace line with larger if it is too small. Avoid all unnecessary bends. Do not kink hose.
3. Proportioner uses excessive amounts of concentrate (runs rich)	Speed sensor position incorrect.	Reset speed sensor position by referring to manual for instructions.
	Paddle wheel out of calibration.	Calibrate paddle wheel flow per instructions in manual.
	System is in manual mode.	Depress up and down arrows simultaneously.
	Foam pump out of calibration.	Contact Waterous for reprogramming.
4. Proportioner uses too little of concentrate (runs lean)	Paddle wheel out of calibration.	Calibrate paddle wheel flow per instructions in manual.
	Foam pump out of calibration.	Contact Waterous for reprogramming.
5. Pump runs full speed whenever the proportioner is either on or off	Faulty driver box.	Replace driver box.
6. Pump runs full speed whenever the proportioner is on	Poor ground to motor driver box on pump/motor	Make sure screws are tight and a good ground
7. OIT green light fails to illuminate when on button is depressed	Cables not correctly connected.	Inspect and secure connections.
	Inadequate ground.	Inspect and secure connections.
	Inadequate voltage.	Check voltage at system connection.
8. Proportioner will not inject concentrate.	Power not on.	Turn power on.
	Relief valve is set too low. (factory preset at 450 psi)	Reset relief to factory setting.
	Inject/Bypass valve in bypass position.	Move to inject position.
9. System is powered up and the Foam ON/OFF switch has been pressed but the foam pump doesn't run.	Control cable(s) defective.	Replace control cable(s)
	No water is flowing in any of the foam discharges.	Flow water through a foam capable discharge.
	Poor paddle wheel connection.	Check and reconnect.
	Paddle wheel obstructed.	Clear paddle wheel of debris.
	Paddle wheel not functioning.	Replace paddle wheel.
10. Delay in foam showing at nozzle	Low foam percentage and or low water flow.	Increase as needed.
	Proportioner not primed.	Prime proportioner per instructions.
	Foam inject check valve stuck open.	Replace foam inject check valve.
11. Poor foam quality during low water flows	Foam percentage is too low.	Increase foam percentage.
	Foam strainer restricted.	Remove and clean foam strainer.
	Foam system calibration incorrect.	Re-calibrate.
12. N Con is displayed on OIT indicating no concentrate	Foam tank empty.	Fill foam tank.
	Float stuck on plunger—indicating tank is low.	Inspect and clean float switch.
	Low level sensor or wiring is inoperative.	Repair or replace defective components.
	Float installed incorrectly.	Reinstall float per instruction manual.
13. OIT fails to light up	Check master power on vehicle.	Turn on master power.
	Breaker switch has been tripped.	Reset breaker.
14. Green OIT light fails to flash while flowing water through foam manifold	Inoperative paddle wheel	Test by removing paddle wheel and spinning by hand. Replace paddle wheel if light still fails to flash.
	Poor paddle wheel cable connections.	Check connections.
	Speed sensor position incorrect.	Reset speed sensor position by referring to manual for instructions.
15. OIT shows bars in the digital display area	Communication error.	Check connections on OIT and control box.
16. Foam in the water tank	Foam was poured in the wrong tank.	Flush water tank.
	Injection check valve stuck open.	Replace injection check valve.
	Foam manifold check valve fails to seal.	Inspect and clean or replace as necessary.
	Foam manifold drain is plumbed to master drain.	Isolate foam manifold drain.
17. Inaccurate flow reading	Wrong units selected.	Select correct units in F2 prompt in calibration mode.

	(GAL, IPL, LTR)	
	Improper calibration.	Check and re-calibrate.

SECTION 8. DRAWINGS

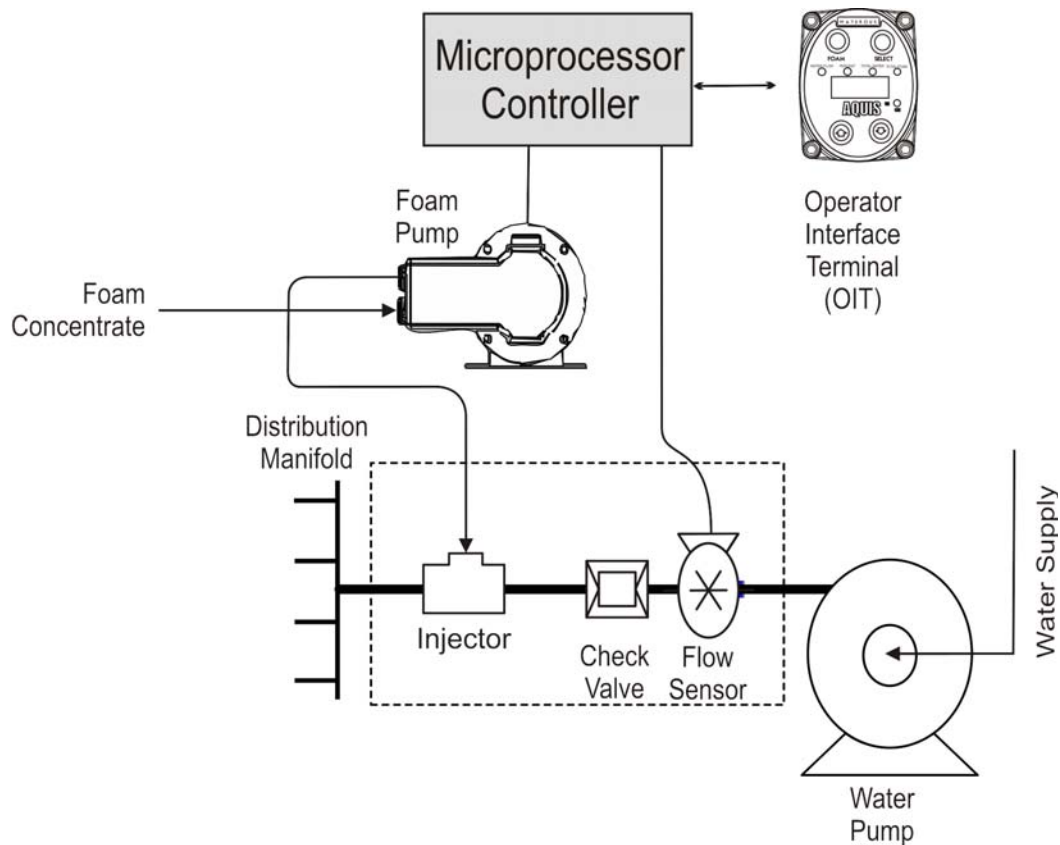

Figure 7 Basic System Schematic

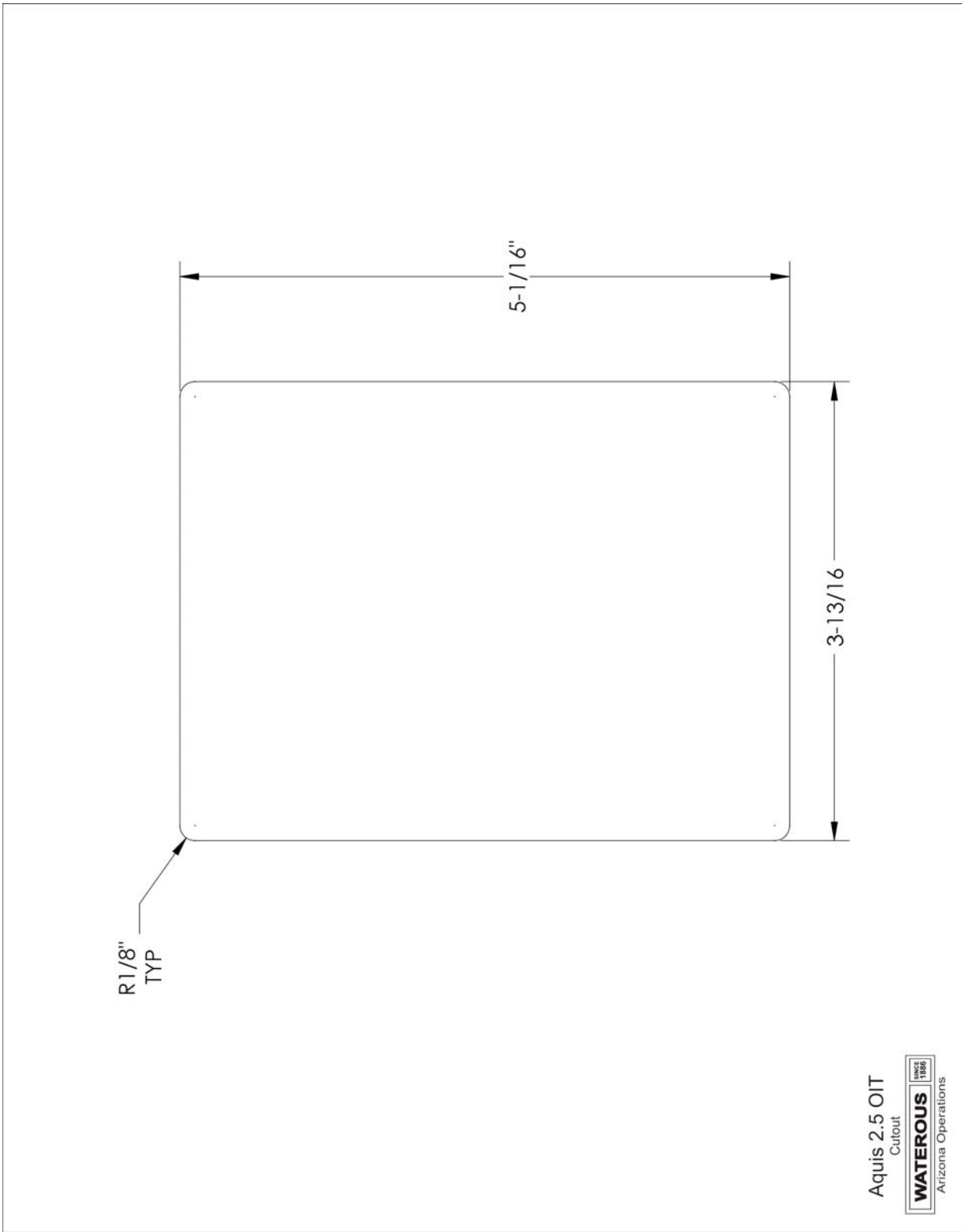
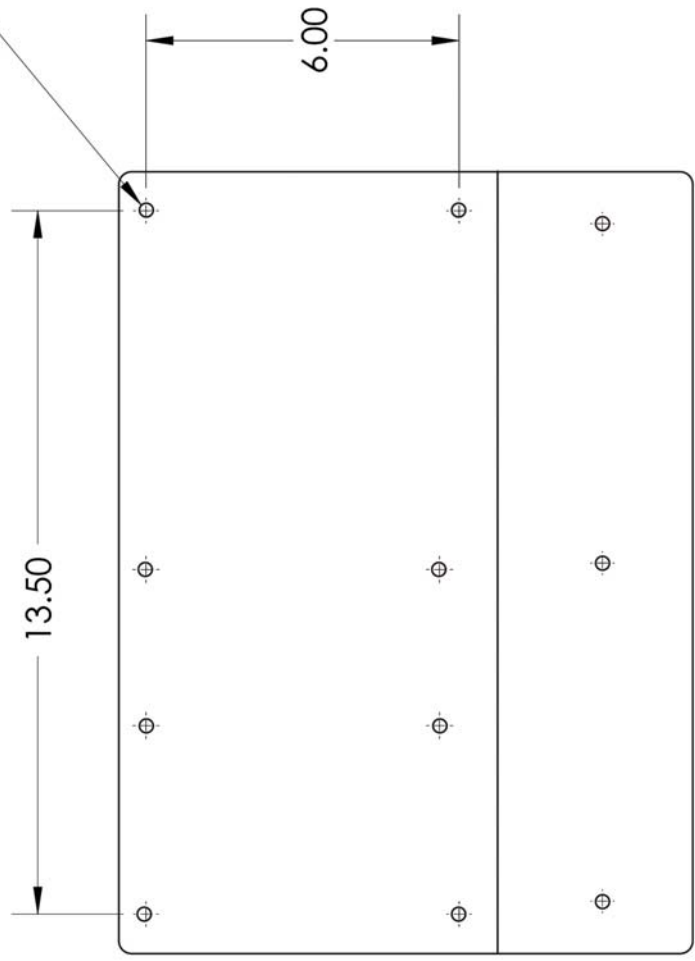

Figure 8 OIT (Display) Panel Cutout

Ø .281
TYP



Aquis
Z Bracket Mounting Holes
WATEROUS
Arizona Operations

Drawing is NOT to scale

Figure 9 Aquis Z Bracket Mount Bolt Pattern

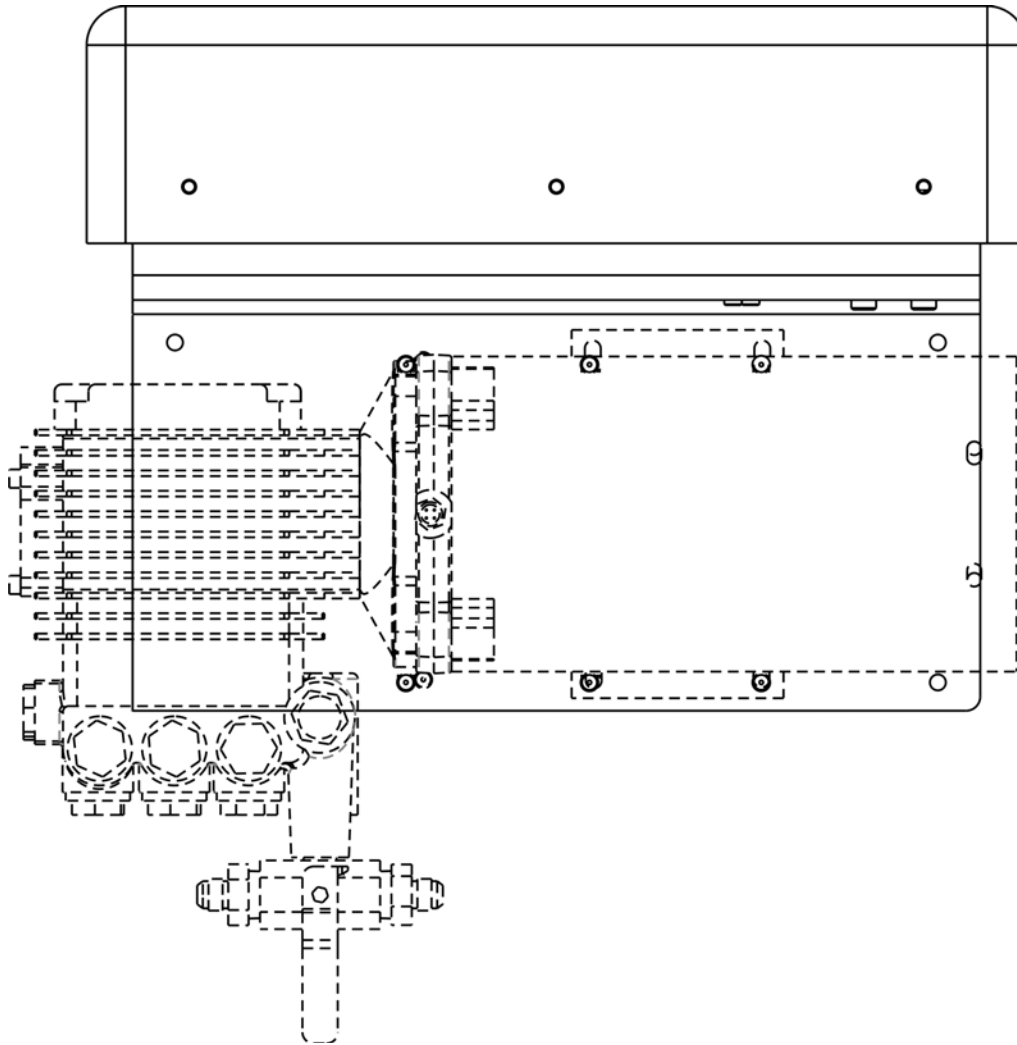

Figure 10 Motor – Pump orientation NORMAL

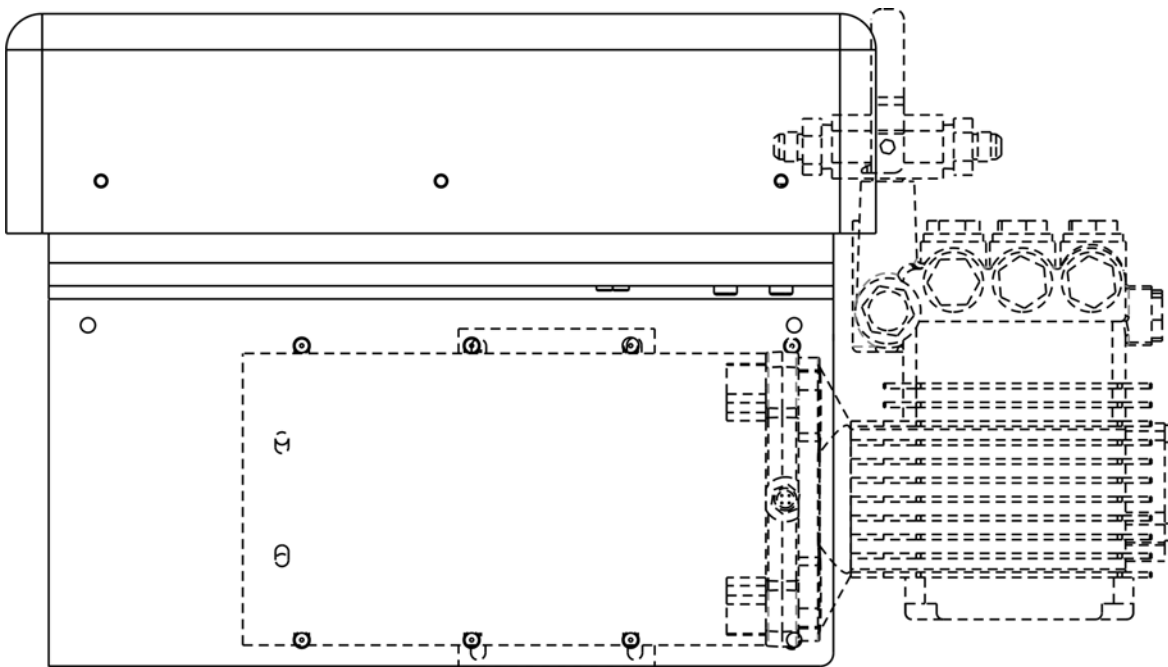
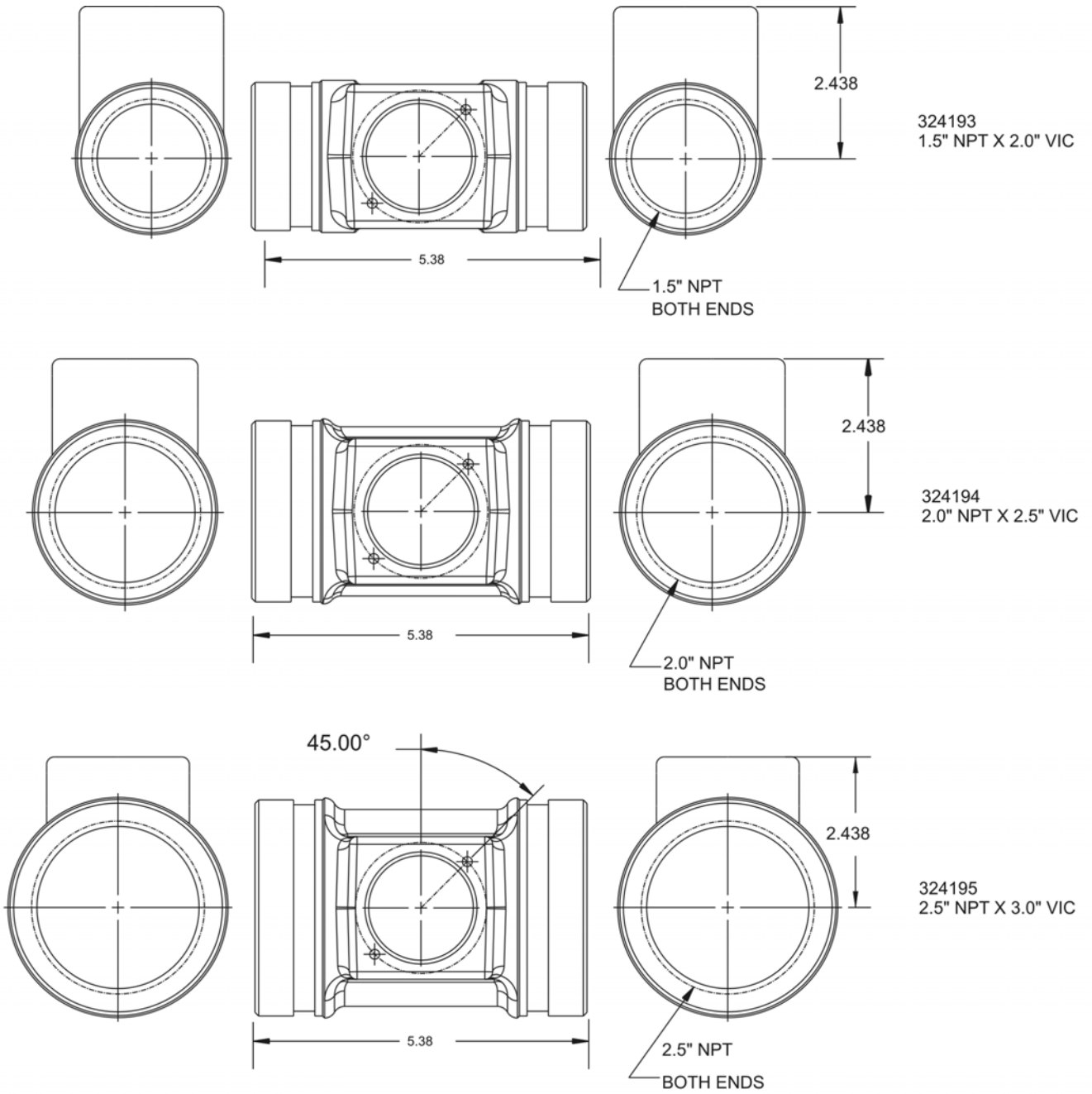

Figure 11 Motor – Pump orientation REVERSED



FLOW TEE - CAST BRASS

NOTES:
DIMENSIONS ARE APPROXIMATE
DESIGN AND SPECIFICATIONS SUBJECT TO CHANGE WITHOUT NOTICE

Figure 12 Aquis Flow Tees

SECTION 9. PART LIST

Part #	Description	Details	Qty
/9850003	MANUAL SET		1
0311193	Z BRACKET AQUIS 1.5 & 2.5		1
0315289	SPACER – PUMP ADVANTUS & AQUIS		1
0315305	AQUIS VACUUM FORMED COVER		1
0315306	AQUIS MOTOR DRIVER ENCL- BASE		1
0315307	AQUIS MOTOR DRIVER ENCL.-COVER		1
0315311	AQUIS PRODUCT SENSOR		1
0315315	AQUIS SCHEMATIC PLATE		1
0315322	AQUIS INSTRUCTION PLATE		1
0324175	AQUIS 1.5 NPT -2.0 VIC FLOW TEE		1
2410055	3/8" BRASS CHECK VALVE		1
2450003	3/4" WYE STRAINER		1
4010016	DC60 MOTOR CONTROL (MOTOR DRIV		1
4190014	ADVANTUS PRODUCT SENSOR-TURCK		1
4190017	AQUIS PADDLE WHEEL FLOWMETER/T		1
4250009	TERMINAL CONNECTOR 5 PT5-140		1
4250010	CONNECTOR MARKER STRIP MS-5-14		1
4270000	MOTOR – WASHGUARD 1/2 HP	12VDC	1
4270003		24VDC	
4290014	AQUIS 2.5 OIT ASSY		1
4290016	AQUIS 1.5 & 2.5 CONTROL BOARD		1
4310016	CABLE - AQUIS1.5 & 2.5 OIT		1
4310017	CABLE – FLOWMETER AQUIS1.5 & 2.5		1
4310018	CABLE – PRODUCT SENSOR AQUIS		1
5010042	PUMP – COMET LWS3020 E-K W/BU		1
8070100	80 AMP RESET CIRCUIT BREAKER	12VDC	1
8070002	50 AMP RESET CIRCUIT BREAKER	24VDC	

SECTION 10. WATEROUS 1-YEAR LIMITED WARRANTY POLICY

WATEROUS warrants, to the original Buyer only, that products manufactured by WATEROUS will be free from defects in material and workmanship under normal use and service for a period of one (1) year from the date the product is first placed in service, or one and one-half (1-1/2) years from the date of shipment by WATEROUS, whichever period shall be the first to expire; provided the Buyer notifies WATEROUS, in writing, of the defect in said product within the warranty period, and said product is found by WATEROUS to be nonconforming with the aforesaid warranty. When required in writing by WATEROUS, defective products must be promptly returned by Buyer to WATEROUS at WATEROUS' plant at South St. Paul, Minnesota, or at such other place as may be specified by WATEROUS, with transportation and other charges prepaid. A Returned Material Authorization (RMA) is required for all products and parts and may be requested by phone, fax, email, or mail. The aforesaid warranty excludes any responsibility or liability of WATEROUS for:

- (a) damages or defects due to accident, abuse, misuse, abnormal operating conditions, negligence, accidental causes, use in non-firefighting applications, or improper maintenance, or attributable to written specifications or instructions furnished by Buyer;
- (b) defects in products manufactured by others and furnished by WATEROUS hereunder, it being understood and agreed by the parties that the only warranty provided for such products shall be the warranty provided by the manufacturer thereof which, if assignable, WATEROUS will assign to Buyer, if requested by Buyer;
- (c) any product or part, altered, modified, serviced or repaired other than by WATEROUS, without its prior written consent;
- (d) the cost of dismantling, removing, transporting, storing, or insuring the defective product or part and the cost of reinstallation; and
- (e) normal wear items (packing, strainers, filters, light bulbs, anodes, intake screens, mechanical seals, etc.).

ALL OTHER WARRANTIES ARE EXCLUDED, WHETHER EXPRESS OR IMPLIED BY OPERATION OF LAW OR OTHERWISE, INCLUDING ALL IMPLIED WARRANTIES OF MERCHANTABILITY OR FITNESS FOR A PARTICULAR PURPOSE. IN NO EVENT, WHETHER AS A RESULT OF BREACH OF CONTRACT, WARRANTY, TORT (INCLUDING NEGLIGENCE), STRICT LIABILITY, OR ANY OTHER CAUSE OF ACTION, SHALL WATEROUS BE LIABLE FOR ANY PUNITIVE, SPECIAL, INCIDENTAL OR CONSEQUENTIAL DAMAGES, OR FOR PERSONAL INJURY OR PROPERTY DAMAGES.

The exclusive remedy of Buyer and the sole liability of WATEROUS, whether based on contract, warranty, tort or any other basis of recovery whatsoever, is expressly limited at the election of WATEROUS to:

- (a) the replacement at the agreed point of delivery of any product or part, which upon inspection by WATEROUS or its duly authorized representative, is found not to conform to the limited warranty set forth above, or
- (b) the repair of such product or part, or
- (c) the refund or crediting to Buyer of the net sales price of the defective product or part.

BUYER'S REMEDIES CONTAINED HEREIN ARE EXCLUSIVE OF ANY OTHER REMEDY OTHERWISE AVAILABLE TO BUYER.

Waterous Company
125 Hardman Avenue South
South St. Paul, MN 55075 USA
www.waterousco.com

