

## Technical Bulletin No. 133

## K & T Series Transmission Update

Beginning on orders received February 1, 2020, the updated aluminum-case, K & T Series Transmissions will replace the iron-case K & T Series Transmissions. See product improvements and dimensional changes listed below. **NOTE: All internal components of the updated aluminum-cased K & T Series Transmissions are compatible with the iron-cased K & T Series Transmissions.**

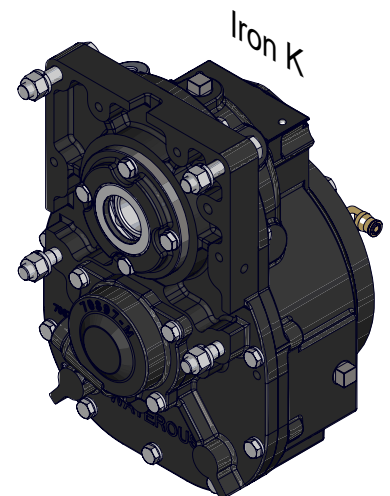
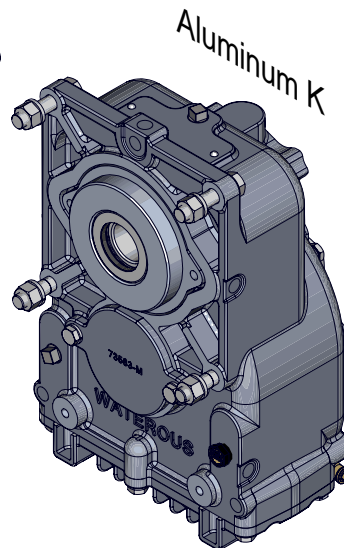
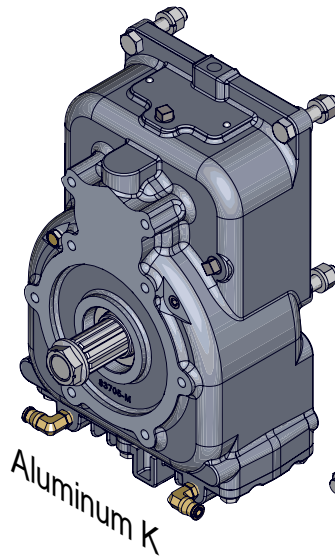
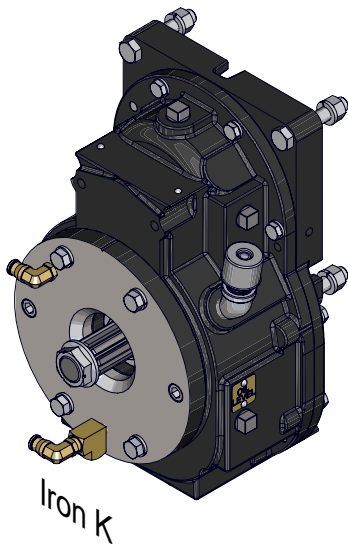

### Improvements Over Previous Model

- Case material changed from iron to aluminum
- Overall weight reduced by 50% (47 lb, 21 kg)
- One-piece case with oil pan
- Lube capacity increased for inverted models

### Additional Improvements

- Oil cooling compatibility is now available with T Series Transmission configuration
- Consistent lubrication in every orientation
- O-ring seal between case and oil pan

## New Aluminum K Series Transmission Dimensions

---

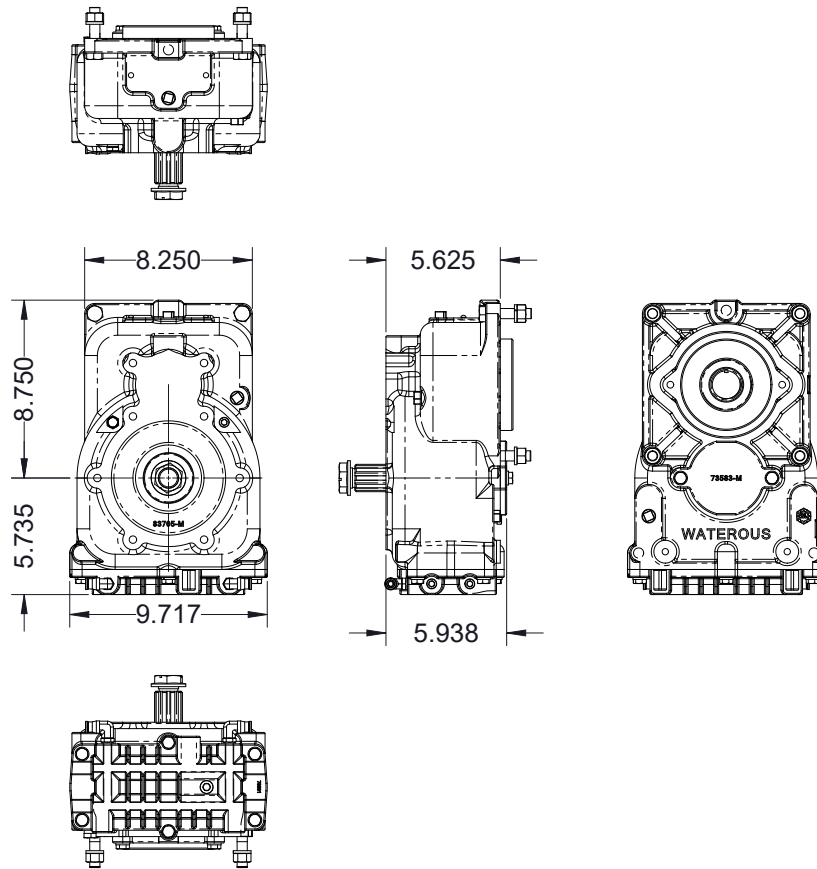

## Current Iron K Series Transmission Dimensions

---

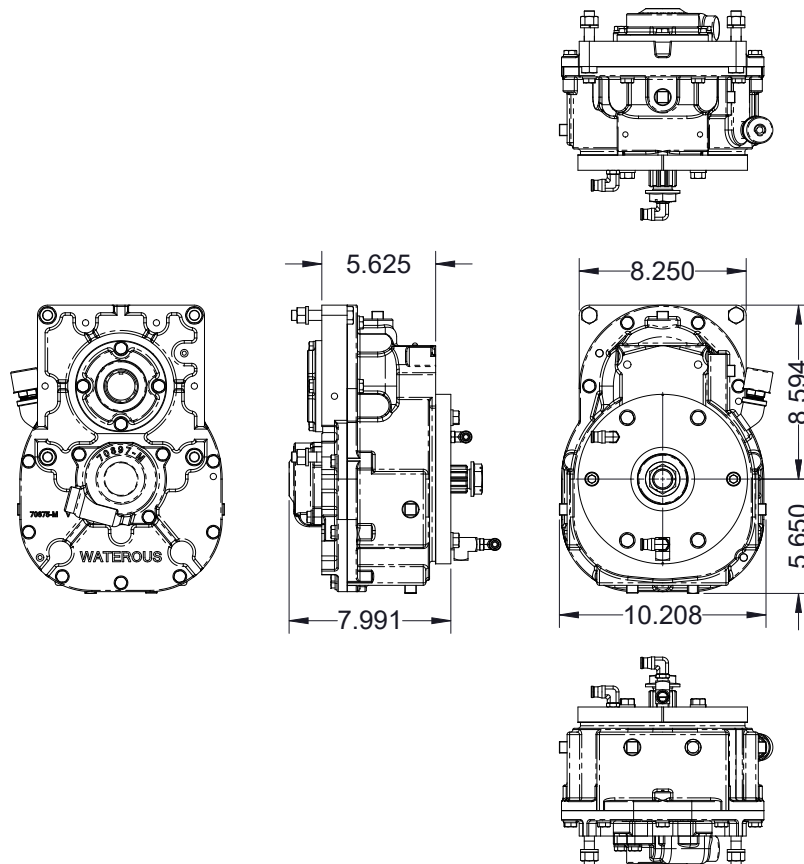

# Medium Duty K Series Transmission

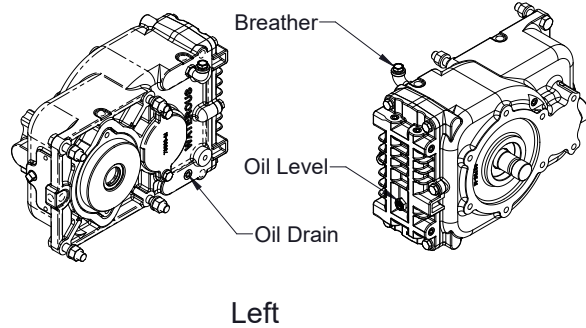
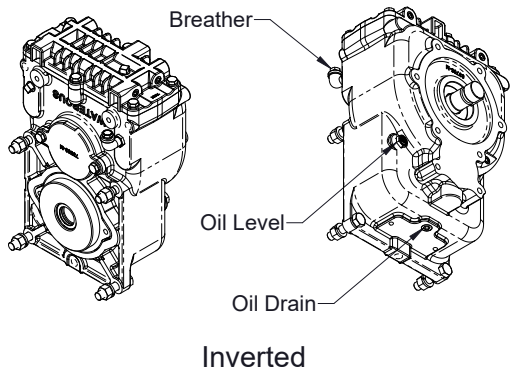
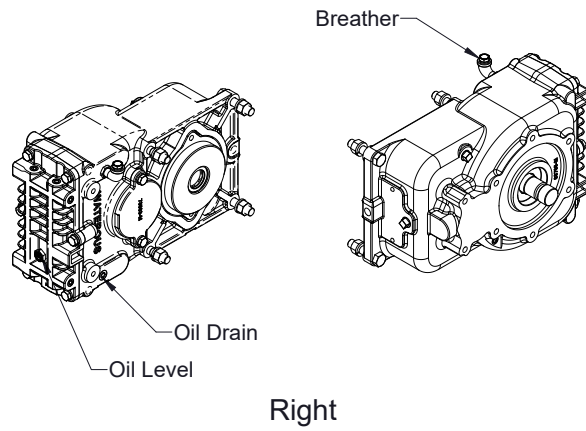
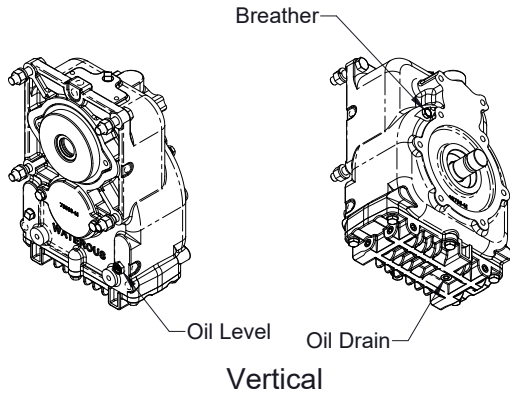

# Heavy Duty K Series Transmission

