

SIREN

E-NEWSLETTER

January, 2013

Waterous Introduces the E500 with Kubota Engine

The Waterous E500 Series Motor Pump is specifically designed for mounting on specialized attack vehicles. The diesel-powered 24.8 hp (18.5 kw) Kubota engine, Model D902-E3B mated to a Waterous high-strength aluminum alloy centrifugal fire pump produces up to 400 PSI (28 bar) of pressure or up to 275 GPM (1140 l/m) of flow.

The Kubota engine replaces the Briggs & Stratton (Diahatsu) Engine that no longer met emission regulations in the United States. Waterous engineers determined that the 24.8 hp Kubota engine was a proper fit. Performance met or exceeded the previous E500 Models.

Other key features of the E500:

New Control Module - Allows the operator to change operating parameters electronically with a touch of a button.

The new Kubota engine meets Tier 4 Emission Regulations.

To learn more about the E500 Motor Pump, [click here](#).



New Control Module

Markets - Waterous is More Than Fire Suppression

For the last 126 years, Waterous has been the leader in Fire Suppression products; however, did you know that we also has been building products for other industries and markets?

For several decades, Waterous has been supplying the Decoking/Descaling industry with the CMU pump. This pump is the only water pump that holds up to the rigors of pigging, a process where a plug-type device with protusions (pig) is forced through the pipes of oil refinery furnances with water pressure produced by the CMU pump. As the pig scours the pipes, it makes a squealing sound and thus the name.

Waterous also supplies products for de-icing of aircraft and



De-icing Aircraft

refueling aircraft, power washing of insulators on high-voltage power lines, nuclear cooling / standby cooling and transmissions for vehicles on high-rails.

Waterous is more than just a fire suppression company, we are a solutions company. Don't hesitate to contact us with your application. We might just have the solution.



High-Rail Application

In Case of Fire, Push Button

The benefits of compressed air foam are well known. Improved firefighter safety, faster knockdown time, less water used and less property damage. With that knowledge, why aren't more departments using CAFS today? The common theme is that CAFS is too difficult to operate. Waterous has taken the difficulty out of CAFS by developing the ONE STEP™ CAFSystem.

The ONE STEP™ takes all of the operations that go into creating CAFS out of the equation. All settings are preset at the factory, automatic inlet pressure reduced to 120 psi eliminating the worry of high inlet hydrant pressure, the revolutionary foam generators provide a reproducible, consistent foam structure every time and best of all, press a button to engage the system.

Other Strategic Advantages of the ONE STEP™ CAFSystem:

- Lighter hose weights – less water allows for easy hose maneuverability, creating less fatigue to the firefighter.
- Less steam created due to the reduced amount of water used and a greater consistency of the foam.
- Hose lengths do not matter. From 100 feet to 1000 feet, the foam available at the discharge is the same, consistent structure every time.

The ONE STEP™ System incorporates a powerful integrated air compressor system, an Advantus Foam Proportioner and compact foam generators mounted on a Waterous CS, CSU or CMU fire pump. The ONE STEP™ is also available on Slide-in Modular CAFS such as the new 100-50-OS and soon to be offered on Waterous PTO systems.

For more information on the ONE STEP™ CAFS, [click here](#).

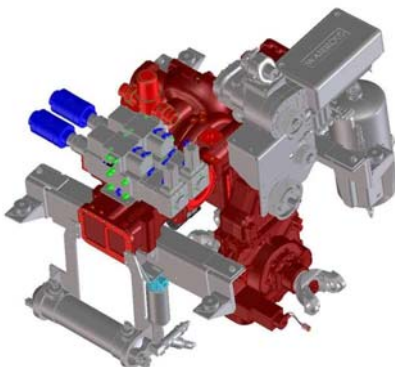

ONE STEP™ Mounted On a Waterous CSU Fire Pump

Waterous President and CEO Receives Excellence Award

On December 6, 2012, Bill Smith, President and CEO of Waterous was honored by the River Heights Chamber of Commerce and presented the Forrest Glewwe Visions of Excellence Award which is given out to extraordinary business leaders in the River Heights Chamber of Commerce business community.

Bill excelled in all of the criteria the award encompasses, including applying himself completely to the principles of entrepreneurship, family, ethics and corporate citizenship.

"I would like to express my sincere thanks to everyone who felt me worthy of receiving such a prestigious award. I will do everything in my power to live up to the established standards set for this award," noted Bill.

The River Heights Chamber of Commerce is a group made up of 260 businesses that provides sales tool for its members and the community, unceasingly promoting their business, products and services, watchdog protecting business interests, particularly in the political arena, united voice that often proves effective and beneficial to businesses where a single voice goes unheard.

"The River Heights Chamber of Commerce and local business community commemorates this special occasion by honoring Bill Smith, a man who has earned the respect of the River Heights Community for his hard work, local support and his belief in the spirit of free enterprise."



Waterous History

Service Tips - Extend the Life of Your Pump

Appropriate personnel should read the fire pump owners manual, then establish a written maintenance and training program. After you have established your guidelines, the next step is to follow your program.

Operate your fire pump and accessories weekly/monthly to confirm all components are functioning properly. If you encounter problems, document each situation and schedule needed repair(s). Remember, the best preventive maintenance is to regularly exercise and operate your pumping system(s). [Click here to read the article.](#)



Illustrated above is one of twenty WATEROUS Equipped Ward LaFrance Pumps now being delivered to New York City Fire Department.



New York's first motor-driven pumper, in 1909, shown above, was a WATEROUS—the engine, transmission, etc., as well as the Pump were WATEROUS, and now thirty-seven years later the WATEROUS Pumps going into the New York City Fire Department are built according to the same high standards.

You, too, can have WATEROUS dependability by specifying WATEROUS on your new piece of pumping equipment. WATEROUS Pumps are the standard of nationally recognized fire apparatus.

WATEROUS COMPANY • ST. PAUL, MINNESOTA

WATEROUS FIRE PUMPS

1946 Waterous Advertisement

Just like in 1946, Waterous still protects New York City as well as other cities across the United States and Canada including Boston, Philadelphia, Dallas, Denver, Las Vegas, Los Angeles, Honolulu, Anchorage, Vancouver, Minneapolis/St. Paul and many more. Trust Waterous to protect your city.